

FEATURES

- **Very Low Noise: 1mV_{P-P} Output Ripple**
- **-5V at 150mA from a 5V Input**
- **Better Regulation Than a Charge Pump**
- Effective Output Impedance: 0.14Ω
- Uses Tiny Capacitors and Inductors
- Internally Compensated
- Fixed Frequency 1.4MHz Operation
- Low Shutdown Current: <1μA
- Low V_{CESAT} Switch: 300mV at 300mA
- Tiny 5-Lead SOT-23 Package

APPLICATIONS

- MR Head Bias
- Digital Camera CCD Bias
- LCD Bias
- GaAs FET Bias
- Positive-to-Negative Conversion

DESCRIPTION

The LT[®]1611 is the industry's first inverting 5-lead SOT-23 current mode DC/DC converter. Intended for use in small, low power applications, it operates from an input voltage as low as 1.1V and switches at 1.4MHz, allowing the use of tiny, low cost capacitors and inductors 2mm or less in height. Its small size and high switching frequency enable the complete DC/DC converter function to consume less than 0.25 square inches of PC board area. Capable of generating -5V at 150mA from a 5V supply or -5V at 100mA from a 3V supply, the LT1611 replaces nonregulated "charge pump" solutions in many applications.

The LT1611 operates in a dual inductor inverting topology which filters the input side as well as the output side of the DC/DC converter. Fixed frequency switching ensures a clean output free from low frequency noise typically present with charge pump solutions. No load quiescent current of the LT1611 is 3mA, while in shutdown quiescent current drops to 0.5μA. The 36V switch allows V_{IN} to V_{OUT} differential of up to 33V.

The LT1611 is available in the 5-lead SOT-23 package.

 LTC and LT are registered trademarks of Linear Technology Corporation.

TYPICAL APPLICATION

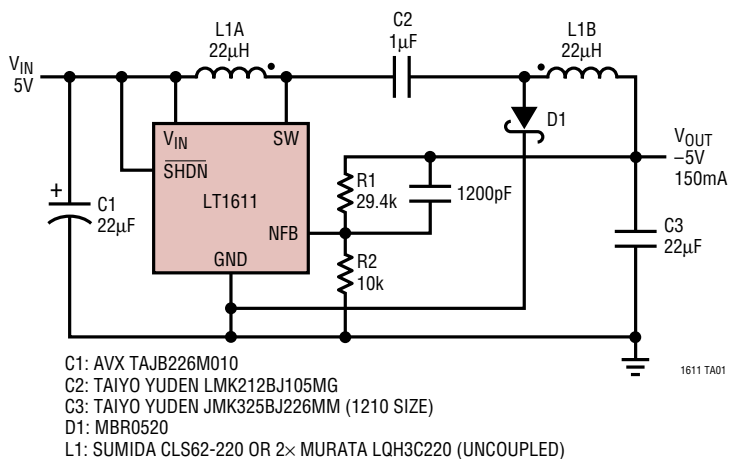

Transient Response

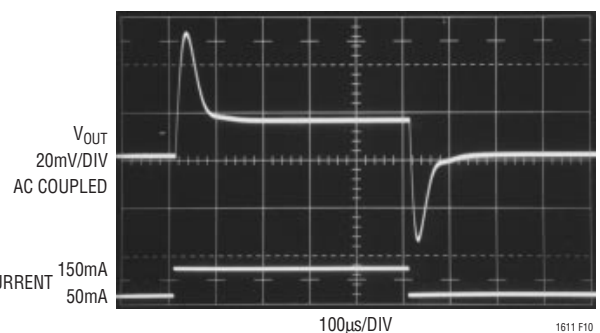

Figure 1. 5V to -5V, 150mA Low Noise Inverting DC/DC Converter

ABSOLUTE MAXIMUM RATINGS

(Note 1)

V_{IN} Voltage	10V
SW Voltage	-0.4V to 36V
NFB Voltage	-3V
Current into NFB Pin	± 1 mA
\overline{SHDN} Voltage	10V
Maximum Junction Temperature	125°C
Operating Temperature Range	
Commercial	0°C to 70°C
Extended Commercial (Note 2)	-40°C to 85°C
Storage Temperature Range	-65°C to 150°C
Lead Temperature (Soldering, 10 sec)	300°C

PACKAGE/ORDER INFORMATION

	ORDER PART NUMBER
	LT1611CS5
	S5 PART MARKING
	LTES

Consult factory for Industrial and Military grade parts.

ELECTRICAL CHARACTERISTICS The ● denotes the specifications which apply over the full operating temperature range, otherwise specifications are at $T_A = 25^\circ\text{C}$. $V_{IN} = 1.5\text{V}$, $V_{\overline{SHDN}} = V_{IN}$ unless otherwise noted.

PARAMETER	CONDITIONS	MIN	TYP	MAX	UNITS
Minimum Operating Voltage			0.9	1.1	V
Maximum Operating Voltage				10	V
NFB Pin Bias Current	$V_{NFB} = -1.23\text{V}$	● -2.7	-4.7	-6.7	μA
Feedback Voltage		● -1.205	-1.23	-1.255	V
Quiescent Current	$V_{\overline{SHDN}} = 1.5\text{V}$, Not Switching		3	4.5	mA
Quiescent Current in Shutdown	$V_{\overline{SHDN}} = 0\text{V}$, $V_{IN} = 2\text{V}$		0.01	0.5	μA
	$V_{\overline{SHDN}} = 0\text{V}$, $V_{IN} = 5\text{V}$		0.01	1.0	μA
Reference Line Regulation	$1.5\text{V} \leq V_{IN} \leq 10\text{V}$		0.02	0.2	%/V
Switching Frequency		● 1.0	1.4	1.8	MHz
Maximum Duty Cycle		● 82	86		%
Switch Current Limit	(Note 3)	550	800		mA
Switch V_{CESAT}	$I_{SW} = 300\text{mA}$		300	350	mV
Switch Leakage Current	$V_{SW} = 5\text{V}$		0.01	1	μA
\overline{SHDN} Input Voltage High		1			V
\overline{SHDN} Input Voltage Low				0.3	V
\overline{SHDN} Pin Bias Current	$V_{\overline{SHDN}} = 3\text{V}$		25	50	μA
	$V_{\overline{SHDN}} = 0\text{V}$		0	0.1	μA

Note 1: Absolute Maximum Ratings are those values beyond which the life of a device may be impaired.

Note 2: C grade device specifications are guaranteed over the 0°C to 70°C temperature range. In addition, C grade device specifications are assured over the -40°C to 85°C temperature range by design or correlation, but are not production tested.

Note 3: Current limit guaranteed by design and/or correlation to static test. Slope compensation reduces current limit at higher duty cycle.

TYPICAL PERFORMANCE CHARACTERISTICS

Efficiency, $V_{OUT} = -5V$

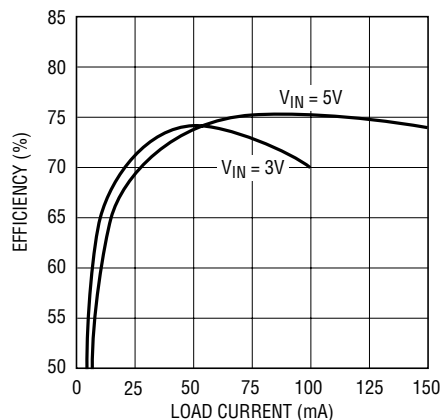

1611 G01

V_{NFB} vs Temperature

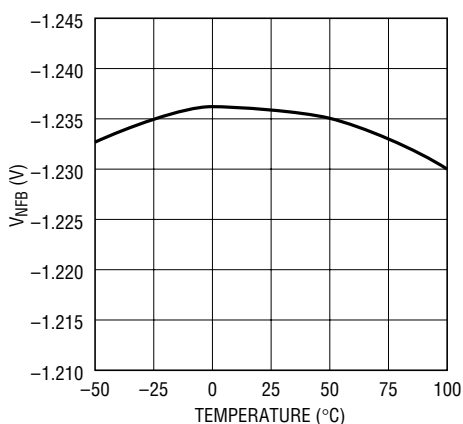

1611 G02

NFB Pin Bias Current vs Temperature

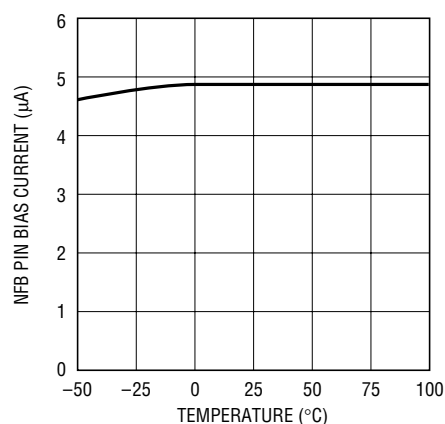

1611 G03

Switch V_{CESAT} vs Switch Current

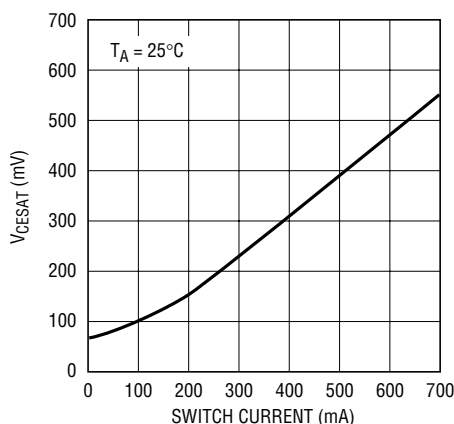

1611 G04

SHDN Pin Bias Current vs V_{SHDN}

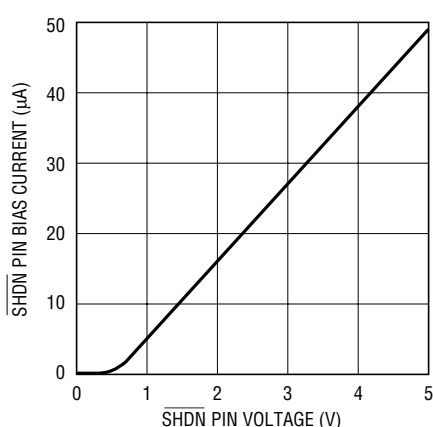

1611 G05

Switch Current Limit vs Duty Cycle

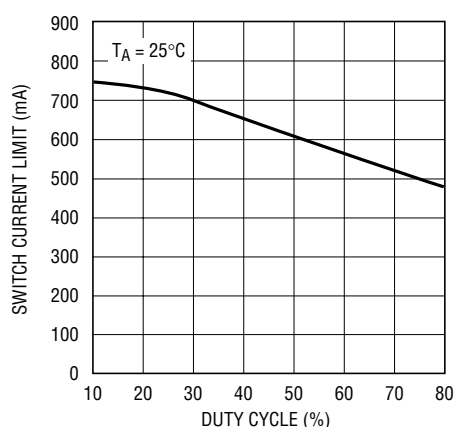

1611 G06

Oscillator Frequency vs Temperature

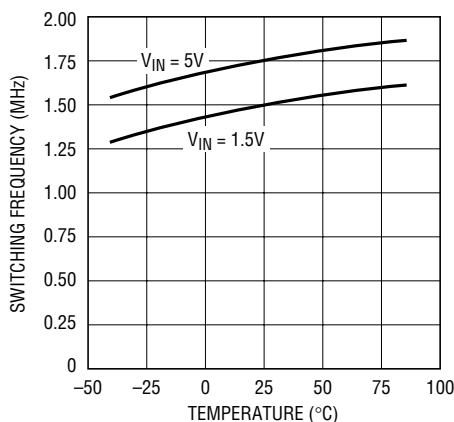

1611 G07

No-Load Operating Quiescent Current vs Temperature*

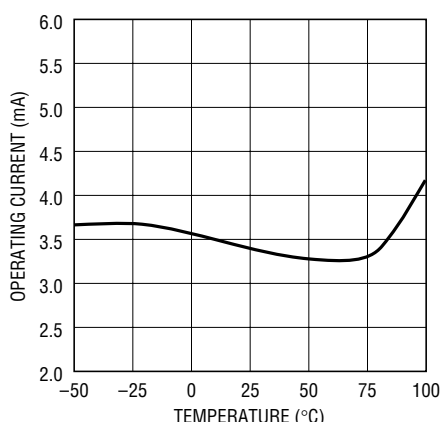

1611 G08

Switch Current Limit vs Temperature (Duty Cycle = 30%)

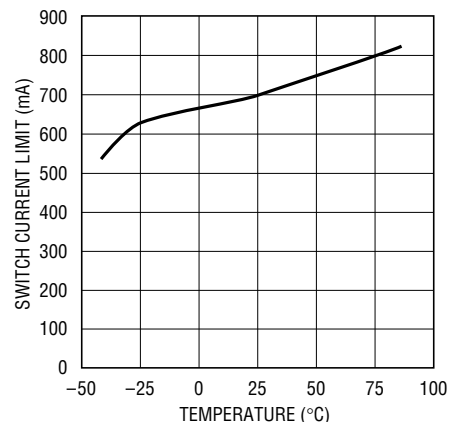

1611 G09

* Includes bias current through R1, R2 and Schottky leakage current at $T \geq 75^\circ\text{C}$

PIN FUNCTIONS

SW (Pin 1): Switch Pin. Minimize trace area at this pin to keep EMI down.

GND (Pin 2): Ground. Tie directly to local ground plane.

NFB (Pin 3): Negative Feedback Pin. Minimize trace area. Reference voltage is -1.23V . Connect resistive divider tap here. The suggested value for R2 is 10k. Set R1 and R2 according to:

$$R1 = \frac{|V_{OUT}| - 1.23}{\frac{1.23}{R2} + (4.5 \cdot 10^{-6})}$$

SHDN (Pin 4): Shutdown Pin. Tie to 1V or more to enable device. Ground to shut the device down.

V_{IN} (Pin 5): Input Supply Pin. Must be locally bypassed.

BLOCK DIAGRAM

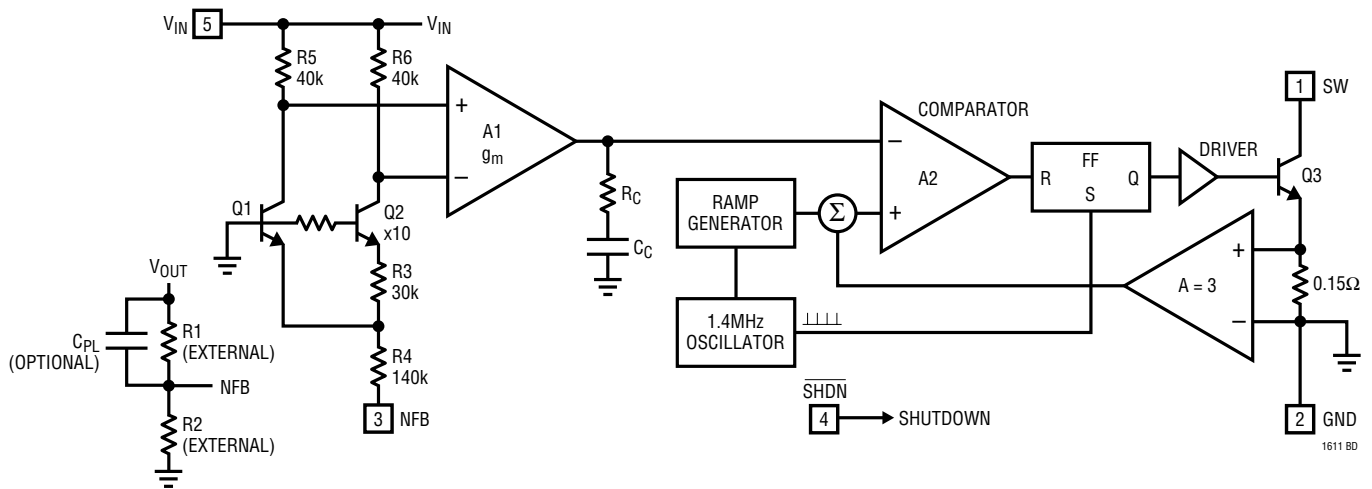

Figure 2

OPERATION

The LT1611 combines a current mode, fixed frequency PWM architecture with a -1.23V reference to directly regulate negative outputs. Operation can be best understood by referring to the block diagram of Figure 2. Q1 and Q2 form a bandgap reference core whose loop is closed around the output of the converter. The driven reference point is the lower end of resistor R4, which normally sits at a voltage of -1.23V . As the load current changes, the NFB pin voltage also changes slightly, driving the output of g_m amplifier A1. Switch current is regulated directly on a cycle-to-cycle basis by A1's output. The flip-flop is set at the beginning of each cycle, turning on the switch. When the summation of a signal representing switch current and a ramp generator (introduced to avoid subharmonic oscillations at duty factors greater than 50%) exceeds the V_C signal, comparator A2 changes stage, resetting the flip-

flop and turning off the switch. Output voltage decreases (the magnitude increases) as switch current is increased. The output, attenuated by external resistor divider R1 and R2, appears at the NFB pin, closing the overall loop. Frequency compensation is provided internally by R_C and C_C . Transient response can be optimized by the addition of a phase lead capacitor, C_{PL} , in parallel with R1 in applications where large value or low ESR output capacitors are used.

As load current is decreased, the switch turns on for a shorter period each cycle. If the load current is further decreased, the converter will skip cycles to maintain output voltage regulation.

The LT1611 can work in either of two topologies. The simpler topology appends a capacitive level shift to a

OPERATION

boost converter, generating a negative output voltage, which is directly regulated. The circuit schematic is detailed in Figure 3. Only one inductor is required, and the two diodes can be in a single SOT-23 package. Output noise is the same as in a boost converter, because current is delivered to the output only during the time when the LT1611's internal switch is off.

If D2 is replaced by an inductor, as shown in Figure 4, a higher performance solution results. This converter topology was developed by Professor S. Cuk of the California Institute of Technology in the 1970s. A low ripple voltage results with this topology due to inductor L2 in series with the output. Abrupt changes in output capacitor current are eliminated because the output inductor delivers current to the output during both the off-time and the on-time of the LT1611 switch. With proper layout and high quality output capacitors, output ripple can be as low as 1mV_{P-P}.

The operation of Cuk's topology is shown in Figures 5 and 6. During the first switching phase, the LT1611's switch, represented by Q1, is on. There are two current loops in operation. The first loop begins at input capacitor C1, flows through L1, Q1 and back to C1. The second loop flows from output capacitor C3, through L2, C2, Q1 and back to C3. The output current from R_{LOAD} is supplied by L2 and C3. The voltage at node SW is V_{GESAT} and at node SWX the voltage is $-(V_{IN} + |V_{OUT}|)$. Q1 must conduct both L1 and L2 current. C2 functions as a voltage level shifter, with an approximately constant voltage of $(V_{IN} + |V_{OUT}|)$ across it.

When Q1 turns off during the second phase of switching, the SW node voltage abruptly increases to $(V_{IN} + |V_{OUT}|)$. The SWX node voltage increases to V_D (about 350mV). Now current in the first loop, beginning at C1, flows through L1, C2, D1 and back to C1. Current in the second loop flows from C3 through L2, D1 and back to C3. Load current continues to be supplied by L2 and C3.

An important layout issue arises due to the chopped nature of the currents flowing in Q1 and D1. If they are both tied directly to the ground plane before being combined, switching noise will be introduced into the ground plane. It is almost impossible to get rid of this noise, once present in the ground plane. The solution is to tie D1's cathode to the ground pin of the LT1611 before the combined currents are dumped into the ground plane as drawn in Figures 4, 5 and 6. This single layout technique can virtually eliminate high frequency "spike" noise so often present on switching regulator outputs.

Output ripple voltage appears as a triangular waveform riding on V_{OUT}. Ripple magnitude equals the ripple current of L2 multiplied by the equivalent series resistance (ESR) of output capacitor C3. Increasing the inductance of L1 and L2 lowers the ripple current, which leads to lower output voltage ripple. Decreasing the ESR of C3, by using ceramic or other low ESR type capacitors, lowers output ripple voltage. Output ripple voltage can be reduced to arbitrarily low levels by using large value inductors and low ESR, high value capacitors.

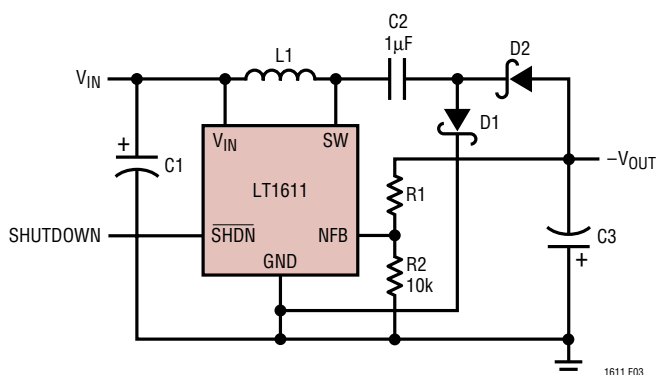

Figure 3. Direct Regulation of Negative Output Using Boost Converter with Charge Pump

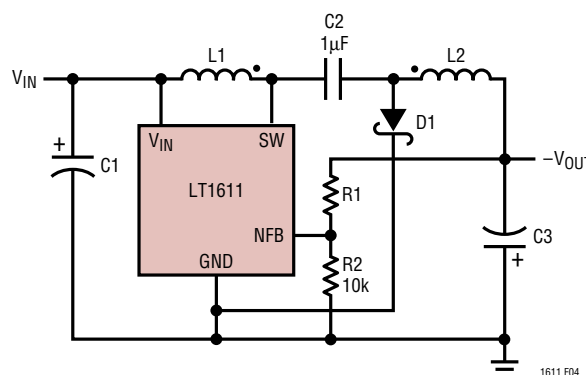

Figure 4. L2 Replaces D2 to Make Low Output Ripple Inverting Topology. Coupled or Uncoupled Inductors Can Be Used. Follow Phasing If Coupled for Best Results

OPERATION

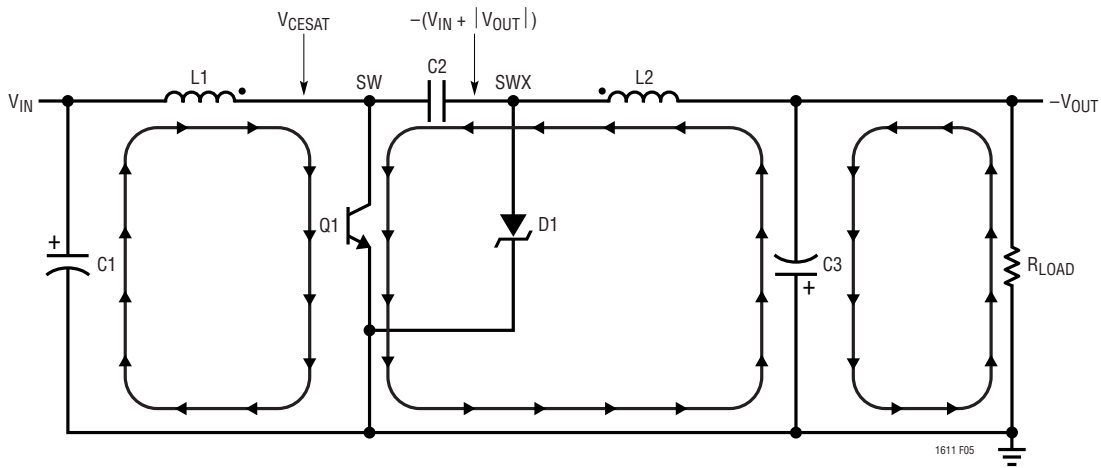

Figure 5. Switch-On Phase of Inverting Converter. L1 and L2 Current Have Positive di/dt

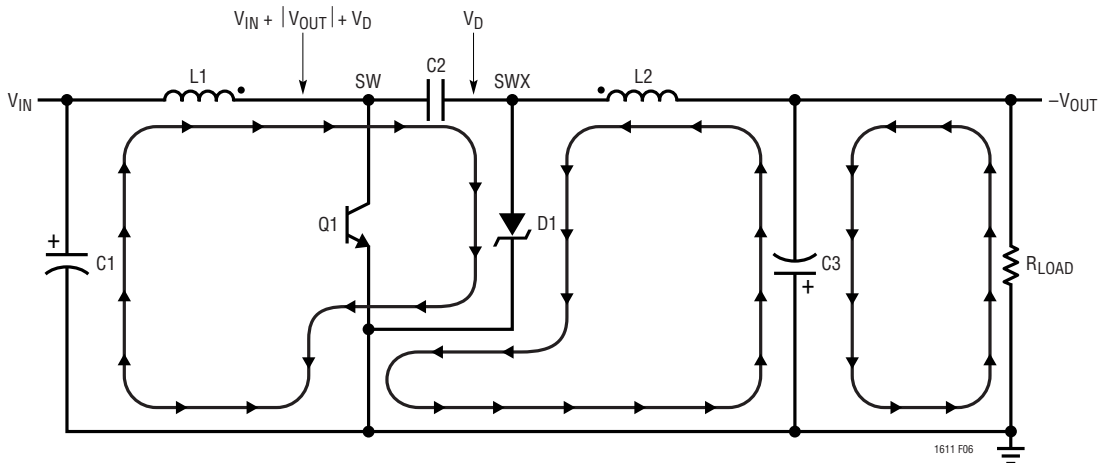

Figure 6. Switch-Off Phase of Inverting Converter. L1 and L2 Current Have Negative di/dt

Transient Response

The inverting architecture of the LT1611 can generate a very low ripple output voltage. Recently available high value ceramic capacitors can be used successfully in LT1611 designs with the addition of a phase lead capacitor, C_{PL} (see Figure 7). Connected in parallel with feedback resistor R_1 , this capacitor reduces both output perturba-

tions due to load steps and output ripple voltage to very low levels. To illustrate, Figure 7 shows an LT1611 inverting converter with resistor loads R_{L1} and R_{L2} . R_{L1} is connected across the output, while R_{L2} is switched in externally via a pulse generator. Output voltage waveforms are pictured in subsequent figures, illustrating the performance of output capacitor type and the effect of C_{PL} connected across R_1 .

OPERATION

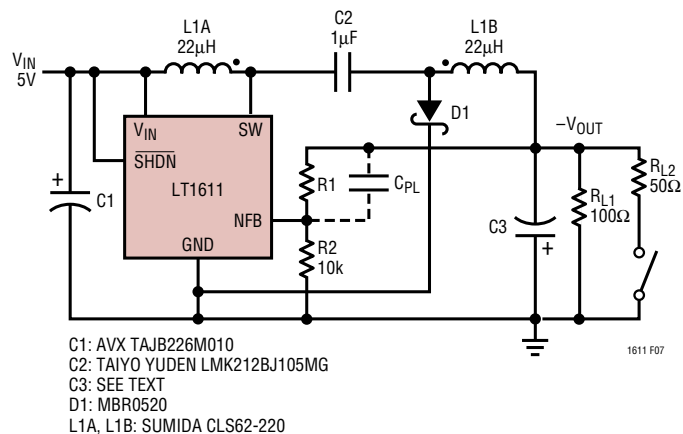

Figure 7. Switching R_{L2} Provides 50mA to 150mA Load Step for LT1611 5V to -5V Converter

Figure 8 shows the output voltage with a 50mA to 150mA load step, using an AVX TAJ “B” case 22μF tantalum capacitor at the output. Output perturbation is approximately 100mV as the load changes from 50mA to 150mA. Steady-state ripple voltage is 20mV_{p-p}, due to L1’s ripple current and C3’s ESR. Step response can be improved by adding a 3.3nF capacitor (C_{PL}) as shown in Figure 9. Settling time improves from 150μs to 40μs, although steady-state ripple voltage does not improve. Figure 10 pictures the output voltage and switch pin voltage at 200ns per division. Note the absence of high frequency spikes at the output. This is easily repeatable with proper layout, described in the next section.

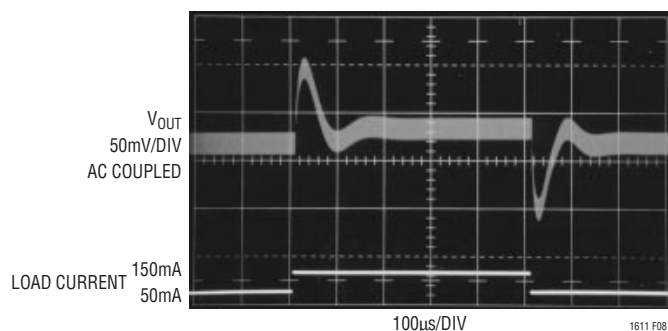

Figure 8. Load Step Response of LT1611 with 22μF Tantalum Output Capacitor

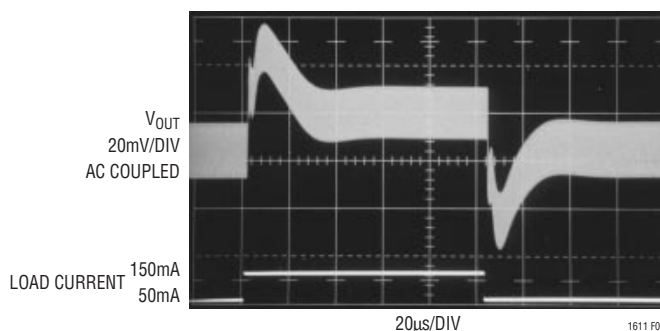

Figure 9. Addition of C_{PL} to Figure 7’s Circuit Improves Load Step Response. $C_{PL} = 3.3nF$

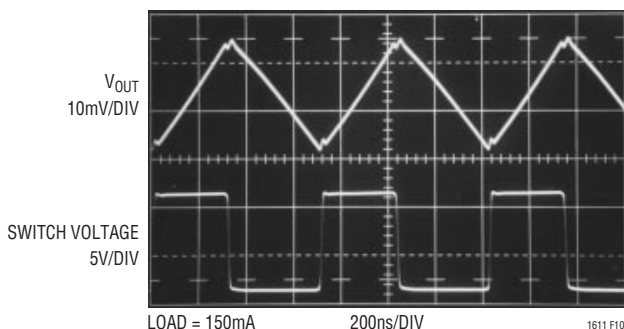

Figure 10. 22μF “B” Case Tantalum Capacitor (AVX TAJ “B” Series) Has ESR Resulting in 20mV_{p-p} Voltage Ripple at Output

OPERATION

In Figure 11 (also shown on the first page), output capacitor C3 is replaced by a ceramic unit. These large value ceramic capacitors have ESR of about $2\text{m}\Omega$ and result in very low output ripple. At the $20\text{mV}/\text{division}$ scale, output voltage ripple cannot be seen. Figure 12 pictures the output and switch nodes at 200ns per division. The output voltage ripple is approximately $1\text{mV}_{\text{P-P}}$. Again, good layout is mandatory to achieve this level of performance.

Layout

The LT1611 switches current at high speed, mandating careful attention to layout for best performance. *You will not get advertised performance with careless layout.* Figure 13 shows recommended component placement. Follow this closely in your printed circuit layout. The cut ground copper at D1's cathode is essential to obtain the low noise achieved in Figures 11 and 12's oscillographs. Input bypass capacitor C1 should be placed close to the LT1611 as shown. The load should connect directly to output capacitor C2 for best load regulation. You can tie the local ground into the system ground plane at C3's ground terminal.

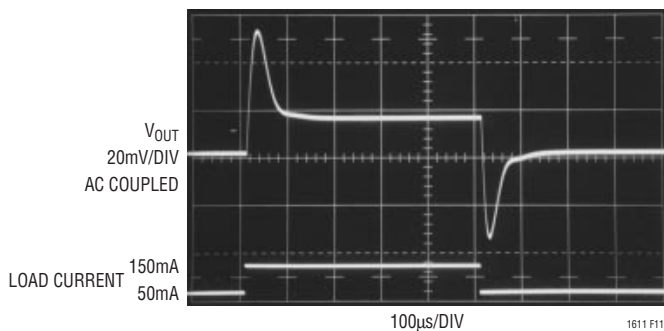

Figure 11. Replacing C3 with $22\mu\text{F}$ Ceramic Capacitor (Taiyo Yuden JMK325BJ226MM) Improves Output Noise. $C_{\text{PL}} = 1200\text{pF}$ Results in Best Phase Margin

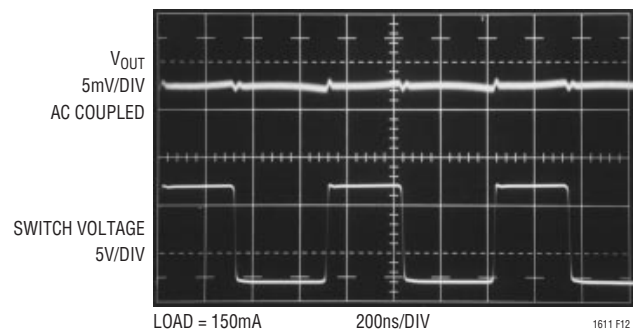

Figure 12. $22\mu\text{F}$ Ceramic Capacitor at Output Reduces Ripple to $1\text{mV}_{\text{P-P}}$. Proper Layout Is Essential to Achieve Low Noise

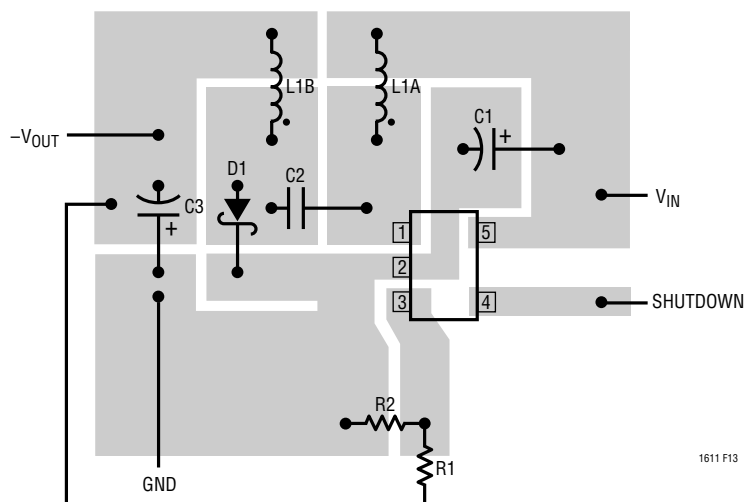

Figure 13. Suggested Component Placement. Note Cut in Ground Copper at D1's Cathode

OPERATION

Start-Up/Soft-Start

The LT1611, starting from $V_{OUT} = 0V$, reaches final voltage in approximately $450\mu s$ after SHDN is pulled high, with $C_{OUT} = 22\mu F$, $V_{IN} = 5V$ and $V_{OUT} = -5V$. Charging the output capacitor at this speed requires an inrush current of over 1A. If a longer start-up time is acceptable, a soft-start circuit consisting of R_{SS} and C_{SS} , as shown in Figure 14, can be used to limit inrush current to a lower value. Figure 15 pictures V_{OUT} and input current, starting into a 33 Ω load, with R_{SS} of 33k Ω and C_{SS} of 33nF. Input current,

measured at V_{IN} , is limited to a peak value of 450mA as the time required to reach final value increases to $700\mu s$. In Figure 16, C_{SS} is increased to $0.1\mu F$, resulting in a lower peak input current of 240mA with a V_{OUT} ramp time of 2.1ms. C_{SS} can be increased further for an even slower ramp, if desired. Diode D2 serves to quickly discharge C_{SS} when V_{SS} is driven low to shut down the device. D2 can be omitted, resulting in a “soft-stop” slow discharge of the output capacitor.

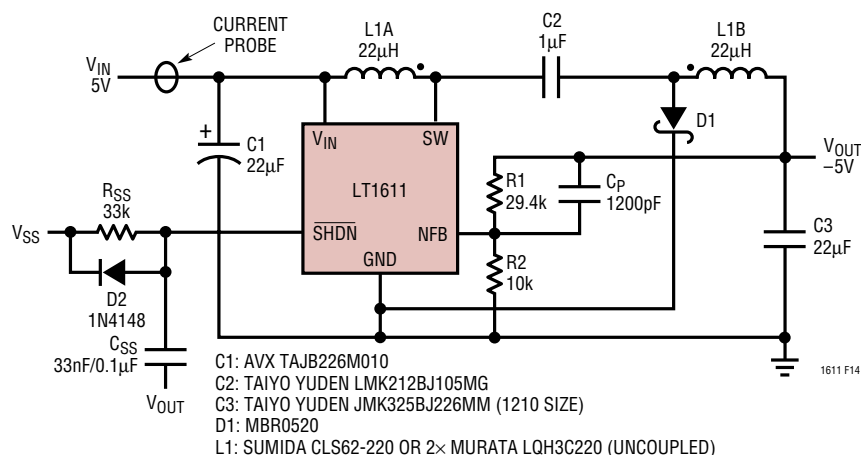

Figure 14. R_{SS} and C_{SS} at SHDN Pin Provide Soft-Start to LT1611 Inverting Converter

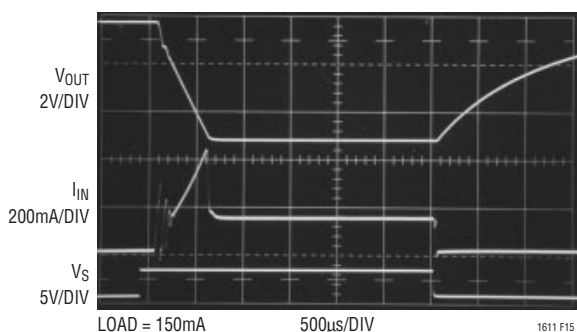

Figure 15. $R_{SS} = 33k$, $C_{SS} = 33nF$; V_{OUT} Reaches $-5V$ in $750\mu s$; Input Current Peaks at 450mA

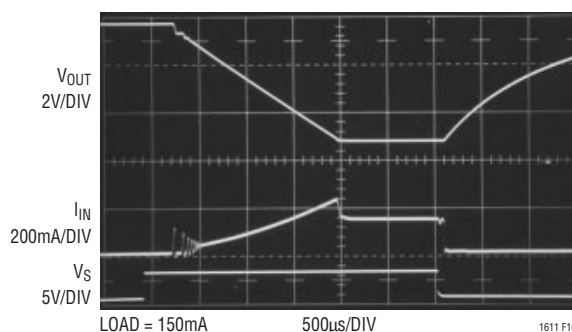

Figure 16. $R_{SS} = 33k$, $C_{SS} = 0.1\mu F$; V_{OUT} Reaches $-5V$ in 2.1ms; Input Current Peaks at 240mA

OPERATION

Output Current

The LT1611 will deliver 150mA at $-5V$ from a $5V \pm 10\%$ input supply. If a higher voltage supply is available, more output current can be obtained. Figure 17's schematic shows how to get more current. Although the LT1611's maximum voltage allowed at V_{IN} is 10V, the SW pin can handle higher voltage (up to 36V). In Figure 17, the V_{IN} pin of the LT1611 is driven from a 5V supply, while input inductor L_{1A} is driven from a separate 12V supply. Figure 18's graph shows maximum recommended output current as the voltage on L_{1A} is varied. Up to 300mA can be delivered when driving L_{1A} from a 12V supply.

COMPONENT SELECTION

Inductors

Each of the two inductors used with the LT1611 should have a saturation current rating (where inductance is approximately 70% of zero current inductance) of approximately 0.25A or greater. If the device is used in "charge pump" mode, where there is only one inductor, then its rating should be 0.5A or greater. DCR of the inductors should be 0.5Ω or less. A value of $22\mu H$ is suitable if using a coupled inductor such as Sumida CLS62-220 or Coiltronics CTX20-1. If using two separate inductors, increasing the value to $47\mu H$ will result in the same ripple current. Inductance can be reduced if operating from a supply voltage below 3V. Table 1 lists several inductors that will work with the LT1611, although this is not an exhaustive list. There are many magnetics vendors whose components are suitable.

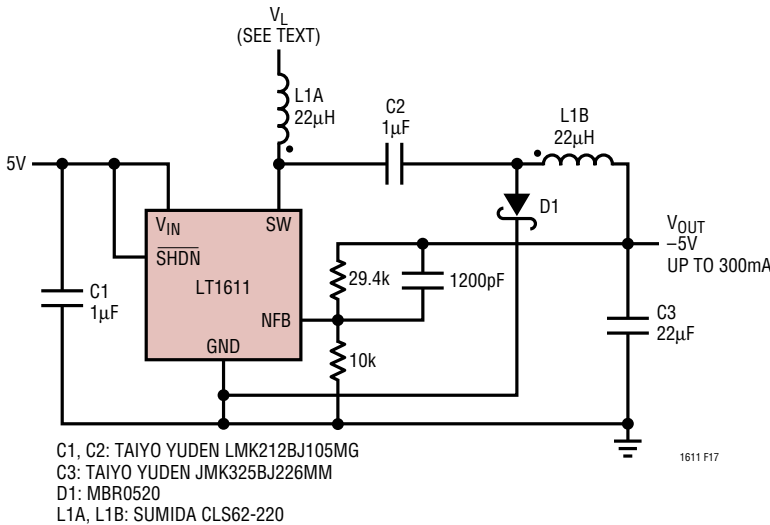

Figure 17. Increase Output Current By Driving L_{1A} from a Higher Voltage

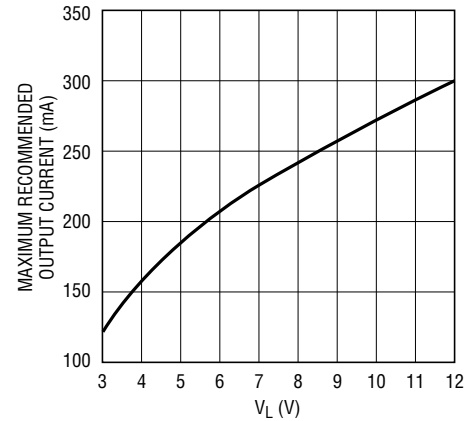

Figure 18. Output Current Increases to 300mA When Driving V_L from 12V Supply

OPERATION

Capacitors

As described previously, ceramic capacitors can be used with the LT1611 provided loop stability is considered. For lower cost applications, small tantalum units can be used. A value of 22 μ F is acceptable, although larger capacitance values can be used. ESR is the most important parameter in selecting an output capacitor. The “flying” capacitor (C2 in the schematic figures) should be a 1 μ F ceramic type. An X5R or X7R dielectric should be used to avoid capacitance decreasing severely with applied voltage. The input bypass capacitor is less critical, and either tantalum or

ceramic can be used with little trade-off in circuit performance. Some capacitor types appropriate for use with the LT1611 are listed in Table 2.

Diodes

A Schottky diode is recommended for use with the LT1611. The Motorola MBR0520 is a very good choice. Where the input to output voltage differential exceeds 20V, use the MBR0530 (a 30V diode). If cost is more important than efficiency, a 1N4148 can be used, but only at low current loads.

Table 1. Inductor Vendors

VENDOR	PHONE	URL	PART	COMMENT
Sumida	(847) 956-0666	www.sumida.com	CLS62-22022 CD43-470	22 μ H Coupled 47 μ H
Murata	(404) 436-1300	www.murata.com	LQH3C-220	22 μ H, 2mm Height
Coiltronics	(407) 241-7876	www.coiltronics.com	CTX20-1	20 μ H Coupled, Low DCR

Table 2. Capacitor Vendors

VENDOR	PHONE	URL	PART	COMMENT
Taiyo Yuden	(408) 573-4150	www.t-yuden.com	Ceramic Caps	X5R Dielectric
AVX	(803) 448-9411	www.avxcorp.com	Ceramic Caps Tantalum Caps	
Murata	(404) 436-1300	www.murata.com	Ceramic Caps	

TYPICAL APPLICATIONS

“Charge Pump” Inverting DC/DC Converter

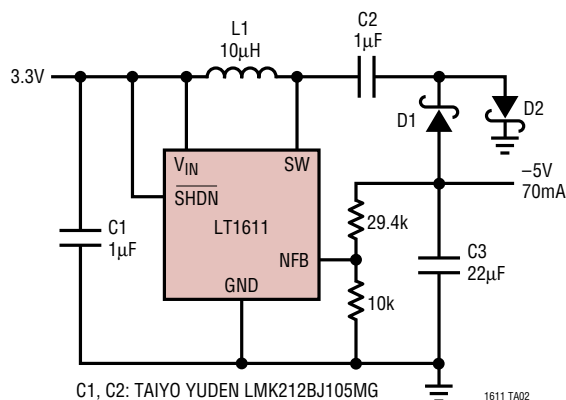

C1, C2: TAIYO YUDEN LMK212BJ105MG
 C3: TAIYO YUDEN JMK325BJ226MM
 D1, D2: MBR0520
 L1: MURATA LQH3C-100

TYPICAL APPLICATIONS

4-Cell to -10V Inverting Converter

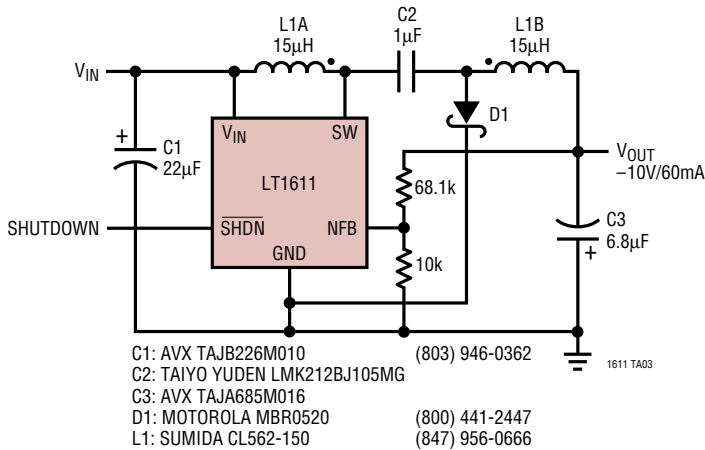

4-Cell to -10V Inverting Converter Efficiency

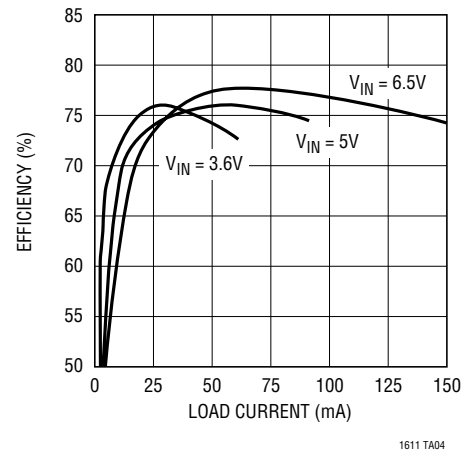

PACKAGE DESCRIPTION

Dimensions in inches (millimeters) unless otherwise noted.

S5 Package
 5-Lead Plastic SOT-23
 (LTC DWG # 05-08-1633)

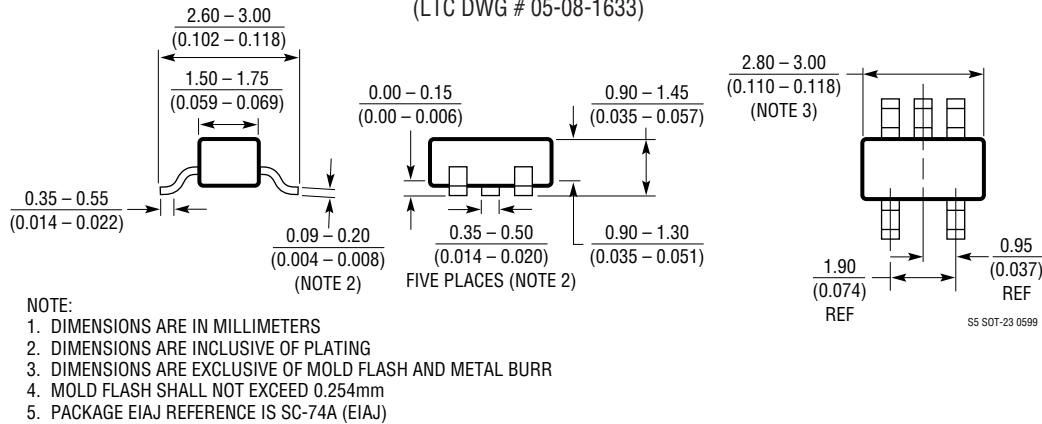

RELATED PARTS

PART NUMBER	DESCRIPTION	COMMENTS
LT1307	Single Cell Micropower DC/DC with Low Battery Detector	3.3V/75mA from 1V, 600kHz Fixed Frequency
LT1316	Burst Mode™ Operation DC/DC with Programmable Current Limit	1.5V Minimum VIN, Precise Control of Peak Switch Current
LT1317	2-Cell Micropower DC/DC with Low Battery Detector	3.3V/200mA from Two Cells, 600kHz Fixed Frequency
LT1370/LT1371	500kHz High Efficiency DC/DC Converter	42V, 6A/3A Internal Switch, Negative Feedback Regulation
LT1610	Single Cell Micropower DC/DC	3V/30mA from 1V, 1.7MHz Fixed Frequency, 30µA IQ
LT1613	1.4MHz SOT-23 Step-Up DC/DC Converter	5V at 200mA from 3.3V Input
LT1614	Inverting Mode Switching Regulator with Low-Battery Detector	-5V at 200mA from 5V Input in MSOP
LT1615	Micropower SOT-23 Step-Up DC/DC Converter	20µA Quiescent Current, VOUT Up to 34V
LT1617	Micropower SOT-23 Inverting Regulator	VOUT Up to -34V, 20µA Quiescent Current

Burst Mode is a trademark of Linear Technology Corporation.