

## Half-Bridge N-Channel Power MOSFET Driver with Boost Regulator

### FEATURES

- Floating Top Driver Switches Up to 60V
- Internal Boost Regulator for DC Operation
- Drives Gate of Top N-Channel MOSFET above Supply
- 180ns Transition Times Driving 10,000pF
- Adaptive Nonoverlapping Gate Drives Prevent Shoot-Through
- Top Drive Maintained at High Duty Cycles
- TTL/CMOS Input Levels
- Undervoltage Lockout with Hysteresis
- Operates at Supply Voltages from 10V to 15V
- Separate Top and Bottom Drive Pins

### APPLICATIONS

- PWM of High Current Inductive Loads
- Half-Bridge and Full-Bridge Motor Control
- Synchronous Step-Down Switching Regulators
- 3-Phase Brushless Motor Drive
- High Current Transducer Drivers
- Class D Power Amplifiers

### DESCRIPTION

The LT<sup>®</sup>1336 is a cost effective half-bridge N-channel power MOSFET driver. The floating driver can drive the topside N-channel power MOSFETs operating off a high voltage (HV) rail of up to 60V (absolute maximum). In PWM operation an on-chip switching regulator maintains charge in the bootstrap capacitor even when approaching and operating at 100% duty cycle.

The internal logic prevents the inputs from turning on the power MOSFETs in a half-bridge at the same time. Its unique adaptive protection against shoot-through currents eliminates all matching requirements for the two MOSFETs. This greatly eases the design of high efficiency motor control and switching regulator systems.

During low supply or start-up conditions, the undervoltage lockout actively pulls the driver outputs low to prevent the power MOSFETs from being partially turned on. The 0.5V hysteresis allows reliable operation even with slowly varying supplies.

LT, LTC and LT are registered trademarks of Linear Technology Corporation.

### TYPICAL APPLICATION

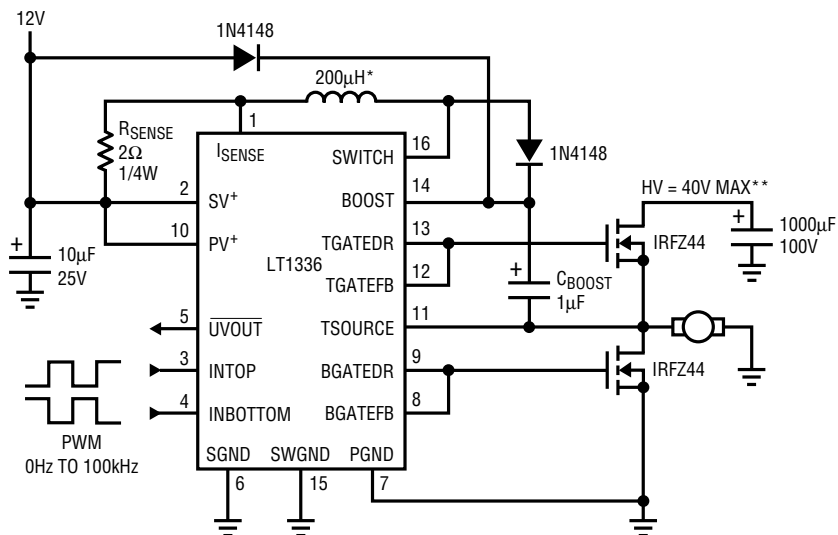

INTOP	INBOTTOM	TGATEDR	BGATEDR
L	L	L	L
L	H	L	H
H	L	H	L
H	H	L	L

\*SUMIDA RCR-664D-221KC

\*\*FOR HV > 40V SEE "DERIVING THE FLOATING SUPPLY WITH THE FLYBACK TOPOLOGY" IN APPLICATIONS INFORMATION SECTION

1336 TA01

**ABSOLUTE MAXIMUM RATINGS**

Supply Voltage (Pins 2, 10) .....	20V
Boost Voltage .....	75V
Peak Output Currents (< 10μs) .....	1.5A
Input Pin Voltages .....	-0.3V to V <sup>+</sup> + 0.3V
Top Source Voltage .....	-5V to 60V
Boost-to-Source Voltage (V <sub>BOOST</sub> - V <sub>TSOURCE</sub> ) .....	-0.3V to 20V
Switch Voltage (Pin 16) .....	-0.3V to 60V
Operating Temperature Range	
Commercial .....	0°C to 70°C
Industrial .....	-40°C to 85°C
Junction Temperature (Note 1) .....	125°C
Storage Temperature Range .....	-65°C to 150°C
Lead Temperature (Soldering, 10 sec) .....	300°C

**PACKAGE/ORDER INFORMATION**

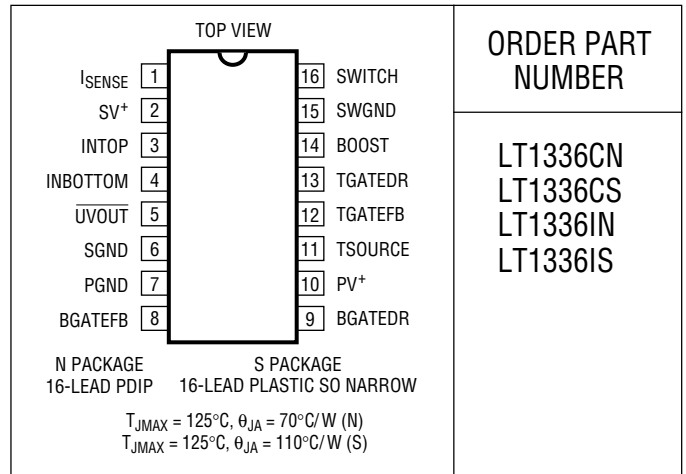

ORDER PART NUMBER

LT1336CN  
LT1336CS  
LT1336IN  
LT1336IS

Consult factory for Military grade parts.

**ELECTRICAL CHARACTERISTICS** Test Circuit, T<sub>A</sub> = 25°C, V<sup>+</sup> = V<sub>BOOST</sub> = 12V, V<sub>TSOURCE</sub> = 0V and Pins 1, 16 open. Gate Feedback pins connected to Gate Drive pins unless otherwise specified.

SYMBOL	PARAMETER	CONDITIONS	MIN	TYP	MAX	UNITS	
I <sub>S</sub>	DC Supply Current (Note 2)	V <sup>+</sup> = 15V, V <sub>INTOP</sub> = 0.8V, V <sub>INBOTTOM</sub> = 2V	12	15	20	mA	
		V <sup>+</sup> = 15V, V <sub>INTOP</sub> = 2V, V <sub>INBOTTOM</sub> = 0.8V	12	14	20	mA	
		V <sup>+</sup> = 15V, V <sub>INTOP</sub> = 0.8V, V <sub>INBOTTOM</sub> = 0.8V	12	15	20	mA	
		V <sup>+</sup> = 15V, V <sub>TSOURCE</sub> = 40V, V <sub>INTOP</sub> = V <sub>INBOTTOM</sub> = 0.8V (Note 3)		30	40	mA	
I <sub>BOOST</sub>	Boost Current (Note 2)	V <sup>+</sup> = 15V, V <sub>TSOURCE</sub> = 60V, V <sub>BOOST</sub> = 75V, V <sub>INTOP</sub> = V <sub>INBOTTOM</sub> = 0.8V	3	5	7	mA	
V <sub>IL</sub>	Input Logic Low		●	1.4	0.8	V	
V <sub>IH</sub>	Input Logic High		●	2	1.7	V	
I <sub>IN</sub>	Input Current	V <sub>INTOP</sub> = V <sub>INBOTTOM</sub> = 4V	●	7	25	μA	
V <sup>+</sup> <sub>UVH</sub>	V <sup>+</sup> Undervoltage Start-Up Threshold		8.4	8.9	9.4	V	
V <sup>+</sup> <sub>UVL</sub>	V <sup>+</sup> Undervoltage Shutdown Threshold		7.8	8.3	8.8	V	
V <sub>BUVH</sub>	V <sub>BOOST</sub> Undervoltage Start-Up Threshold	V <sub>TSOURCE</sub> = 60V, V <sub>BOOST</sub> - V <sub>TSOURCE</sub>	8.8	9.3	9.8	V	
V <sub>BUVL</sub>	V <sub>BOOST</sub> Undervoltage Shutdown Threshold	V <sub>TSOURCE</sub> = 60V, V <sub>BOOST</sub> - V <sub>TSOURCE</sub>	8.2	8.7	9.2	V	
I <sub>UVOUT</sub>	Undervoltage Output Leakage	V <sup>+</sup> = 15V	●	0.1	5	μA	
V <sub>UVOUT</sub>	Undervoltage Output Saturation	V <sup>+</sup> = 7.5V, I <sub>UVOUT</sub> = 2.5mA	●	0.2	0.4	V	
V <sub>OH</sub>	Top Gate ON Voltage	V <sub>INTOP</sub> = 2V, V <sub>INBOTTOM</sub> = 0.8V, V <sub>TGATE DR</sub> - V <sub>TSOURCE</sub>	●	11	11.3	12	V
	Bottom Gate ON Voltage	V <sub>INTOP</sub> = 0.8V, V <sub>INBOTTOM</sub> = 2V, V <sub>BGATE DR</sub>	●	11	11.3	12	V
V <sub>OL</sub>	Top Gate OFF Voltage	V <sub>INTOP</sub> = 0.8V, V <sub>INBOTTOM</sub> = 2V, V <sub>TGATE DR</sub> - V <sub>TSOURCE</sub>	●	0.4	0.7	V	
	Bottom Gate OFF Voltage	V <sub>INTOP</sub> = 2V, V <sub>INBOTTOM</sub> = 0.8V, V <sub>BGATE DR</sub>	●	0.4	0.7	V	

## ELECTRICAL CHARACTERISTICS

Test Circuit,  $T_A = 25^\circ\text{C}$ ,  $V^+ = V_{\text{BOOST}} = 12\text{V}$ ,  $V_{\text{TSOURCE}} = 0\text{V}$ , and Pins 1, 16 open. Gate Feedback pins connected to Gate Drive pins unless otherwise specified.

SYMBOL	PARAMETER	CONDITIONS	MIN	TYP	MAX	UNITS
$V_{\text{IS}}$	$I_{\text{SENSE}}$ Peak Current Threshold	$V_{\text{TSOURCE}} = 60\text{V}$ , $V_{\text{BOOST}} = 68\text{V}$ , $V^+ - V_{\text{ISENSE}}$	310	480	650	mV
$V_{\text{ISHYS}}$	$I_{\text{SENSE}}$ Hysteresis	$V_{\text{TSOURCE}} = 60\text{V}$ , $V_{\text{BOOST}} = 68\text{V}$	25	55	85	mV
$V_{\text{SAT}}$	Switch Saturation Voltage	$V_{\text{ISENSE}} = V^+$ , $V_{\text{BOOST}} - V_{\text{TSOURCE}} = 9\text{V}$ , $I_{\text{SW}} = 100\text{mA}$	●	0.85	1.2	V
$V_{\text{BOUT}}$	$V_{\text{BOOST}}$ Regulated Output	$V_{\text{TSOURCE}} = 40\text{V}$ , $V_{\text{INTOP}} = V_{\text{INBOTTOM}} = 0.8\text{V}$ , $I_{\text{BOOST}} = 10\text{mA}$ , $V_{\text{BOOST}} - V_{\text{TSOURCE}}$	10	10.6	11.2	V
$t_r$	Top Gate Rise Time	$V_{\text{INTOP}} (+)$ Transition, $V_{\text{INBOTTOM}} = 0.8\text{V}$ , Measured at $V_{\text{TGATE DR}} - V_{\text{TSOURCE}}$ (Note 4)	●	130	200	ns
	Bottom Gate Rise Time	$V_{\text{INBOTTOM}} (+)$ Transition, $V_{\text{INTOP}} = 0.8\text{V}$ , Measured at $V_{\text{BGATE DR}}$ (Note 4)	●	90	200	ns
$t_f$	Top Gate Fall Time	$V_{\text{INTOP}} (-)$ Transition, $V_{\text{INBOTTOM}} = 0.8\text{V}$ , Measured at $V_{\text{TGATE DR}} - V_{\text{TSOURCE}}$ (Note 4)	●	60	140	ns
	Bottom Gate Fall Time	$V_{\text{INBOTTOM}} (-)$ Transition, $V_{\text{INTOP}} = 0.8\text{V}$ , Measured at $V_{\text{BGATE DR}}$ (Note 4)	●	60	140	ns
$t_{\text{D1}}$	Top Gate Turn-On Delay	$V_{\text{INTOP}} (+)$ Transition, $V_{\text{INBOTTOM}} = 0.8\text{V}$ , Measured at $V_{\text{TGATE DR}} - V_{\text{TSOURCE}}$ (Note 4)	●	250	500	ns
	Bottom Gate Turn-On Delay	$V_{\text{INBOTTOM}} (+)$ Transition, $V_{\text{INTOP}} = 0.8\text{V}$ , Measured at $V_{\text{BGATE DR}}$ (Note 4)	●	200	400	ns
$t_{\text{D2}}$	Top Gate Turn-Off Delay	$V_{\text{INTOP}} (-)$ Transition, $V_{\text{INBOTTOM}} = 0.8\text{V}$ , Measured at $V_{\text{TGATE DR}} - V_{\text{TSOURCE}}$ (Note 4)	●	300	600	ns
	Bottom Gate Turn-Off Delay	$V_{\text{INBOTTOM}} (-)$ Transition, $V_{\text{INTOP}} = 0.8\text{V}$ , Measured at $V_{\text{BGATE DR}}$ (Note 4)	●	200	400	ns
$t_{\text{D3}}$	Top Gate Lockout Delay	$V_{\text{INBOTTOM}} (+)$ Transition, $V_{\text{INTOP}} = 2\text{V}$ , Measured at $V_{\text{TGATE DR}} - V_{\text{TSOURCE}}$ (Note 4)	●	300	600	ns
	Bottom Gate Lockout Delay	$V_{\text{INTOP}} (+)$ Transition, $V_{\text{INBOTTOM}} = 2\text{V}$ , Measured at $V_{\text{BGATE DR}}$ (Note 4)	●	250	500	ns
$t_{\text{D4}}$	Top Gate Release Delay	$V_{\text{INBOTTOM}} (-)$ Transition, $V_{\text{INTOP}} = 2\text{V}$ , Measured at $V_{\text{TGATE DR}} - V_{\text{TSOURCE}}$ (Note 4)	●	250	500	ns
	Bottom Gate Release Delay	$V_{\text{INTOP}} (-)$ Transition, $V_{\text{INBOTTOM}} = 2\text{V}$ , Measured at $V_{\text{BGATE DR}}$ (Note 4)	●	200	400	ns

The ● denotes specifications which apply over the full operating temperature range.

**Note 1:**  $T_J$  is calculated from the ambient temperature  $T_A$  and power dissipation  $P_D$  according to the following formulas:

$$\text{LT1336CN/LT1336IN: } T_J = T_A + (P_D)(70^\circ\text{C/W})$$

$$\text{LT1336CS/LT1336IS: } T_J = T_A + (P_D)(110^\circ\text{C/W})$$

**Note 2:** Dynamic supply current is higher due to the gate charge being delivered at the switching frequency. See Typical Performance Characteristics and Applications Information sections.

**Note 3:** Pins 1 and 16 connected to each end of the inductor. Booster is free running.

**Note 4:** See Timing Diagram. Gate rise times are measured from 2V to 10V and fall times are measured from 10V to 2V. Delay times are measured from the input transition to when the gate voltage has risen to 2V or decreased to 10V.

# TYPICAL PERFORMANCE CHARACTERISTICS

**DC Supply Current vs Supply Voltage**

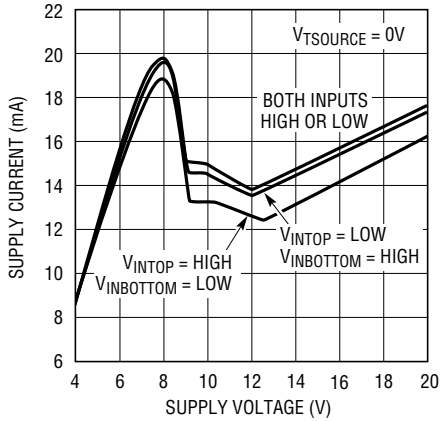

1336 G01

**DC Supply Current vs Temperature**

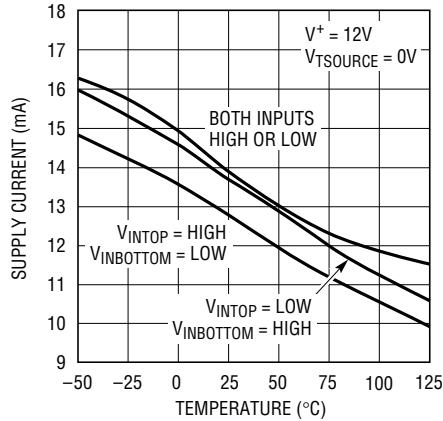

1336 G02

**DC Supply Current vs Top Source Voltage**

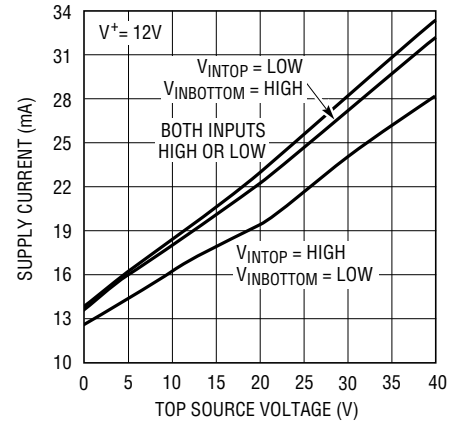

1336 G18

**DC + Dynamic Supply Current vs Input Frequency**

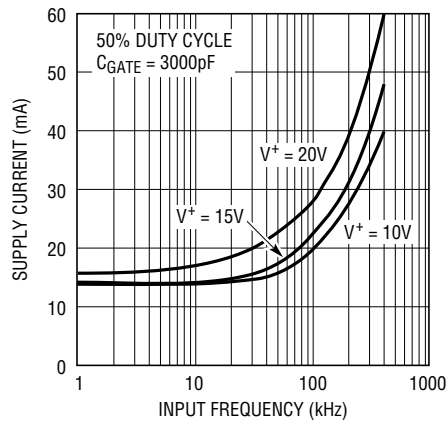

1336 G03

**DC + Dynamic Supply Current vs Input Frequency**

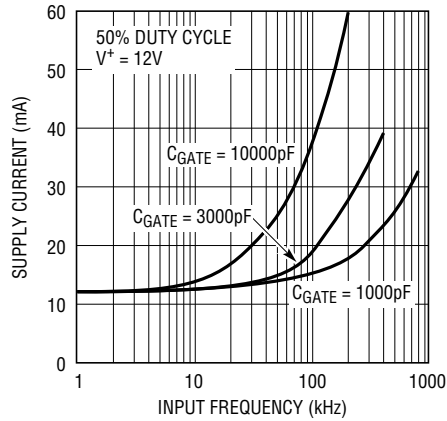

1336 G04

**Undervoltage Lockout (V+)**

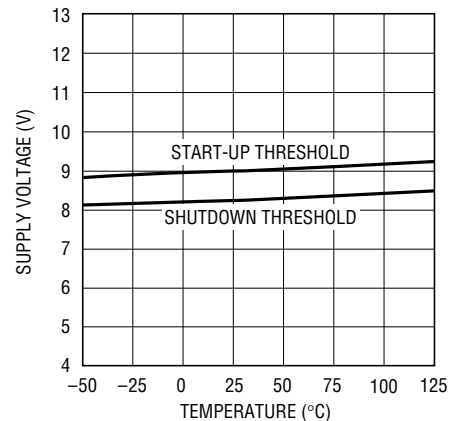

1336 G05

**Undervoltage Lockout (V\_BOOST)**

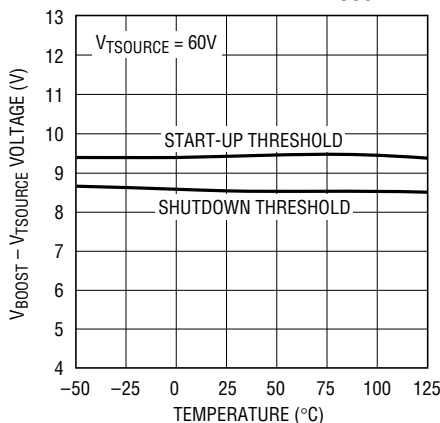

1336 G06

**Input Threshold Voltage vs Temperature**

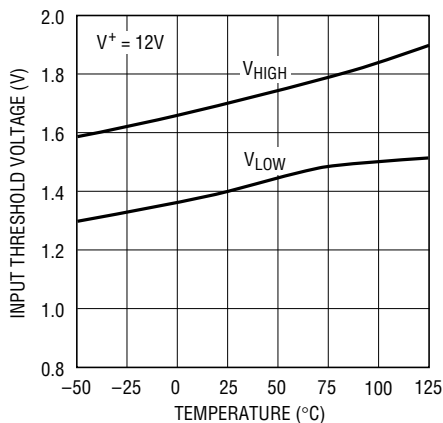

1336 G07

**Top or Bottom Input Pin Current vs Temperature**

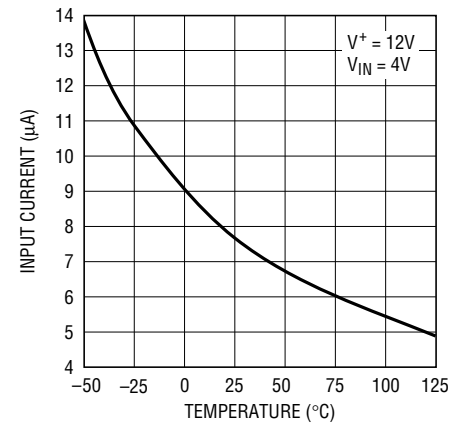

1336 G08

# TYPICAL PERFORMANCE CHARACTERISTICS

**Top or Bottom Input Pin Current vs Input Voltage**

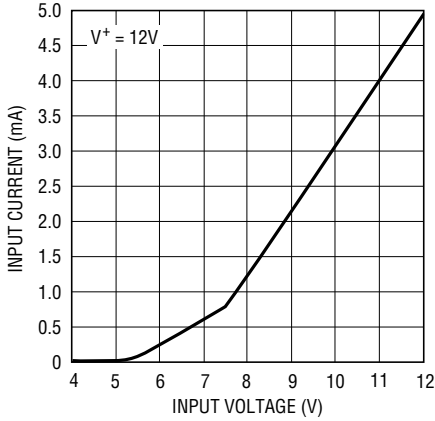

1336 G09

**Bottom Gate Rise Time vs Temperature**

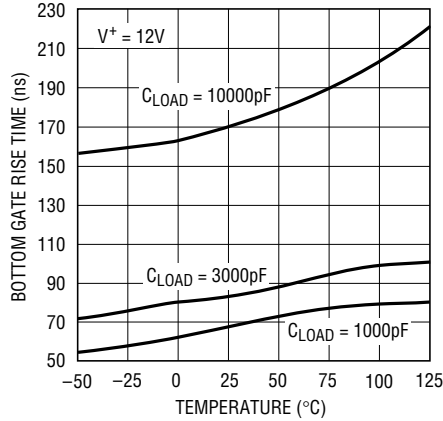

1336 G10

**Bottom Gate Fall Time vs Temperature**

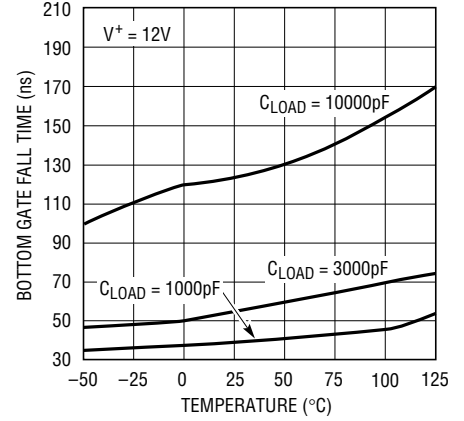

1336 G11

**Top Gate Rise Time vs Temperature**

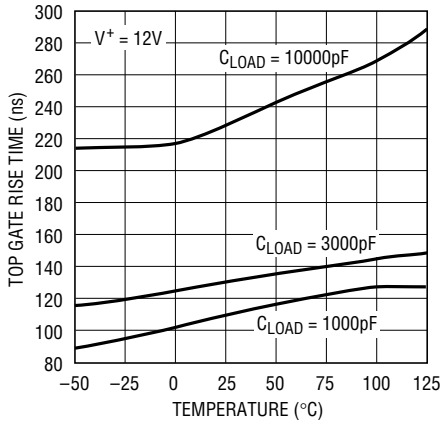

1336 G12

**Top Gate Fall Time vs Temperature**

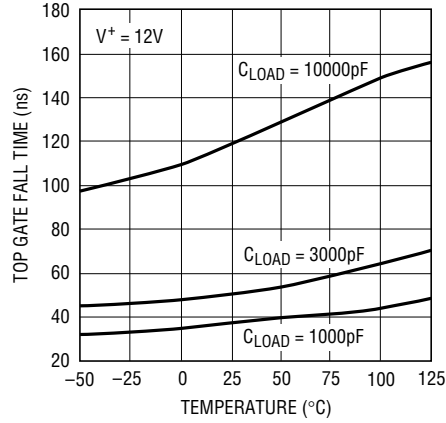

1336 G13

**Turn-On Delay Time vs Temperature**

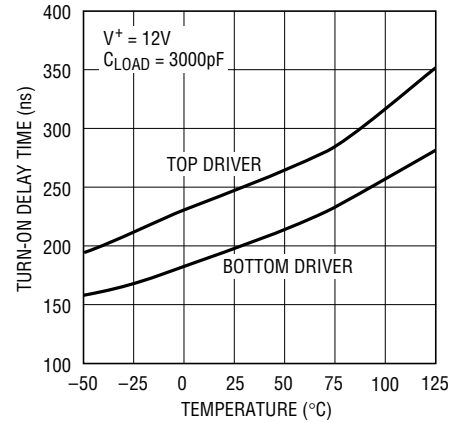

1336 G14

**Turn-Off Delay Time vs Temperature**

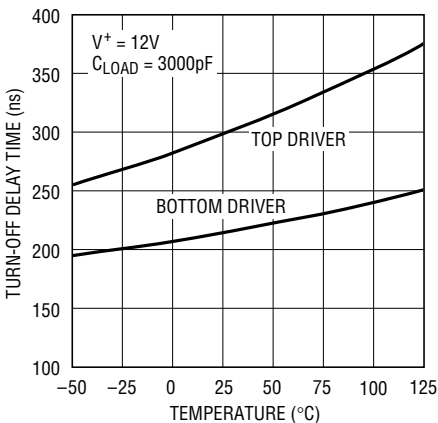

1336 G15

**Lockout Delay Time vs Temperature**

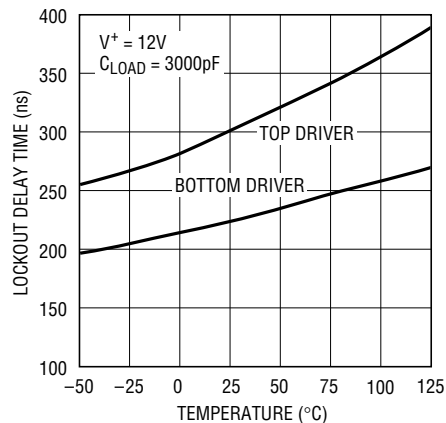

1336 G16

**Release Delay Time vs Temperature**

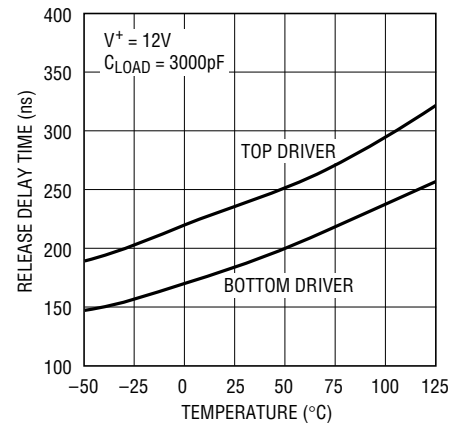

1336 G17

## TYPICAL PERFORMANCE CHARACTERISTICS

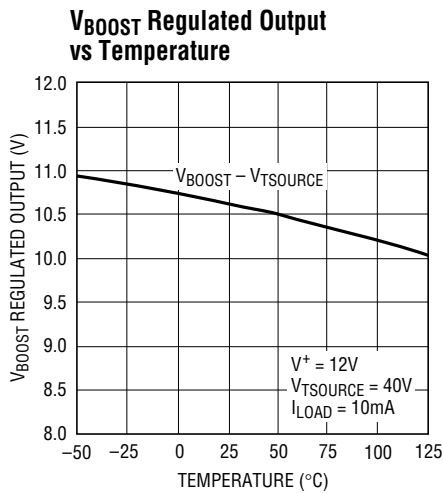

1336 G19

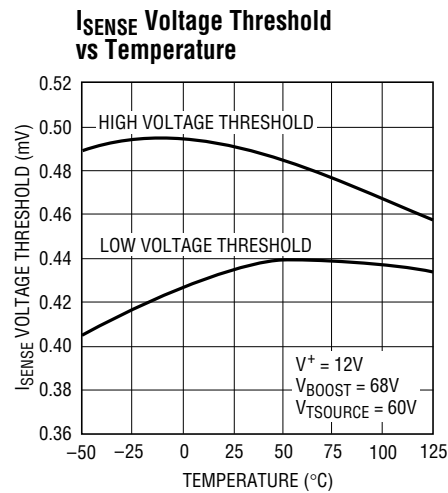

1336 G20

## PIN FUNCTIONS

**I<sub>SENSE</sub> (Pin 1):** Boost Regulator I<sub>SENSE</sub> Comparator Input. An R<sub>SENSE</sub> placed between Pin 1 and V<sup>+</sup> sets the maximum peak current. Pin 1 can be left open if the boost regulator is not used.

**SV<sup>+</sup> (Pin 2):** Main Signal Supply. Must be closely decoupled to the signal ground Pin 6.

**INTOP (Pin 3):** Top Driver Input. Pin 3 is disabled when Pin 4 is high. A 3k input resistor followed by a 5V internal clamp prevents saturation of the input transistors.

**INBOTTOM (Pin 4):** Bottom Driver Input. Pin 4 is disabled when Pin 3 is high. A 3k input resistor followed by a 5V internal clamp prevents saturation of the input transistors.

**UVOUT (Pin 5):** Undervoltage Output. Open collector NPN output which turns on when V<sup>+</sup> drops below the undervoltage threshold.

**SGND (Pin 6):** Small-Signal Ground. Must be routed separately from other grounds to the system ground.

**PGND (Pin 7):** Bottom Driver Power Ground. Connects to source of bottom N-channel MOSFET.

**BGATEFB (Pin 8):** Bottom Gate Feedback. Must connect directly to the bottom power MOSFET gate. The top MOSFET turn-on is inhibited until Pin 8 has discharged to below 2.5V.

**BGATEDR (Pin 9):** Bottom Gate Drive. The high current drive point for the bottom MOSFET. When a gate resistor is used it is inserted between Pin 9 and the gate of the MOSFET.

**PV<sup>+</sup> (Pin 10):** Bottom Driver Supply. Must be connected to the same supply as Pin 2.

**TSOURCE (Pin 11):** Top Driver Return. Connects to the top MOSFET source and the low side of the bootstrap capacitor.

**TGATEFB (Pin 12):** Top Gate Feedback. Must connect directly to the top power MOSFET gate. The bottom MOSFET turn-on is inhibited until V<sub>TGATE FB</sub> - V<sub>TSOURCE</sub> has discharged to below 2.9V.

**TGATEDR (Pin 13):** Top Gate Drive. The high current drive point for the top MOSFET. When a gate resistor is used it is inserted between Pin 13 and the gate of the MOSFET.

**BOOST (Pin 14):** Top Driver Supply. Connects to the high side of the bootstrap capacitor.

**SWGND (Pin 15):** Boost Regulator Ground. Must be routed separately from the other grounds to the system ground. Pin 15 can be left open if the boost regulator is not used.

**SWITCH (Pin 16):** Boost Regulator Switch. Connect this pin to the inductor/diode of the boost regulator network. Pin 16 can be left open if the boost regulator is not used.

# FUNCTIONAL DIAGRAM

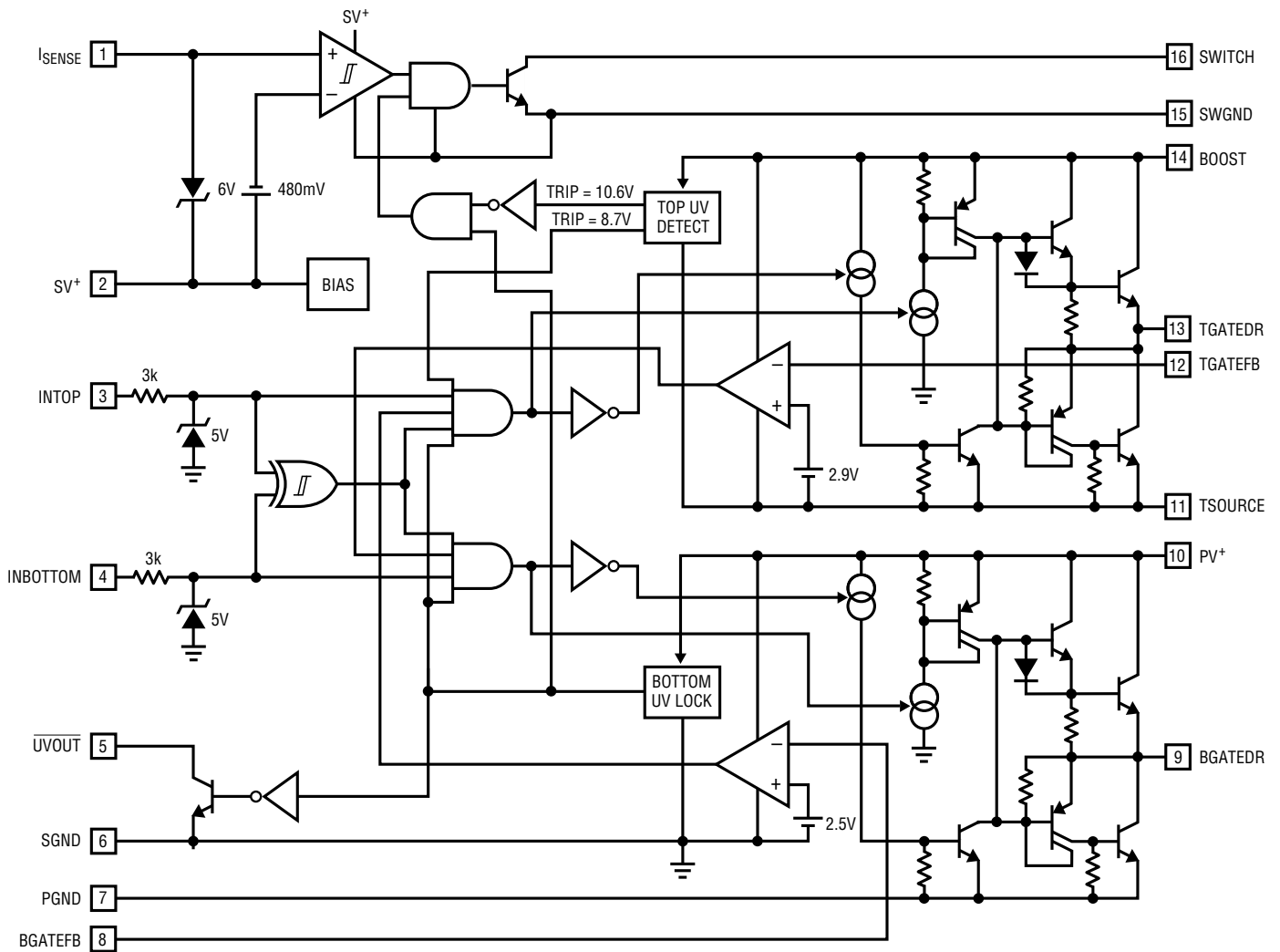

1336 FD

**TEST CIRCUIT**

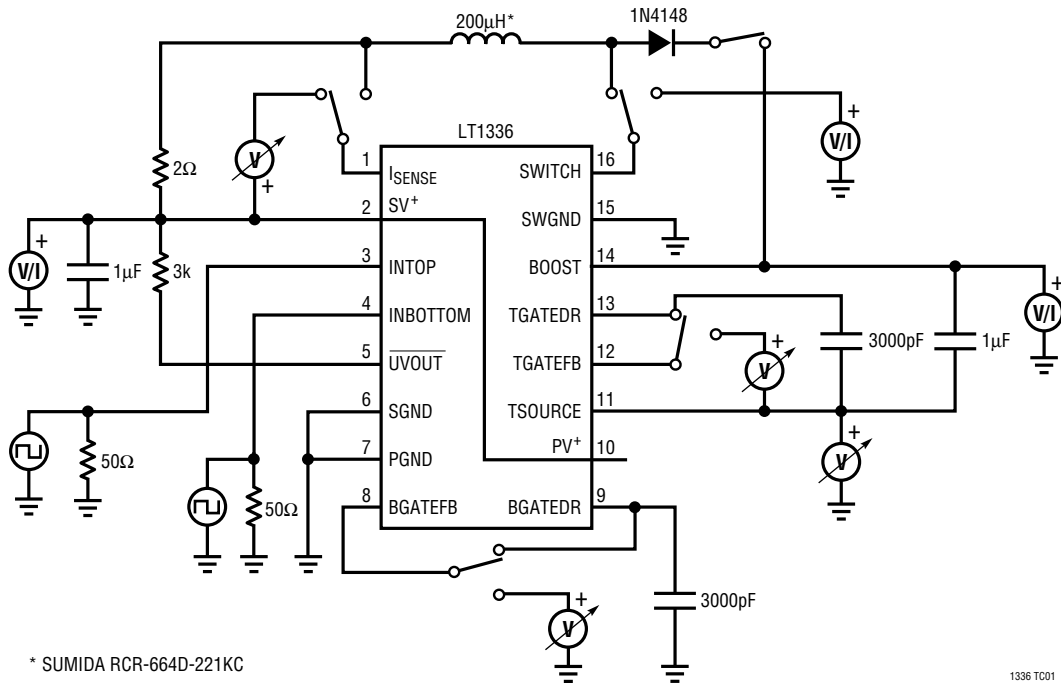

**TIMING DIAGRAM**

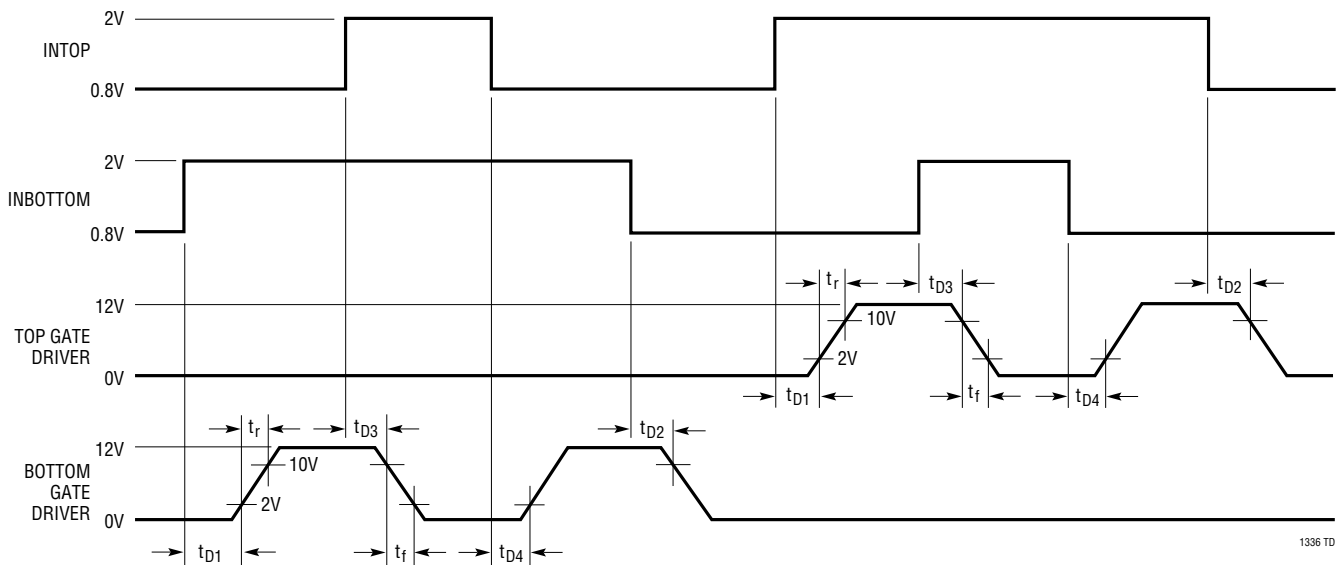



## OPERATION (Refer to Functional Diagram)

The LT1336 incorporates two independent driver channels with separate inputs and outputs. The inputs are TTL/CMOS compatible; they can withstand input voltages as high as  $V^+$ . The 1.4V input threshold is regulated and has 300mV of hysteresis. Both channels are noninverting drivers. The internal logic prevents both outputs from simultaneously turning on under any input conditions. When both inputs are high both outputs are actively held low.

An internal switching regulator permits smooth transition from PWM to DC operation. In PWM operation the bootstrap capacitor is recharged each time Top Source pin goes low. As the duty cycle approaches 100% the output pulse width becomes narrower and the time available to produce an elevated upper MOSFET gate supply becomes shorter than required. As the voltage across the bootstrap capacitor drops below 10.6V, an inductor-based switching regulator kicks in and takes over the charging of the

floating supply. This allows the output to smoothly transition to 100% duty cycle.

An undervoltage detection circuit disables both channels when  $V^+$  is below the undervoltage trip point. A separate undervoltage detect block disables the high side channel when  $V_{\text{BOOST}} - V_{\text{TSOURCE}}$  is below 9V.

The top and bottom gate drivers in the LT1336 each utilize two gate connections: 1) a Gate Drive pin, which provides the turn-on and turn-off currents through an optional series gate resistor, and 2) a Gate Feedback pin which connects directly to the gate to monitor the gate-to-source voltage.

Whenever there is an input transition to command the outputs to change states, the LT1336 follows a logical sequence to turn off one MOSFET and turn on the other. First, turn-off is initiated, then  $V_{\text{GS}}$  is monitored until it has decreased below the turn-off threshold, and finally the other gate is turned on.

## APPLICATIONS INFORMATION

### Deriving the Floating Supply

In a typical half-bridge driver like the LT1158 or the LT1160, the floating supply for the topside driver is provided by a bootstrap capacitor. This capacitor is recharged each time its negative plate goes low in PWM operation. As the duty cycle approaches 100% the output pulse width becomes narrower and the time available to recharge the bootstrap capacitor becomes shorter than required (1 $\mu$ s to 2 $\mu$ s). For instance, at 100kHz and at 95% duty cycle the output pulse width is only 0.5 $\mu$ s; clearly this is insufficient time to recharge the capacitor by bootstrapping. To get around this problem, the LT1336 incorporates a switching regulator to help recharge the bootstrap capacitor under such extreme conditions.

The LT1336 provides all the necessary circuitry to construct a boost or flyback switching regulator. This regulator can charge the bootstrap capacitor when it cannot recharge by bootstrapping. This happens when nearing 100% duty cycle in PWM applications. This is a worst-case condition because the bootstrap capacitor must still provide for the gate charging current of the high side

MOSFETs. A diode connected between  $V^+$  and the Boost pin is still needed to allow conventional bootstrapping of the bootstrap capacitor when duty cycles are below 90%.

The LT1336's internal switching regulator can provide enough charge to the bootstrap capacitor to allow the top driver to drive several power MOSFETs in parallel at its maximum operating frequency. The regulated voltage across  $V_{\text{BOOST}} - V_{\text{TSOURCE}}$  is 10.6V; when this voltage is exceeded due to normal bootstrap action, the regulator automatically shuts down.

The switching regulator uses a hysteretic current mode control. This method of control is simple, inherently stable and provides peak inductor current limit in every cycle. It is designed to run at a nominal frequency of around 700kHz which is 7 $\times$  the maximum PWM operating frequency of the LT1336. Since the hysteretic current mode control has no internal oscillator, the frequency is determined by external conditions such as supply voltage and load currents and external components such as inductor value and current sense resistor value.

## APPLICATIONS INFORMATION

In applications where switching is always above 10kHz and the duty cycle never exceeds 90%, Pins 1, 15 and 16 can be left open. The bootstrap capacitor is then charged by conventional bootstrapping. Only a diode needs to be connected between  $V^+$  and the Boost pin. A  $0.1\mu\text{F}$  bootstrap capacitor is usually adequate using this technique for driving a single MOSFET under  $10,000\text{pF}$ . When driving multiple MOSFETs in parallel, if the total gate capacitance exceeds  $10,000\text{pF}$ , the bootstrap capacitor should be increased proportionally above  $0.1\mu\text{F}$  (see Paralleling MOSFETs).

### Deriving the Floating Supply with the Boost Topology

The advantage of using the boost topology is its simplicity. Only a resistor, a small inductor, a diode and a capacitor are needed. However, the high voltage rail may not exceed 40V to avoid reaching the collector-base breakdown voltage of the internal NPN switch.

The recommended values for the current sense resistor, inductor and bootstrap capacitor are  $2\Omega$ ,  $200\mu\text{H}$  and  $1\mu\text{F}$  respectively. Using the recommended component values the boost regulator will run at around 700kHz. To lower the frequency the inductor value can be increased and to increase the frequency the inductor value can be decreased. The sense resistor should be at least  $1.5\Omega$  to maintain adequate inductor current limit. The bootstrap capacitor value should be  $1\mu\text{F}$  or larger to minimize ripple voltage. An example of a boost regulator is shown in Figure 1.

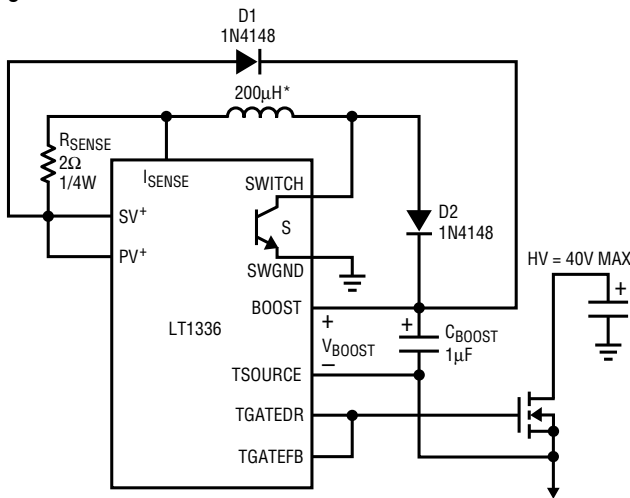

\* SUMIDA RCR-664D-221KC

1336 F01

Figure 1. Using the Boost Regulator

The boost regulator works as follows: when switch S is on, the inductor current ramps up as the magnetic field builds up. During this interval energy is being stored in the inductor and no power is transferred to  $V_{\text{BOOST}}$ . When the inductor peak current is reached, sensed by the  $2\Omega$  resistor, the switch is turned off. Energy is no longer transferred to the inductor causing the magnetic field to collapse. The collapsing magnetic field induces a change in voltage across the inductor. The Switch pin voltage rises until diode D2 starts conducting. As the inductor current ramps down, the lower inductor current threshold is reached and switch S is turned off, thus completing the cycle.

Current drawn from  $V^+$  is delivered to  $V_{\text{BOOST}}$ . Some of this current ( $\sim 1.5\text{mA}$ ) flows through the topside driver to the Top Source pin. This current is typically returned to ground via the bottom MOSFET or the output load. If the bottom MOSFET were off and the output load were returned to HV, then the Top Source pin will return the current to HV through the top MOSFET or the output load. If the HV supply cannot sink current and no load drawing greater than  $1.5\text{mA}$  is connected to the supply, then a resistor from HV to ground may be needed to prevent voltage buildup on the HV supply.

Note that the current drawn from  $V^+$  and delivered to  $V_{\text{BOOST}}$  is significantly higher than the current drawn from  $V_{\text{BOOST}}$  as given by:

$$I_{\text{IN}}(V^+) = I_{\text{OUT}} \left( \frac{V_{\text{BOOST}}}{V^+} \right)$$

### Deriving the Floating Supply with the Flyback Topology

For applications where the high voltage rail is greater than 40V, the flyback topology must be used. To configure a flyback regulator, a resistor, a diode, a small 1:1 turns ratio transformer and a capacitor are needed. The maximum voltage across the switch, assuming an ideal transformer, will be about  $V^+ + 11.3\text{V}$ . Leakage inductance in nonideal transformers will induce an overvoltage spike at the switch at the instant when it opens. These spikes can be clamped using a snubbing network or a Zener. Unlike the boost topology, the current drawn from  $V^+$  (assuming no loss) is equal to the current drawn from  $V_{\text{BOOST}}$ .

## APPLICATIONS INFORMATION

Using the components as shown in Figure 2 the flyback regulator will run at around 800kHz. To lower the frequency  $C_{FILTER}$  can be increased and to increase the frequency  $C_{FILTER}$  can be decreased.

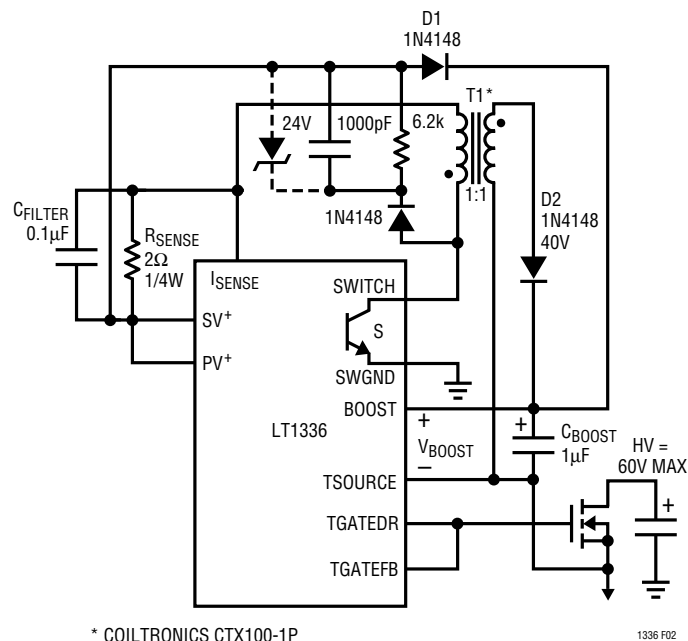

Figure 2. Using the Flyback Regulator

The flyback regulator works as follows: when switch S is on, the primary current ramps up as the magnetic field builds up. The magnetic field in the core induces a voltage on the secondary winding equal to  $V^+$ . However, no power is transferred to  $V_{BOOST}$  because the rectifier diode D2 is reverse biased. The energy is stored in the transformer's magnetic field. When the primary inductor peak current is reached, the switch is turned off. Energy is no longer transferred to the transformer causing the magnetic field to collapse. The collapsing magnetic field induces a change in voltage across the transformer's windings. During this transition the Switch pin's voltage flies to 10.6V plus a diode above  $V^+$ , the secondary forward biases the rectifier diode D2 and the transformer's energy is transferred to  $V_{BOOST}$ . Meanwhile the primary inductor current goes to zero and the voltage at  $I_{SENSE}$  decays to the lower inductor current threshold with a time constant of  $(R_{SENSE})(C_{FILTER})$ , thus completing the cycle.

### Power MOSFET Selection

Since the LT1336 inherently protects the top and bottom MOSFETs from simultaneous conduction, there are no size or matching constraints. Therefore, selection can be made based on the operating voltage and  $R_{DS(ON)}$  requirements. The MOSFET  $BV_{DSS}$  should be at least equal to the LT1336 absolute maximum operating voltage. For a maximum operating HV supply of 60V, the MOSFET  $BV_{DSS}$  should be from 60V to 100V.

The MOSFET  $R_{DS(ON)}$  is specified at  $T_J = 25^\circ C$  and is generally chosen based on the operating efficiency required as long as the maximum MOSFET junction temperature is not exceeded. The dissipation in each MOSFET is given by:

$$P = D(I_{DS})^2(1 + \partial)R_{DS(ON)}$$

where D is the duty cycle and  $\partial$  is the increase in  $R_{DS(ON)}$  at the anticipated MOSFET junction temperature. From this equation the required  $R_{DS(ON)}$  can be derived:

$$R_{DS(ON)} = \frac{P}{D(I_{DS})^2(1 + \partial)}$$

For example, if the MOSFET loss is to be limited to 2W when operating at 5A and a 90% duty cycle, the required  $R_{DS(ON)}$  would be  $0.089\Omega/(1 + \partial)$ .  $(1 + \partial)$  is given for each MOSFET in the form of a normalized  $R_{DS(ON)}$  vs temperature curve, but  $\partial = 0.007/^\circ C$  can be used as an approximation for low voltage MOSFETs. Thus, if  $T_A = 85^\circ C$  and the available heat sinking has a thermal resistance of  $20^\circ C/W$ , the MOSFET junction temperature will be  $125^\circ C$  and  $\partial = 0.007(125 - 25) = 0.7$ . This means that the required  $R_{DS(ON)}$  of the MOSFET will be  $0.089\Omega/1.7 = 0.0523\Omega$ , which can be satisfied by an IRFZ34 manufactured by International Rectifier.

Transition losses result from the power dissipated in each MOSFET during the time it is transitioning from off to on, or from on to off. These losses are proportional to  $(f)(HV)^2$  and vary from insignificant to being a limiting factor on operating frequency in some high voltage applications.

## APPLICATIONS INFORMATION

### Paralleling MOSFETs

When the above calculations result in a lower  $R_{DS(ON)}$  than is economically feasible with a single MOSFET, two or more MOSFETs can be paralleled. The MOSFETs will inherently share the currents according to their  $R_{DS(ON)}$  ratio as long as they are thermally connected (e.g., on a common heat sink). The LT1336 top and bottom drivers can each drive five power MOSFETs in parallel with only a small loss in switching speeds (see Typical Performance Characteristics). A low value resistor ( $10\Omega$  to  $47\Omega$ ) in series with each individual MOSFET gate may be required to “decouple” each MOSFET from its neighbors to prevent high frequency oscillations (consult manufacturer’s recommendations). If gate decoupling resistors are used, the corresponding Gate Feedback pin can be connected to any one of the gates as shown in Figure 3.

Driving multiple MOSFETs in parallel may restrict the operating frequency to prevent overdissipation in the LT1336 (see the following Gate Charge and Driver Dissipation).

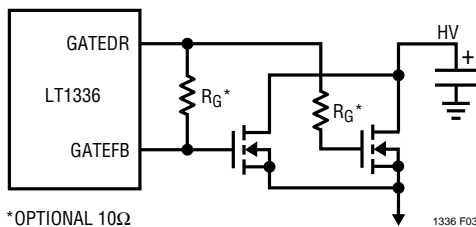

Figure 3. Paralleling MOSFETs

### Gate Charge and Driver Dissipation

A useful indicator of the load presented to the driver by a power MOSFET is the total gate charge  $Q_G$ , which includes the additional charge required by the gate-to-drain swing.  $Q_G$  is usually specified for  $V_{GS} = 10V$  and  $V_{DS} = 0.8V_{DS(MAX)}$ . When the supply current is measured in a switching application, it will be larger than given by the DC electrical characteristics because of the additional supply current associated with sourcing the MOSFET gate charge:

$$I_{SUPPLY} = I_{DC} + \left( \frac{dQ_G}{dt} \right)_{TOP} + \left( \frac{dQ_G}{dt} \right)_{BOTTOM}$$

The actual increase in supply current is slightly higher due to LT1336 switching losses and the fact that the gates are being charged to more than 10V. Supply Current vs Switching Frequency is given in the Typical Performance Characteristics.

The LT1336 junction temperature can be estimated by using the equations given in Note 1 of the Electrical Characteristics. For example, the LT1336IS is limited to less than 31mA from a 12V supply:

$$\begin{aligned} T_J &= 85^\circ C + (31mA)(12V)(110^\circ C/W) \\ &= 126^\circ C \text{ exceeds absolute maximum} \end{aligned}$$

In order to prevent the maximum junction temperature from being exceeded, the LT1336 supply current must be verified while driving the full complement of the chosen MOSFET type at the maximum switching frequency.

### Ugly Transient Issues

In PWM applications the drain current of the top MOSFET is a square wave at the input frequency and duty cycle. To prevent large voltage transients at the top drain, a low ESR electrolytic capacitor must be used and returned to the power ground. The capacitor is generally in the range of  $25\mu F$  to  $5000\mu F$  and must be physically sized for the RMS current flowing in the drain to prevent heating and premature failure. In addition, the LT1336 requires a separate  $10\mu F$  capacitor connected closely between Pins 2 and 6.

The LT1336 top source is internally protected against transients below ground and above supply. However, the Gate Drive pins cannot be forced below ground. In most applications, negative transients coupled from the source to the gate of the top MOSFET do not cause any problems.

### Switching Regulator Applications

The LT1336 is ideal as a synchronous switch driver to improve the efficiency of step-down (buck) switching regulators. Most step-down regulators use a high current Schottky diode to conduct the inductor current when the switch is off. The fractions of the oscillator period that the switch is on (switch conducting) and off (diode conducting) are given by:

## APPLICATIONS INFORMATION

$$\text{Switch On} = \left( \frac{V_{\text{OUT}}}{\text{HV}} \right) (\text{Total Period})$$

$$\text{Switch Off} = \left( \frac{\text{HV} - V_{\text{OUT}}}{\text{HV}} \right) (\text{Total Period})$$

Note that for  $\text{HV} > 2V_{\text{OUT}}$ , the switch is off longer than it is on, making the diode losses more significant than the switch. The worst case for the diode is during a short circuit, when  $V_{\text{OUT}}$  approaches zero and the diode conducts the short-circuit current almost continuously.

Figure 4 shows the LT1336 used to synchronously drive a pair of power MOSFETs in a step-down regulator application, where the top MOSFET is the switch and the bottom MOSFET replaces the Schottky diode. Since both conduction paths have low losses, this approach can result in very high efficiency (90% to 95%) in most applications. For regulators under 10A, using low  $R_{\text{DS(ON)}}$  N-channel MOSFETs eliminates the need for heat sinks.  $R_{\text{GS}}$  holds the top MOSFET off when HV is applied before the 12V supply.

One fundamental difference in the operation of a step-down regulator with synchronous switching is that it never becomes discontinuous at light loads. The inductor current doesn't stop ramping down when it reaches zero, but actually reverses polarity, resulting in a constant ripple current independent of load. This does not cause a significant efficiency loss (as might be expected) since the

negative inductor current is returned to HV when the switch turns back on. However,  $I^2R$  losses will occur under these conditions due to the recirculating currents.

The LT1336 performs the synchronous MOSFET drive in a step-down switching regulator. A reference and PWM are required to complete the regulator. Any voltage mode or current mode PWM controller may be used but the LT3526 is particularly well-suited to high power, high efficiency applications such as the 10A circuit shown in Figure 6. In higher current regulators a small Schottky diode across the bottom MOSFET helps to reduce reverse-recovery switching losses.

### Motor Drive Applications

In applications where rotation is always in the same direction, a single LT1336 controlling a half-bridge can be used to drive a DC motor. One end of the motor may be connected either to supply or to ground. A motor in this configuration is controlled by its inputs which give three alternatives: run, free running stop (coasting) and fast stop ("plugging" braking with the motor shorted by one of the MOSFETs).

Whenever possible, returning one end of the motor to ground is preferable. When the motor is returned to supply and the boost topology is used to charge the bootstrap capacitor, the return current from the top driver will find its way to the high voltage rail through the top MOSFET. Since

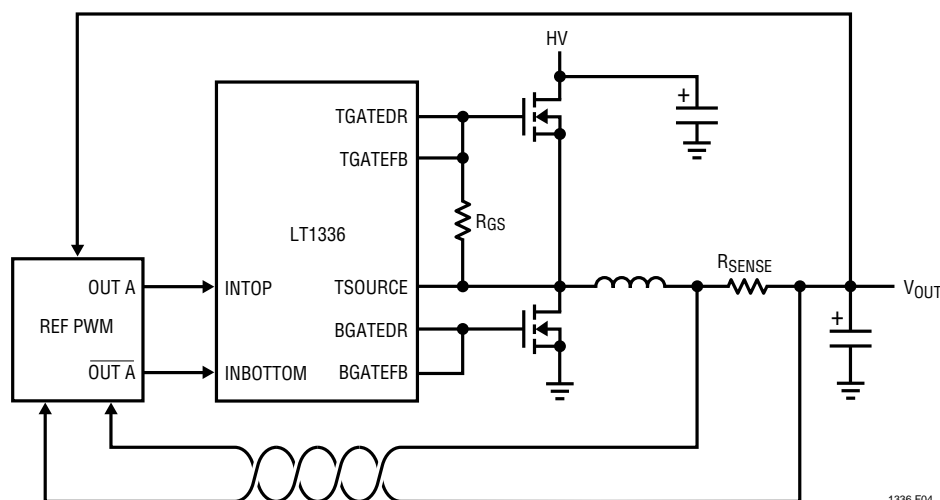

Figure 4. Adding Synchronous Switching to a Step-Down Switching Regulator

## APPLICATIONS INFORMATION

most power supplies cannot sink current, this current can raise the voltage of the high voltage rail. This can be avoided by placing a discharge resistor between HV supply and ground to divert the return current to ground as shown in Figure 5. For a high voltage rail of 40V, a 26k resistor or smaller should be used, since the top driver will return about 1.5mA.

For applications where using a discharge resistor is undesirable, use the flyback regulator topology instead of the boost regulator topology (see Deriving the Floating Supply with the Flyback Topology).

To drive a DC motor in both directions, two LT1336s can be used to drive an H-bridge output stage. In this configuration the motor can be made to run clockwise, counterclockwise, stop rapidly (“plugging” braking) or free run (coast) to a stop. A very rapid stop may be achieved by reversing the current, though this requires more careful design to stop the motor dead. In practice a closed-loop control system with tachometric feedback is usually necessary.

The motor speed in these examples can be controlled by switching the drivers with pulse width modulated square waves. This approach is particularly suitable for micro-computers/DSP control loops.

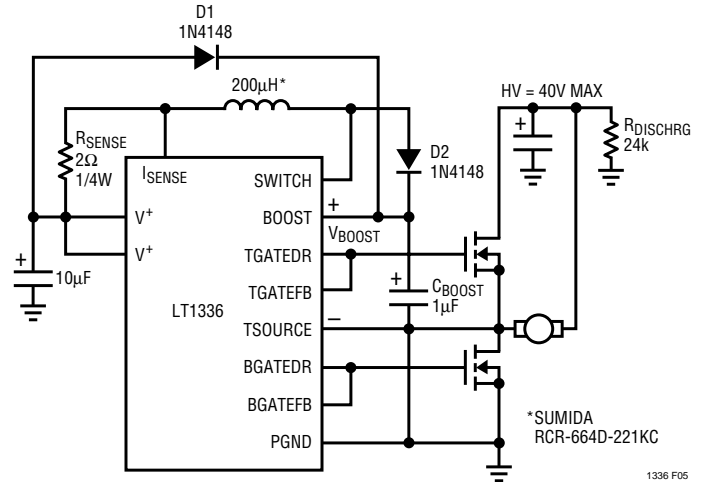
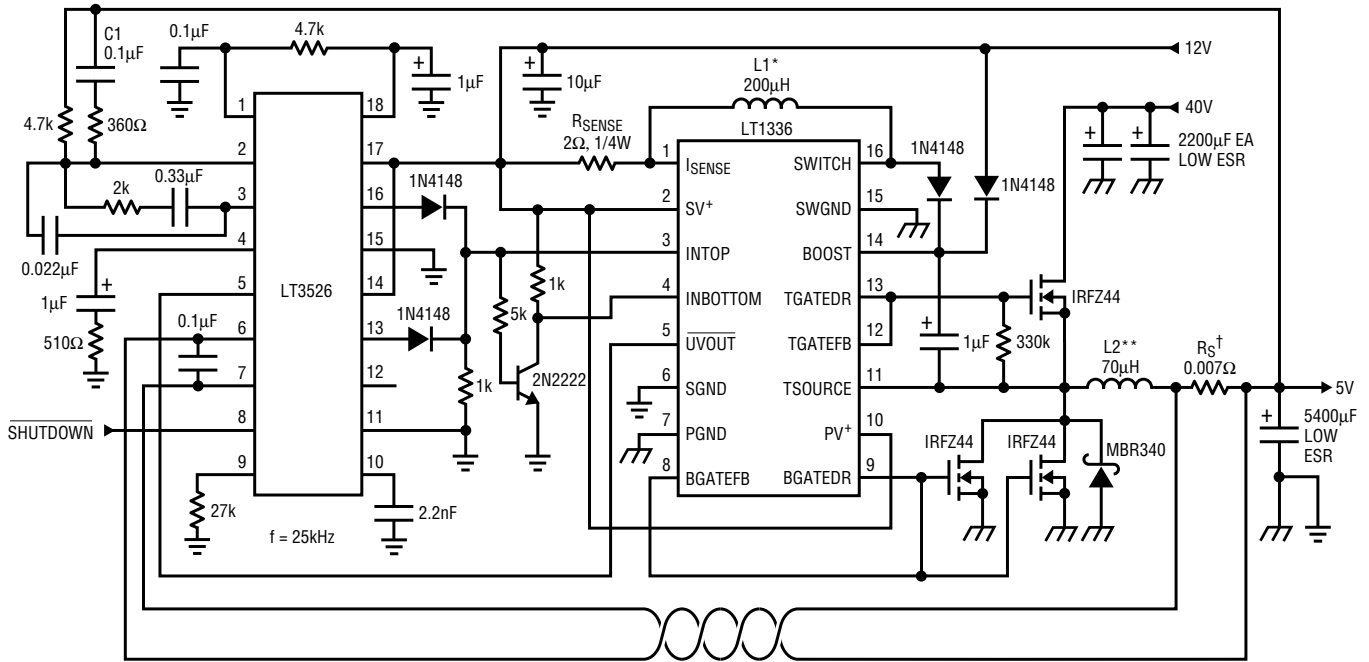

Figure 5. Driving a Supply Referenced Motor

## TYPICAL APPLICATIONS



\* SUMIDA RCR-664D-221KC  
 \*\* MAGNETICS CORE #55585-A2 30 TURNS 14GA MAGNET WIRE  
 † DALE TYPE LVR-3 ULTRONIX RCS01

Figure 6. 90% Efficiency, 40V to 5V, 10A, Low Dropout Voltage Mode Switching Regulator

# TYPICAL APPLICATIONS

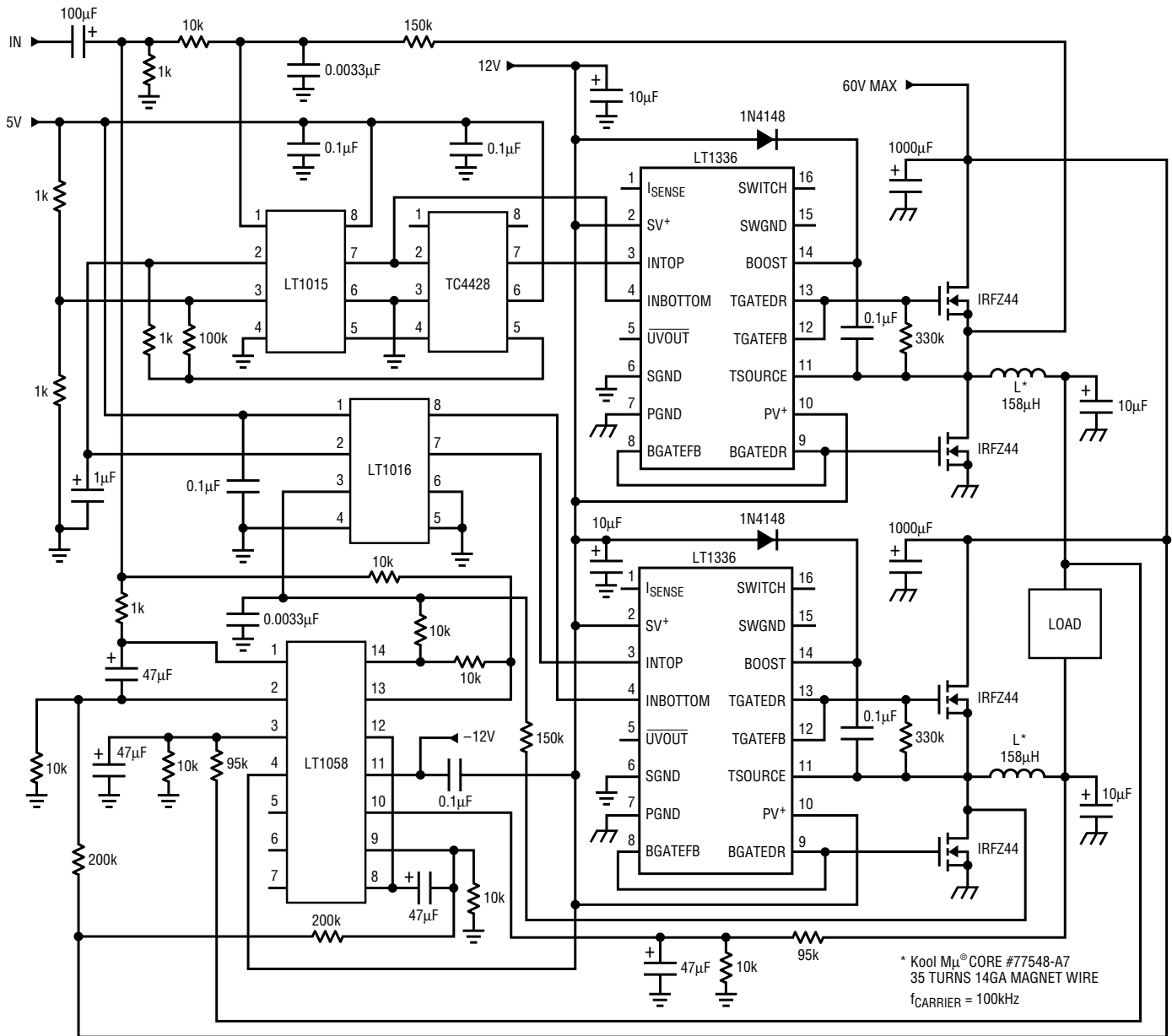
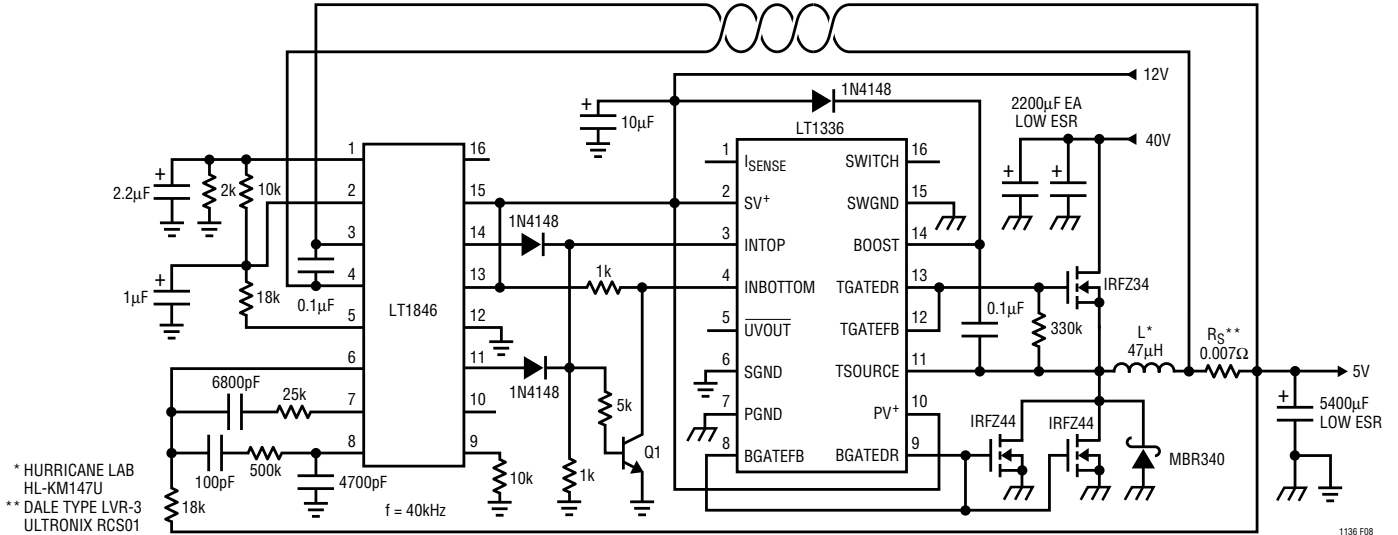

Figure 7. 200W Class D, 10Hz to 1kHz Amplifier

Kool M $\mu$  is a registered trademark of Magnetics, Inc.

**TYPICAL APPLICATIONS**



**Figure 8. 90% Efficiency, 40V to 5V, 10A, Low Dropout Current Mode Switching Regulator**

**PACKAGE DESCRIPTION** Dimensions in inches (millimeters) unless otherwise noted.

**N Package**  
**16-Lead PDIP (Narrow 0.300)**  
(LTC DWG # 05-08-1510)

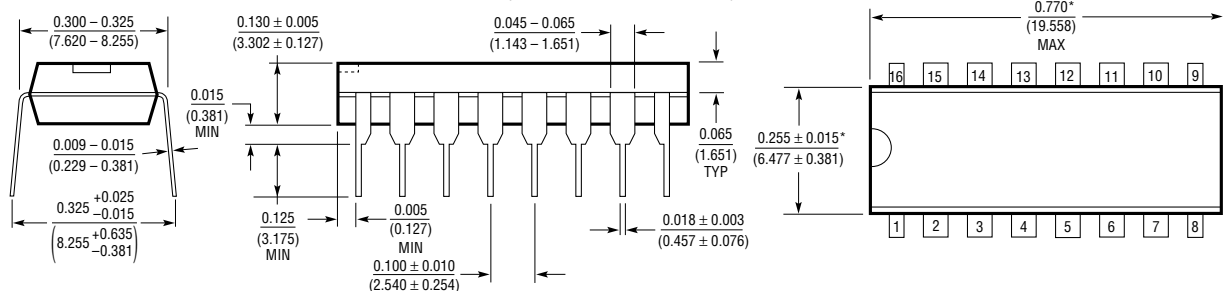

\*THESE DIMENSIONS DO NOT INCLUDE MOLD FLASH OR PROTRUSIONS.  
MOLD FLASH OR PROTRUSIONS SHALL NOT EXCEED 0.010 INCH (0.254mm)

**S Package**  
**16-Lead Plastic Small Outline (Narrow 0.150)**  
(LTC DWG # 05-08-1610)

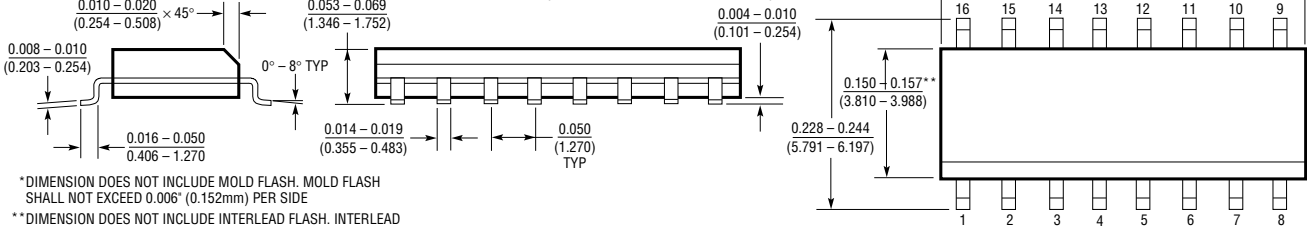

**RELATED PARTS**

PART NUMBER	DESCRIPTION	COMMENTS
LT1158	Half-Bridge N-Channel Power MOSFET Driver	Single Input, Continuous Current Protection and Internal Charge Pump for DC Operation
LT1160	Half-Bridge N-Channel Power MOSFET Driver	One Input per Channel, 60V High Voltage Supply Rail and Undervoltage Protection
LT1162	Full-Bridge N-Channel Power MOSFET Driver	One Input per Channel, 60V High Voltage Supply Rail and Undervoltage Protection