

Dual/Quad Low Noise, High Speed Precision Op Amps

FEATURES

- 100% Tested Low Voltage Noise: $2.7\text{nV}/\sqrt{\text{Hz}}$ Typ
 $4.2\text{nV}/\sqrt{\text{Hz}}$ Max
- Slew Rate: $4.5\text{V}/\mu\text{s}$ Typ
- Gain Bandwidth Product: 12.5MHz Typ
- Offset Voltage, Prime Grade: $70\mu\text{V}$ Max
Low Grade: $100\mu\text{V}$ Max
- High Voltage Gain: 5 Million Min
- Supply Current Per Amplifier: 2.75mA Max
- Common Mode Rejection: 112dB Min
- Power Supply Rejection: 116dB Min
- Available in 8-Pin SO Package

APPLICATIONS

- Two and Three Op Amp Instrumentation Amplifiers
- Low Noise Signal Processing
- Active Filters
- Microvolt Accuracy Threshold Detection
- Strain Gauge Amplifiers
- Direct Coupled Audio Gain Stages
- Tape Head Preamplifiers
- Infrared Detectors

LT, LTC and LT are registered trademarks of Linear Technology Corporation.
Protected by U.S. patents 4,775,884 and 4,837,496.

DESCRIPTION

The LT[®]1124 dual and LT1125 quad are high performance op amps that offer higher gain, slew rate and bandwidth than the industry standard OP-27 and competing OP-270/OP-470 op amps. In addition, the LT1124/LT1125 have lower I_B and I_{OS} than the OP-27; lower V_{OS} and noise than the OP-270/OP-470.

In the design, processing and testing of the device, particular attention has been paid to the optimization of the entire distribution of several key parameters. Slew rate, gain bandwidth and 1kHz noise are 100% tested for each individual amplifier. Consequently, the specifications of even the lowest cost grades (the LT1124C and the LT1125C) have been spectacularly improved compared to equivalent grades of competing amplifiers.

Power consumption of the LT1124 is one half of two OP-27s. Low power and high performance in an 8-pin SO package make the LT1124 a first choice for surface mounted systems and where board space is restricted.

For a decompensated version of these devices, with three times higher slew rate and bandwidth, please see the LT1126/LT1127 data sheet.

TYPICAL APPLICATION

Instrumentation Amplifier with Shield Driver

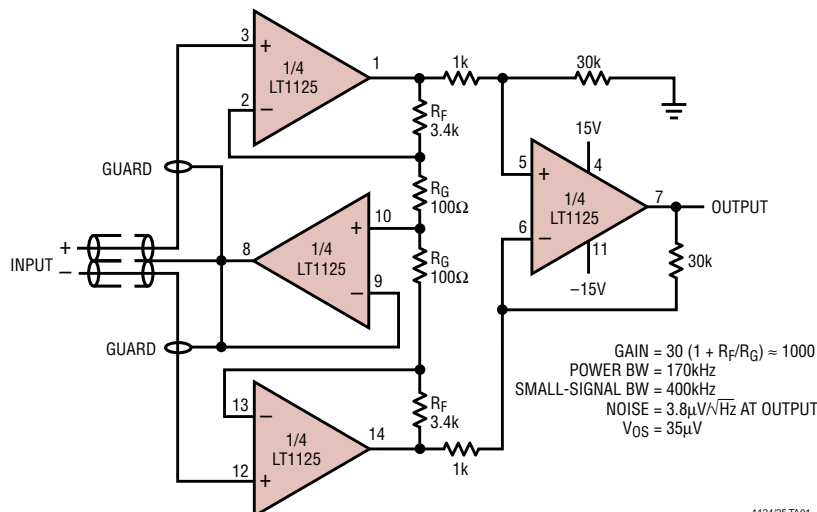

Input Offset Voltage Distribution
(All Packages, LT1124 and LT1125)

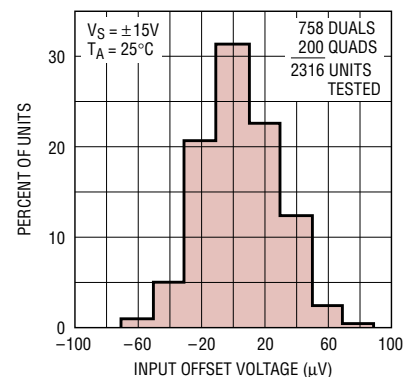

LT1124/LT1125

ABSOLUTE MAXIMUM RATINGS (Note 1)

Supply Voltage $\pm 22V$
 Input Voltages Equal to Supply Voltage
 Output Short-Circuit Duration Indefinite
 Differential Input Current (Note 6) $\pm 25mA$
 Lead Temperature (Soldering, 10 sec) $300^{\circ}C$
 Storage Temperature Range $-65^{\circ}C$ to $150^{\circ}C$

Operating Temperature Range
 LT1124AC/LT1124C
 LT1125AC/LT1125C (Note 10) $-40^{\circ}C$ to $85^{\circ}C$
 LT1124AI/LT1124I $-40^{\circ}C$ to $85^{\circ}C$
 LT1124AM/LT1124M
 LT1125AM/LT1125M $-55^{\circ}C$ to $125^{\circ}C$

PACKAGE/ORDER INFORMATION

<p>TOP VIEW</p> <p>S8 PACKAGE 8-LEAD PLASTIC SO</p> <p>$T_{JMAX} = 140^{\circ}C, \theta_{JA} = 190^{\circ}C$</p> <p>NOTE: THIS PIN CONFIGURATION DIFFERS FROM THE 8-PIN PDIP CONFIGURATION. INSTEAD, IT FOLLOWS THE INDUSTRY STANDARD LT1013DS8 SO PACKAGE PIN LOCATIONS</p>	<p>ORDER PART NUMBER</p> <p>LT1124CS8 LT1124AIS8 LT1124IS8</p> <p>S8 PART MARKING</p> <p>1124 1124AI 1124I</p>	<p>TOP VIEW</p> <p>J8 PACKAGE 8-LEAD CERDIP N8 PACKAGE 8-LEAD PDIP</p> <p>$T_{JMAX} = 160^{\circ}C, \theta_{JA} = 100^{\circ}C$ (J8) $T_{JMAX} = 140^{\circ}C, \theta_{JA} = 130^{\circ}C$ (N8)</p>	<p>ORDER PART NUMBER</p> <p>LT1124CJ8 LT1124ACN8 LT1124CN8 LT1124AMJ8 LT1124MJ8</p>
<p>TOP VIEW</p> <p>SW PACKAGE 16-LEAD PLASTIC (WIDE) SO</p> <p>$T_{JMAX} = 140^{\circ}C, \theta_{JA} = 130^{\circ}C$</p>	<p>LT1125CS</p>	<p>TOP VIEW</p> <p>J PACKAGE 14-LEAD CERDIP N PACKAGE 14-LEAD PDIP</p> <p>$T_{JMAX} = 160^{\circ}C, \theta_{JA} = 80^{\circ}C$ (J) $T_{JMAX} = 140^{\circ}C, \theta_{JA} = 110^{\circ}C$ (N)</p>	<p>LT1125CJ LT1125ACN LT1125CN LT1125AMJ LT1125MJ</p>

ELECTRICAL CHARACTERISTICS $T_A = 25^{\circ}C, V_S = \pm 15V$, unless otherwise noted.

SYMBOL	PARAMETER	CONDITIONS (Note 2)	LT1124AC/AI/AM LT1125AC/AM			LT1124C/I/M LT1125C/M			UNITS
			MIN	TYP	MAX	MIN	TYP	MAX	
V_{OS}	Input Offset Voltage	LT1124 LT1125		20 25	70 90		25 30	100 140	μV μV
$\frac{\Delta V_{OS}}{\Delta Time}$	Long Term Input Offset Voltage Stability			0.3			0.3		$\mu V/Mo$
I_{OS}	Input Offset Current	LT1124 LT1125		5 6	15 20		6 7	20 30	nA nA

ELECTRICAL CHARACTERISTICS $T_A = 25^\circ\text{C}$, $V_S = \pm 15\text{V}$, unless otherwise noted.

SYMBOL	PARAMETER	CONDITIONS (Note 2)	LT1124AC/AI/AM LT1125AC/AM			LT1124C/I/M LT1125C/M			UNITS
			MIN	TYP	MAX	MIN	TYP	MAX	
I_B	Input Bias Current			± 7	± 20		± 8	± 30	nA
e_n	Input Noise Voltage	0.1Hz to 10Hz (Notes 8, 9)		70	200		70		nV _{p-p}
	Input Noise Voltage Density	$f_0 = 10\text{Hz}$ (Note 4) $f_0 = 1000\text{Hz}$ (Note 3)		3.0 2.7	5.5 4.2		3.0 2.7	5.5 4.2	$\text{nV}/\sqrt{\text{Hz}}$ $\text{nV}/\sqrt{\text{Hz}}$
i_n	Input Noise Current Density	$f_0 = 10\text{Hz}$ $f_0 = 1000\text{Hz}$		1.3 0.3			1.3 0.3		$\text{pA}/\sqrt{\text{Hz}}$ $\text{pA}/\sqrt{\text{Hz}}$
V_{CM}	Input Voltage Range		± 12	± 12.8		± 12	± 12.8		V
CMRR	Common Mode Rejection Ratio	$V_{CM} = \pm 12\text{V}$	112	126		106	124		dB
PSRR	Power Supply Rejection Ratio	$V_S = \pm 4\text{V}$ to $\pm 18\text{V}$	116	126		110	124		dB
A_{VOL}	Large-Signal Voltage Gain	$R_L \geq 10\text{k}$, $V_{OUT} = \pm 10\text{V}$ $R_L \geq 2\text{k}$, $V_{OUT} = \pm 10\text{V}$	5 2	17 4		3.0 1.5	15 3		$\text{V}/\mu\text{V}$ $\text{V}/\mu\text{V}$
V_{OUT}	Maximum Output Voltage Swing	$R_L \geq 2\text{k}$	± 13	± 13.8		± 12.5	± 13.8		V
SR	Slew Rate	$R_L \geq 2\text{k}$ (Notes 3, 7)	3	4.5		2.7	4.5		$\text{V}/\mu\text{s}$
GBW	Gain Bandwidth Product	$f_0 = 100\text{kHz}$ (Note 3)	9	12.5		8	12.5		MHz
Z_O	Open-Loop Output Resistance	$V_{OUT} = 0$, $I_{OUT} = 0$		75			75		Ω
I_S	Supply Current per Amplifier			2.3	2.75		2.3	2.75	mA
	Channel Separation	$f \leq 10\text{Hz}$ (Note 9) $V_{OUT} = \pm 10\text{V}$, $R_L = 2\text{k}$	134	150		130	150		dB

The ● denotes the specifications which apply over the $-55^\circ\text{C} \leq T_A \leq 125^\circ\text{C}$ temperature range, $V_S = \pm 15\text{V}$, unless otherwise noted.

SYMBOL	PARAMETER	CONDITIONS (Note 2)		LT1124AM LT1125AM			LT1124M LT1125M			UNITS
				MIN	TYP	MAX	MIN	TYP	MAX	
V_{OS}	Input Offset Voltage	LT1124	●	50	170		60	250	μV	
		LT1125	●	55	190		70	290	μV	
$\frac{\Delta V_{OS}}{\Delta \text{Temp}}$	Average Input Offset Voltage Drift	(Note 5)	●	0.3	1.0		0.4	1.5	$\mu\text{V}/^\circ\text{C}$	
I_{OS}	Input Offset Current	LT1124	●	18	45		20	60	nA	
		LT1125	●	18	55		20	70	nA	
I_B	Input Bias Current		●	± 18	± 55		± 20	± 70	nA	
V_{CM}	Input Voltage Range		●	± 11.3	± 12		± 11.3	± 12	V	
CMRR	Common Mode Rejection Ratio	$V_{CM} = \pm 11.3\text{V}$	●	106	122		100	120	dB	
PSRR	Power Supply Rejection Ratio	$V_S = \pm 4\text{V}$ to $\pm 18\text{V}$	●	110	122		104	120	dB	
A_{VOL}	Large-Signal Voltage Gain	$R_L \geq 10\text{k}$, $V_{OUT} = \pm 10\text{V}$ $R_L \geq 2\text{k}$, $V_{OUT} = \pm 10\text{V}$	● ●	3 1	10 3		2.0 0.7	10 2	$\text{V}/\mu\text{V}$ $\text{V}/\mu\text{V}$	
V_{OUT}	Maximum Output Voltage Swing	$R_L \geq 2\text{k}$	●	± 12.5	± 13.6		± 12	± 13.6	V	
SR	Slew Rate	$R_L \geq 2\text{k}$ (Notes 3, 7)	●	2.3	3.8		2	3.8	$\text{V}/\mu\text{s}$	
I_S	Supply Current per Amplifier		●	2.5	3.25		2.5	3.25	mA	

LT1124/LT1125

ELECTRICAL CHARACTERISTICS

The ● denotes the specifications which apply over the $0^{\circ}\text{C} \leq T_A \leq 70^{\circ}\text{C}$ temperature range, $V_S = \pm 15\text{V}$, unless otherwise noted.

SYMBOL	PARAMETER	CONDITIONS (Note 2)		LT1124AC LT1125AC			LT1124C LT1125C			UNITS
				MIN	TYP	MAX	MIN	TYP	MAX	
V_{OS}	Input Offset Voltage	LT1124 LT1125	● ●		35	120		45	170	μV
					40	140		50	210	μV
$\frac{\Delta V_{OS}}{\Delta \text{Temp}}$	Average Input Offset Voltage Drift	(Note 5)	●		0.3	1		0.4	1.5	$\mu\text{V}/^{\circ}\text{C}$
I_{OS}	Input Offset Current	LT1124 LT1125	● ●		6	25		7	35	nA
					7	35		8	45	nA
I_B	Input Bias Current		●		± 8	± 35		± 9	± 45	nA
V_{CM}	Input Voltage Range		●	± 11.5	± 12.4		± 11.5	± 12.4		V
CMRR	Common Mode Rejection Ratio	$V_{CM} = \pm 11.5\text{V}$	●	109	125		102	122		dB
PSRR	Power Supply Rejection Ratio	$V_S = \pm 4\text{V}$ to $\pm 18\text{V}$	●	112	125		107	122		dB
A_{VOL}	Large-Signal Voltage Gain	$R_L \geq 10\text{k}$, $V_{OUT} = \pm 10\text{V}$ $R_L \geq 2\text{k}$, $V_{OUT} = \pm 10\text{V}$	● ●		4.0	15		2.5	14	$\text{V}/\mu\text{V}$
					1.5	3.5		1.0	2.5	$\text{V}/\mu\text{V}$
V_{OUT}	Maximum Output Voltage Swing	$R_L \geq 2\text{k}$	●	± 12.5	± 13.7		± 12	± 13.7		V
SR	Slew Rate	$R_L \geq 2\text{k}$ (Notes 3, 7)	●	2.6	4		2.4	4		$\text{V}/\mu\text{s}$
I_S	Supply Current per Amplifier		●		2.4	3		2.4	3	mA

The ● denotes the specifications which apply over the $-40^{\circ}\text{C} \leq T_A \leq 85^{\circ}\text{C}$ temperature range, $V_S = \pm 15\text{V}$, unless otherwise noted. (Note 10)

SYMBOL	PARAMETER	CONDITIONS (Note 2)		LT1124AC/AI LT1125AC			LT1124C/I LT1125C			UNITS
				MIN	TYP	MAX	MIN	TYP	MAX	
V_{OS}	Input Offset Voltage	LT1124 LT1125	● ●		40	140		50	200	μV
					45	160		55	240	μV
$\frac{\Delta V_{OS}}{\Delta \text{Temp}}$	Average Input Offset Voltage Drift	(Note 5)	●		0.3	1		0.4	1.5	$\mu\text{V}/^{\circ}\text{C}$
I_{OS}	Input Offset Current	LT1124 LT1125	● ●		15	40		17	55	nA
					15	50		17	65	nA
I_B	Input Bias Current		●		± 15	± 50		± 17	± 65	nA
V_{CM}	Input Voltage Range		●	± 11.4	± 12.2		± 11.4	± 12.2		V
CMRR	Common Mode Rejection Ratio	$V_{CM} = \pm 11.4\text{V}$	●	107	124		101	121		dB
PSRR	Power Supply Rejection Ratio	$V_S = \pm 4\text{V}$ to $\pm 18\text{V}$	●	111	124		106	121		dB
A_{VOL}	Large-Signal Voltage Gain	$R_L \geq 10\text{k}$, $V_{OUT} = \pm 10\text{V}$ $R_L \geq 2\text{k}$, $V_{OUT} = \pm 10\text{V}$	● ●		3.5	12		2.2	12	$\text{V}/\mu\text{V}$
					1.2	3.2		0.8	2.3	$\text{V}/\mu\text{V}$
V_{OUT}	Maximum Output Voltage Swing	$R_L \geq 2\text{k}$	●	± 12.5	± 13.6		± 12	± 13.6		V
SR	Slew Rate	$R_L \geq 2\text{k}$ (Notes 3, 7)	●	2.4	3.9		2.1	3.9		$\text{V}/\mu\text{s}$
I_S	Supply Current per Amplifier		●		2.4	3.25		2.4	3.25	mA

Note 1: Absolute Maximum Ratings are those values beyond which the life of a device may be impaired.

Note 2: Typical parameters are defined as the 60% yield of parameter distributions of individual amplifiers; i.e., out of 100 LT1125s (or 100 LT1124s) typically 240 op amps (or 120) will be better than the indicated specification.

Note 3: This parameter is 100% tested for each individual amplifier.

Note 4: This parameter is sample tested only.

Note 5: This parameter is not 100% tested.

Note 6: The inputs are protected by back-to-back diodes. Current limiting resistors are not used in order to achieve low noise. If differential input voltage exceeds $\pm 1.4\text{V}$, the input current should be limited to 25mA.

Note 7: Slew rate is measured in $A_V = -1$; input signal is $\pm 7.5\text{V}$, output measured at $\pm 2.5\text{V}$.

Note 8: 0.1Hz to 10Hz noise can be inferred from the 10Hz noise voltage density test. See the test circuit and frequency response curve for 0.1Hz to 10Hz tester in the Applications Information section of the LT1007 or LT1028 data sheets.

Note 9: This parameter is guaranteed but not tested.

Note 10: The LT1124C/LT1125C and LT1124AC/LT1125AC are guaranteed to meet specified performance from 0°C to 70°C and are designed, characterized and expected to meet these extended temperature limits, but are not tested at -40°C and 85°C . The LT1124AI and LT1124I are guaranteed to meet the extended temperature limits.

TYPICAL PERFORMANCE CHARACTERISTICS

0.1Hz to 10Hz Voltage Noise

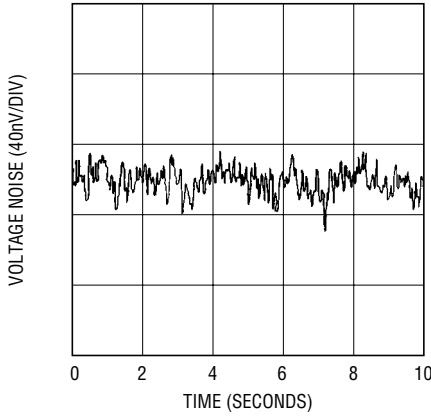

1124/25 G01

0.01Hz to 1Hz Voltage Noise

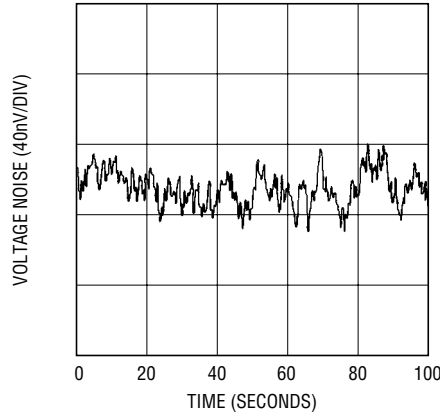

1124/25 G02

Voltage Noise vs Frequency

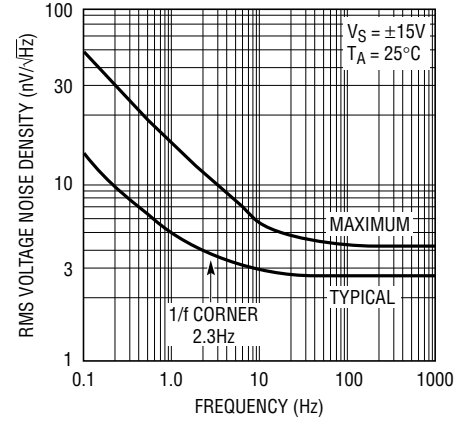

1124/25 G03

Current Noise vs Frequency

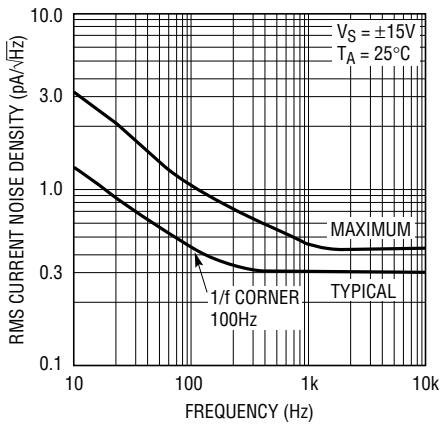

1124 G04

Input Bias or Offset Current vs Temperature

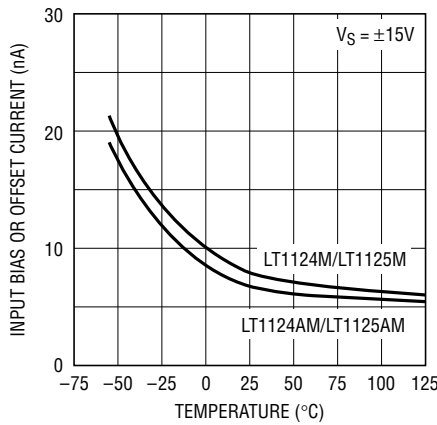

1124/25 G05

Output Short-Circuit Current vs Time

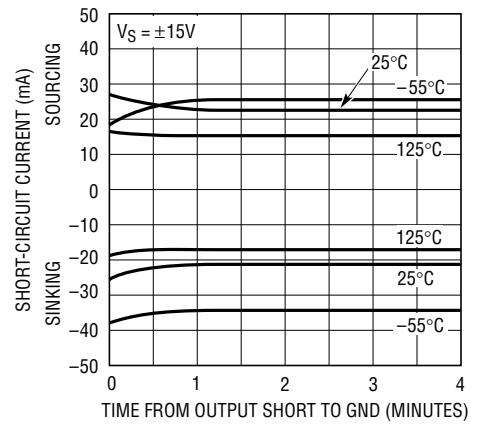

LT1124 G06

Input Bias Current Over the Common Mode Range

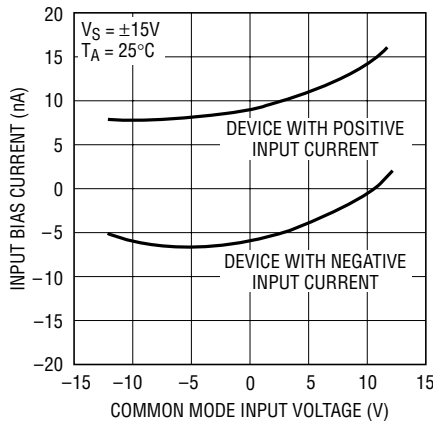

1124/25 G07

Common Mode Rejection Ratio vs Frequency

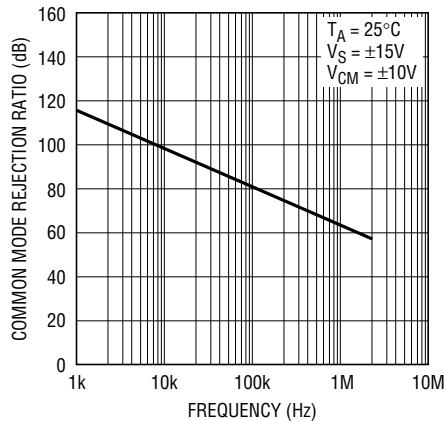

1124/25 G08

Power Supply Rejection Ratio vs Frequency

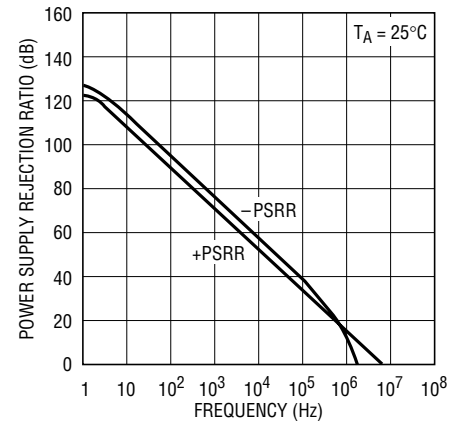

1124/25 G09

TYPICAL PERFORMANCE CHARACTERISTICS

Voltage Gain vs Frequency

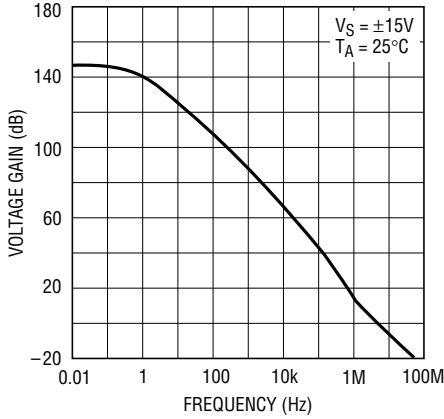

1124/25 G10

Voltage Gain vs Temperature

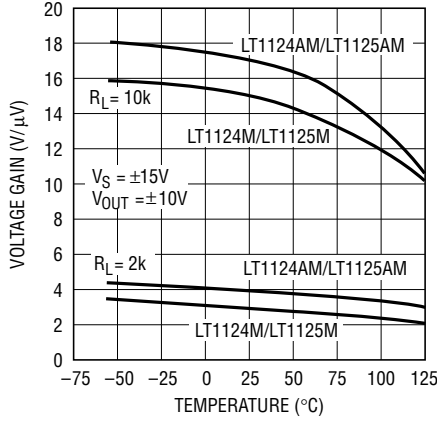

1124/25 G11

Gain, Phase Shift vs Frequency

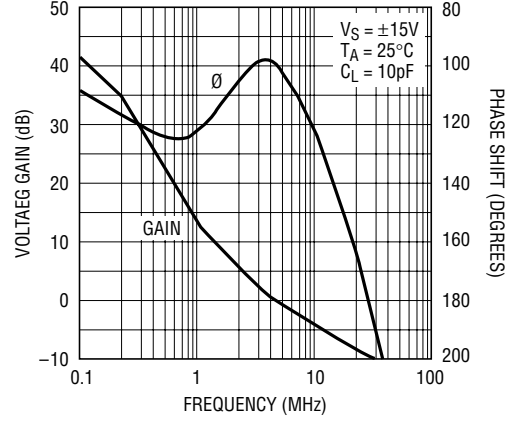

1124/25 G12

Input Offset Voltage Drift Distribution

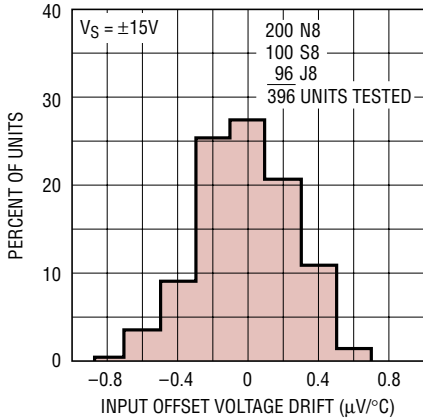

1124/25 G13

Offset Voltage Drift with Temperature of Representative Units

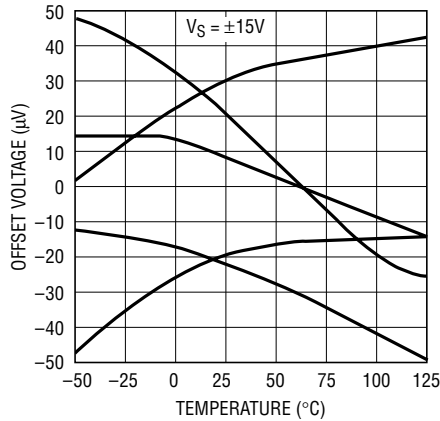

1124/25 G14

Supply Current vs Supply Voltage

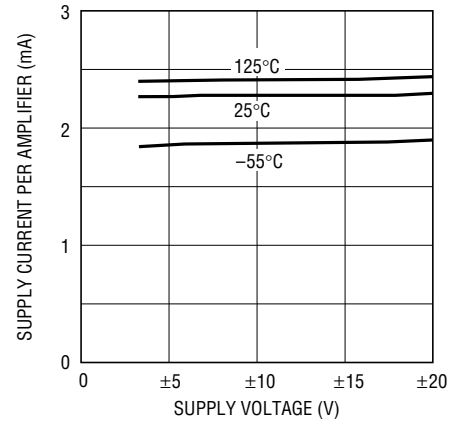

1124/25 G15

Small-Signal Transient Response

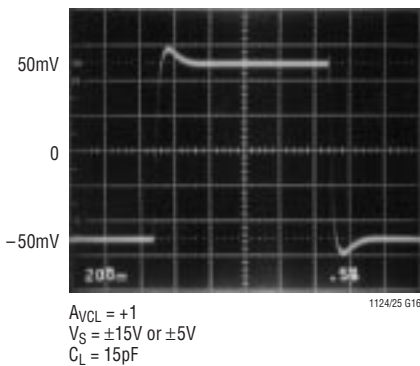

1124/25 G16

Large-Signal Transient Response

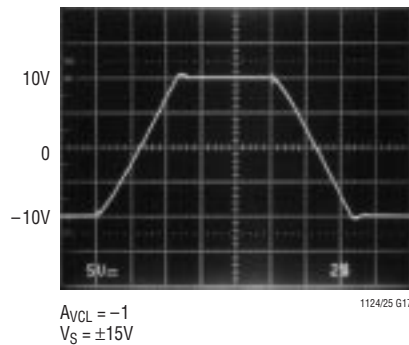

1124/25 G17

Output Voltage Swing vs Load Current

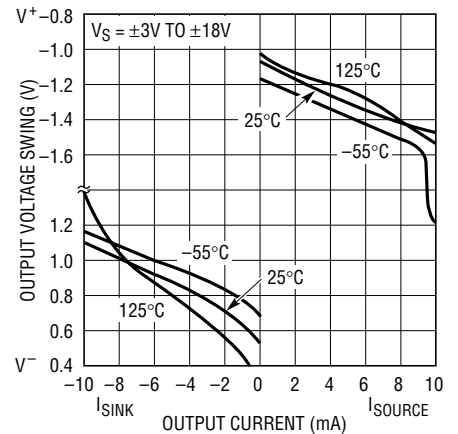

1124/25 G18

TYPICAL PERFORMANCE CHARACTERISTICS

Common Mode Limit vs Temperature

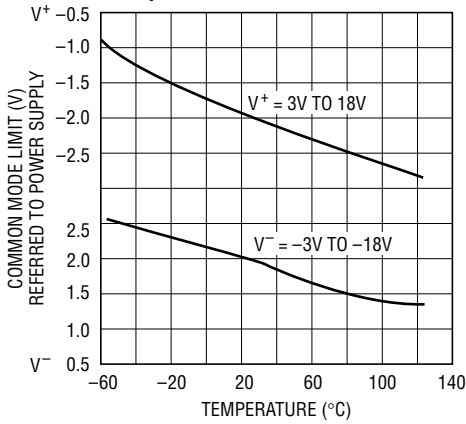

1124/25 G19

Channel Separation vs Frequency

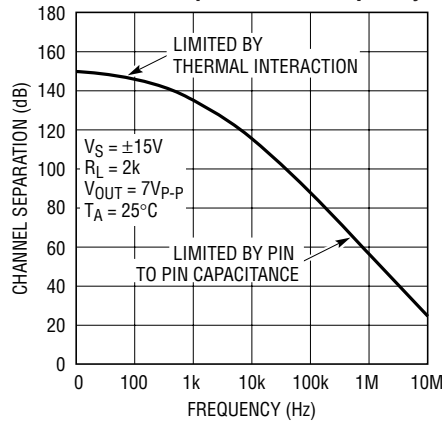

1124/25 G20

Warm-Up Drift

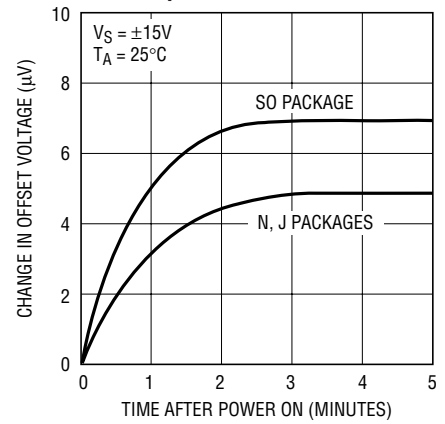

1124/25 G21

Total Harmonic Distortion and Noise vs Frequency for Noninverting Gain

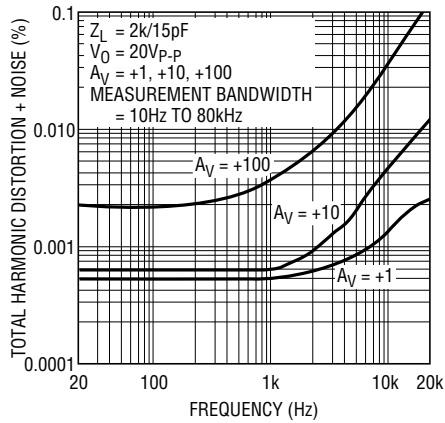

1124/25 G22

Total Harmonic Distortion and Noise vs Frequency for Inverting Gain

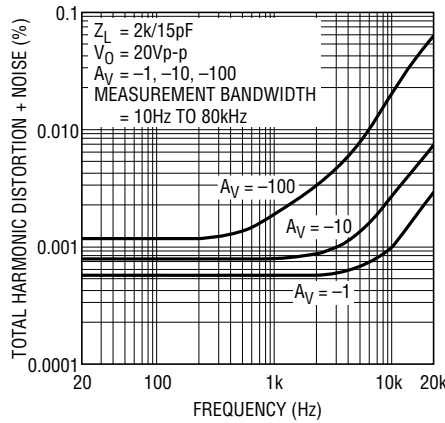

1124/25 G23

Total Harmonic Distortion and Noise vs Frequency for Competitive Devices

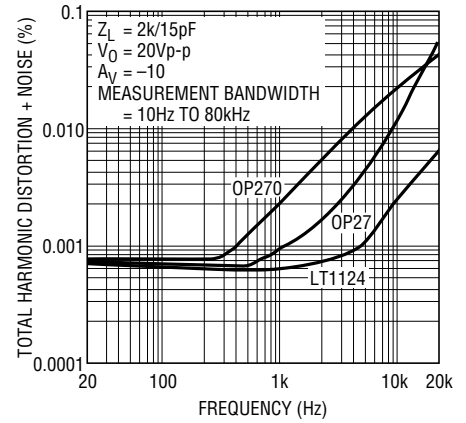

1124/25 G24

Total Harmonic Distortion and Noise vs Output Amplitude for Noninverting Gain

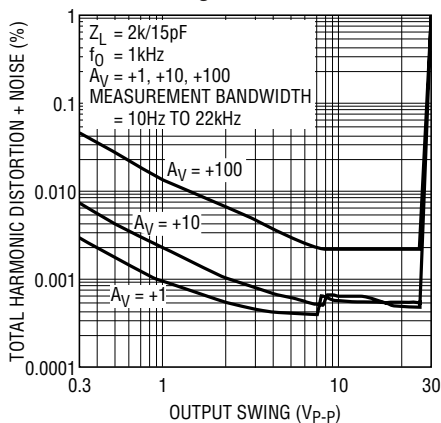

1124/25 G25

Total Harmonic Distortion and Noise vs Output Amplitude for Inverting Gain

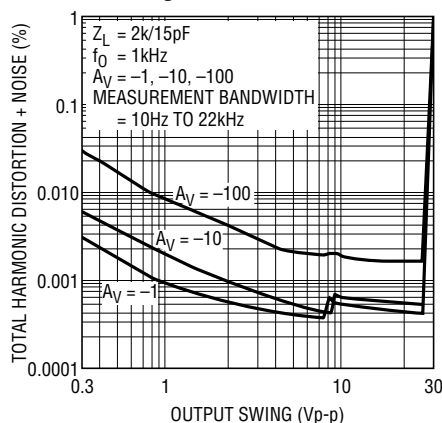

1124/25 G26

Intermodulation Distortion (CCIF Method)* vs Frequency LT1124 and OP270

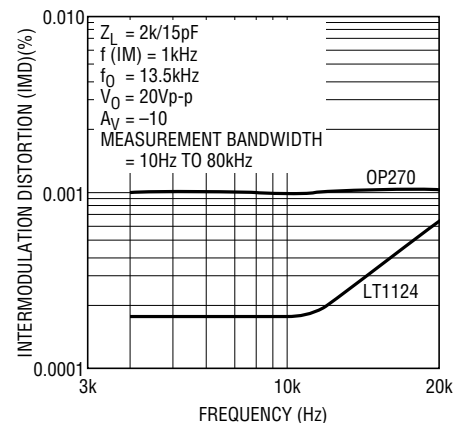

1124/25 G27

*See LT1115 data sheet for definition of CCIF testing

APPLICATIONS INFORMATION

The LT1124 may be inserted directly into OP-270 sockets. The LT1125 plugs into OP-470 sockets. Of course, all standard dual and quad bipolar op amps can also be replaced by these devices.

Matching Specifications

In many applications the performance of a system depends on the matching between two op amps, rather than the individual characteristics of the two devices. The three op amp instrumentation amplifier configuration shown in this data sheet is an example. Matching characteristics are not 100% tested on the LT1124/LT1125.

Some specifications are guaranteed by definition. For example, 70 μ V maximum offset voltage implies that mismatch cannot be more than 140 μ V. 112dB (= 2.5 μ V/V) CMRR means that worst case CMRR match is 106dB

(5 μ V/V). However, Table 1 can be used to estimate the expected matching performance between the two sides of the LT1124, and between amplifiers A and D, and between amplifiers B and C of the LT1125.

Offset Voltage and Drift

Thermocouple effects, caused by temperature gradients across dissimilar metals at the contacts to the input terminals, can exceed the inherent drift of the amplifier unless proper care is exercised. Air currents should be minimized, package leads should be short, the two input leads should be close together and maintained at the same temperature.

The circuit shown in Figure 1 to measure offset voltage is also used as the burn-in configuration for the LT1124/LT1125, with the supply voltages increased to ± 16 V.

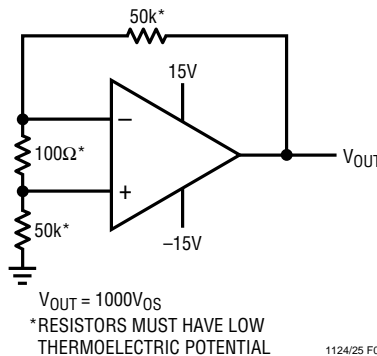

Figure 1. Test Circuit for Offset Voltage and Offset Voltage Drift with Temperature

Table 1. Expected Match

PARAMETER		LT1124AC/AM LT1125AC/AM		LT1124C/M LT1125C/M		UNITS
		50% YIELD	98% YIELD	50% YIELD	98% YIELD	
V_{OS} Match, ΔV_{OS}	LT1124	20	110	30	130	μ V
	LT1125	30	150	50	180	μ V
Temperature Coefficient Match		0.35	1.0	0.5	1.5	μ V/ $^{\circ}$ C
Average Noninverting I_B		6	18	7	25	nA
Match of Noninverting I_B		7	22	8	30	nA
CMRR Match		126	115	123	112	dB
PSRR Match		127	118	127	114	dB

APPLICATIONS INFORMATION

High Speed Operation

When the feedback around the op amp is resistive (R_F), a pole will be created with R_F , the source resistance and capacitance (R_S , C_S), and the amplifier input capacitance ($C_{IN} \approx 2\text{pF}$). In low closed loop gain configurations and with R_S and R_F in the kilohm range, this pole can create excess phase shift and even oscillation. A small capacitor (C_F) in parallel with R_F eliminates this problem (see Figure 2). With $R_S (C_S + C_{IN}) = R_F C_F$, the effect of the feedback pole is completely removed.

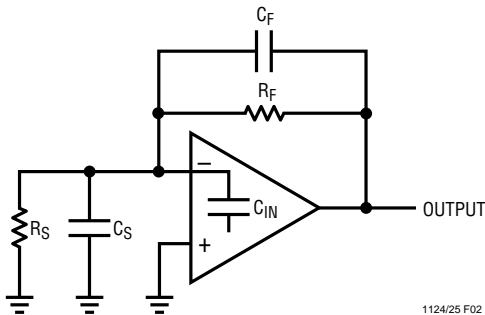

Figure 2. High Speed Operation

Unity Gain Buffer Applications

When $R_F \leq 100\Omega$ and the input is driven with a fast, large signal pulse ($>1\text{V}$), the output waveform will look as shown in Figure 3.

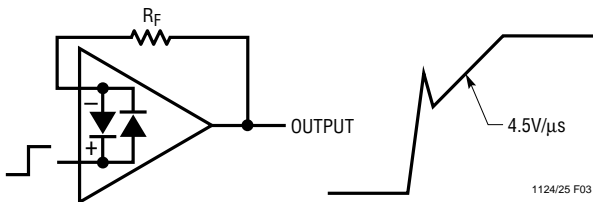

Figure 3. Unity-Gain Buffer Applications

During the fast feedthrough-like portion of the output, the input protection diodes effectively short the output to the input and a current, limited only by the output short circuit protection, will be drawn by the signal generator. With $R_F \geq 500\Omega$, the output is capable of handling the current requirements ($I_L \leq 20\text{mA}$ at 10V) and the amplifier stays in its active mode and a smooth transition will occur.

Noise Testing

Each individual amplifier is tested to $4.2\text{nV}/\sqrt{\text{Hz}}$ voltage noise; i.e., for the LT1124 two tests, for the LT1125 four tests are performed. Noise testing for competing multiple op amps, if done at all, may be sample tested or tested using the circuit shown in Figure 4.

$$e_{n \text{ OUT}} = \sqrt{(e_{nA})^2 + (e_{nB})^2 + (e_{nC})^2 + (e_{nD})^2}$$

If the LT1125 were tested this way, the noise limit would be $\sqrt{4 \cdot (4.2\text{nV}/\sqrt{\text{Hz}})^2} = 8.4\text{nV}/\sqrt{\text{Hz}}$. But is this an effective screen? What if three of the four amplifiers are at a typical $2.7\text{nV}/\sqrt{\text{Hz}}$, and the fourth one was contaminated and has $6.9\text{nV}/\sqrt{\text{Hz}}$ noise?

$$\text{RMS Sum} = \sqrt{(2.7)^2 + (2.7)^2 + (2.7)^2 + (6.9)^2} = 8.33\text{nV}/\sqrt{\text{Hz}}$$

This passes an $8.4\text{nV}/\sqrt{\text{Hz}}$ spec, yet one of the amplifiers is 64% over the LT1125 spec limit. Clearly, for proper noise measurement, the op amps have to be tested individually.

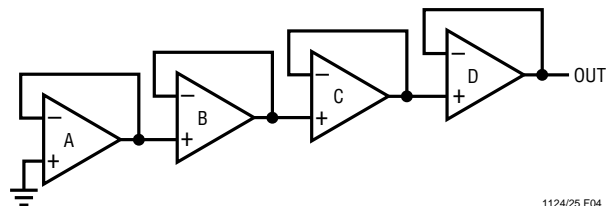

Figure 4. Competing Quad Op Amp Noise Test Method

PERFORMANCE COMPARISON

Table 2 summarizes the performance of the LT1124/LT1125 compared to the low cost grades of alternate approaches.

but in most cases are superior. Normally dual and quad performance is degraded when compared to singles, for the LT1124/LT1125 this is not the case.

The comparison shows how the specs of the LT1124/LT1125 not only stand up to the industry standard OP-27,

Table 2. Guaranteed Performance, $V_S = \pm 15V$, $T_A = 25^\circ C$, Low Cost Devices

PARAMETER/UNITS		LT1124CN8 LT1125CN	OP-27 GP	OP-270 GP	OP-470 GP	UNITS
Voltage Noise, 1kHz		4.2 100% Tested	4.5 Sample Tested	– No Limit	5.0 Sample Tested	nV/\sqrt{Hz}
Slew Rate		2.7 100% Tested	1.7 Not Tested	1.7	1.4	$V/\mu s$
Gain Bandwidth Product		8.0 100% Tested	5.0 Not Tested	– No Limit	– No Limit	MHz
Offset Voltage	LT1124	100	100	250	–	μV
	LT1125	140	–	–	1000	μV
Offset Current	LT1124	20	75	20	–	nA
	LT1125	30	–	–	30	nA
Bias Current		30	80	60	60	nA
Supply Current/Amp		2.75	5.67	3.25	2.75	mA
Voltage Gain, $R_L = 2k$		1.5	0.7	0.35	0.4	$V/\mu V$
Common Mode Rejection Ratio		106	100	90	100	dB
Power Supply Rejection Ratio		110	94	104	105	dB
SO-8 Package		Yes - LT1124	Yes	No	–	

TYPICAL APPLICATIONS

Gain 1000 Amplifier with 0.01% Accuracy, DC to 1Hz

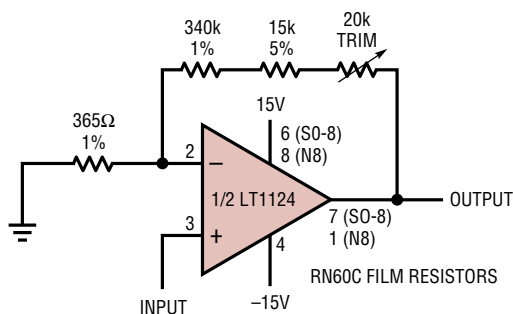

THE HIGH GAIN AND WIDE BANDWIDTH OF THE LT1124/LT1125, IS USEFUL IN LOW FREQUENCY HIGH CLOSED-LOOP GAIN AMPLIFIER APPLICATIONS. A TYPICAL PRECISION OP AMP MAY HAVE AN OPEN-LOOP GAIN OF ONE MILLION WITH 500kHz BANDWIDTH. AS THE GAIN ERROR PLOT SHOWS, THIS DEVICE IS CAPABLE OF 0.1% AMPLIFYING ACCURACY UP TO 0.3Hz ONLY. EVEN INSTRUMENTATION RANGE SIGNALS CAN VARY AT A FASTER RATE. THE LT1124/LT1125 "GAIN PRECISION — BANDWIDTH PRODUCT" IS 75 TIMES HIGHER, AS SHOWN.

1124/25 TA03

Gain Error vs Frequency Closed-Loop Gain = 1000

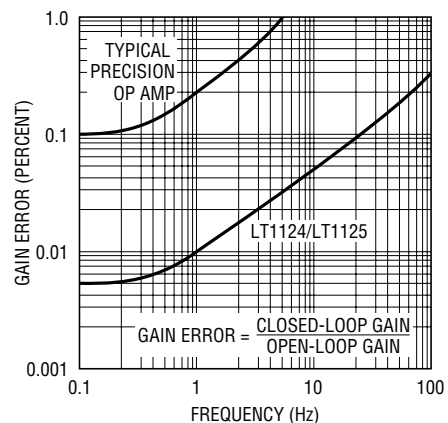

1124/25 TA04

SCHEMATIC DIAGRAM (1/2 LT1124, 1/4 LT1125)

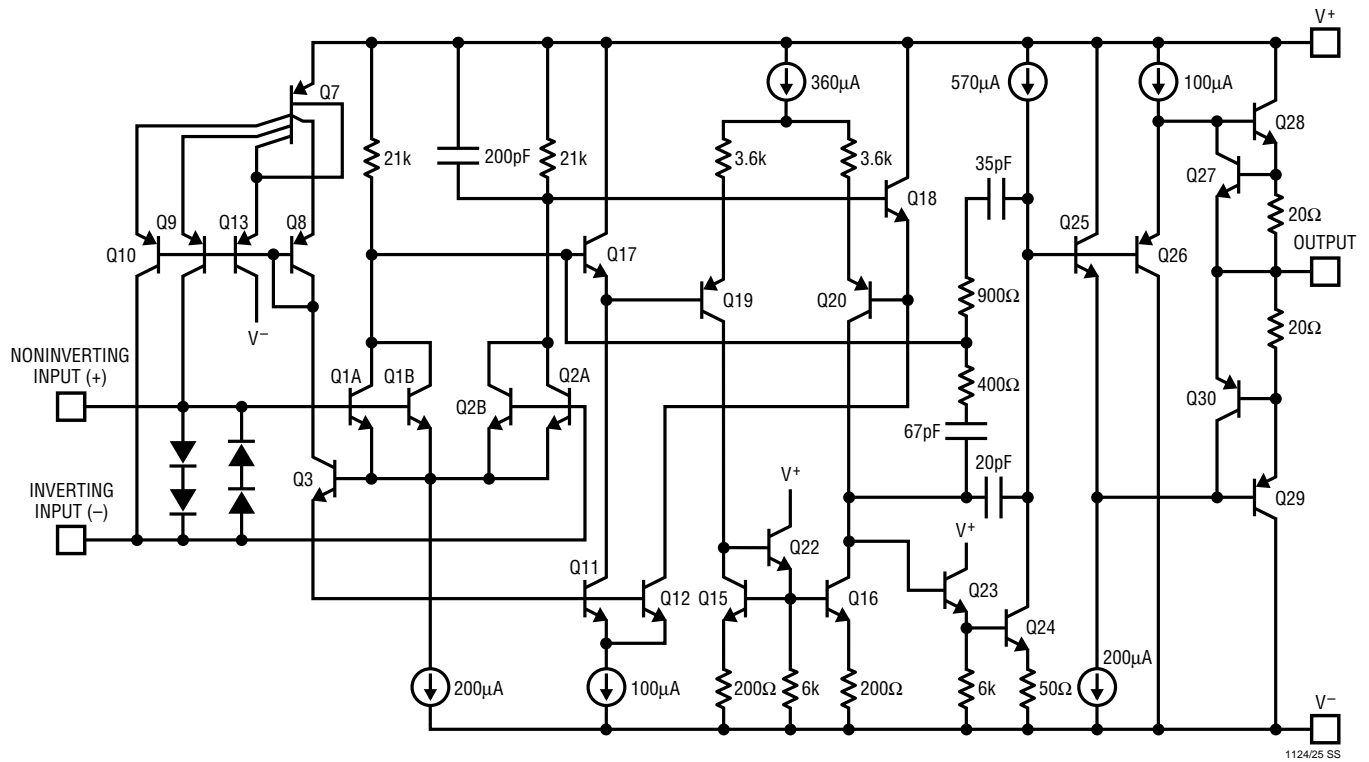

PACKAGE DESCRIPTION Dimensions in inches (millimeters) unless otherwise noted.

J8 Package
8-Lead CERDIP (Narrow 0.300, Hermetic)
 (LTC DWG # 05-08-1110)

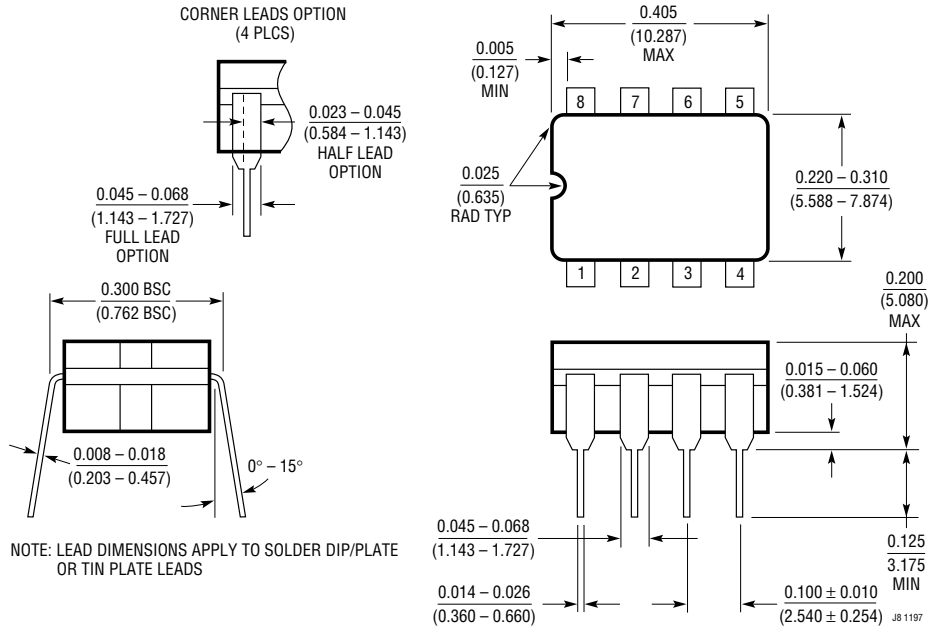

N8 Package
8-Lead PDIP (Narrow 0.300)
 (LTC DWG # 05-08-1510)

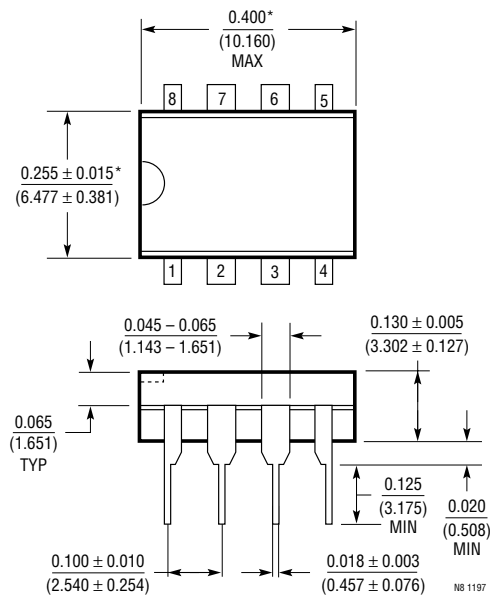

*THESE DIMENSIONS DO NOT INCLUDE MOLD FLASH OR PROTRUSIONS.
 MOLD FLASH OR PROTRUSIONS SHALL NOT EXCEED 0.010 INCH (0.254mm)

PACKAGE DESCRIPTION Dimensions in inches (millimeters) unless otherwise noted.

S8 Package
8-Lead Plastic Small Outline (Narrow 0.150)
 (LTC DWG # 05-08-1610)

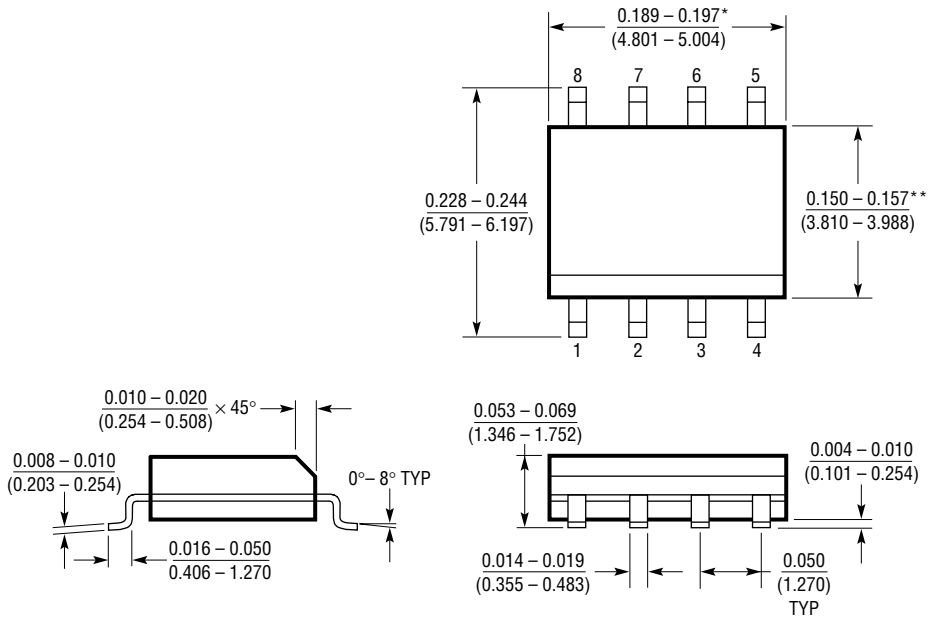

*DIMENSION DOES NOT INCLUDE MOLD FLASH. MOLD FLASH SHALL NOT EXCEED 0.006" (0.152mm) PER SIDE
 **DIMENSION DOES NOT INCLUDE INTERLEAD FLASH. INTERLEAD FLASH SHALL NOT EXCEED 0.010" (0.254mm) PER SIDE

S08 0996

PACKAGE DESCRIPTION Dimensions in inches (millimeters) unless otherwise noted.

J Package
14-Lead CERDIP (Narrow 0.300, Hermetic)
 (LTC DWG # 05-08-1110)

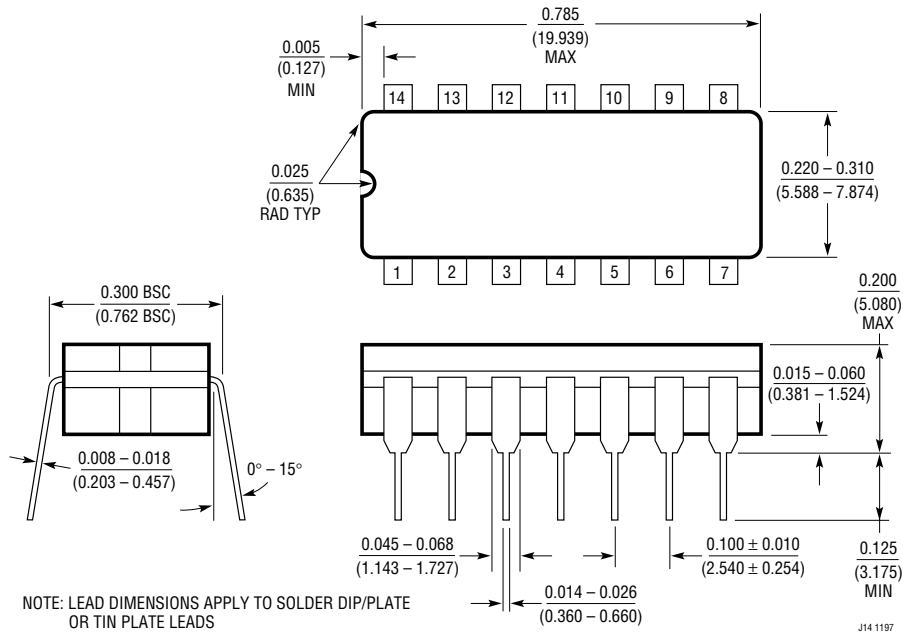

N Package
14-Lead PDIP (Narrow 0.300)
 (LTC DWG # 05-08-1510)

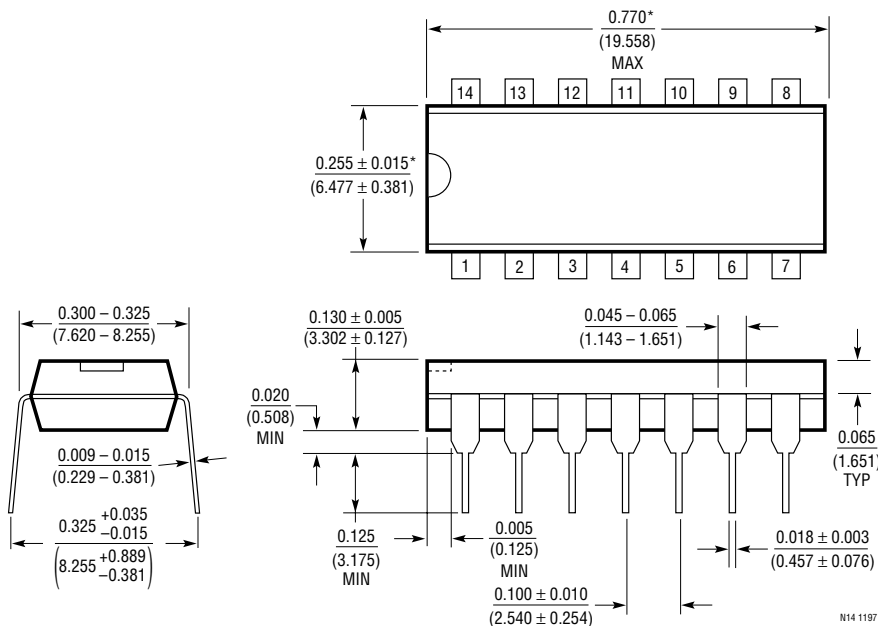

PACKAGE DESCRIPTION Dimensions in inches (millimeters) unless otherwise noted.

SW Package
16-Lead Plastic Small Outline (Wide 0.300)
 (LTC DWG # 05-08-1620)

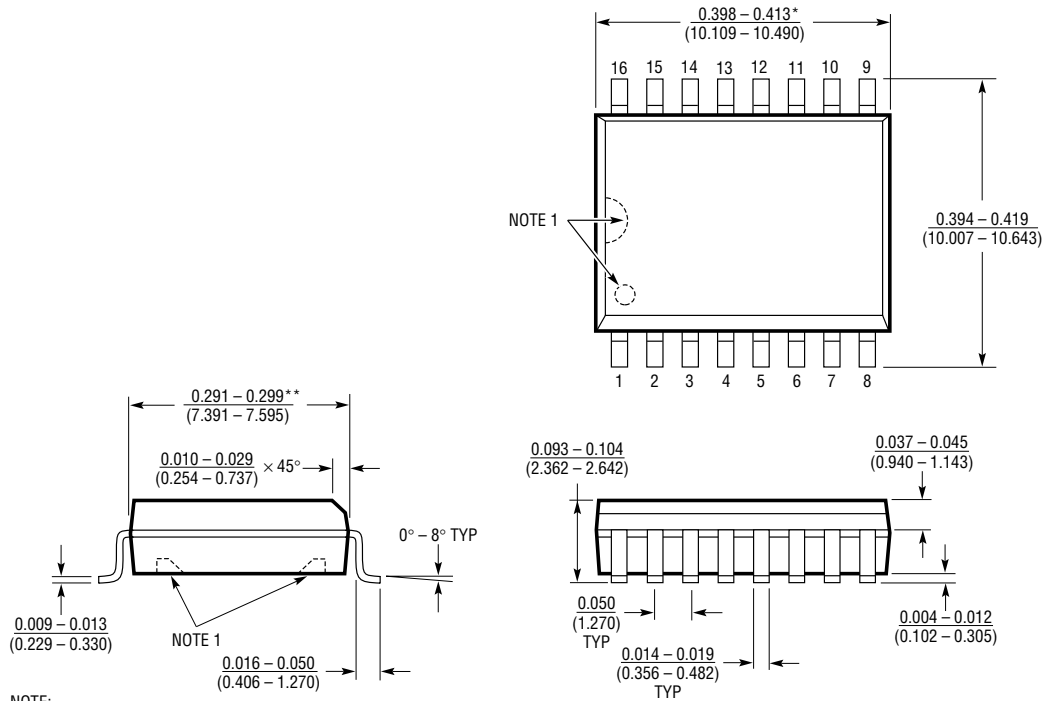

NOTE:
 1. PIN 1 IDENT. NOTCH ON TOP AND CAVITIES ON THE BOTTOM OF PACKAGES ARE THE MANUFACTURING OPTIONS. THE PART MAY BE SUPPLIED WITH OR WITHOUT ANY OF THE OPTIONS
 *DIMENSION DOES NOT INCLUDE MOLD FLASH. MOLD FLASH SHALL NOT EXCEED 0.006" (0.152mm) PER SIDE
 **DIMENSION DOES NOT INCLUDE INTERLEAD FLASH. INTERLEAD FLASH SHALL NOT EXCEED 0.010" (0.254mm) PER SIDE

S16 (WIDE) 0396

TYPICAL APPLICATION

Strain Gauge Signal Conditioner with Bridge Excitation

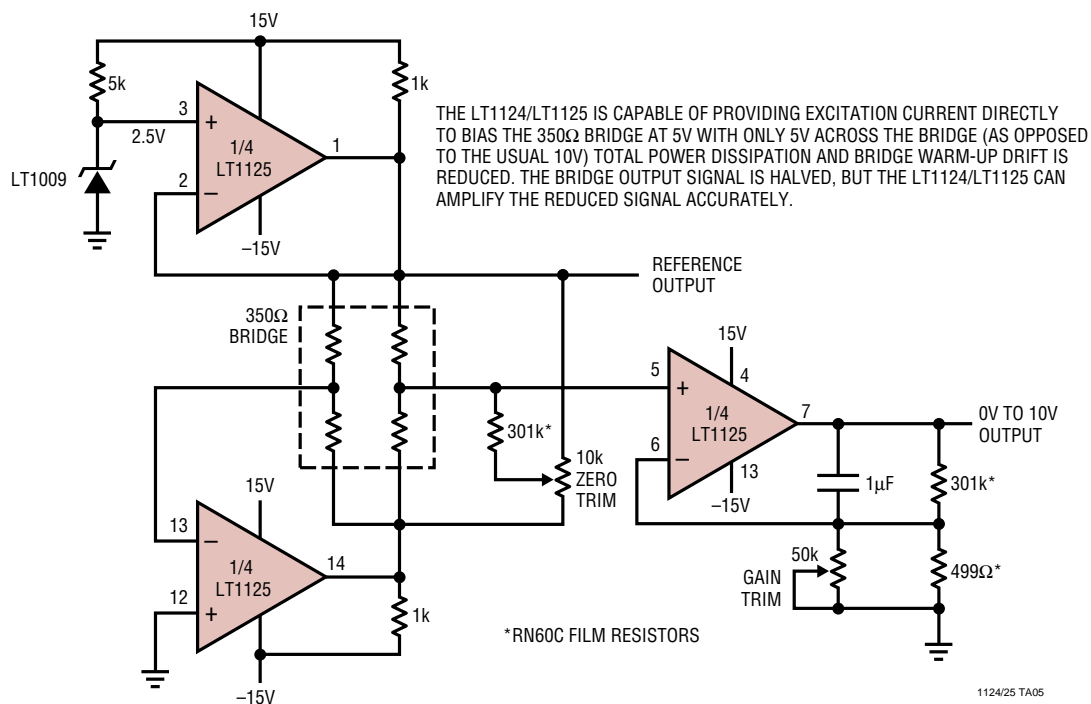

RELATED PARTS

PART NUMBER	DESCRIPTION	COMMENTS
LT1007	Single Low Noise, Precision Op Amp	2.5nV/√Hz 1kHz Voltage Noise
LT1028/LT1128	Single Low Noise, Precision Op Amps	0.85nV/√Hz Voltage Noise
LT1112/LT1114	Dual/Quad Precision Picoamp Input	250pA Max I _B
LT1113	Dual Low Noise JFET Op Amp	4.5nV/√Hz Voltage Noise, 10fA/√Hz Current Noise
LT1126/LT1127	Decompensated LT1124/LT1125	11V/μs Slew Rate
LT1169	Dual Low Noise JFET Op Amp	6nV/√Hz Voltage Noise, 1fA/√Hz Current Noise, 10pA Max I _B
LT1792	Single LT1113	4.2nV/√Hz Voltage Noise, 10fA/√Hz Current Noise
LT1793	Single LT1169	6nV/√Hz Voltage Noise, 1fA/√Hz Current Noise, 10pA Max I _B