

Fast Settling, JFET Input Operational Amplifier

FEATURES

- 100% Tested Settling Time to 1mV at Sum Node, 10V Step Tested with Fixed Feedback Capacitor

340ns Typ
540ns Max
- Slew Rate

60V/μs Min
14MHz
- Gain Bandwidth Product

1.2 MHz
60°
- Power Bandwidth (20Vp-p)
- Unity Gain Stable; Phase Margin
- Input Offset Voltage

600μV Max

- Input Bias Current

25°C 75pA Max
70°C 600pA Max
- Input Offset Current

25°C 40pA Max
70°C 150pA Max
- Low Distortion

APPLICATIONS

- Fast 12-Bit D/A Output Amplifiers
- High Speed Buffers
- Fast Sample and Hold Amplifiers
- High Speed Integrators
- Voltage to Frequency Converters
- Active Filters
- Log Amplifiers
- Peak Detectors

DESCRIPTION

The LT1122 JFET input operational amplifier combines high speed and precision performance.

A unique poly-gate JFET process minimizes gate series resistance and gate-to-drain capacitance, facilitating wide bandwidth performance, without degrading JFET transistor matching.

It slews at 80V/μs and settles in 340ns. The LT1122 is internally compensated to be unity gain stable, yet it has a bandwidth of 14MHz at a supply current of only 7mA. Its speed makes the LT1122 an ideal choice for fast settling 12-bit data conversion and acquisition systems.

The LT1122 offset voltage of 120μV, and voltage gain of 500,000 also support the 12-bit accurate applications.

The input bias current of 10pA and offset current of 4pA combined with its speed allow the LT1122 to be used in such applications as high speed sample and hold amplifiers, peak detectors, and integrators.

TYPICAL APPLICATION

12-Bit Voltage Output D/A Converter

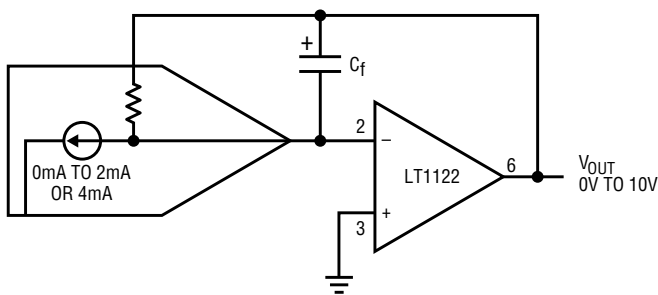

12-BIT CURRENT OUTPUT D/A CONVERTER
 $C_f = 5\text{pF TO } 17\text{pF}$
 (DEPENDENT ON D/A CONVERTER USED)

LT1122-TA01

Large-Signal Response

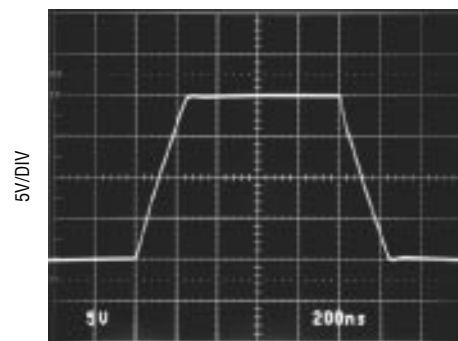

200ns/DIV
 $AV = -1$

1122 TA07

ABSOLUTE MAXIMUM RATINGS

Supply Voltage $\pm 20V$
 Differential Input Voltage $\pm 40V$
 Input Voltage $\pm 20V$
 Output Short Circuit Duration Indefinite
 Lead Temperature (Soldering, 10 sec.) $300^{\circ}C$

Operating Temperature Range
 LT1122AM/BM/CM/DM $-55^{\circ}C$ to $125^{\circ}C$
 LT1122AC/BC/CC/DC/CS/DS $-40^{\circ}C$ to $85^{\circ}C$
 Storage Temperature Range
 All Devices $-65^{\circ}C$ to $150^{\circ}C$

PACKAGE/ORDER INFORMATION

TOP VIEW	ORDER PART NUMBER	TOP VIEW	ORDER PART NUMBER
<p>N8 PACKAGE 8-LEAD PLASTIC DIP</p> <p>J8 PACKAGE 8-LEAD HERMETIC DIP</p> <p>$T_{JMAX} = 150^{\circ}C$, $\theta_{JA} = 130^{\circ}C/W$ (N8) $T_{JMAX} = 175^{\circ}C$, $\theta_{JA} = 100^{\circ}C/W$ (J8)</p>	LT1122AMJ8 LT1122BMJ8 LT1122CMJ8 LT1122DMJ8 LT1122ACJ8 LT1122BCJ8	<p>S8 PACKAGE 8-LEAD PLASTIC SOIC</p> <p>$T_{JMAX} = 150^{\circ}C$, $\theta_{JA} = 190^{\circ}C/W$</p>	LT1122CCJ8 LT1122DCJ8 LT1122ACN8 LT1122BCN8 LT1122CCN8 LT1122DCN8
			LT1122CS8 LT1122DS8
			PART MARKING
			1122C 1122D

Consult factory for Industrial grade parts.

ELECTRICAL CHARACTERISTICS $V_S = \pm 15V$, $T_A = 25^{\circ}C$, $V_{CM} = 0V$ unless otherwise noted. (Note 1)

SYMBOL	PARAMETER	CONDITIONS	LT1122AM/BM LT1122AC/BC			LT1122CM/DM LT1122CC/DC LT1122CS/DS			UNITS
			MIN	TYP	MAX	MIN	TYP	MAX	
V_{OS}	Input Offset Voltage			120	600		130	900	μV
I_{OS}	Input Offset Current			4	40		5	50	pA
I_B	Input Bias Current			10	75		12	100	pA
	Input Resistance								
	Differential	$V_{CM} = -10V$ to $+8V$		10^{12}			10^{12}		Ω
	Common Mode	$V_{CM} = +8V$ to $+11V$		10^{12}			10^{12}		Ω
				10^{11}			10^{11}		Ω
	Input Capacitance			4			4		pF
S_R	Slew Rate	$A_V = -1$	60	80		50	75		V/ μs
	Settling Time (Note 2)	$+10V$ to $0V$, $-10V$ to $0V$ 100% Tested: A and C Grades to 1mV at Sum Node B and D Grades to 1mV at Sum Node All Grades to 0.5mV at Sum Node		340	540		350	590	ns
				350			360		ns
				450			470		ns
GBW	Gain Bandwidth Product			14			13		MHz
	Power Bandwidth	$V_{OUT} = 20V_{p-p}$		1.2			1.1		MHz
A_{VOL}	Large Signal Voltage Gain	$V_{OUT} = \pm 10V$, $R_L = 2k\Omega$ $V_{OUT} = \pm 10V$, $R_L = 600\Omega$	180	500		150	450		V/mV
			130	250		110	220		V/mV
CMRR	Common Mode Rejection Ratio	$V_{CM} = \pm 10V$	83	99		80	98		dB
	Input Voltage Range	(Note 3)	± 10.5	± 11		± 10.5	± 11		V
PSRR	Power Supply Rejection Ratio	$V_S = \pm 10V$ to $\pm 18V$	86	103		82	101		dB
	Input Noise Voltage	0.1Hz to 10Hz		3.0			3.3		μV_{p-p}
	Input Noise Voltage Density	$f_0 = 100Hz$ $f_0 = 10kHz$		25			27		nV/\sqrt{Hz}
				14			15		nV/\sqrt{Hz}
	Input Noise Current Density	$f_0 = 100Hz$, $f_0 = 10kHz$		2			2		fA/ \sqrt{Hz}

ELECTRICAL CHARACTERISTICS $V_S = \pm 15V$, $T_A = 25^\circ C$, $V_{CM} = 0V$ unless otherwise noted.

SYMBOL	PARAMETER	CONDITIONS	LT1122AM/BM LT1122AC/BC			LT1122CM/DM LT1122CC/DC LT1122CS/DS			UNITS
			MIN	TYP	MAX	MIN	TYP	MAX	
V_{OUT}	Output Voltage Swing	$R_L = 2k\Omega$ $R_L = 600\Omega$	± 12	± 12.5		± 12	± 12.5		V
			± 11.5	± 12		± 11.5	± 12		V
I_S	Supply Current			7.5	10		7.8	11	mA
	Minimum Supply voltage	(Note 4)	± 5			± 5			V
	Offset Adjustment Range	$R_{POT} \geq 10k$, Wiper to V^+	± 4	± 10		± 4	± 10		mV

$V_S = \pm 15V$, $V_{CM} = 0V$, $0^\circ C \leq T_A \leq 70^\circ C$, unless otherwise noted. (Note 1)

SYMBOL	PARAMETER	CONDITIONS	LT1122AC/BC			LT1122CC/DC LT1122CS/DS			UNITS
			MIN	TYP	MAX	MIN	TYP	MAX	
V_{OS}	Input Offset Voltage			350	1400		400	2000	μV
	Average Temperature Coefficient of Input Offset Voltage			5	18		6	25	$\mu V/^\circ C$
I_{OS}	Input Offset Current			12	150		15	200	pA
I_B	Input Bias Current			80	600		90	800	pA
A_{VOL}	Large Signal Voltage Gain	$V_{OUT} = \pm 10V$, $R_L \geq 2k\Omega$		120	380		100	340	V/mV
CMRR	Common Mode Rejection Ratio	$V_{CM} = \pm 10V$		82	98		78	96	dB
PSRR	Power Supply Rejection Ratio	$V_S = \pm 10V$ to $\pm 17V$		84	101		80	99	dB
	Input Voltage Range			± 10	± 10.8		± 10	± 10.8	V
V_{OUT}	Output Voltage Swing	$R_L = 2k\Omega$		± 11.5	± 12.4		± 11.5	± 12.4	V
S_R	Slew Rate	$A_V = -1$		50	70		40	65	V/ μs

$V_S = \pm 15V$, $V_{CM} = 0V$, $-55^\circ C \leq T_A \leq 125^\circ C$, unless otherwise noted. (Note 1)

SYMBOL	PARAMETER	CONDITIONS	LT1122AM/BM			LT1122CM/DM			UNITS
			MIN	TYP	MAX	MIN	TYP	MAX	
V_{OS}	Input Offset Voltage			650	2400		800	3400	μV
	Average Temperature Coefficient of Input Offset Voltage			6	18		7	25	$\mu V/^\circ C$
I_{OS}	Input Offset Current			0.5	6		0.6	9	nA
I_B	Input Bias Current			6	25		7	35	nA
A_{VOL}	Large Signal Voltage Gain	$V_{OUT} = \pm 10V$, $R_L \geq 2k\Omega$		70	230		60	200	V/mV
CMRR	Common Mode Rejection Ratio	$V_{CM} = \pm 10V$		80	97		76	94	dB
PSRR	Power Supply Rejection Ratio	$V_S = \pm 10V$ to $\pm 17V$		83	100		78	98	dB
	Input Voltage Range			± 10	± 10.5		± 10	± 10.5	V
V_{OUT}	Output Voltage Swing	$R_L = 2k\Omega$		± 11.3	± 12.1		± 11.3	± 12.1	V
S_R	Slew Rate	$A_V = -1$		45	60		35	55	V/ μs

The ● denotes the specifications which apply over the full operating temperature range.

Note 1: The LT1122 is measured in an automated tester in less than one second after application of power. Depending on the package used, power dissipation, heat sinking, and air flow conditions, the fully warmed up chip temperature can be $10^\circ C$ to $50^\circ C$ higher than the ambient temperature.

Note 2: Settling time is 100% tested for A and C grades using the settling time test circuit shown. This test is not included in quality assurance sample testing.

Note 3: Input voltage range functionality is assured by testing offset voltage at the input voltage range limits to a maximum of 4mV (A, B grades), to 5.7mV (C, D grades).

Note 4: Minimum supply voltage is tested by measuring offset voltage to 7mV maximum at $\pm 5V$ supplies.

Note 5: The LT1122 is not tested and not quality-assurance-sampled at $-40^\circ C$ and at $85^\circ C$. These specifications are guaranteed by design, correlation and/or inference from $-55^\circ C$, $0^\circ C$, $25^\circ C$, $70^\circ C$ and/or $125^\circ C$ tests.

ELECTRICAL CHARACTERISTICS

$V_S = \pm 15V$, $V_{CM} = 0V$, $-40^\circ C \leq T_A \leq 85^\circ C$, unless otherwise noted. (Note 5)

SYMBOL	PARAMETER	CONDITIONS	LT1122AC/BC			LT1122CC/DC LT1122CS/DS			UNITS
			MIN	TYP	MAX	MIN	TYP	MAX	
V_{OS}	Input Offset Voltage			450	1900		500	2700	μV
	Average Temperature Coefficient of Input Offset Voltage			6	20		7	28	$\mu V/^\circ C$
I_{OS}	Input Offset Current			30	600		40	900	μA
I_B	Input Bias Current			230	2000		260	2700	μA
A_{VOL}	Large Signal Voltage Gain	$V_{OUT} = \pm 10V$, $R_L \geq 2k\Omega$		95	340		80	300	V/mV
CMRR	Common Mode Rejection Ratio	$V_{CM} = \pm 10V$		80	98		76	96	dB
PSRR	Power Supply Rejection Ratio	$V_S = \pm 10V$ to $\pm 17V$		83	100		78	98	dB
	Input Voltage Range			± 10	± 10.6		± 10	± 10.6	V
V_{OUT}	Output Voltage Swing	$R_L = 2k\Omega$		± 11.3	± 12.2		± 11.3	± 12.2	V
S_R	Slew Rate	$A_V = -1$		45	65		35	60	$V/\mu s$

Settling Time Test Fixture

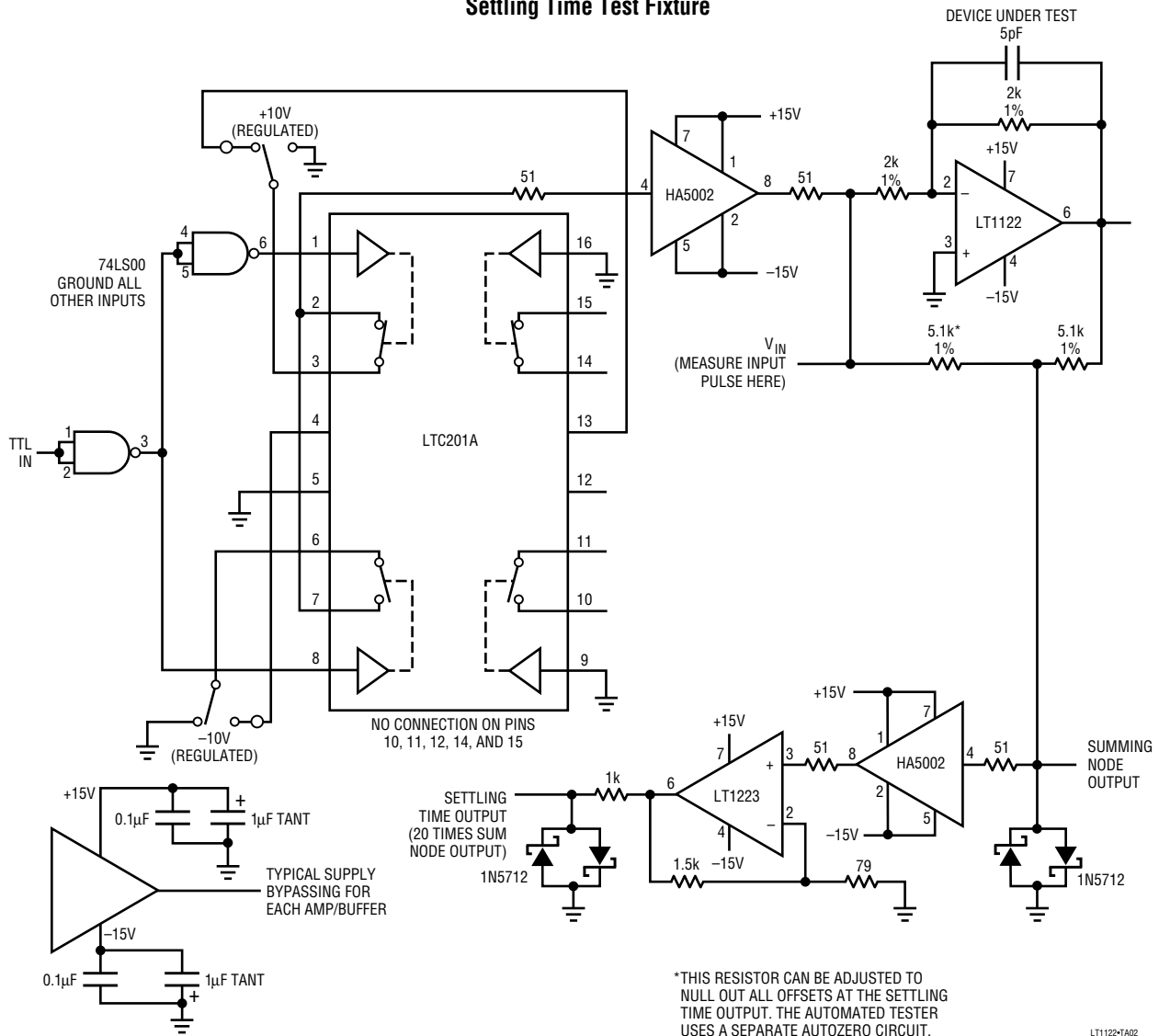

TYPICAL PERFORMANCE CHARACTERISTICS

Settling Time
(Input From -10V to 0V)

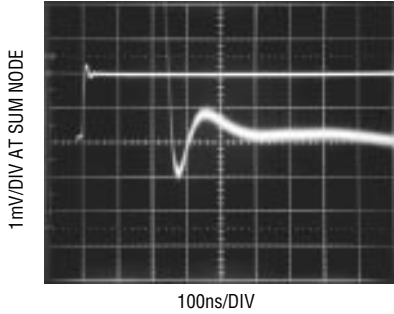

Settling Time
(Input From +10V to 0V)

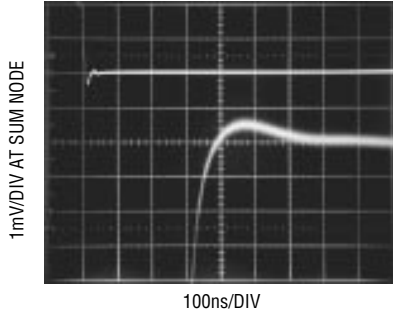

Settling Time
(Input From 0V to +10V)

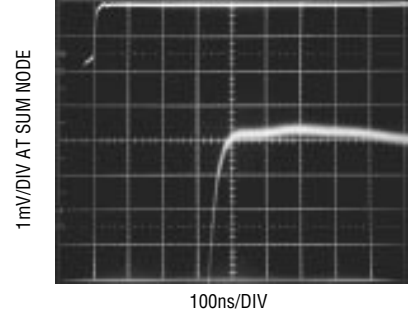

Settling Time
(Input From 0V to -10V)

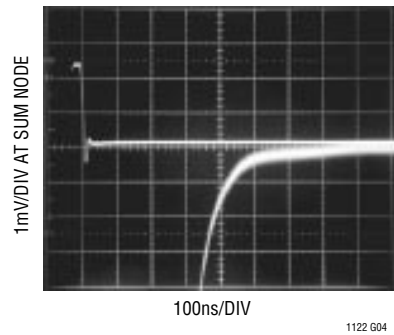

Large Signal Response

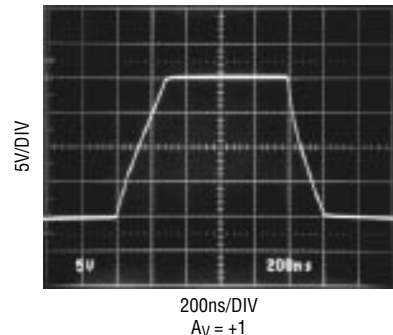

Undistorted Output Swing vs Frequency

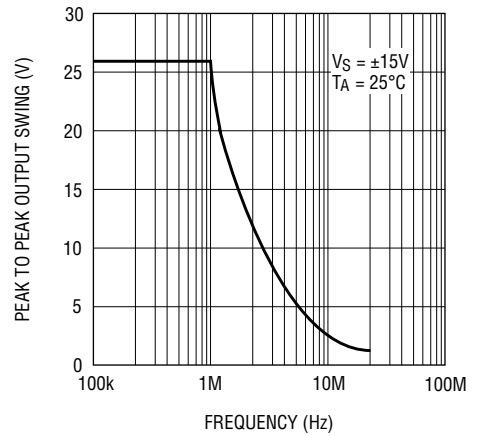

Voltage Gain vs Frequency

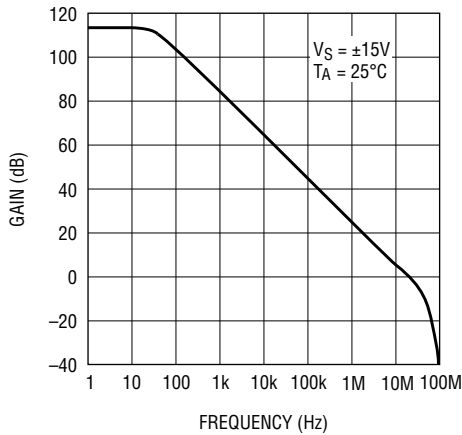

Gain, Phase vs Frequency

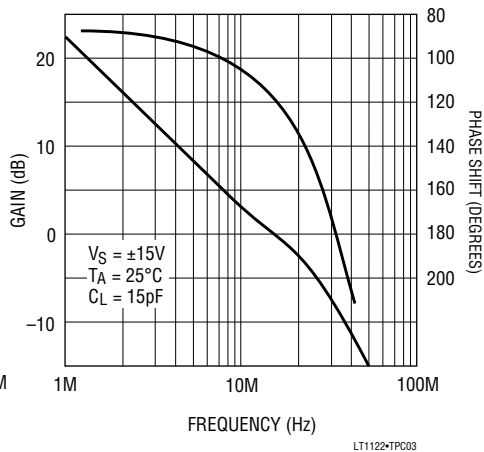

Common Mode Rejection vs Frequency

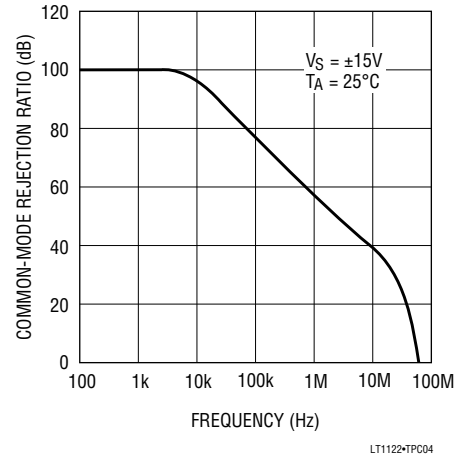

TYPICAL PERFORMANCE CHARACTERISTICS

Distribution of Input Offset Voltage

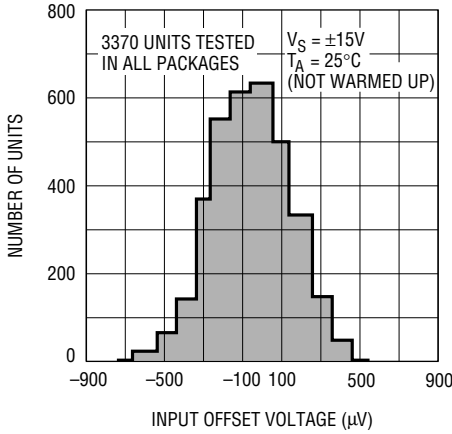

LT1122-TPC05

Input Bias and Offset Currents Over Temperature

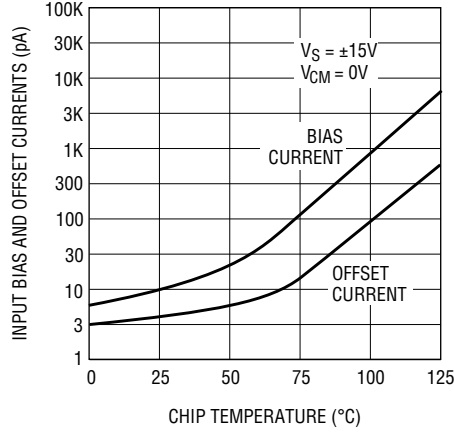

LT1122-TPC06

Bias and Offset Currents Over The Common-Mode Range

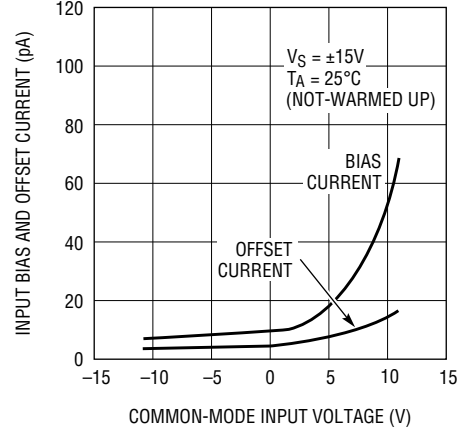

LT1122-TPC07

Warm-up Drift

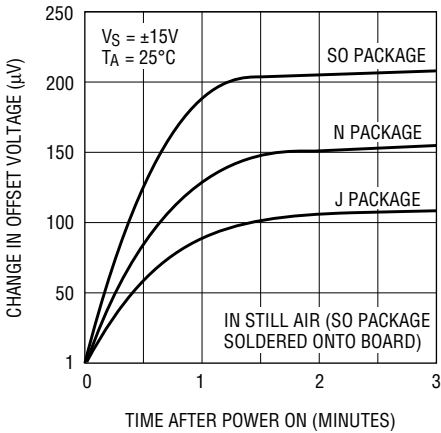

LT1122-TPC08

Noise Spectrum

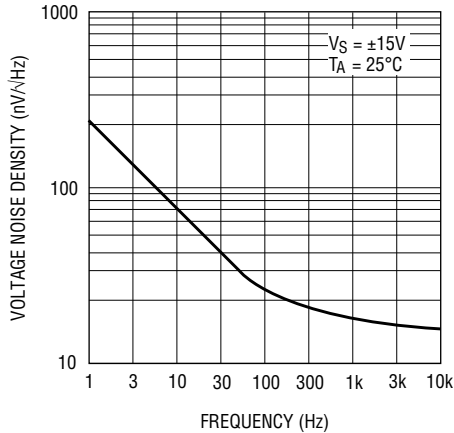

LT1122-TPC09

0.1Hz to 10Hz Noise

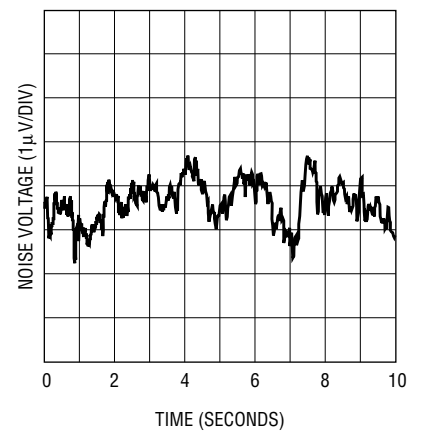

LT1122-TPC10

Total Harmonic Distortion + Noise vs Frequency Inverting Gain

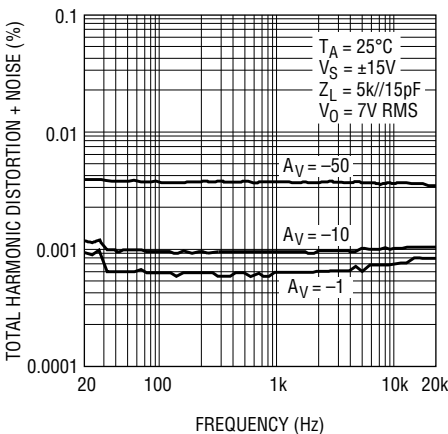

LT1122-TPC11

Total Harmonic Distortion + Noise vs Frequency Non-Inverting Gain

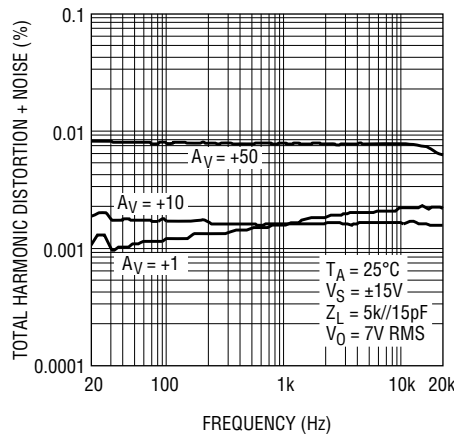

LT1122-TPC12

Intermodulation Distortion (CCIF Method) vs Frequency LT1122 and LF156*

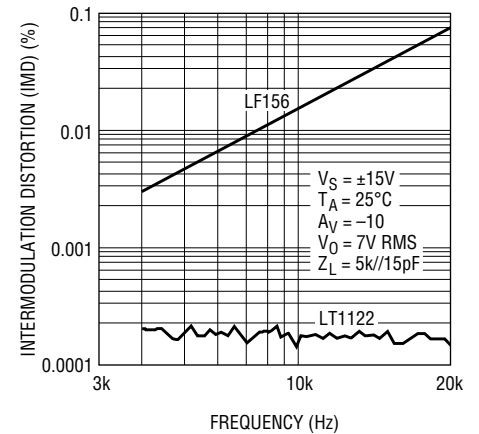

*SEE LT1115 DATA SHEET FOR DEFINITION OF CCIF TESTING

LT1122-TPC13

APPLICATIONS INFORMATION

Settling Time Measurements

Settling time test circuits shown on some competitive devices' data sheets require:

1. A "flat top" pulse generator. Unfortunately, flat top pulse generators are not commercially available.
2. A variable feedback capacitor around the device under test. This capacitor varies over a four to one range. Presumably, as each op amp is measured for settling time, the capacitor is fine tuned to optimize settling time for that particular device.
3. A small inductor load to optimize settling.

The LT1122's settling time is 100% tested in the test circuit shown. No "flat top" pulse generator is required. The test circuit can be readily constructed, using commercially available ICs. Of course, standard high frequency board construction techniques should be followed. All LT1122s are measured with a constant feedback capacitor. No fine tuning is required.

Speed Boost/Overcompensation Terminal

Pin 8 of the LT1122 can be used to change the input stage operating current of the device. Shorting pin 8 to the positive supply (Pin 7) increases slew rate and bandwidth by about 25%, but at the expense of a reduction in phase margin by approximately 18 degrees. Unity gain capacitive load handling decreases from typically 500pF to 100pF.

Conversely, connecting a 15k resistor from pin 8 to ground pulls 1mA out of pin 8 (with $V^+ = 15V$). This reduces slew rate and bandwidth by 25%. Phase margin and capacitive load handling improve; the latter typically increasing to 800pF.

High Speed Operation

As with most high speed amplifiers, care should be taken with supply decoupling, lead dress and component placement.

The power supply connections to the LT1122 must maintain a low impedance to ground over a bandwidth of 20MHz. This is especially important when driving a significant resistive or capacitive load, since all current delivered to the load comes from the power supplies. Multiple high quality bypass capacitors are recommended for each power supply line in any critical application. A 0.1 μ F ceramic and a 1 μ F electrolytic capacitor, as shown, placed as close as possible to the amplifier (with short lead lengths to power supply common) will assure adequate high frequency bypassing, in most applications.

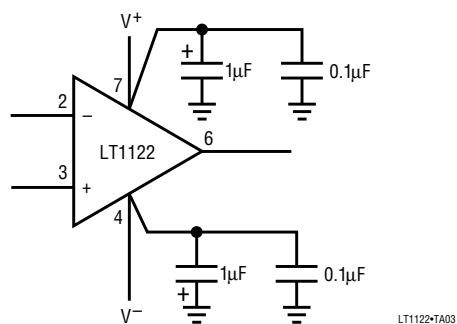

LT1122-TA03

When the feedback around the op amp is resistive (R_F), a pole will be created with R_F , the source resistance (R_S , C_S), and the amplifier input capacitance ($C_{IN} \approx 4pF$). In low closed loop gain configurations and with R_S and R_F in the kilohm range, this pole can create excess phase shift and even oscillation. A small capacitor (C_F) in parallel with R_F eliminates this problem. With $R_S (C_S + C_{IN}) = R_F C_F$, the effect of the feedback pole is completely removed.

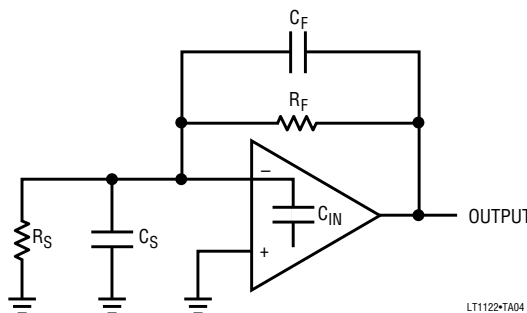

LT1122-TA04

TYPICAL APPLICATIONS

Quartz Stabilized Oscillator With 9ppm Distortion

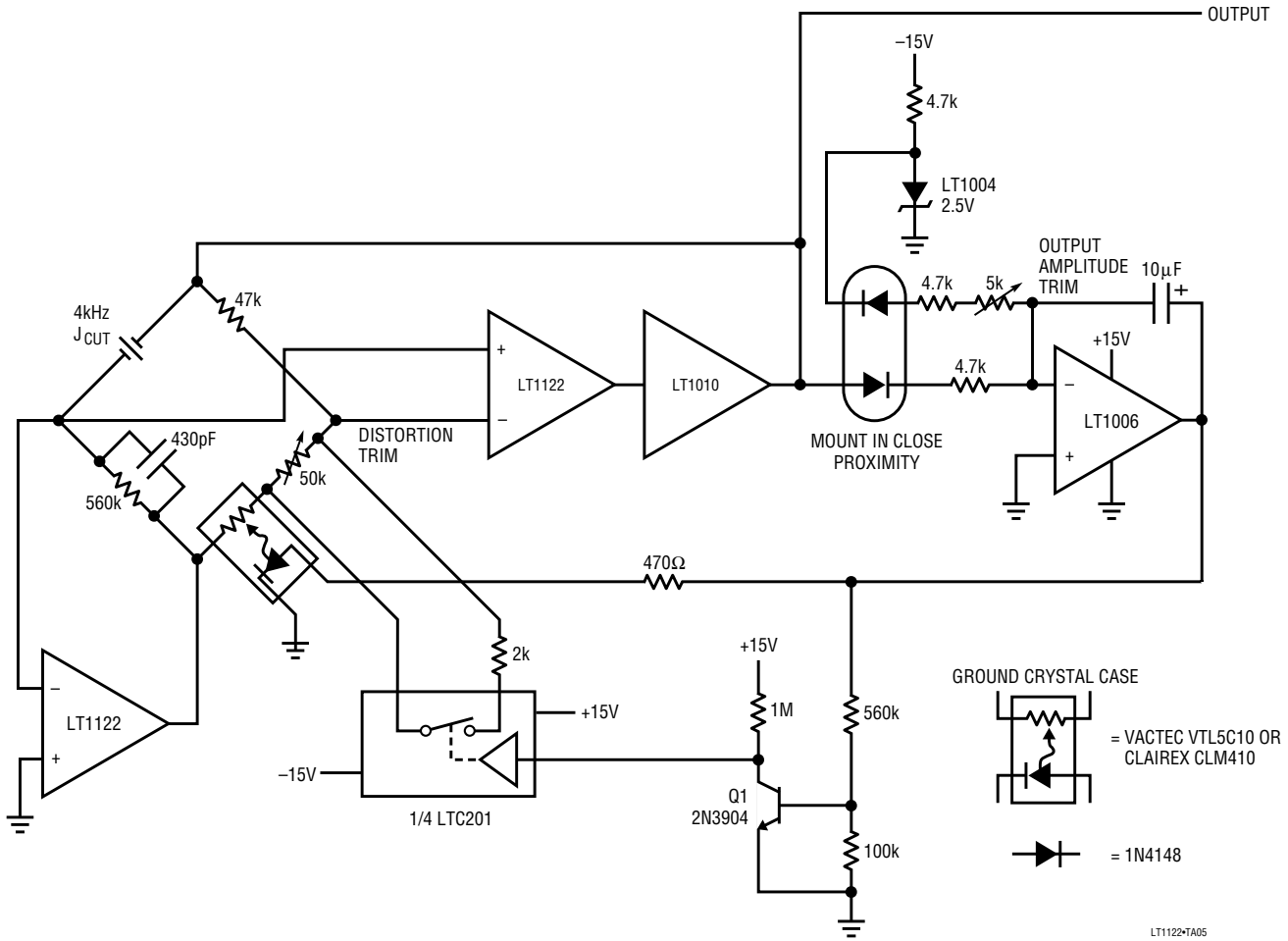

Wide-Band, Filtered, Full Wave Rectifier

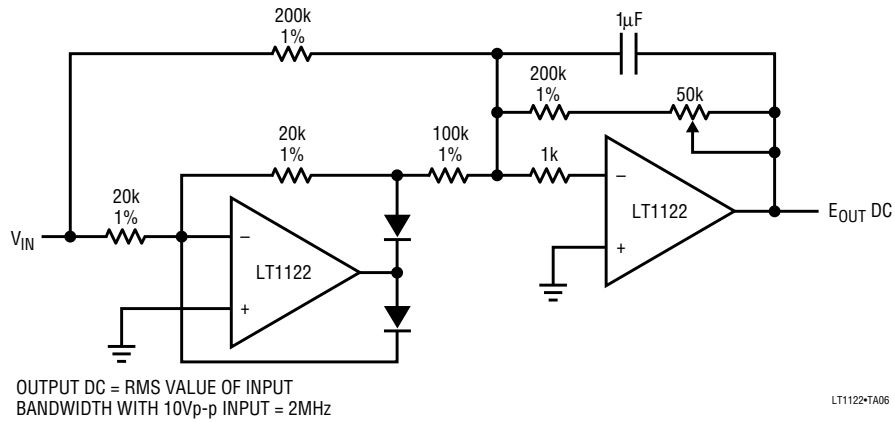

PACKAGE DESCRIPTION

Please see the 1994 Linear Databook Volume III for package descriptions.