

# LSF010x 1/2/8 Channel Auto-Bidirectional Multi-Voltage Level Translator for Open-Drain and Push-Pull Applications

## 1 Features

- Provides bidirectional voltage translation with no direction pin
- Supports up to 100-MHz up translation and greater than 100-MHz down translation at  $\leq 30$  pF cap load and up to 40-MHz up/down translation at 50 pF cap load
- Allows bidirectional voltage-level translation between
  - 0.95 V  $\leftrightarrow$  1.8/2.5/3.3/5 V
  - 1.2 V  $\leftrightarrow$  1.8/2.5/3.3/5 V
  - 1.8 V  $\leftrightarrow$  2.5/3.3/5 V
  - 2.5 V  $\leftrightarrow$  3.3/5 V
  - 3.3 V  $\leftrightarrow$  5 V
- Low standby current
- 5-V tolerance I/O port to support TTL
- Low  $R_{ON}$  provides less signal distortion
- High-impedance I/O pins for EN = Low
- Flow-through pinout for easy PCB trace routing
- Latch-up performance  $>100$  mA per JESD 17
- $-40^{\circ}\text{C}$  to  $125^{\circ}\text{C}$  operating temperature range

## 2 Applications

- GPIO, MDIO, PMBus, SMBus, SDIO, UART, I<sup>2</sup>C, and other interfaces in telecom infrastructure
- [Enterprise systems](#)
- [Communications equipment](#)
- [Personal electronics](#)
- [Industrial applications](#)

## 3 Description

The LSF family of devices supports bidirectional voltage translation without the need for DIR pin which minimizes system effort (for PMBus, I<sup>2</sup>C, SMBus, and so forth). The LSF family of devices supports up to 100-MHz up translation and greater than 100-MHz down translation at  $\leq 30$  pF cap load and up to 40-MHz up/down translation at 50 pF cap load which allows the LSF family to support more consumer or telecom interfaces (MDIO or SDIO).

LSF family supports 5-V tolerance on I/O port which makes it compatible with TTL levels in industrial and telecom applications. The LSF family is able to set up different voltage translation levels on each channel which makes it very flexible.

### Package Information

PART NUMBER	PACKAGE <sup>(1)</sup>	BODY SIZE (NOM)
LSF0101	SON (DRY, 6)	1.45 mm $\times$ 1.00 mm
	X2SON (DTQ, 6)	1.00 mm $\times$ 0.80 mm
LSF0102	X2SON (DQE, 8)	1.40 mm $\times$ 1.00 mm
	DSBGA (YZT, 8)	1.90 mm $\times$ 1.00 mm
	SM8 (DCT, 8)	2.80 mm $\times$ 2.95 mm
	VSSOP (DCU, 8)	2.30 mm $\times$ 2.00 mm
	SOT-23 (DDF, 8)	1.60 mm $\times$ 2.90 mm
LSF0108	VQFN (RKS, 20)	4.50 mm $\times$ 2.50 mm
	TSSOP (PW, 20)	4.40 mm $\times$ 6.50 mm
	VSSOP (DGS, 20)	3.00 mm $\times$ 5.10 mm

(1) For all available packages, see the orderable addendum at the end of the data sheet.

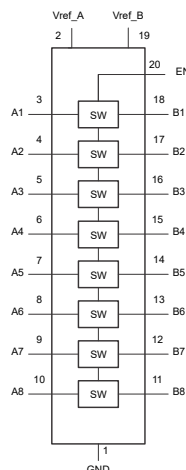

**Functional Block Diagram**



## Table of Contents

<b>1 Features</b> .....	1	6.15 LSF0108 AC Performance (Translating Up) Switching Characteristics, $V_{GATE} = 2.5\text{ V}$ .....	10
<b>2 Applications</b> .....	1	6.16 Typical Characteristics.....	11
<b>3 Description</b> .....	1	<b>7 Parameter Measurement Information</b> .....	12
<b>4 Revision History</b> .....	2	<b>8 Detailed Description</b> .....	13
<b>5 Pin Configuration and Functions</b> .....	4	8.1 Overview.....	13
<b>6 Specifications</b> .....	7	8.2 Functional Block Diagram.....	13
6.1 Absolute Maximum Ratings.....	7	8.3 Feature Description.....	13
6.2 ESD Ratings.....	7	8.4 Device Functional Modes.....	14
6.3 Recommended Operating Conditions.....	7	<b>9 Application and Implementation</b> .....	16
6.4 Thermal Information.....	7	9.1 Application Information.....	16
6.5 Thermal Information.....	8	9.2 Typical Applications.....	16
6.6 Thermal Information.....	8	<b>10 Power Supply Recommendations</b> .....	23
6.7 Electrical Characteristics.....	9	<b>11 Layout</b> .....	23
6.8 LSF0101/02 AC Performance (Translating Down) Switching Characteristics, $V_{GATE} = 3.3\text{ V}$ .....	9	11.1 Layout Guidelines.....	23
6.9 LSF0108 AC Performance (Translating Down) Switching Characteristics, $V_{GATE} = 3.3\text{ V}$ .....	9	11.2 Layout Example.....	23
6.10 LSF0101/02 AC Performance (Translating Down) Switching Characteristics, $V_{GATE} = 2.5\text{ V}$ .....	9	<b>12 Device and Documentation Support</b> .....	24
6.11 LSF0108 AC Performance (Translating Down) Switching Characteristics, $V_{GATE} = 2.5\text{ V}$ .....	10	12.1 Related Documentation.....	24
6.12 LSF0101/02 AC Performance (Translating Up) Switching Characteristics, $V_{GATE} = 3.3\text{ V}$ .....	10	12.2 Receiving Notification of Documentation Updates.....	24
6.13 LSF0108 AC Performance (Translating Up) Switching Characteristics, $V_{GATE} = 3.3\text{ V}$ .....	10	12.3 Support Resources.....	24
6.14 LSF0101/02 AC Performance (Translating Up) Switching Characteristics, $V_{GATE} = 2.5\text{ V}$ .....	10	12.4 Trademarks.....	24
		12.5 Electrostatic Discharge Caution.....	24
		12.6 Glossary.....	24
		<b>13 Mechanical, Packaging, and Orderable Information</b> .....	24

## 4 Revision History

NOTE: Page numbers for previous revisions may differ from page numbers in the current version.

Changes from Revision K (May 2021) to Revision L (November 2022)	Page
• Updated the <i>Applications</i> section.....	1
• Updated the <i>Description</i> section.....	1
• Updated the <i>Pin Configuration and Functions</i> section.....	4
• Added DDF and DGS packages. ....	4
• Updated the <i>Thermal Information</i> tables.....	8
• Updated <i>Electrical Characteristics</i> table.....	9
• Updated the <i>Functional Block Diagram</i> section.....	13
• Updated the <i>Auto Bidirectional Voltage Translation</i> section.....	13
• Updated the <i>Output Enable</i> section.....	14
• Updated the <i>Device Functional Modes</i> section.....	14
• Added the <i>Up and Down Translation</i> section.....	15
• Updated the <i>Application Information</i> section.....	16
• Updated the <i>Enable, Disable, and Reference Voltage Guidelines</i> section.....	17
• Added the <i>Bias Circuitry</i> section.....	17
• Added the <i>Single Supply Translation</i> section.....	20

Changes from Revision J (April 2020) to Revision K (May 2021)	Page
• Updated the numbering format for tables, figures, and cross-references throughout the document .....	1
• Updated the <i>Bidirectional Translation</i> section to include inclusive terminology.....	18

<b>Changes from Revision I (June 2019) to Revision J (April 2020)</b>		<b>Page</b>
• Added section <i>Voltage Translation for <math>V_{ref\_B} &lt; V_{ref\_A} + 0.8\text{ V}</math></i> .....		22
<hr/>		
<b>Changes from Revision H (June 2019) to Revision I (July 2019)</b>		<b>Page</b>
• Changed product status from Advance Information mix to Production Data .....		1
• Deleted Advance Information note from the DTQ package in the Device Information table. ....		1
• Deleted Advance Information note from DTQ Package, in the Pin Configuration and Functions section. ....		4
• Deleted Advance Information note for the DTQ package in the Thermal Information table. ....		8
<hr/>		
<b>Changes from Revision G (February 2016) to Revision H (June 2019)</b>		<b>Page</b>
• Added Advance Information note to Device Information table for DTQ package .....		1
• Added DTQ6 pinout drawing to <i>Pin Configurations and Functions</i> section (Advance Information).....		4
• Added Advance Information note to LSF0101 Thermal Information table. ....		8
• General improvements to Application and Implementation section for clarity. ....		16
<hr/>		
<b>Changes from Revision F (October 2015) to Revision G (October 2015)</b>		<b>Page</b>
• Added all available package dimensions in Device Information and changed the pin diagram description.....		1
<hr/>		
<b>Changes from Revision E (July 2015) to Revision F (October 2015)</b>		<b>Page</b>
• Changed Features from "Supports High Speed Translation, Greater Than 100 MHz" to "Supports Up to 100 MHz Up Translation and Greater Than 100 MHz Down Translation at $\leq 30\text{pF}$ Cap Load and Up To 40 MHz Up/Down Translation at 50 pF Cap Load." .....		1
• Updated all propagation delay tables changed from generic to specific LSF devices. ....		9
<hr/>		
<b>Changes from Revision D (October 2014) to Revision E (July 2015)</b>		<b>Page</b>
• Deleted "Less Than 1.5 ns Max Propagation Delay" from Features. ....		1
• Updated ESD Ratings table. ....		7
• Increased MAX value for $T_A$ , Operating free-air temperature, from 85°C to 125°C.....		7
• Updated the <i>Device Functional Modes</i> section.....		14
• Updated the <i>Pull-Up Resistor Sizing</i> section.....		18
<hr/>		
<b>Changes from Revision C (May 2014) to Revision D (August 2014)</b>		<b>Page</b>
• Changed bidirectional voltage level translation from 1.0 to 0.95 .....		1
• Changed YZT package to fix view error. ....		1
• Changed YZT Package, to fix view error. ....		4
• Added $V_{ref\_A}$ footnote.....		17
<hr/>		
<b>Changes from Revision B (May 2014) to Revision C (May 2014)</b>		<b>Page</b>
• Changed LSF0108 status from preview to production.....		1
• Updated document title. ....		1
• Updated Handling Ratings table. ....		7
<hr/>		
<b>Changes from Revision A (January 2014) to Revision B (February 2014)</b>		<b>Page</b>
• Added LSF0108 to data sheet. ....		1
<hr/>		
<b>Changes from Revision * (December 2013) to Revision A (January 2014)</b>		<b>Page</b>
• Updated part number.....		1
• Updated <i>Electrical Characteristics</i> table.....		9

## 5 Pin Configuration and Functions

Pinout drawings are not to scale



**Figure 5-1. LSF0101 DRY Package, 6-Pin SON (Transparent Top View)**

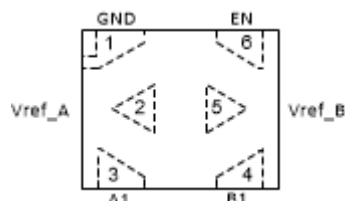

**Figure 5-2. LSF0101 DTQ Package, 6-Pin X2SON (Transparent Top View)**

**Table 5-1. Pin Functions**

PIN		TYPE <sup>(1)</sup>	DESCRIPTION
NAME	DRY, DTQ NO.		
An	3	I/O	Auto-Bidirectional Data port
Bn	4	I/O	
EN	6	I	Enable input; connect to Vref_B and pull-up through a high resistor (200 kΩ). See <a href="#">Using the Enable Pin with the LSF Family</a>
GND	1	—	Ground
Vref_A	2	—	Reference supply voltage.
Vref_B	5	—	For proper device biasing, see <a href="#">Section 9</a> and <a href="#">Understanding the Bias Circuit for the LSF Family</a> .

(1) I = input, O = output

Pinout drawings are not to scale

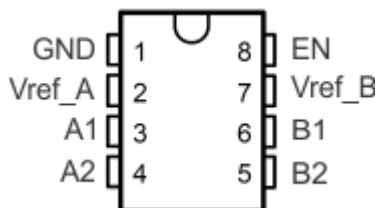

**Figure 5-3. LSF0102 DCT, DCU or DDF Package, 8-Pin SM8, VSSOP, SOT-23 (Top View)**

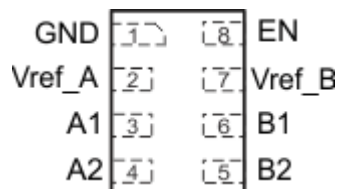
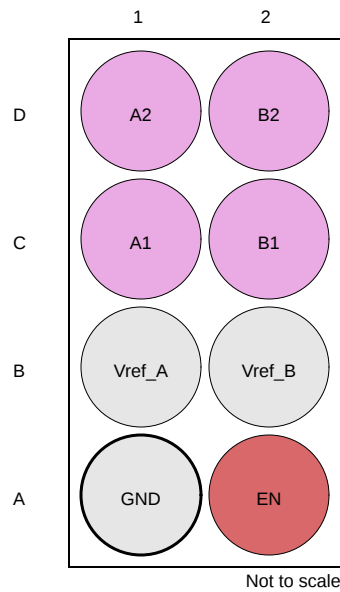

**Figure 5-4. LSF0102 DQE Package, 8-Pin X2SON (Transparent Top View)**

**Table 5-2. Pin Functions**

PIN		TYPE <sup>(1)</sup>	DESCRIPTION
NAME	DCT, DCU, DDF, DQE NO.		
An	3, 4	I/O	Auto-Bidirectional Data port
Bn	6, 5	I/O	
EN	8	I	Enable input; connect to Vref_B and pull-up through a high resistor (200 kΩ). See <a href="#">Using the Enable Pin with the LSF Family</a>
GND	1	—	Ground
Vref_A	2	—	Reference supply voltage.
Vref_B	7	—	For proper device biasing, see <a href="#">Section 9</a> and <a href="#">Understanding the Bias Circuit for the LSF Family</a> .

(1) I = input, O = output



**Figure 5-5. LSF0102 YZT Package, 8-Pin DSBGA (Bottom View)**

Legend	
Input	Input or Output
Ground	

**Table 5-3. Pin Functions**

PIN		TYPE <sup>(1)</sup>	DESCRIPTION
YZT NO.	NAME		
C1	A1	I/O	Auto-Bidirectional Data port
D1	A2	I/O	
C2	B1	I/O	
D2	B2	I/O	
B1	Vref_A	—	Reference supply voltage. For proper device biasing, see <a href="#">Section 9</a> and <a href="#">Understanding the Bias Circuit for the LSF Family</a> .
B2	Vref_B	—	
A2	EN	I	Enable input; connect to Vref_B and pull-up through a high resistor (200 kΩ). See <a href="#">Using the Enable Pin with the LSF Family</a>
A1	GND	—	Ground

(1) I = input, O = output

Pinout drawings are not to scale

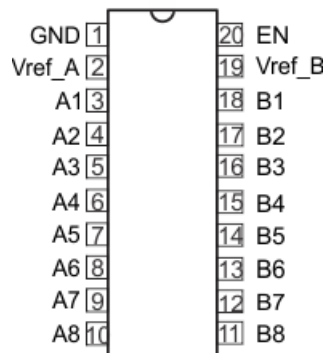

Figure 5-6. LSF0108 PW or DGS Package, 20-Pin TSSOP or VSSOP (Top View)

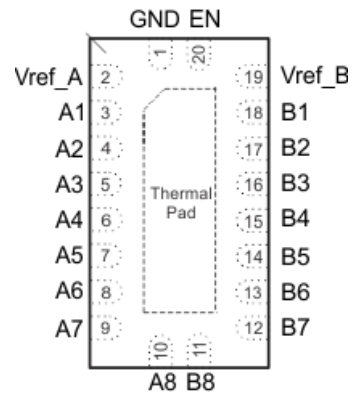

Figure 5-7. LSF0108 RKS Package, 20-Pin VQFN (Transparent Top View)

Table 5-4. Pin Functions

PIN		TYPE <sup>(1)</sup>	DESCRIPTION
NAME	PW, DGS RKS NO.		
An	3 to 10	I/O	Auto-Bidirectional Data port
Bn	18 to 11	I/O	
EN	20	I	Enable input; connect to Vref_B and pull-up through a high resistor (200 kΩ). See <a href="#">Using the Enable Pin with the LSF Family</a>
GND	1	—	Ground
Vref_A	2	—	Reference supply voltage.
Vref_B	19	—	For proper device biasing, see <a href="#">Section 9</a> and <a href="#">Understanding the Bias Circuit for the LSF Family</a> .

(1) I = input, O = output

## 6 Specifications

### 6.1 Absolute Maximum Ratings

over operating free-air temperature (unless otherwise noted)<sup>(1)</sup>

		MIN	MAX	UNIT
V <sub>I</sub>	Input voltage <sup>(2)</sup>	-0.5	7	V
V <sub>I/O</sub>	Input/output voltage <sup>(2)</sup>	-0.5	7	V
	Continuous channel current		128	mA
I <sub>IK</sub>	Input clamp current	V <sub>I</sub> < 0	-50	mA
T <sub>J</sub>	Junction Temperature		150	°C
T <sub>stg</sub>	Storage temperature range	-65	150	°C

- (1) Stresses beyond those listed under "absolute maximum ratings" may cause permanent damage to the device. These are stress ratings only, and functional operation of the device at these or any other conditions beyond those indicated under "recommended operating conditions" is not implied. Exposure to absolute-maximum-rated conditions for extended periods may affect device reliability.
- (2) The input and input/output negative-voltage ratings may be exceeded if the input and input/output clamp-current ratings are observed.

### 6.2 ESD Ratings

		VALUE	UNIT
V <sub>(ESD)</sub>	Electrostatic discharge	Human-body model (HBM), per ANSI/ESDA/JEDEC JS-001 <sup>(1)</sup>	±2000
		Charged-device model (CDM), per JEDEC specification JESD22-C101 <sup>(2)</sup>	±1000

- (1) JEDEC document JEP155 states that 500-V HBM allows safe manufacturing with a standard ESD control process. Manufacturing with less than 500-V HBM is possible with the necessary precautions.
- (2) JEDEC document JEP157 states that 250-V CDM allows safe manufacturing with a standard ESD control process. Manufacturing with less than 250-V CDM is possible with the necessary precautions.

### 6.3 Recommended Operating Conditions

over operating free-air temperature range (unless otherwise noted)

		MIN	MAX	UNIT
V <sub>I/O</sub>	Input/output voltage	0	5	V
V <sub>ref_A/B/EN</sub>	Reference voltage	0	5	V
I <sub>PASS</sub>	Pass transistor current		64	mA
T <sub>A</sub>	Operating free-air temperature	-40	125	°C

### 6.4 Thermal Information

THERMAL METRIC <sup>(1)</sup>	LSF0101		UNIT	
	DTQ (X2SON)	DRY (SON)		
	6 PINS	6 PINS		
R <sub>θJA</sub>	Junction-to-ambient thermal resistance	294.4	407.0	°C/W
R <sub>θJC(top)</sub>	Junction-to-case (top) thermal resistance	188.9	285.2	°C/W
R <sub>θJB</sub>	Junction-to-board thermal resistance	216.8	271.6	°C/W
ψ <sub>JT</sub>	Junction-to-top characterization parameter	26.5	113.5	°C/W
ψ <sub>JB</sub>	Junction-to-board characterization parameter	216.0	271.0	°C/W
R <sub>θJC(bot)</sub>	Junction-to-case (bottom) thermal resistance	n/a	n/a	°C/W

## 6.5 Thermal Information

THERMAL METRIC <sup>(1)</sup>		LSF0102					UNIT
		DCU (US8)	DCT (SM8)	DQE (X2SON)	YZT (DSBGA)	DDF (SOT-23)	
		8 PINS	8 PINS	8 PINS	8 PINS	8 PINS	
$R_{\theta JA}$	Junction-to-ambient thermal resistance	210.1	189.6	246.5	125.5	243.3	°C/W
$R_{\theta JC(top)}$	Junction-to-case (top) thermal resistance	89.1	119.6	149.1	1.0	168.7	°C/W
$R_{\theta JB}$	Junction-to-board thermal resistance	88.8	102.1	100.0	62.7	157.6	°C/W
$\Psi_{JT}$	Junction-to-top characterization parameter	8.3	44.5	17.1	3.4	45.9	°C/W
$\Psi_{JB}$	Junction-to-board characterization parameter	88.4	101.0	99.8	62.7	157.2	°C/W
$R_{\theta JC(bot)}$	Junction-to-case (bottom) thermal resistance	n/a	n/a	n/a	n/a	n/a	°C/W

(1) For more information about traditional and new thermal metrics, see the *IC Package Thermal Metrics* application report, [SPRA953](#).

## 6.6 Thermal Information

THERMAL METRIC <sup>(1)</sup>		LSF0108			UNIT
		RKS (VQFN)	PW (TSSOP)	DGS (VSSOP)	
		20 PINS	20 PINS	20 PINS	
$R_{\theta JA}$	Junction-to-ambient thermal resistance	49.3	106.6	123.0	°C/W
$R_{\theta JC(top)}$	Junction-to-case (top) thermal resistance	45.9	41.0	62.2	°C/W
$R_{\theta JB}$	Junction-to-board thermal resistance	20.6	57.6	77.4	°C/W
$\Psi_{JT}$	Junction-to-top characterization parameter	2.5	4.2	8.8	°C/W
$\Psi_{JB}$	Junction-to-board characterization parameter	20.6	47.0	77.0	°C/W
$R_{\theta JC(bot)}$	Junction-to-case (bottom) thermal resistance	3.4	n/a	n/a	°C/W

(1) For more information about traditional and new thermal metrics, see the *IC Package Thermal Metrics* application report, [SPRA953](#).



## 6.7 Electrical Characteristics

over recommended operating free-air temperature range (unless otherwise noted)

PARAMETER	TEST CONDITIONS		MIN	TYP <sup>(1)</sup>	MAX	UNIT
$V_{IK}$	$I_I = -18 \text{ mA}$ ,	$V_{EN} = 0$			-1.2	V
$I_{IH}$	$V_I = 5 \text{ V}$	$V_{EN} = 0$			5.0	$\mu\text{A}$
$I_{CC}$	$V_{ref\_B} = V_{EN} = 5.5 \text{ V}$ , $V_{ref\_A} = 4.5 \text{ V}$ , $I_O = 0$ , $V_I = V_{CC}$ or GND			6		$\mu\text{A}$
$C_{I(ref\_A/B/EN)}$	$V_I = 3 \text{ V}$ or 0			11		pF
$C_{io(off)}$	$V_O = 3 \text{ V}$ or 0,	$V_{EN} = 0$		4.0	6.0	pF
$C_{io(on)}$	$V_O = 3 \text{ V}$ or 0,	$V_{EN} = 3 \text{ V}$		10.5	12.5	pF
$r_{on}$ <sup>(2)</sup>	$V_I = 0$ ,	$I_O = 64 \text{ mA}$	$V_{ref\_A} = 3.3 \text{ V}$ ; $V_{ref\_B} = V_{EN} = 5 \text{ V}$		8.0	$\Omega$
			$V_{ref\_A} = 1.8 \text{ V}$ ; $V_{ref\_B} = V_{EN} = 5 \text{ V}$		9.0	
			$V_{ref\_A} = 1.0 \text{ V}$ ; $V_{ref\_B} = V_{EN} = 5 \text{ V}$		10	
	$V_I = 0$ ,	$I_O = 32 \text{ mA}$	$V_{ref\_A} = 1.8 \text{ V}$ ; $V_{ref\_B} = V_{EN} = 5 \text{ V}$		10	$\Omega$
			$V_{ref\_A} = 2.5 \text{ V}$ ; $V_{ref\_B} = V_{EN} = 5 \text{ V}$		15	
	$V_I = 1.8 \text{ V}$ ,	$I_O = 15 \text{ mA}$	$V_{ref\_A} = 3.3 \text{ V}$ ; $V_{ref\_B} = V_{EN} = 5 \text{ V}$		9.0	$\Omega$
	$V_I = 1.0 \text{ V}$ ,	$I_O = 10 \text{ mA}$	$V_{ref\_A} = 1.8 \text{ V}$ ; $V_{ref\_B} = V_{EN} = 3.3 \text{ V}$		18	$\Omega$
	$V_I = 0 \text{ V}$ ,	$I_O = 10 \text{ mA}$	$V_{ref\_A} = 1.0 \text{ V}$ ; $V_{ref\_B} = V_{EN} = 3.3 \text{ V}$		20	$\Omega$
$V_I = 0 \text{ V}$ ,	$I_O = 10 \text{ mA}$	$V_{ref\_A} = 1.0 \text{ V}$ ; $V_{ref\_B} = V_{EN} = 1.8 \text{ V}$		30	$\Omega$	

(1) All typical values are at  $T_A = 25^\circ\text{C}$ .

(2) Measured by the voltage drop between the A and B pins at the indicated current through the switch. On-state resistance is determined by the lowest voltage of the two (A or B) pins.

## 6.8 LSF0101/02 AC Performance (Translating Down) Switching Characteristics, $V_{GATE} = 3.3 \text{ V}$

over recommended operating free-air temperature range,  $V_{GATE} = 3.3 \text{ V}$ ,  $V_{IH} = 3.3 \text{ V}$ ,  $V_{IL} = 0$ , and  $V_M = 1.15 \text{ V}$  (unless otherwise noted) (see [Figure 7-1](#))

PARAMETER	FROM (INPUT)	TO (OUTPUT)	$C_L = 50 \text{ pF}$		$C_L = 30 \text{ pF}$		$C_L = 15 \text{ pF}$		UNIT
			TYP	MAX	TYP	MAX	TYP	MAX	
$t_{PLH}$	A or B	B or A	1.1		0.7		0.3		ns
$t_{PHL}$			1.2		0.8		0.4		

## 6.9 LSF0108 AC Performance (Translating Down) Switching Characteristics, $V_{GATE} = 3.3 \text{ V}$

over recommended operating free-air temperature range,  $V_{GATE} = 3.3 \text{ V}$ ,  $V_{IH} = 3.3 \text{ V}$ ,  $V_{IL} = 0$ , and  $V_M = 1.15 \text{ V}$  (unless otherwise noted) (see [Figure 7-1](#))

PARAMETER	FROM (INPUT)	TO (OUTPUT)	$C_L = 50 \text{ pF}$		$C_L = 30 \text{ pF}$		$C_L = 15 \text{ pF}$		UNIT
			TYP	MAX	TYP	MAX	TYP	MAX	
$t_{PLH}$	A or B	B or A	1.9		1.4		0.75		ns
$t_{PHL}$			2		1.5		0.85		

## 6.10 LSF0101/02 AC Performance (Translating Down) Switching Characteristics, $V_{GATE} = 2.5 \text{ V}$

over recommended operating free-air temperature range,  $V_{GATE} = 2.5 \text{ V}$ ,  $V_{IH} = 2.5 \text{ V}$ ,  $V_{IL} = 0$ , and  $V_M = 0.75 \text{ V}$  (unless otherwise noted) (see [Figure 7-1](#))

PARAMETER	FROM (INPUT)	TO (OUTPUT)	$C_L = 50 \text{ pF}$		$C_L = 30 \text{ pF}$		$C_L = 15 \text{ pF}$		UNIT
			TYP	MAX	TYP	MAX	TYP	MAX	
$t_{PLH}$	A or B	B or A	1.2		0.8		0.35		ns
$t_{PHL}$			1.3		1		0.5		

### 6.11 LSF0108 AC Performance (Translating Down) Switching Characteristics, $V_{GATE} = 2.5\text{ V}$

over recommended operating free-air temperature range,  $V_{GATE} = 2.5\text{ V}$ ,  $V_{IH} = 2.5\text{ V}$ ,  $V_{IL} = 0$ , and  $V_M = 0.75\text{ V}$  (unless otherwise noted) (see [Figure 7-1](#))

PARAMETER	FROM (INPUT)	TO (OUTPUT)	$C_L = 50\text{ pF}$		$C_L = 30\text{ pF}$		$C_L = 15\text{ pF}$		UNIT
			TYP	MAX	TYP	MAX	TYP	MAX	
$t_{PLH}$	A or B	B or A	2		1.45		0.8		ns
$t_{PHL}$			2.1		1.55		0.9		

### 6.12 LSF0101/02 AC Performance (Translating Up) Switching Characteristics, $V_{GATE} = 3.3\text{ V}$

over recommended operating free-air temperature range,  $V_{GATE} = 3.3\text{ V}$ ,  $V_{IH} = 2.3\text{ V}$ ,  $V_{IL} = 0$ ,  $V_T = 3.3\text{ V}$ ,  $V_M = 1.15\text{ V}$  and  $R_L = 300$  (unless otherwise noted) (see [Figure 7-1](#))

PARAMETER	FROM (INPUT)	TO (OUTPUT)	$C_L = 50\text{ pF}$		$C_L = 30\text{ pF}$		$C_L = 15\text{ pF}$		UNIT
			TYP	MAX	TYP	MAX	TYP	MAX	
$t_{PLH}$	A or B	B or A	1		0.8		0.4		ns
$t_{PHL}$			1		0.9		0.4		

### 6.13 LSF0108 AC Performance (Translating Up) Switching Characteristics, $V_{GATE} = 3.3\text{ V}$

over recommended operating free-air temperature range,  $V_{GATE} = 3.3\text{ V}$ ,  $V_{IH} = 2.3\text{ V}$ ,  $V_{IL} = 0$ ,  $V_T = 3.3\text{ V}$ ,  $V_M = 1.15\text{ V}$  and  $R_L = 300$  (unless otherwise noted) (see [Figure 7-1](#))

PARAMETER	FROM (INPUT)	TO (OUTPUT)	$C_L = 50\text{ pF}$		$C_L = 30\text{ pF}$		$C_L = 15\text{ pF}$		UNIT
			TYP	MAX	TYP	MAX	TYP	MAX	
$t_{PLH}$	A or B	B or A	2.1		1.55		0.9		ns
$t_{PHL}$			2.2		1.65		1		

### 6.14 LSF0101/02 AC Performance (Translating Up) Switching Characteristics, $V_{GATE} = 2.5\text{ V}$

over recommended operating free-air temperature range,  $V_{GATE} = 2.5\text{ V}$ ,  $V_{IH} = 1.5\text{ V}$ ,  $V_{IL} = 0$ ,  $V_T = 2.5\text{ V}$ ,  $V_M = 0.75\text{ V}$  and  $R_L = 300$  (unless otherwise noted) (see [Figure 7-1](#))

PARAMETER	FROM (INPUT)	TO (OUTPUT)	$C_L = 50\text{ pF}$		$C_L = 30\text{ pF}$		$C_L = 15\text{ pF}$		UNIT
			TYP	MAX	TYP	MAX	TYP	MAX	
$t_{PLH}$	A or B	B or A	1.1		0.9		0.45		ns
$t_{PHL}$			1.3		1.1		0.6		

### 6.15 LSF0108 AC Performance (Translating Up) Switching Characteristics, $V_{GATE} = 2.5\text{ V}$

over recommended operating free-air temperature range,  $V_{GATE} = 2.5\text{ V}$ ,  $V_{IH} = 1.5\text{ V}$ ,  $V_{IL} = 0$ ,  $V_T = 2.5\text{ V}$ ,  $V_M = 0.75\text{ V}$  and  $R_L = 300$  (unless otherwise noted) (see [Figure 7-1](#))

PARAMETER	FROM (INPUT)	TO (OUTPUT)	$C_L = 50\text{ pF}$		$C_L = 30\text{ pF}$		$C_L = 15\text{ pF}$		UNIT
			TYP	MAX	TYP	MAX	TYP	MAX	
$t_{PLH}$	A or B	B or A	1.8		1.35		0.8		ns
$t_{PHL}$			1.9		1.45		0.9		

## 6.16 Typical Characteristics

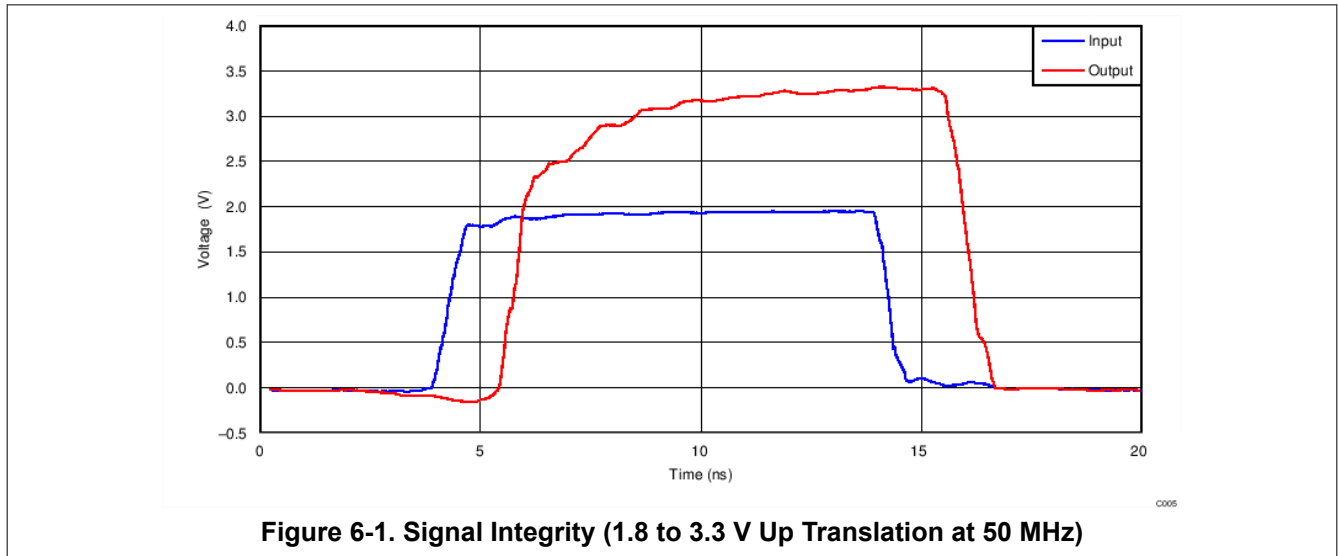

## 7 Parameter Measurement Information

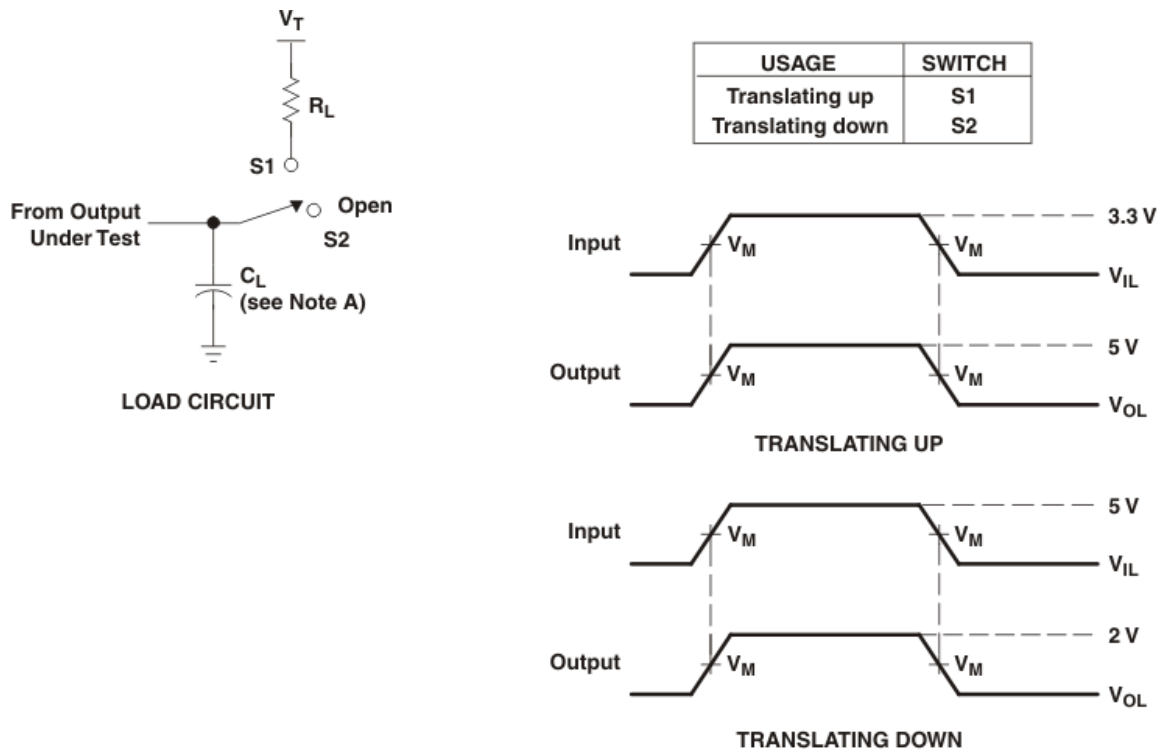

- NOTES: A.  $C_L$  includes probe and jig capacitance.  
 B. All input pulses are supplied by generators having the following characteristics:  $PRR \leq 10\text{ MHz}$ ,  $Z_O = 50\ \Omega$ ,  $t_r \leq 2\text{ ns}$ ,  $t_f \leq 2\text{ ns}$ .  
 C. The outputs are measured one at a time, with one transition per measurement.

**Figure 7-1. Load Circuit for Outputs**

## 8 Detailed Description

### 8.1 Overview

The LSF family can be used in level-translation applications for interfacing devices or systems operating with one another that operate at different interface voltages. The LSF family is ideal for use in applications where an open-drain driver is connected to the data I/Os. With appropriate pull-up resistors and layout, LSF can achieve 100 MHz. The LSF family can also be used in applications where a push-pull driver is connected to the data I/Os. For an overview of device setup and operation, see [The Logic Minute](#) training series on [Understanding the LSF Family of Bidirectional, Multi-Voltage Level Translators](#).

### 8.2 Functional Block Diagram

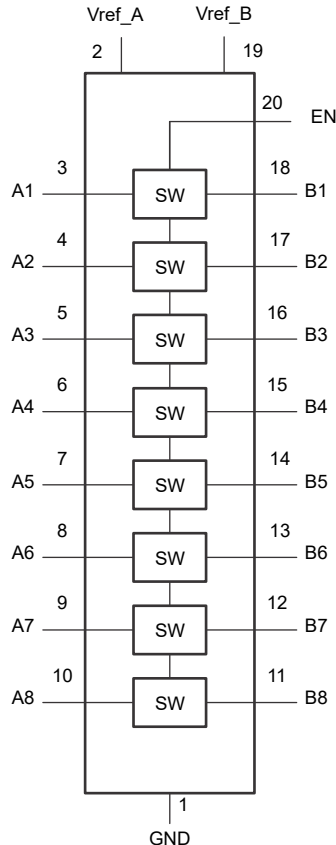

### 8.3 Feature Description

#### 8.3.1 Auto Bidirectional Voltage Translation

All devices in the LSF family are auto bidirectional voltage level translators that are operational from 0.95 to 4.5 V on the Vref\_A supply and from 1.8 to 5.5 V on the Vref\_B supply. This allows bidirectional voltage translation between 0.95 V and 5.5 V without the need for a direction pin in open-drain or push-pull applications. The LSF family supports level translation applications with transmission speeds greater than 100 Mbps for open-drain systems using a 30-pF capacitance and 250-Ω pullup resistor. Both the output driver of the controller and the peripheral device output can be push-pull or open-drain (pull-up resistors may be required). In both up and down translation, the B-side is often referred to as the high side and refers to devices connected to the B ports. The A-side can be referred to as the low side.

### 8.3.2 Output Enable

To enable the I/O pins, the EN input should be tied directly to Vref\_B during operation and both pins must be pulled up to the HIGH side (Vpu or VCCB) through a pull-up resistor (typically 200 kΩ). To ensure the high impedance state during power-up, power-down, or during operation, the EN pin must be LOW. The EN pin should always be tied directly to the Vref\_B pin and is recommended to be disabled by an open-drain driver without a pullup resistor. This allows Vref\_B to regulate the EN input and bias the channels for proper translation. A filter capacitor on Vref\_B is recommended for a stable supply at the device.

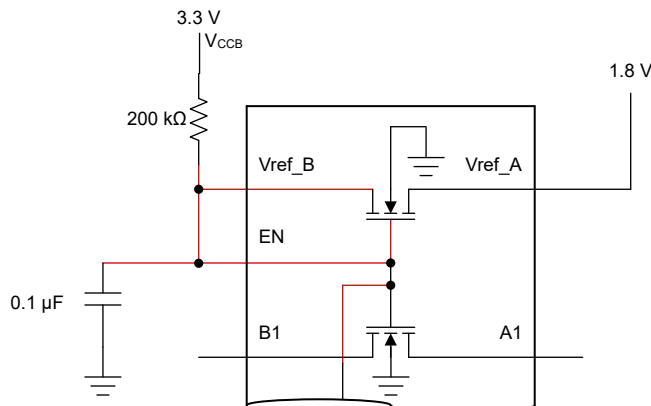

**Figure 8-1. Enable Pin Tied to Vref\_B Directly and to VCCB Through a Pull-Up Resistor**

The supply voltage of open drain I/O devices can be completely different from the supplies used for the LSF and has no impact on the operation. For additional details on how to use the enable pin, see the [Using the Enable Pin with the LSF Family video](#).

**Table 8-1. Enable Pin Function Table**

INPUT EN <sup>(1)</sup> PIN	Data Port State
Tied directly to Vref_B	An = Bn
L	Hi-Z

(1) EN is controlled by Vref\_B logic levels.

### 8.4 Device Functional Modes

For each channel (n), when either the An or Bn port is LOW, the switch provides a low impedance path between the An and Bn ports; the corresponding Bn or An port will be pulled LOW. The low RON of the switch allows connections to be made with minimal propagation delay and signal distortion.

Table 8-1 provides a summary of device operation. For additional details on the functional operation of the LSF family of devices, see the [Down Translation with the LSF Family](#) and [Up Translation with the LSF Family](#) videos.

**Table 8-2. Device Functionality**

Signal Direction <sup>(1)</sup>	Input State	Switch State	Functionality
B to A (Down Translation)	B = LOW	ON (Low Impedance)	A-side voltage is pulled low through the switch to the B-side voltage
	B = HIGH	OFF (High Impedance)	A-side voltage is clamped at Vref_A <sup>(2)</sup>
A to B (Up Translation)	A = LOW	ON (Low Impedance)	B-side voltage is pulled low through the switch to the A-side voltage
	A = HIGH	OFF (High Impedance)	B-side voltage is clamped at Vref_A and then pulled up to the Vpu# supply voltage

(1) The downstream channel should not be actively driven through a low impedance driver, or else bus contention may occur.

(2) The A-side can have a pullup to Vref\_A for additional current drive capability or may also be pulled above Vref\_A with a pullup resistor. Specifications in the [Recommended Operating Conditions](#) section should always be followed.

## 8.4.1 Up and Down Translation

### Up Translation:

When the signal is being driven from A to B and the An port is HIGH, the switch will be OFF and the Bn port will then be driven to a voltage higher than Vref\_A by the pullup resistor that is connected to the pull-up supply voltage (Vpu#). This functionality allows seamless translation between higher and lower voltages selected by the user, without the need for directional control. Pull-up resistors are always required on the high side, and pull-ups are only required on the low side if the low side device's output is open drain or its input has a leakage greater than 1  $\mu$ A.

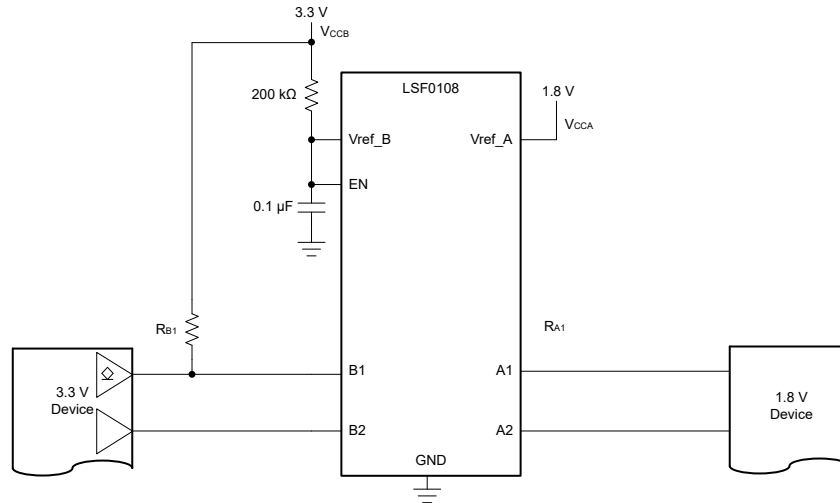

Figure 8-2. Up Translation Example Schematic with Push-Pull and Open Drain Configuration

Up translation with the LSF requires attention to two important factors: maximum data rate and sink current. Maximum data rate is directly related to the rising edge of the output signal. Sink current depends on supply values and the chosen pull-up resistor values. Equation 1 below shows the maximum data rate formula and equation 2 presents the maximum sink current formula, both of which are estimations. A low RC value is needed to reach high speeds, which also require strong drivers. Please see the [Up Translation with the LSF Family](#) video for estimated data rate and sink current calculations based on circuit components.

### Down Translation:

$$\frac{1}{3 \times 2R_{B1}C_{B1}} = \frac{1}{6R_{B1}C_{B1}} \left( \frac{\text{bits}}{\text{second}} \right) \quad (1)$$

$$I_{OL} \cong \frac{V_{CCA}}{R_{A1}} + \frac{V_{CCB}}{R_{B1}} \quad (A) \quad (2)$$

When the signal is being driven HIGH from the Bn port to An port, the switch will be OFF, clamping the voltage on the An port to the voltage set by Vref\_A. A pull-up resistor can be added on either side of the device. There are special circumstances that allow the removal of one or both of the pull-up resistors. If the signal is always going to be down translated from a push-pull transmitter, then the resistor on the B-side can be removed. If the leakage current into the receiver on the A-side is less than 1  $\mu$ A, then the resistor on the A-side can also be removed. This arrangement with no external pull-up resistors can be used when down translating from a push-pull output to a low-leakage input. For an open drain transmitter, the pull-up resistor on the B-side is necessary because an open drain output can't drive high by itself. Refer to Table 8-2 for a summary of device operation. For additional details on the functional operation of the LSF family of devices, see the [Up Translation with the LSF Family](#) and [Down Translation with the LSF Family](#) videos.

## 9 Application and Implementation

### Note

Information in the following applications sections is not part of the TI component specification, and TI does not warrant its accuracy or completeness. TI's customers are responsible for determining suitability of components for their purposes, as well as validating and testing their design implementation to confirm system functionality.

### 9.1 Application Information

The LSF devices are able to perform voltage translation for open-drain or push-pull interfaces. [Table 9-1](#) provides common interfaces and the corresponding device recommendation from the LSF family which supports the corresponding bit count.

**Table 9-1. Voltage Translator for Common Interfaces**

Part Name	Channel Number	Interface
LSF0101	1	GPIO
LSF0102	2	GPIO, MDIO, SMBus, PMBus, and I <sup>2</sup> C
LSF0108	8	GPIO, MDIO, SDIO, SVID, UART, SMBus, PMBus, I <sup>2</sup> C, and SPI

Please find below some important reminders regarding the LSF family of devices:

- LSF devices are switch-based, not buffer-based (please see the TXB family for buffer-based devices).
- Specific data rates cannot be calculated by using  $1/T_{pd}$ .
- VCCB/VCCA are not the same as Vref\_B or Vref\_A: VCCB refers to the B-side supply voltage supplied to the LSF device, while Vref\_B refers to the voltage at the Vref\_B pin (pin 7 of Figure 9-1.) on the other side of the 200k resistor.

### 9.2 Typical Applications

#### 9.2.1 Open-Drain Interface (I<sup>2</sup>C, PMBus, SMBus, and GPIO)

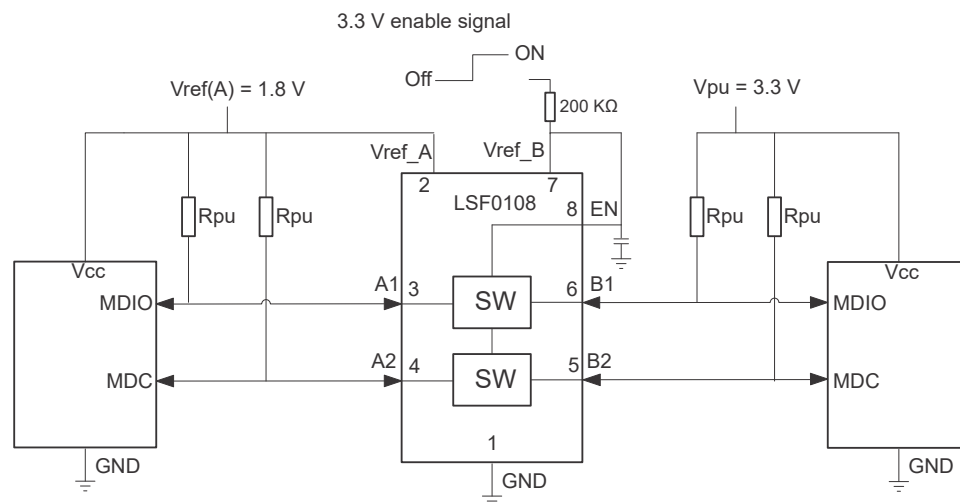

**Figure 9-1. Typical Application Circuit for Open-Drain Translation (MDIO Shown as an Example)**



### 9.2.1.1 Design Requirements

#### 9.2.1.1.1 Enable, Disable, and Reference Voltage Guidelines

When Vref\_B is connected through a 200-kΩ resistor to a 3.3-V Vpu power supply and Vref\_A is set 1.8 V, as shown in Figure 9-1, the A1 and A2 channels have a maximum output voltage equal to Vref\_A, and the B1 and B2 channels have a maximum output voltage equal to Vpu.

The LSF family has an EN input that is used to disable the device by setting EN LOW, placing all I/Os in the high-impedance state. Since the LSF family of devices are switch-type voltage translators, the power consumption is very low. TI recommends always enabling the LSF family for bidirectional applications (I<sup>2</sup>C, SMBus, PMBus, or MDIO).

**Table 9-2. Application Operating Condition**

PARAMETER		MIN	TYP	MAX	UNIT
Vref_A <sup>(1)</sup>	reference voltage (A)	0.95		5.0	V
Vref_B	reference voltage (B)	Vref_A + 0.8		5.0	V
V <sub>I(EN)</sub>	input voltage on EN pin	Vref_A + 0.8		5.0	V
Vpu	pull-up supply voltage	0		Vref_B	V

(1) Vref\_A is required to be the lowest voltage level across all inputs and outputs.

#### Note

The 200 kΩ, pull-up resistor is required to allow Vref\_B to regulate the EN input and properly bias the device for translation.

#### 9.2.1.1.2 Bias Circuitry

For proper operation, VCCA must always be at least 0.8 V less than VCCB ( $VCCA + 0.8 \leq VCCB$ ). The 200 kΩ pull-up resistor is required to allow Vref\_B to regulate the EN input and properly bias the device for translation. A 0.1 μF capacitor is recommended for providing a path from Vref\_B to ground for high frequency noise. Vref\_B and V<sub>I</sub>(EN) are recommended to be 1.0 V higher than Vref\_A for best signal integrity.

Attempting to drive the EN pin directly with a push-pull output device is a very common design error with the LSF01 series of devices. It is also very important to note that current does flow into the A-side voltage supply during normal operation. Not all voltage sources can sink current, so be sure that applicable designs can handle this current. For more design details, see the [Understanding the Bias Circuit for the LSF Family](#) video.

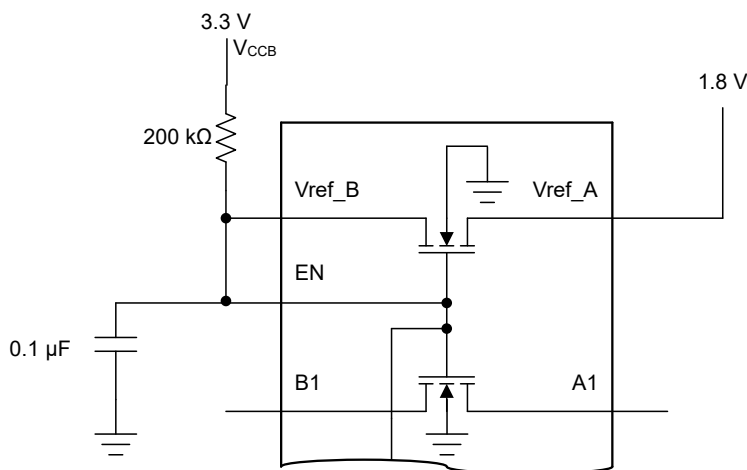

**Figure 9-2. Bias Circuitry Inside the LSF0108 Devices**

### 9.2.1.2 Detailed Design Procedure

#### 9.2.1.2.1 Bidirectional Translation

For the bidirectional translation configuration (higher voltage to lower voltage or lower voltage to higher voltage), the EN input must be connected to Vref\_B and both pins must be pulled up to the HIGH side Vpu through a pull-up resistor (typically 200 kΩ). This allows Vref\_B to regulate the EN input and bias the channels for proper translation. A filter capacitor on Vref\_B is recommended for a stable supply at the device. The controller output driver can be push-pull or open-drain (pull-up resistors may be required) and the peripheral device output can be push-pull or open-drain (pull-up resistors are required to pull the Bn outputs to Vpu).

#### Note

If either output is push-pull, data must be unidirectional or the outputs must be tri-state and be controlled by some direction-control mechanism to prevent HIGH-to-LOW bus contention in either direction. If both outputs are open-drain, no direction control is needed.

#### 9.2.1.2.2 Pull-Up Resistor Sizing

The pull-up resistor value needs to limit the current through the pass transistor when it is in the ON state to about 15 mA. This ensures a voltage drop of 260 mV to 350 mV to have a valid LOW signal on the downstream channel. If the current through the pass transistor is higher than 15 mA, the voltage drop is also higher in the ON state. To set the current through each pass transistor at 15 mA, calculate the pull-up resistor value using the following equation:

$$R_{pu} = \frac{(V_{pu} - 0.35 \text{ V})}{0.015 \text{ A}} \quad (3)$$

Table 9-3 summarizes resistor values, reference voltages, and currents at 8 mA, 5 mA, and 3 mA. The resistor value shown in the +10% column (or a larger value) should be used to ensure that the voltage drop across the transistor is 350 mV or less. The external driver must be able to sink the total current from the resistors on both sides of the LSF family device at 0.175 V, although the 15 mA applies only to current flowing through the LSF family device. The device driving the low state at 0.175 V must sink current from one or more of the pull-up resistors and maintain VOL. A decrease in resistance will increase current, and thus result in increased VOL.

**Table 9-3. Pull-Up Resistor Values**

V <sub>DPU</sub> <sup>(1) (2)</sup>	8 mA		5 mA		3 mA	
	NOMINAL (Ω)	+10% <sup>(3)</sup> (Ω)	NOMINAL (Ω)	+10% <sup>(3)</sup> (Ω)	NOMINAL (Ω)	+10% <sup>(3)</sup> (Ω)
5 V	581	639	930	1023	1550	1705
3.3 V	369	406	590	649	983	1082
2.5 V	269	296	430	473	717	788
1.8 V	181	199	290	319	483	532
1.5 V	144	158	230	253	383	422
1.2 V	106	117	170	187	283	312

- (1) Calculated for V<sub>OL</sub> = 0.35 V  
(2) Assumes output driver V<sub>OL</sub> = 0.175 V at stated current  
(3) +10% to compensate for V<sub>DD</sub> range and resistor tolerance

### 9.2.1.3 Application Curve

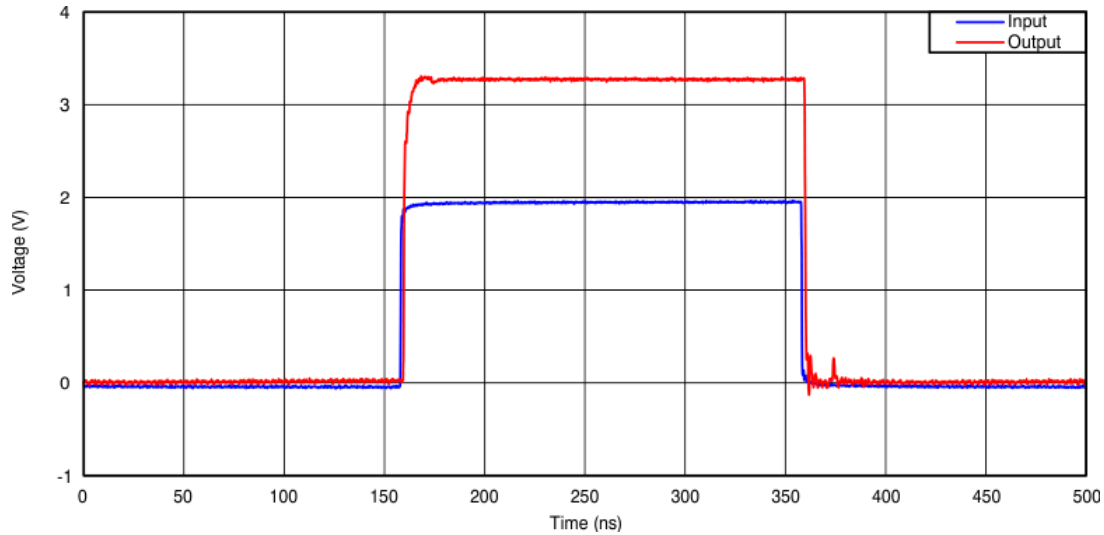

**Figure 9-3. Open Drain Translation (1.8 V to 3.3 V at 2.5 MHz)**

### 9.2.2 Mixed-Mode Voltage Translation

The supply voltage ( $V_{pu\#}$ ) for each channel can be individually set with a pull-up resistor. [Figure 9-4](#) shows an example of this mixed-mode multi-voltage translation. For additional details on multi-voltage translation, see the [Multi-voltage Translation with the LSF Family](#) video.

With the  $V_{ref\_B}$  pulled up to 5 V and  $V_{ref\_A}$  connected to 1.8 V, all channels will be clamped to 1.8 V at which point a pullup can be used to define the high level voltage for a given channel.

- **Push-Pull Down Translation (5 V to 1.8 V):** Channel 1 is an example of this setup. When B1 is 5 V, A1 is clamped to 1.8 V, and when B1 is LOW, A1 is driven LOW through the switch.
- **Push-Pull Up Translation (1.8 V to 5 V):** Channel 2 is an example of this setup. When A2 is 1.8 V, the switch is high impedance and the B2 channel is pulled up to 5 V. When A2 is LOW, B2 is driven LOW through the switch.
- **Push-Pull Down Translation (3.3 V to 1.8 V):** Channels 3 and 4 are examples of this setup. When either B3 or B4 are driven to 3.3 V, A3 or A4 are clamped to 1.8 V, and when either B3 or B4 are LOW, A3 or A4 are driven LOW through the switch.
- **Open-Drain Bidirectional Translation (3.3 V ↔ 1.8 V):** Channels 5 through 8 are examples of this setup. These channels are for bidirectional operation for I<sup>2</sup>C and MDIO to translate between 1.8 V and 3.3 V with open-drain drivers.



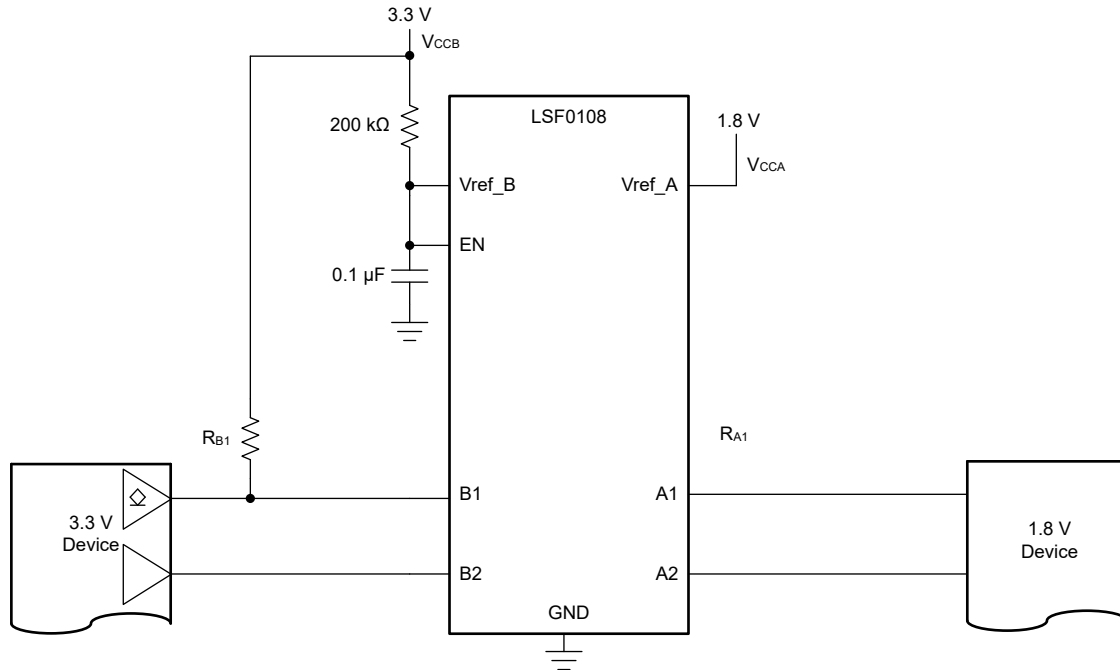

**Figure 9-5. Single Supply Translation with 3.3 V Supply**

The steps to select the resistor values for R1 and R2 are as follows:

1. Select a value for R1. Typically, 1 MΩ is used to reduce current consumption.
2. Plug in values for your system into the the following equation. Note that Vref\_A is the lowest voltage in the system. VCCB is the primary supply and R1 is the selected value from step 1.

$$R_2 = \frac{200 \left(10^3\right) \times R_1 \times V_{REFA}}{\left(200 \left(10^3\right) + R_1\right) \left(V_{CCB} - V_{REFA}\right) - 0.85 \times R_1} \quad (4)$$

The single supply used must be at least 0.8 V larger than the lowest desired translation voltage. The voltage at Vref\_A must be selected as the lowest voltage to be used in the system. The LSF evaluation module (LSF-EVM) contains unpopulated pads to place R1 and R2 for single supply operation testing. For an example single supply translation schematic and details, see the [Single Supply Translation with the LSF Family](#) video.

### 9.2.4 Voltage Translation for $V_{ref\_B} < V_{ref\_A} + 0.8\text{ V}$

As described in the *Enable, Disable, and Reference Voltage Guidelines* section, it is generally recommended that  $V_{ref\_B} > V_{ref\_A} + 0.8\text{ V}$ ; however, the device can still operate in the condition where  $V_{ref\_B} < V_{ref\_A} + 0.8\text{ V}$  as long as additional considerations are made for the design.

**Typical Operation ( $V_{ref\_B} > V_{ref\_A} + 0.8\text{ V}$ ):** in this scenario, pullup resistors are not required on the A-side for proper down-translation as is shown for channels 1 and 2 of [Figure 9-4](#). The typical operating mode of the device ensures that when down translating from B to A, the A-side I/O ports will clamp at  $V_{ref\_A}$  to provide proper voltage translation. For further explanation of device operation, see the [Down Translation with the LSF Family](#) video.

**Requirements for  $V_{ref\_B} < V_{ref\_A} + 0.8\text{ V}$  Operation:** in this scenario, there is not a large enough voltage difference between  $V_{ref\_A}$  and  $V_{ref\_B}$  to ensure that the A side I/O ports will be clamped at  $V_{ref\_A}$ , but rather at a voltage approximately equal to  $V_{ref\_B} - 0.8\text{ V}$ . For example, if  $V_{ref\_B} = 1.8\text{ V}$  and  $V_{ref\_A} = 1.2\text{ V}$ , the A-side I/Os will clamp to a voltage around  $1.0\text{ V}$ . Therefore, to operate in such a condition, the following additional design considerations must be met:

- $V_{ref\_B}$  must be greater than  $V_{ref\_A}$  during operation ( $V_{ref\_B} > V_{ref\_A}$ )
- Pullup resistors should be populated on A-side I/O ports to ensure the line will be fully pulled up to the desired voltage

[Figure 9-6](#) shows an example of this setup, where  $1.2\text{ V} \leftrightarrow 1.8\text{ V}$  translation is achieved with the LSF0108. This type of setup also applies for other voltage nodes such as  $1.8\text{ V} \leftrightarrow 2.5\text{ V}$ ,  $1.05\text{ V} \leftrightarrow 1.5\text{ V}$ , and others as long as the *Recommended Operating Conditions* table is followed.

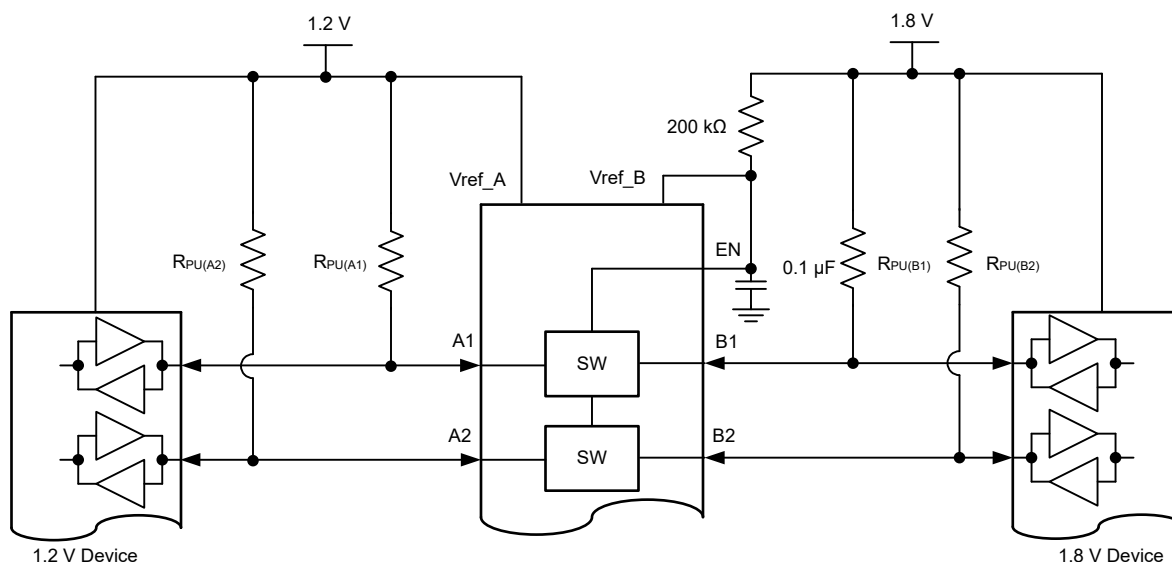

**Figure 9-6. 1.2 V to 1.8 V Level Translation with LSF0108**

## 10 Power Supply Recommendations

There are no power sequence requirements for the LSF family. [Table 10-1](#) provides recommended operating voltages for all supply and input pins.

**Table 10-1. Recommended Operating Voltages**

PARAMETER		MIN	TYP	MAX	UNIT
Vref_A <sup>(1)</sup>	reference voltage (A)	0.95		5.0	V
Vref_B	reference voltage (B)	Vref_A + 0.8		5.0	V
V <sub>I(EN)</sub>	input voltage on EN pin	Vref_A + 0.8		5.0	V
V <sub>pu</sub>	pull-up supply voltage	0		Vref_B	V

(1) Vref\_A is required to be the lowest voltage level across all inputs and outputs.

## 11 Layout

### 11.1 Layout Guidelines

Because the LSF family is a switch-type level translator, the signal integrity is highly related with a pull-up resistor and PCB capacitance condition.

- Short signal trace as possible to reduce capacitance and minimize stub from pull-up resistor.
- Place LSF close to high voltage side.
- Select the appropriate pull-up resistor that applies to translation levels and driving capability of transmitter.

### 11.2 Layout Example

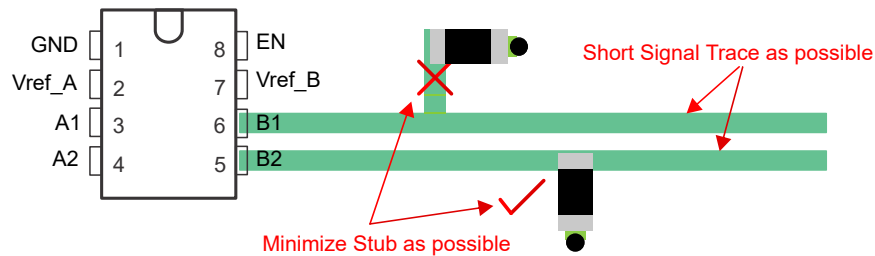

**Figure 11-1. Short Trace Layout**

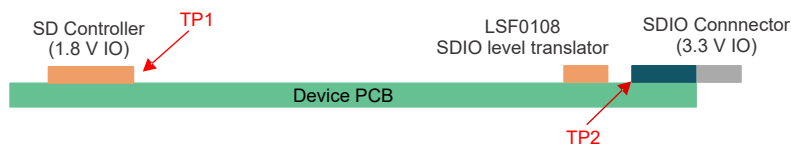

**Figure 11-2. Device Placement**

## 12 Device and Documentation Support

### 12.1 Related Documentation

For related documentation, see the following:

- Texas Instruments, [LSF Translator Family Evaluation Module user's guide](#)
- Texas Instruments, [Biasing Requirements for TXS, TXB, and LSF Auto-Bidirectional Translators application note](#)
- Texas Instruments, [Voltage Level Translation with the LSF Family application note](#)
- The Logic Minute Video Training Series on Understanding the LSF Family of Devices:
  - Texas Instruments, [Introduction - Voltage Level Translation with the LSF Family](#)
  - Texas Instruments, [Understanding the Bias Circuit for the LSF Family](#)
  - Texas Instruments, [Using the Enable Pin with the LSF Family](#)
  - Texas Instruments, [Translation Basics with the LSF Family](#)
  - Texas Instruments, [Down Translation with the LSF Family](#)
  - Texas Instruments, [Up Translation with the LSF Family](#)
  - Texas Instruments, [Multi-Voltage Translation with the LSF Family](#)
  - Texas Instruments, [Single Supply Translation with the LSF Family](#)

### 12.2 Receiving Notification of Documentation Updates

To receive notification of documentation updates, navigate to the device product folder on [ti.com](#). Click on [Subscribe to updates](#) to register and receive a weekly digest of any product information that has changed. For change details, review the revision history included in any revised document.

### 12.3 Support Resources

[TI E2E™ support forums](#) are an engineer's go-to source for fast, verified answers and design help — straight from the experts. Search existing answers or ask your own question to get the quick design help you need.

Linked content is provided "AS IS" by the respective contributors. They do not constitute TI specifications and do not necessarily reflect TI's views; see TI's [Terms of Use](#).

### 12.4 Trademarks

TI E2E™ is a trademark of Texas Instruments.

All trademarks are the property of their respective owners.

### 12.5 Electrostatic Discharge Caution



This integrated circuit can be damaged by ESD. Texas Instruments recommends that all integrated circuits be handled with appropriate precautions. Failure to observe proper handling and installation procedures can cause damage.

ESD damage can range from subtle performance degradation to complete device failure. Precision integrated circuits may be more susceptible to damage because very small parametric changes could cause the device not to meet its published specifications.

### 12.6 Glossary

[TI Glossary](#) This glossary lists and explains terms, acronyms, and definitions.

## 13 Mechanical, Packaging, and Orderable Information

The following pages include mechanical, packaging, and orderable information. This information is the most current data available for the designated devices. This data is subject to change without notice and revision of this document. For browser-based versions of this data sheet, refer to the left-hand navigation.



**PACKAGING INFORMATION**

Orderable Device	Status (1)	Package Type	Package Drawing	Pins	Package Qty	Eco Plan (2)	Lead finish/ Ball material (6)	MSL Peak Temp (3)	Op Temp (°C)	Device Marking (4/5)	Samples
LSF0101DRYR	ACTIVE	SON	DRY	6	5000	RoHS & Green	NIPDAU	Level-1-260C-UNLIM	-40 to 125	VD	<a href="#">Samples</a>
LSF0101DTQR	ACTIVE	X2SON	DTQ	6	3000	RoHS & Green	NIPDAU	Level-1-260C-UNLIM	-40 to 125	FC	<a href="#">Samples</a>
LSF0102DCTR	ACTIVE	SM8	DCT	8	3000	RoHS & Green	NIPDAU	Level-1-260C-UNLIM	-40 to 125	NG2 (S, Y)	<a href="#">Samples</a>
LSF0102DCUR	ACTIVE	VSSOP	DCU	8	3000	RoHS & Green	NIPDAU   SN	Level-1-260C-UNLIM	-40 to 125	(G2, NG2J, NG2P, N G2S) NY	<a href="#">Samples</a>
LSF0102DDFR	ACTIVE	SOT-23-THIN	DDF	8	3000	RoHS & Green	SN	Level-1-260C-UNLIM	-40 to 125	F0102	<a href="#">Samples</a>
LSF0102DQER	ACTIVE	X2SON	DQE	8	5000	RoHS & Green	NIPDAU	Level-1-260C-UNLIM	-40 to 125	RV	<a href="#">Samples</a>
LSF0102YZTR	ACTIVE	DSBGA	YZT	8	3000	RoHS & Green	SNAGCU	Level-1-260C-UNLIM	-40 to 125	RV	<a href="#">Samples</a>
LSF0108DGSR	ACTIVE	VSSOP	DGS	20	5000	RoHS & Green	NIPDAU	Level-1-260C-UNLIM	-40 to 125	LSF08	<a href="#">Samples</a>
LSF0108PWR	ACTIVE	TSSOP	PW	20	2000	RoHS & Green	SN	Level-1-260C-UNLIM	-40 to 125	LSF0108	<a href="#">Samples</a>
LSF0108RKSR	ACTIVE	VQFN	RKS	20	3000	RoHS & Green	NIPDAUAG	Level-1-260C-UNLIM	-40 to 125	LSF0108	<a href="#">Samples</a>

(1) The marketing status values are defined as follows:

**ACTIVE:** Product device recommended for new designs.

**LIFEBUY:** TI has announced that the device will be discontinued, and a lifetime-buy period is in effect.

**NRND:** Not recommended for new designs. Device is in production to support existing customers, but TI does not recommend using this part in a new design.

**PREVIEW:** Device has been announced but is not in production. Samples may or may not be available.

**OBSOLETE:** TI has discontinued the production of the device.

(2) **RoHS:** TI defines "RoHS" to mean semiconductor products that are compliant with the current EU RoHS requirements for all 10 RoHS substances, including the requirement that RoHS substance do not exceed 0.1% by weight in homogeneous materials. Where designed to be soldered at high temperatures, "RoHS" products are suitable for use in specified lead-free processes. TI may reference these types of products as "Pb-Free".

**RoHS Exempt:** TI defines "RoHS Exempt" to mean products that contain lead but are compliant with EU RoHS pursuant to a specific EU RoHS exemption.

**Green:** TI defines "Green" to mean the content of Chlorine (Cl) and Bromine (Br) based flame retardants meet JS709B low halogen requirements of <=1000ppm threshold. Antimony trioxide based flame retardants must also meet the <=1000ppm threshold requirement.

(3) MSL, Peak Temp. - The Moisture Sensitivity Level rating according to the JEDEC industry standard classifications, and peak solder temperature.

- (4) There may be additional marking, which relates to the logo, the lot trace code information, or the environmental category on the device.
- (5) Multiple Device Markings will be inside parentheses. Only one Device Marking contained in parentheses and separated by a "~" will appear on a device. If a line is indented then it is a continuation of the previous line and the two combined represent the entire Device Marking for that device.
- (6) Lead finish/Ball material - Orderable Devices may have multiple material finish options. Finish options are separated by a vertical ruled line. Lead finish/Ball material values may wrap to two lines if the finish value exceeds the maximum column width.

**Important Information and Disclaimer:**The information provided on this page represents TI's knowledge and belief as of the date that it is provided. TI bases its knowledge and belief on information provided by third parties, and makes no representation or warranty as to the accuracy of such information. Efforts are underway to better integrate information from third parties. TI has taken and continues to take reasonable steps to provide representative and accurate information but may not have conducted destructive testing or chemical analysis on incoming materials and chemicals. TI and TI suppliers consider certain information to be proprietary, and thus CAS numbers and other limited information may not be available for release.

In no event shall TI's liability arising out of such information exceed the total purchase price of the TI part(s) at issue in this document sold by TI to Customer on an annual basis.

**OTHER QUALIFIED VERSIONS OF LSF0102, LSF0108 :**

- Automotive : [LSF0102-Q1](#), [LSF0108-Q1](#)

NOTE: Qualified Version Definitions:

- Automotive - Q100 devices qualified for high-reliability automotive applications targeting zero defects

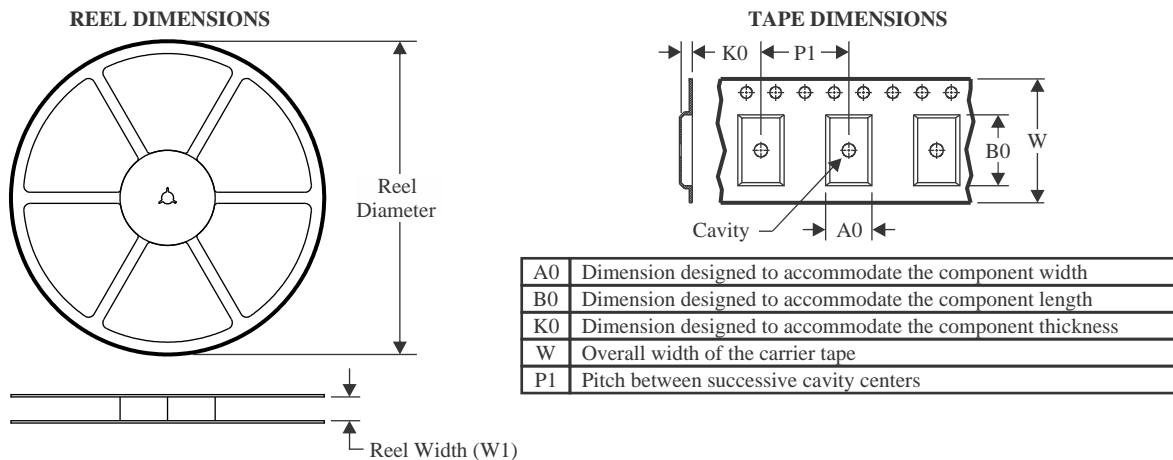
**TAPE AND REEL INFORMATION**

**QUADRANT ASSIGNMENTS FOR PIN 1 ORIENTATION IN TAPE**

\*All dimensions are nominal

Device	Package Type	Package Drawing	Pins	SPQ	Reel Diameter (mm)	Reel Width W1 (mm)	A0 (mm)	B0 (mm)	K0 (mm)	P1 (mm)	W (mm)	Pin1 Quadrant
LSF0101DRYR	SON	DRY	6	5000	180.0	9.5	1.15	1.6	0.75	4.0	8.0	Q1
LSF0101DTQR	X2SON	DTQ	6	3000	180.0	9.5	0.94	1.13	0.5	2.0	8.0	Q2
LSF0102DCTR	SM8	DCT	8	3000	180.0	13.0	3.35	4.5	1.55	4.0	12.0	Q3
LSF0102DCTR	SM8	DCT	8	3000	177.8	12.4	3.45	4.4	1.45	4.0	12.0	Q3
LSF0102DCUR	VSSOP	DCU	8	3000	180.0	9.0	2.25	3.4	1.0	4.0	8.0	Q3
LSF0102DCUR	VSSOP	DCU	8	3000	180.0	8.4	2.25	3.35	1.05	4.0	8.0	Q3
LSF0102DCUR	VSSOP	DCU	8	3000	178.0	9.0	2.25	3.35	1.05	4.0	8.0	Q3
LSF0102DDFR	SOT-23-THIN	DDF	8	3000	180.0	8.4	3.2	3.1	1.25	4.0	8.0	Q3
LSF0102DQER	X2SON	DQE	8	5000	180.0	9.5	1.15	1.6	0.5	4.0	8.0	Q1
LSF0102YZTR	DSBGA	YZT	8	3000	180.0	8.4	1.02	2.02	0.75	4.0	8.0	Q1
LSF0108DGSR	VSSOP	DGS	20	5000	330.0	16.4	5.4	5.4	1.45	8.0	16.0	Q1
LSF0108PWR	TSSOP	PW	20	2000	330.0	16.4	6.95	7.1	1.6	8.0	16.0	Q1
LSF0108RKSR	VQFN	RKS	20	3000	177.8	12.4	2.73	4.85	1.03	4.0	12.0	Q1

**TAPE AND REEL BOX DIMENSIONS**

\*All dimensions are nominal

Device	Package Type	Package Drawing	Pins	SPQ	Length (mm)	Width (mm)	Height (mm)
LSF0101DRYR	SON	DRY	6	5000	184.0	184.0	19.0
LSF0101DTQR	X2SON	DTQ	6	3000	189.0	185.0	36.0
LSF0102DCTR	SM8	DCT	8	3000	182.0	182.0	20.0
LSF0102DCTR	SM8	DCT	8	3000	183.0	183.0	20.0
LSF0102DCUR	VSSOP	DCU	8	3000	182.0	182.0	20.0
LSF0102DCUR	VSSOP	DCU	8	3000	202.0	201.0	28.0
LSF0102DCUR	VSSOP	DCU	8	3000	180.0	180.0	18.0
LSF0102DDFR	SOT-23-THIN	DDF	8	3000	210.0	185.0	35.0
LSF0102DQER	X2SON	DQE	8	5000	184.0	184.0	19.0
LSF0102YZTR	DSBGA	YZT	8	3000	182.0	182.0	20.0
LSF0108DGSR	VSSOP	DGS	20	5000	356.0	356.0	35.0
LSF0108PWR	TSSOP	PW	20	2000	364.0	364.0	27.0
LSF0108RKSR	VQFN	RKS	20	3000	202.0	201.0	28.0

## GENERIC PACKAGE VIEW

**DRY 6**

**USON - 0.6 mm max height**

PLASTIC SMALL OUTLINE - NO LEAD



Images above are just a representation of the package family, actual package may vary.  
Refer to the product data sheet for package details.

4207181/G



# EXAMPLE BOARD LAYOUT

DRY0006A

USON - 0.6 mm max height

PLASTIC SMALL OUTLINE - NO LEAD

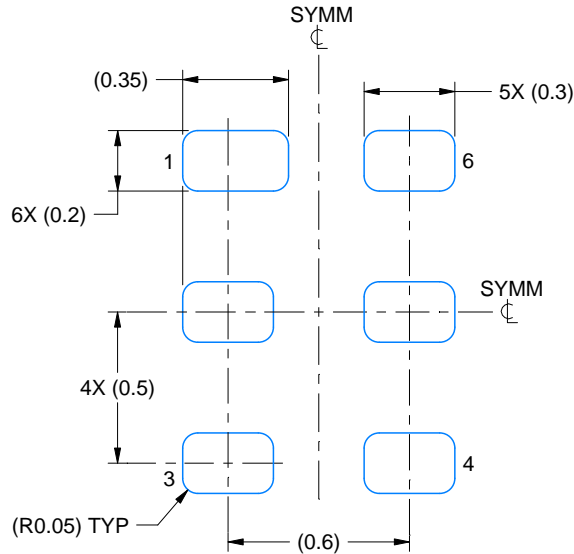

**LAND PATTERN EXAMPLE**  
1:1 RATIO WITH PKG SOLDER PADS  
EXPOSED METAL SHOWN  
SCALE:40X

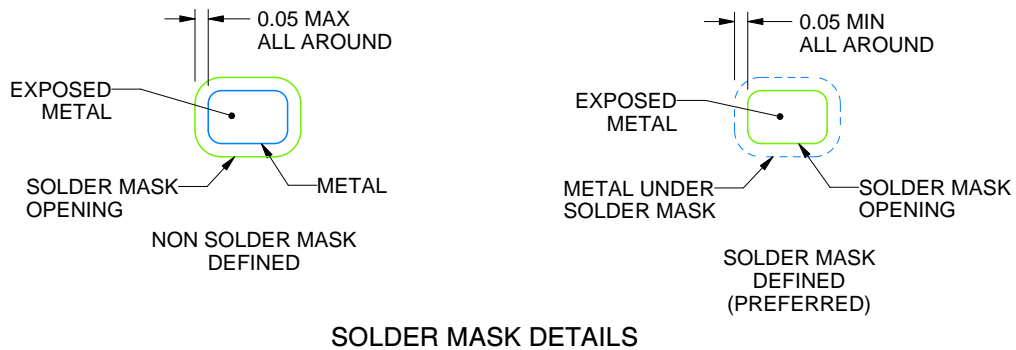

**SOLDER MASK DETAILS**

4222894/A 01/2018

NOTES: (continued)

3. For more information, see QFN/SON PCB application report in literature No. SLUA271 ([www.ti.com/lit/slua271](http://www.ti.com/lit/slua271)).

# EXAMPLE STENCIL DESIGN

DRY0006A

USON - 0.6 mm max height

PLASTIC SMALL OUTLINE - NO LEAD



SOLDER PASTE EXAMPLE  
BASED ON 0.075 - 0.1 mm THICK STENCIL  
SCALE:40X

4222894/A 01/2018

NOTES: (continued)

4. Laser cutting apertures with trapezoidal walls and rounded corners may offer better paste release. IPC-7525 may have alternate design recommendations.



PW0020A



# PACKAGE OUTLINE

## TSSOP - 1.2 mm max height

SMALL OUTLINE PACKAGE



4220206/A 02/2017

### NOTES:

- All linear dimensions are in millimeters. Any dimensions in parenthesis are for reference only. Dimensioning and tolerancing per ASME Y14.5M.
- This drawing is subject to change without notice.
- This dimension does not include mold flash, protrusions, or gate burrs. Mold flash, protrusions, or gate burrs shall not exceed 0.15 mm per side.
- This dimension does not include interlead flash. Interlead flash shall not exceed 0.25 mm per side.
- Reference JEDEC registration MO-153.

# EXAMPLE BOARD LAYOUT

PW0020A

TSSOP - 1.2 mm max height

SMALL OUTLINE PACKAGE



LAND PATTERN EXAMPLE  
EXPOSED METAL SHOWN  
SCALE: 10X



SOLDER MASK DETAILS

4220206/A 02/2017

NOTES: (continued)

- 6. Publication IPC-7351 may have alternate designs.
- 7. Solder mask tolerances between and around signal pads can vary based on board fabrication site.

# EXAMPLE STENCIL DESIGN

PW0020A

TSSOP - 1.2 mm max height

SMALL OUTLINE PACKAGE

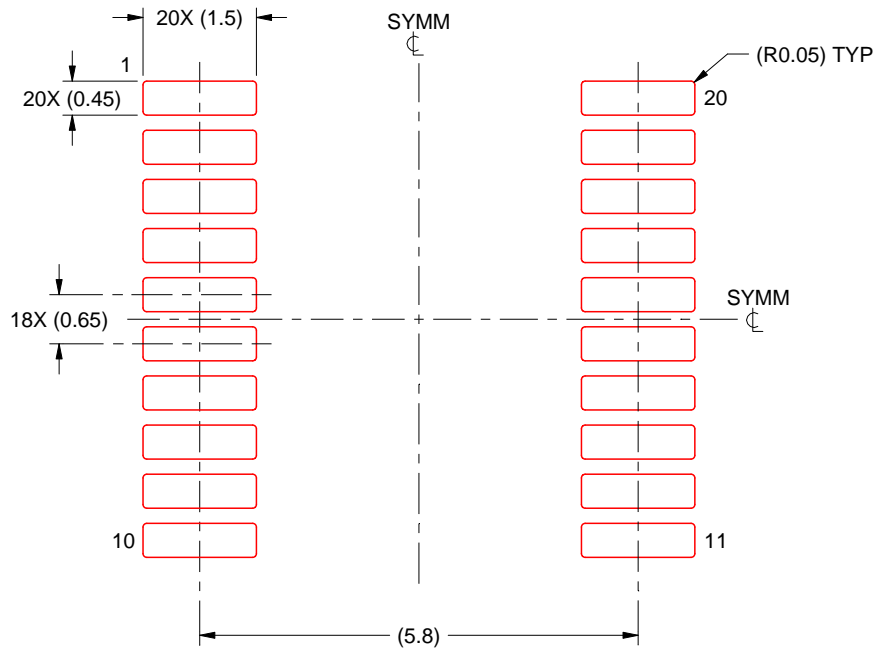

SOLDER PASTE EXAMPLE  
BASED ON 0.125 mm THICK STENCIL  
SCALE: 10X

4220206/A 02/2017

NOTES: (continued)

8. Laser cutting apertures with trapezoidal walls and rounded corners may offer better paste release. IPC-7525 may have alternate design recommendations.
9. Board assembly site may have different recommendations for stencil design.

PW (R-PDSO-G20)

PLASTIC SMALL OUTLINE



- NOTES:
- A. All linear dimensions are in millimeters.
  - B. This drawing is subject to change without notice.
  - C. Publication IPC-7351 is recommended for alternate design.
  - D. Laser cutting apertures with trapezoidal walls and also rounding corners will offer better paste release. Customers should contact their board assembly site for stencil design recommendations. Refer to IPC-7525 for other stencil recommendations.
  - E. Customers should contact their board fabrication site for solder mask tolerances between and around signal pads.

# DDF0008A



# PACKAGE OUTLINE

## SOT-23 - 1.1 mm max height

PLASTIC SMALL OUTLINE



4222047/C 10/2022

### NOTES:

1. All linear dimensions are in millimeters. Any dimensions in parenthesis are for reference only. Dimensioning and tolerancing per ASME Y14.5M.
2. This drawing is subject to change without notice.
3. This dimension does not include mold flash, protrusions, or gate burrs. Mold flash, protrusions, or gate burrs shall not exceed 0.15 mm per side.

# EXAMPLE BOARD LAYOUT

DDF0008A

SOT-23 - 1.1 mm max height

PLASTIC SMALL OUTLINE



LAND PATTERN EXAMPLE  
SCALE:15X



NON SOLDER MASK  
DEFINED



SOLDER MASK  
DEFINED

SOLDER MASK DETAILS

4222047/C 10/2022

NOTES: (continued)

4. Publication IPC-7351 may have alternate designs.
5. Solder mask tolerances between and around signal pads can vary based on board fabrication site.

# EXAMPLE STENCIL DESIGN

DDF0008A

SOT-23 - 1.1 mm max height

PLASTIC SMALL OUTLINE



SOLDER PASTE EXAMPLE  
BASED ON 0.125 mm THICK STENCIL  
SCALE:15X

4222047/C 10/2022

NOTES: (continued)

6. Laser cutting apertures with trapezoidal walls and rounded corners may offer better paste release. IPC-7525 may have alternate design recommendations.
7. Board assembly site may have different recommendations for stencil design.

**MECHANICAL DATA**

YZT (R-XBGA-N8)

DIE-SIZE BALL GRID ARRAY

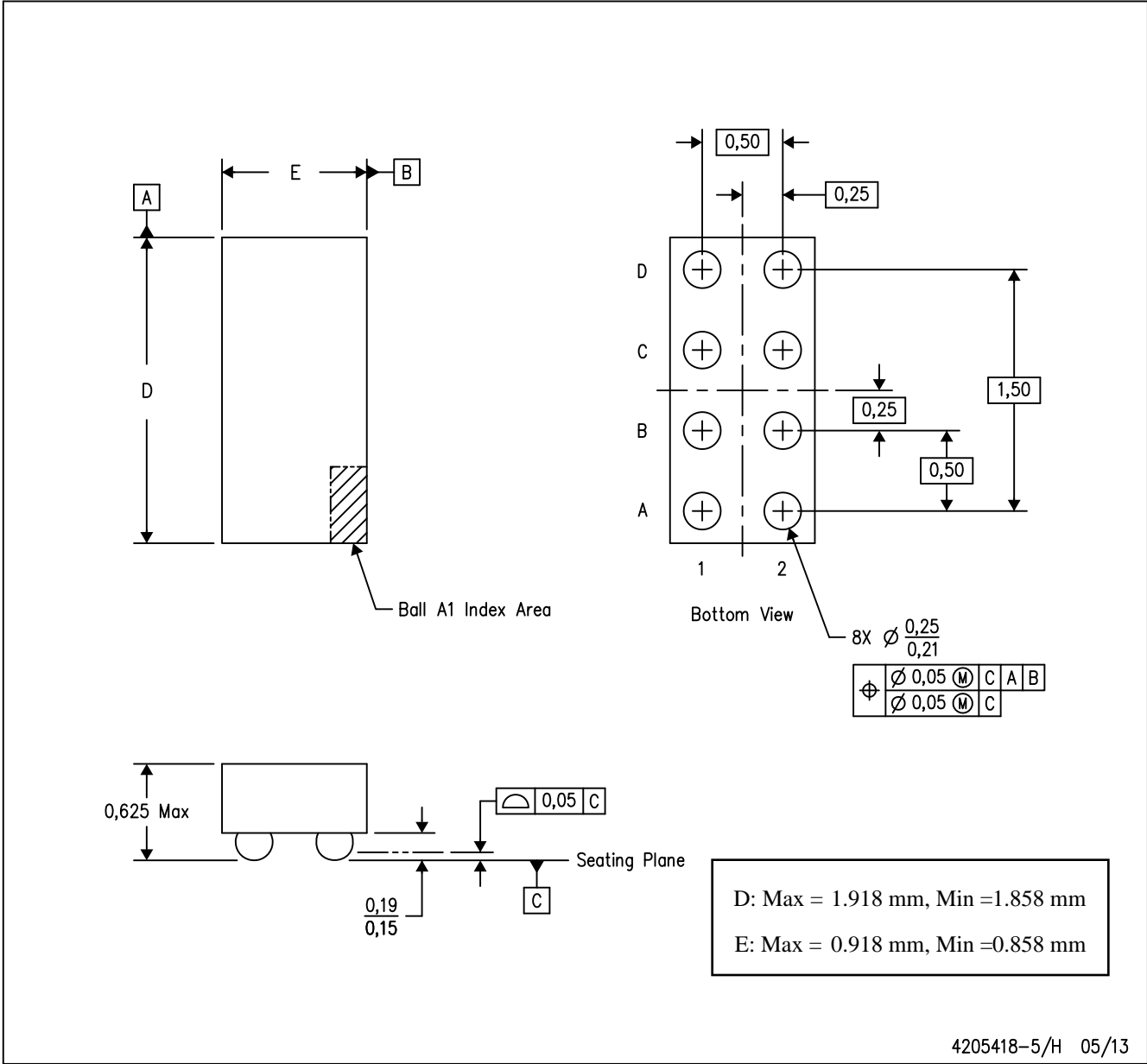

- NOTES:
- A. All linear dimensions are in millimeters. Dimensioning and tolerancing per ASME Y14.5M-1994.
  - B. This drawing is subject to change without notice.
  - C. NanoFree™ package configuration.

NanoFree is a trademark of Texas Instruments.





# EXAMPLE BOARD LAYOUT

DCU0008A

VSSOP - 0.9 mm max height

SMALL OUTLINE PACKAGE

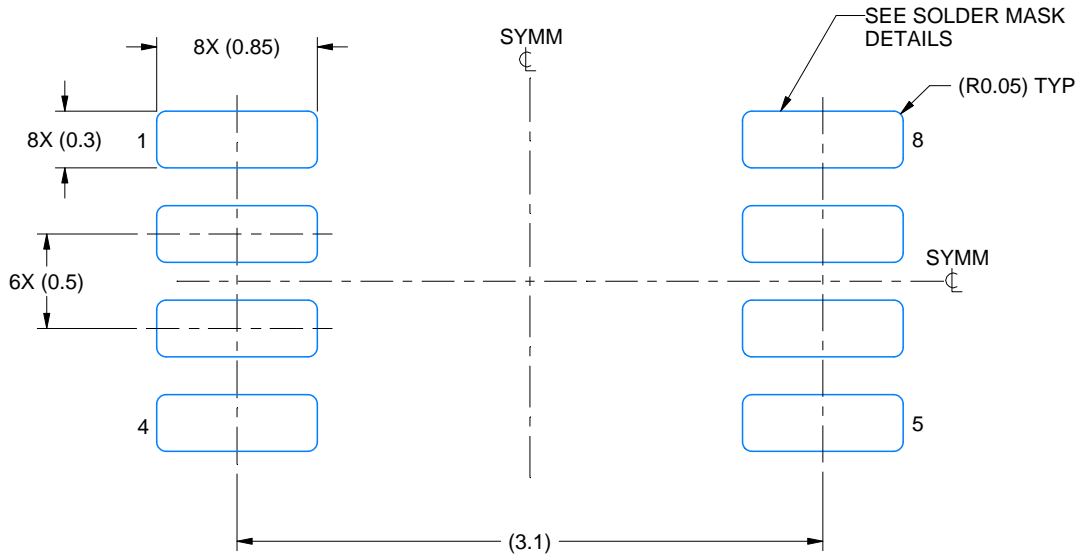

LAND PATTERN EXAMPLE  
EXPOSED METAL SHOWN  
SCALE: 25X



4225266/A 09/2014

NOTES: (continued)

- 5. Publication IPC-7351 may have alternate designs.
- 6. Solder mask tolerances between and around signal pads can vary based on board fabrication site.

# EXAMPLE STENCIL DESIGN

DCU0008A

VSSOP - 0.9 mm max height

SMALL OUTLINE PACKAGE



SOLDER PASTE EXAMPLE  
BASED ON 0.125 mm THICK STENCIL  
SCALE: 25X

4225266/A 09/2014

NOTES: (continued)

7. Laser cutting apertures with trapezoidal walls and rounded corners may offer better paste release. IPC-7525 may have alternate design recommendations.
8. Board assembly site may have different recommendations for stencil design.

## GENERIC PACKAGE VIEW

**RKS 20**

**VQFN - 1 mm max height**

2.5 x 4.5, 0.5 mm pitch

PLASTIC QUAD FLATPACK - NO LEAD

This image is a representation of the package family, actual package may vary.  
Refer to the product data sheet for package details.

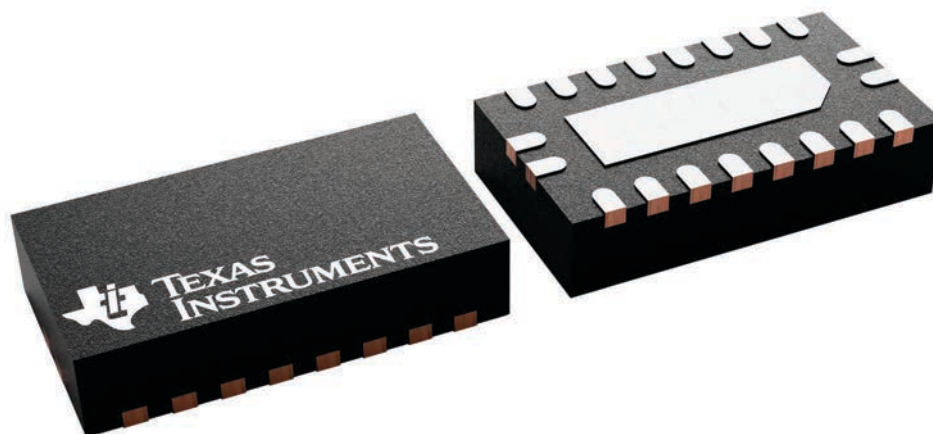

4226872/A

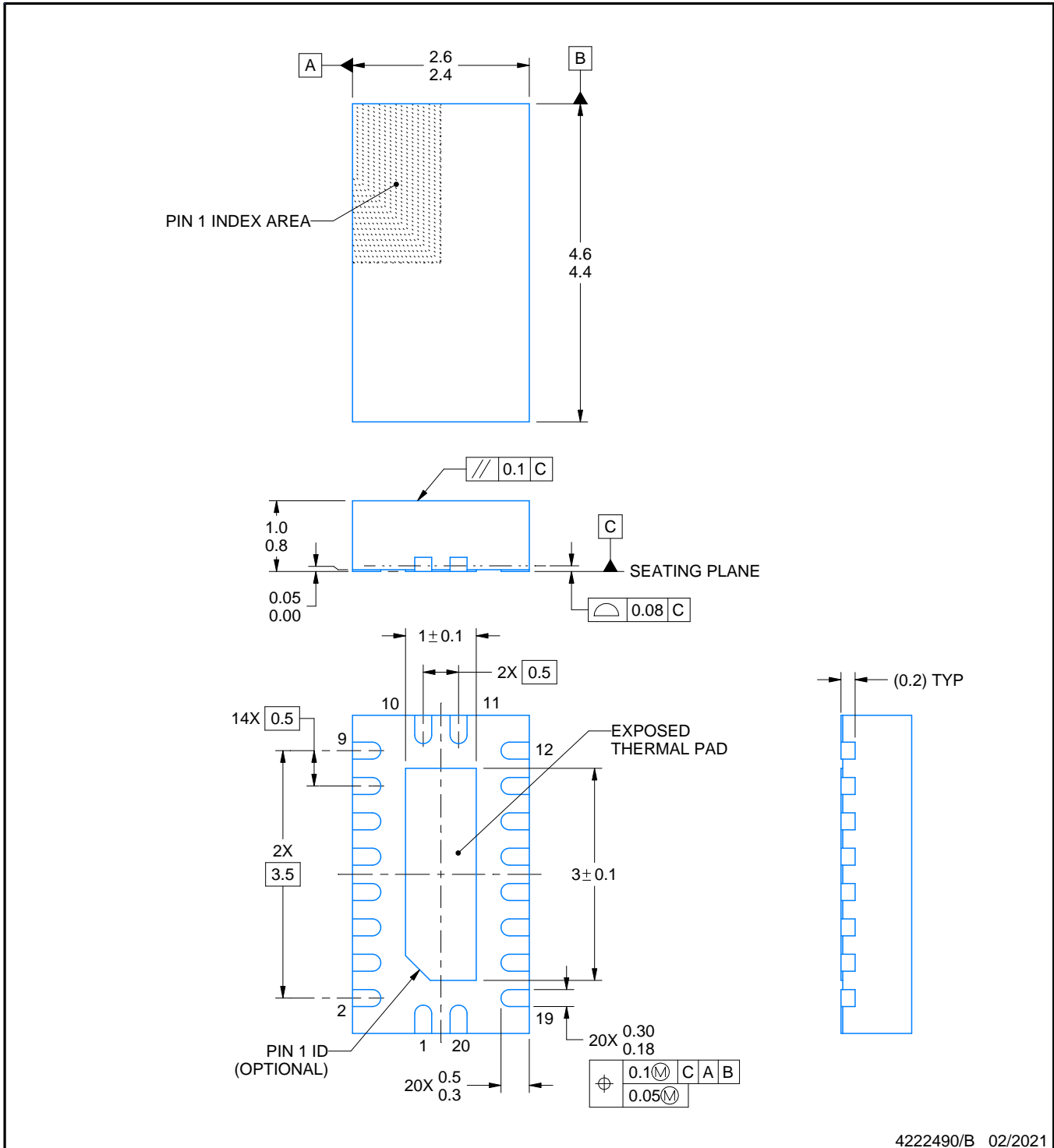

4222490/B 02/2021

NOTES:

1. All linear dimensions are in millimeters. Any dimensions in parenthesis are for reference only. Dimensioning and tolerancing per ASME Y14.5M.
2. This drawing is subject to change without notice.
3. The package thermal pad must be soldered to the printed circuit board for thermal and mechanical performance.



# EXAMPLE STENCIL DESIGN

RKS0020A

VQFN - 1 mm max height

PLASTIC QUAD FLATPACK - NO LEAD

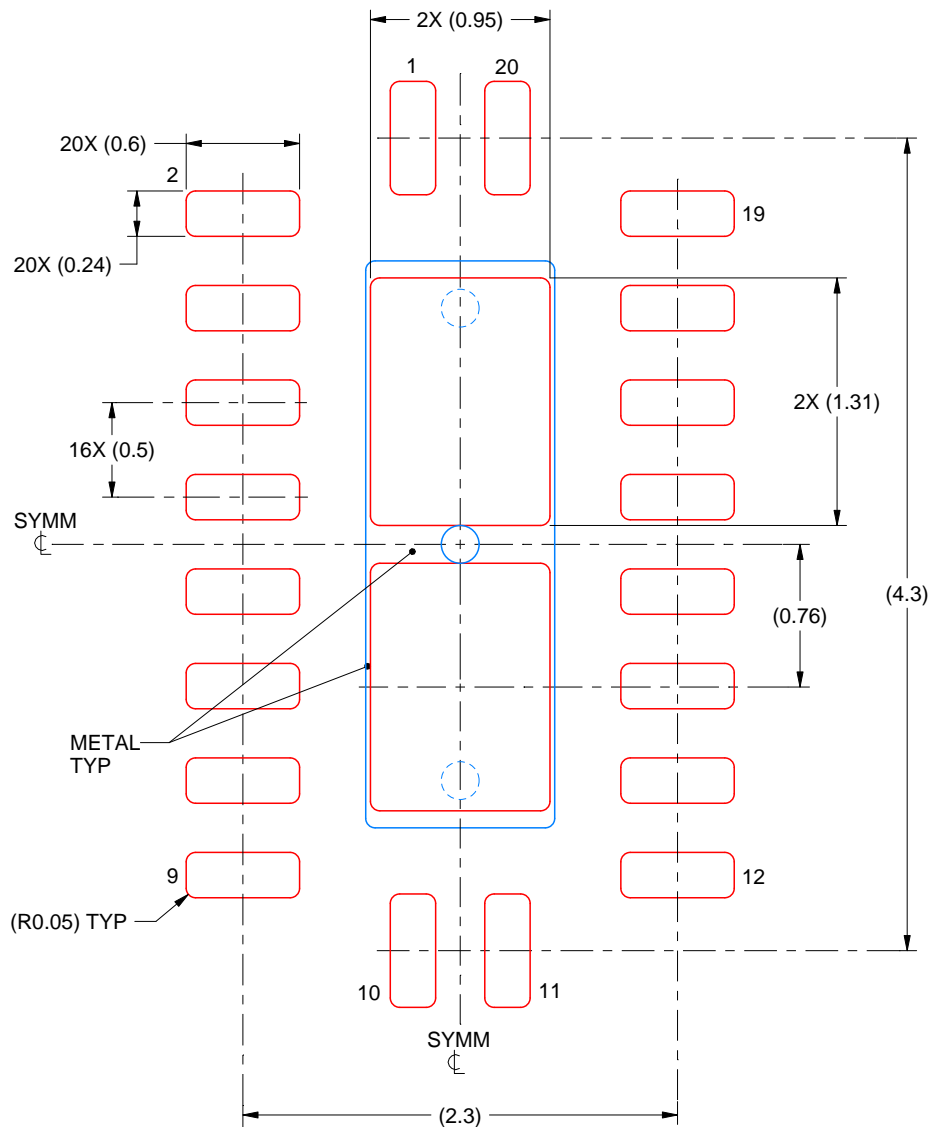

SOLDER PASTE EXAMPLE  
BASED ON 0.125 mm THICK STENCIL

EXPOSED PAD  
83% PRINTED SOLDER COVERAGE BY AREA  
SCALE:25X

4222490/B 02/2021

NOTES: (continued)

6. Laser cutting apertures with trapezoidal walls and rounded corners may offer better paste release. IPC-7525 may have alternate design recommendations.

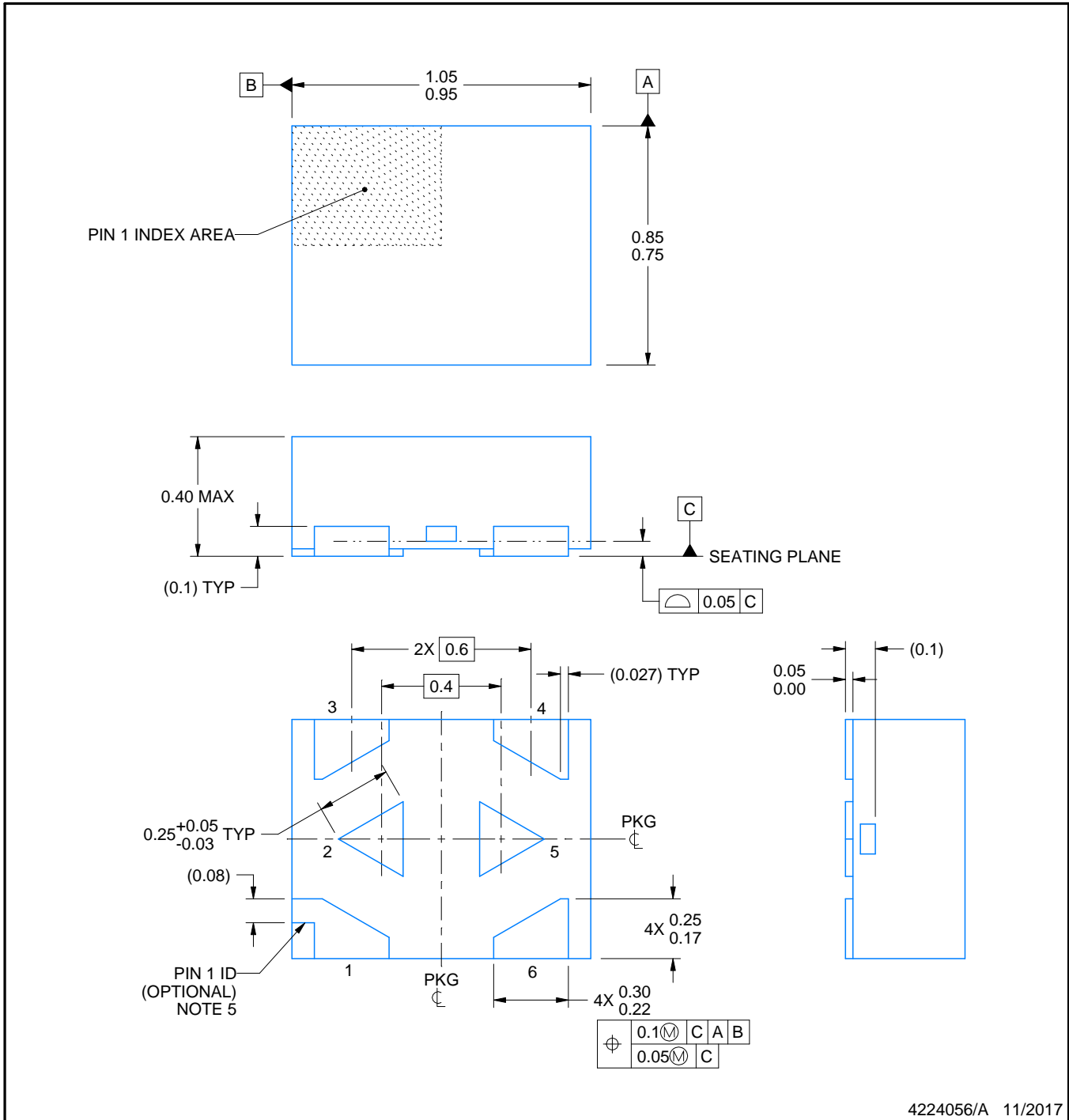

NOTES:

1. All linear dimensions are in millimeters. Any dimensions in parenthesis are for reference only. Dimensioning and tolerancing per ASME Y14.5M.
2. This drawing is subject to change without notice.
3. The package thermal pads must be soldered to the printed circuit board for optimal thermal and mechanical performance.
4. The size and shape of this feature may vary.
5. Features may not exist. Recommend use of pin 1 marking on top of package for orientation purposes.



# EXAMPLE BOARD LAYOUT

DTQ0006A

X2SON - 0.4 mm max height

PLASTIC SMALL OUTLINE - NO LEAD

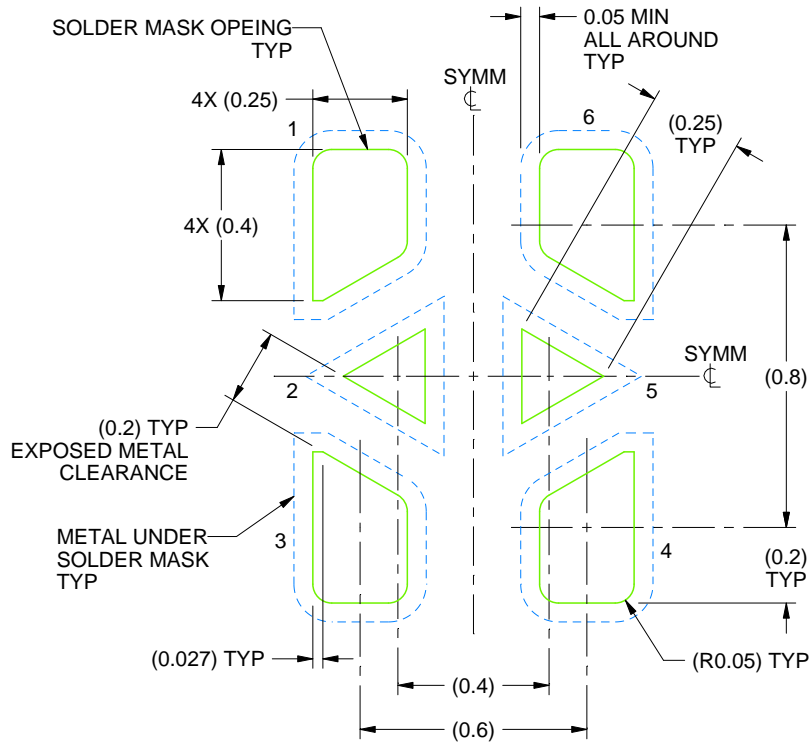

LAND PATTERN EXAMPLE  
SOLDER MASK DEFINED  
SCALE:50X

4224056/A 11/2017

NOTES: (continued)

6. This package is designed to be soldered to a thermal pads on the board. For more information, see Texas Instruments literature number SLUA271 ([www.ti.com/lit/slue271](http://www.ti.com/lit/slue271)).
7. Vias are optional depending on application, refer to device data sheet. If some or all are implemented, recommended via locations are shown.

# EXAMPLE STENCIL DESIGN

DTQ0006A

X2SON - 0.4 mm max height

PLASTIC SMALL OUTLINE - NO LEAD

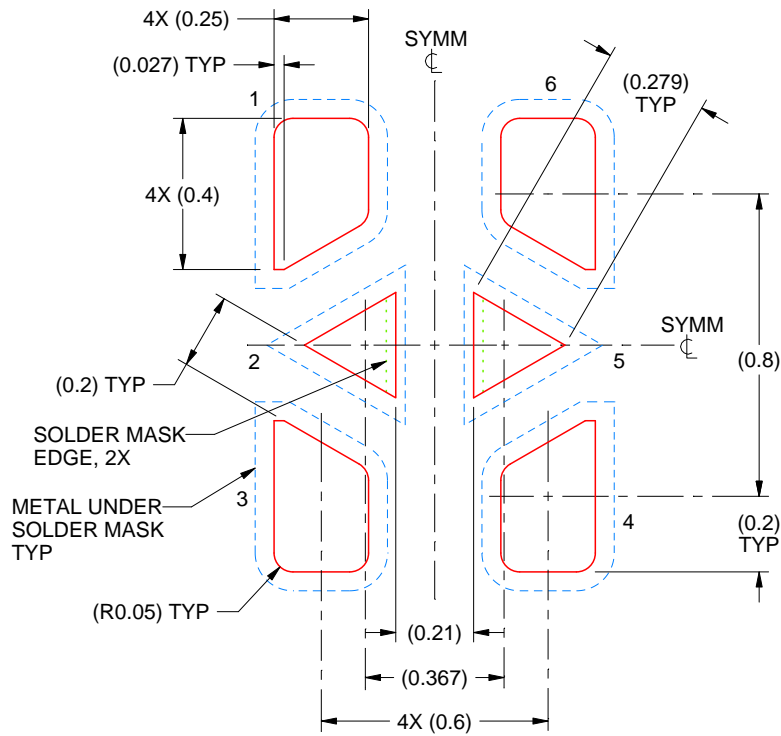

SOLDER PASTE EXAMPLE  
BASED ON 0.07 mm THICK STENCIL

PRINTED SOLDER COVERAGE BY AREA UNDER PACKAGE  
SCALE:50X

4224056/A 11/2017

NOTES: (continued)

8. Laser cutting apertures with trapezoidal walls and rounded corners may offer better paste release. IPC-7525 may have alternate design recommendations.



4220784/C 06/2021

NOTES:

1. All linear dimensions are in millimeters. Dimensions in parenthesis are for reference only. Dimensioning and tolerancing per ASME Y14.5M.
2. This drawing is subject to change without notice.
3. This dimension does not include mold flash, protrusions, or gate burrs. Mold flash, protrusions, or gate burrs shall not exceed 0.15 mm per side.
4. This dimension does not include interlead flash. Interlead flash shall not exceed 0.25 mm per side.

# EXAMPLE BOARD LAYOUT

DCT0008A

SSOP - 1.3 mm max height

SMALL OUTLINE PACKAGE



LAND PATTERN EXAMPLE  
EXPOSED METAL SHOWN  
SCALE:15X



SOLDER MASK DETAILS

4220784/C 06/2021

NOTES: (continued)

- 5. Publication IPC-7351 may have alternate designs.
- 6. Solder mask tolerances between and around signal pads can vary based on board fabrication site.

# EXAMPLE STENCIL DESIGN

DCT0008A

SSOP - 1.3 mm max height

SMALL OUTLINE PACKAGE



SOLDER PASTE EXAMPLE  
BASED ON 0.125 mm THICK STENCIL  
SCALE:15X

4220784/C 06/2021

NOTES: (continued)

7. Laser cutting apertures with trapezoidal walls and rounded corners may offer better paste release. IPC-7525 may have alternate design recommendations.
8. Board assembly site may have different recommendations for stencil design.

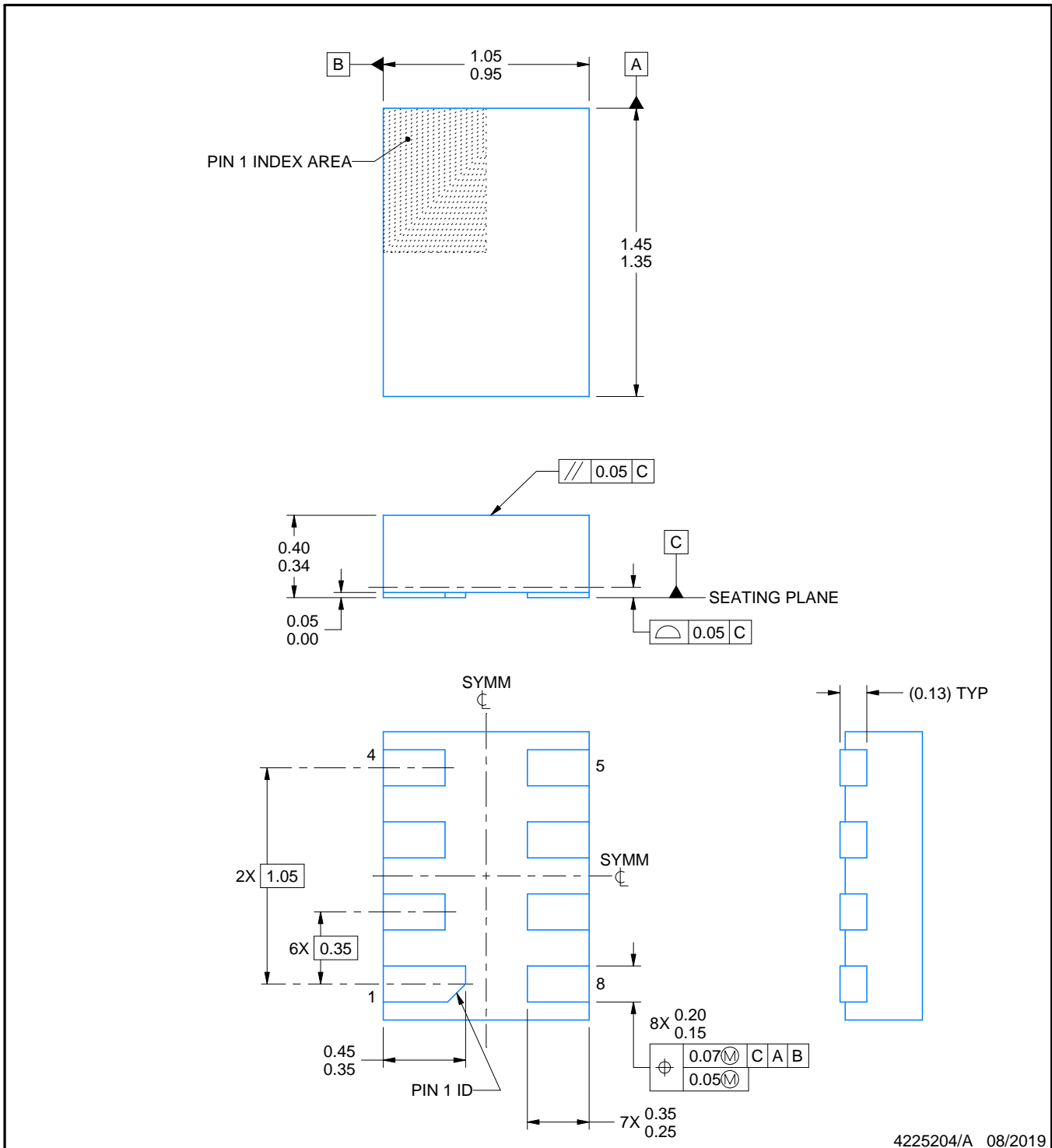
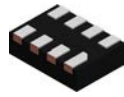

4225204/A 08/2019

NOTES:

1. All linear dimensions are in millimeters. Any dimensions in parenthesis are for reference only. Dimensioning and tolerancing per ASME Y14.5M.
2. This drawing is subject to change without notice.
3. This package complies to JEDEC MO-287 variation X2EAF.

# EXAMPLE BOARD LAYOUT

DQE0008A

X2SON - 0.4 mm max height

PLASTIC SMALL OUTLINE - NO LEAD

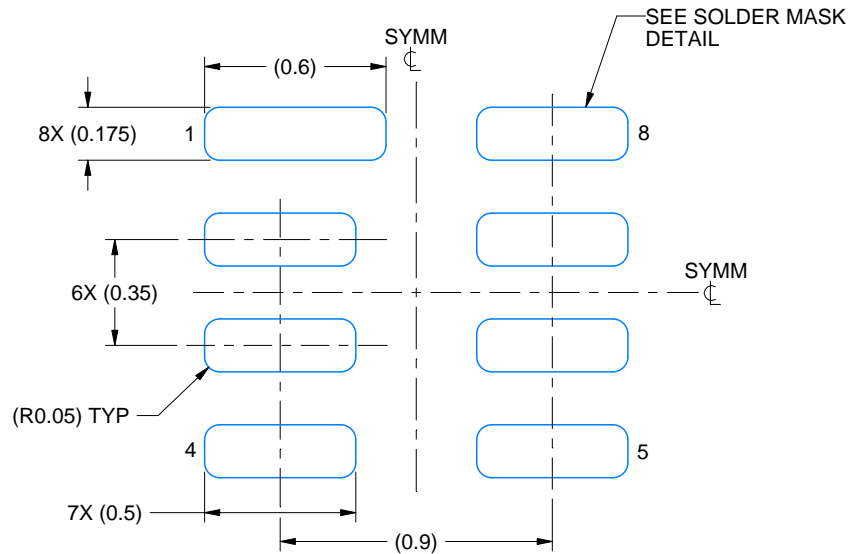

LAND PATTERN EXAMPLE  
EXPOSED METAL SHOWN  
SCALE: 40X

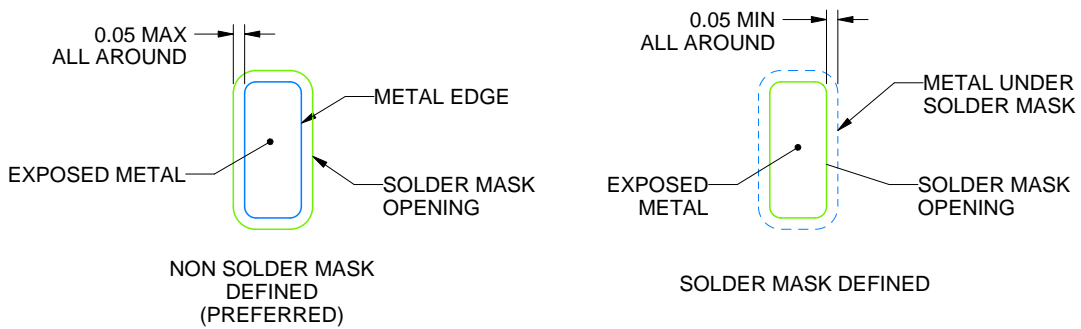

SOLDER MASK DETAILS

4225204/A 08/2019

NOTES: (continued)

- This package is designed to be soldered to a thermal pad on the board. For more information, see Texas Instruments literature number SLUA271 ([www.ti.com/lit/slua271](http://www.ti.com/lit/slua271)).

# EXAMPLE STENCIL DESIGN

DQE0008A

X2SON - 0.4 mm max height

PLASTIC SMALL OUTLINE - NO LEAD

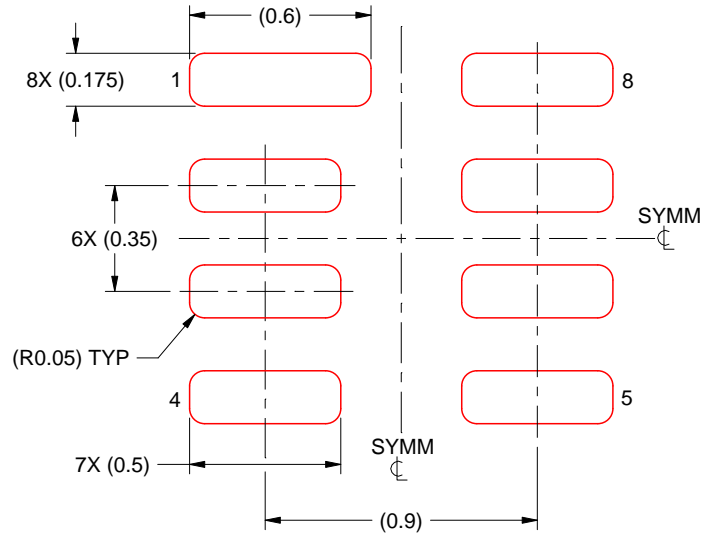

SOLDER PASTE EXAMPLE  
BASED ON 0.075 MM THICK STENCIL  
SCALE: 40X

4225204/A 08/2019

NOTES: (continued)

5. Laser cutting apertures with trapezoidal walls and rounded corners may offer better paste release. IPC-7525 may have alternate design recommendations.



## IMPORTANT NOTICE AND DISCLAIMER

TI PROVIDES TECHNICAL AND RELIABILITY DATA (INCLUDING DATA SHEETS), DESIGN RESOURCES (INCLUDING REFERENCE DESIGNS), APPLICATION OR OTHER DESIGN ADVICE, WEB TOOLS, SAFETY INFORMATION, AND OTHER RESOURCES "AS IS" AND WITH ALL FAULTS, AND DISCLAIMS ALL WARRANTIES, EXPRESS AND IMPLIED, INCLUDING WITHOUT LIMITATION ANY IMPLIED WARRANTIES OF MERCHANTABILITY, FITNESS FOR A PARTICULAR PURPOSE OR NON-INFRINGEMENT OF THIRD PARTY INTELLECTUAL PROPERTY RIGHTS.

These resources are intended for skilled developers designing with TI products. You are solely responsible for (1) selecting the appropriate TI products for your application, (2) designing, validating and testing your application, and (3) ensuring your application meets applicable standards, and any other safety, security, regulatory or other requirements.

These resources are subject to change without notice. TI grants you permission to use these resources only for development of an application that uses the TI products described in the resource. Other reproduction and display of these resources is prohibited. No license is granted to any other TI intellectual property right or to any third party intellectual property right. TI disclaims responsibility for, and you will fully indemnify TI and its representatives against, any claims, damages, costs, losses, and liabilities arising out of your use of these resources.

TI's products are provided subject to [TI's Terms of Sale](#) or other applicable terms available either on [ti.com](https://www.ti.com) or provided in conjunction with such TI products. TI's provision of these resources does not expand or otherwise alter TI's applicable warranties or warranty disclaimers for TI products.

TI objects to and rejects any additional or different terms you may have proposed.

Mailing Address: Texas Instruments, Post Office Box 655303, Dallas, Texas 75265  
Copyright © 2023, Texas Instruments Incorporated