

## 100 mA Low-Dropout Voltage Regulator

### Features

- High Accuracy 5V, Guaranteed 100 mA Output
- Extremely Low Quiescent Current
- Low-Dropout Voltage
- Extremely Tight Load and Line Regulation
- Very Low Temperature Coefficient
- Use as Regulator or Reference
- Needs Only 1  $\mu\text{F}$  for Stability
- Current and Thermal Limiting
- Error Flag Warns of Output Dropout
- Logic-Controlled Electronic Shutdown
- Output Programmable from 1.24V to 29V

### Applications

- Automotive Electronics
- Voltage Reference
- Avionics

### General Description

The LP2951 is micropower voltage regulators with very low dropout voltage (typically 40 mV at light loads and 380 mV at 100 mA), and very low quiescent current (75  $\mu\text{A}$  typical). The quiescent current of the LP2951 increases only slightly in dropout, thus prolonging battery life. This feature, among others, makes the LP2951 ideally suited for use in battery-powered systems.

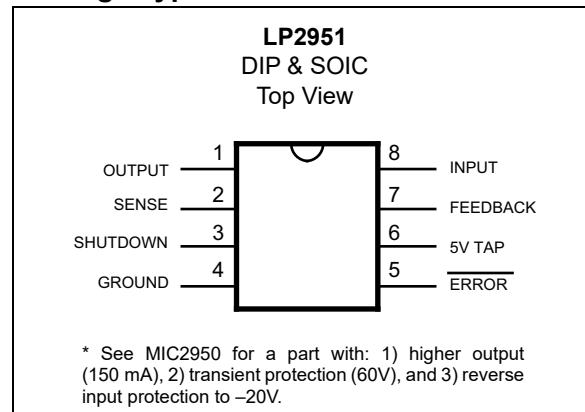
Available system functions, such as programmable output voltage and logic-controlled shutdown, are available as well.

Additional features available with the LP2951 also include an error flag output that warns of a low output voltage, which is often due to failing batteries on the input. This may also be used as a power-on reset. A logic-compatible shutdown input is also available which enables the regulator to be switched on and off. This part may also be pin-strapped for a 5V output, or programmed from 1.24V to 29V with the use of two external resistors.

The LP2951 is available as either a -02 or -03 version. The -02 and -03 versions are guaranteed for junction temperatures from  $-40^{\circ}\text{C}$  to  $+125^{\circ}\text{C}$ ; the -02 version has a tighter output and reference voltage specification range over temperature.

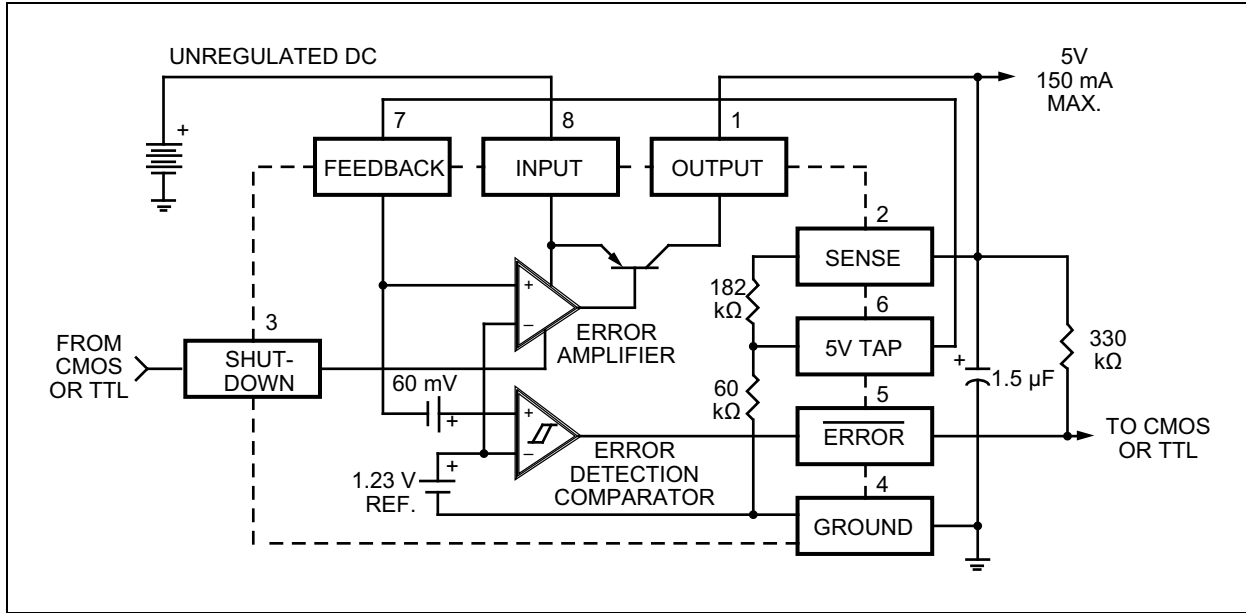
The LP2951 have a tight initial tolerance (0.5% typical), a very low output voltage temperature coefficient which allows use as a low-power voltage reference, and extremely good load and line regulation (0.05% typical). This greatly reduces the error in the overall circuit, and is the result of careful design techniques and process control.

### Package Types

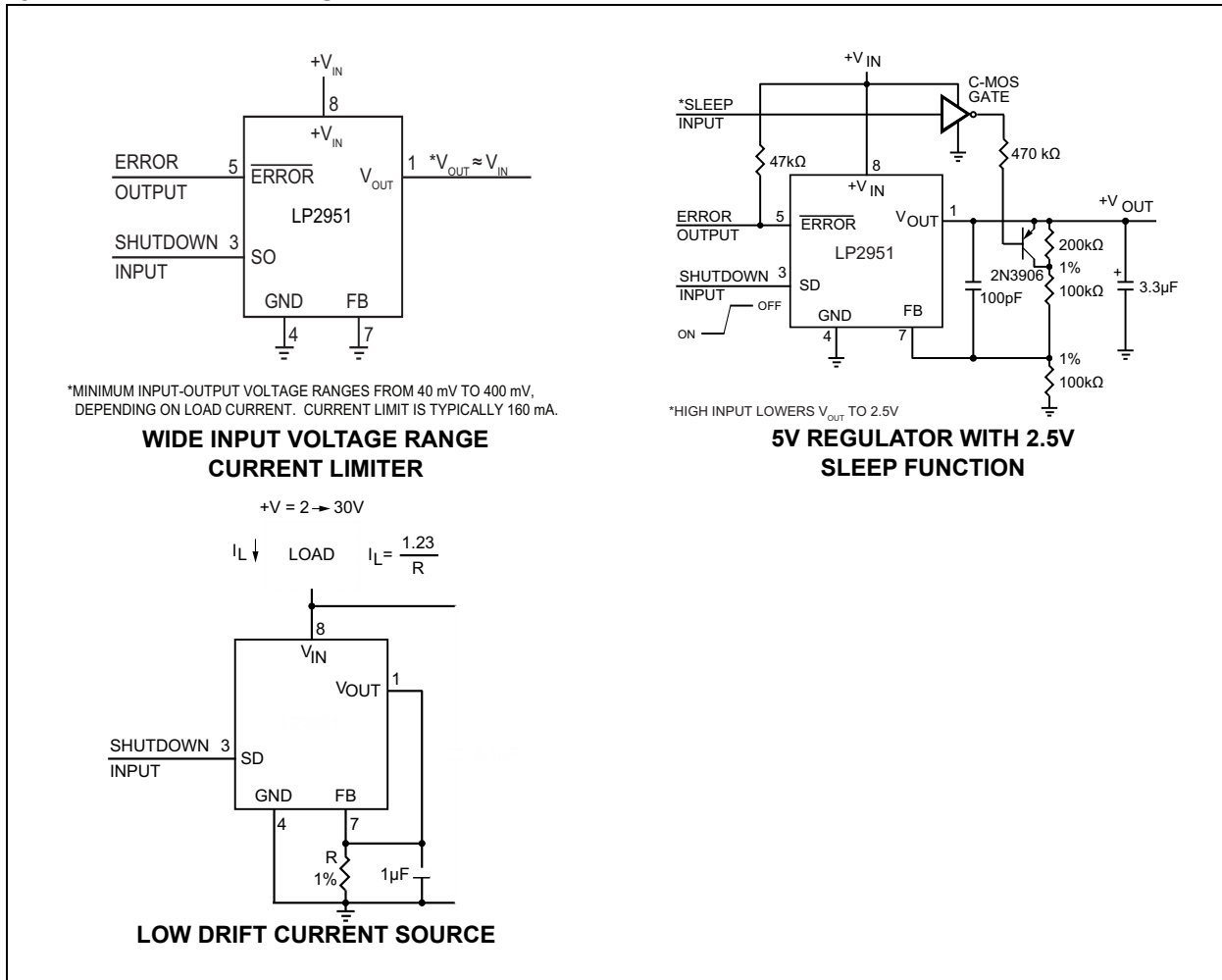


# LP2951

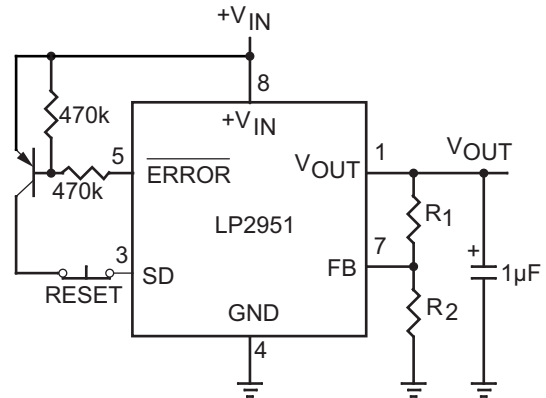
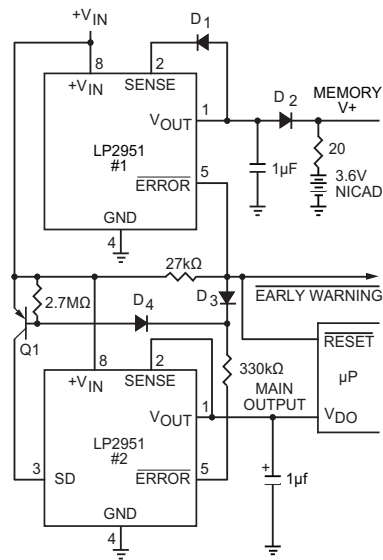
## Functional Block Diagram



## Typical Application Diagrams



## Typical Application Diagrams

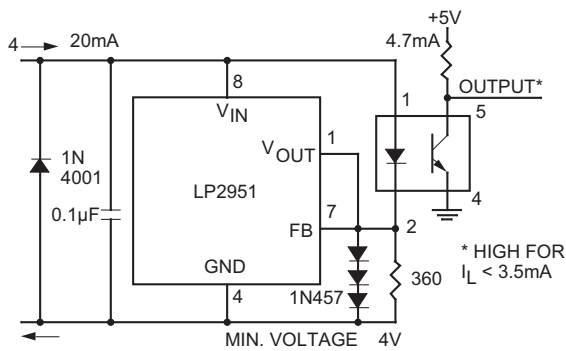


**LATCH-OFF WHEN ERROR FLAG OCCURS**

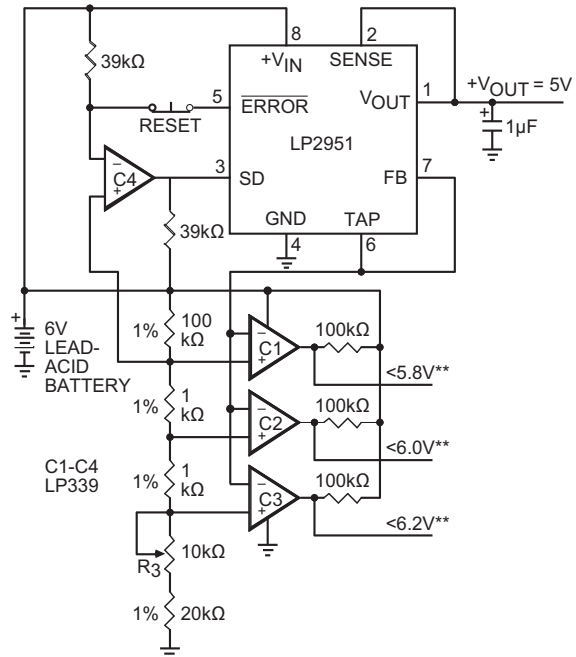
- EARLY WARNING FLAG ON LOW INPUT VOLTAGE
- MAIN OUTPUT LATCHES OFF AT LOWER INPUT VOLTAGES
- BATTERY BACKUP ON AUXILIARY OUTPUT

OPERATION: REG. #1'S  $V_{OUT}$  IS PROGRAMMED ONE DIODE DROP ABOVE 5V. ITS ERROR FLAG BECOMES ACTIVE WHEN  $V_{IN} \leq 5.7V$ . WHEN  $V_{IN}$  DROPS BELOW 5.3V, THE ERROR FLAG OF REG. #2 BECOMES ACTIVE AND VIA Q1 LATCHES THE MAIN OUTPUT OFF. WHEN  $V_{IN}$  AGAIN EXCEEDS 5.7V REG. #1 IS BACK IN REGULATION AND THE EARLY WARNING SIGNAL RISES, UNLATCHING REG. #2 VIA D3.

### REGULATOR WITH EARLY WARNING AND AUXILIARY OUTPUT



### OPEN CIRCUIT DETECTOR FOR 4 mA TO 20 mA CURRENT LOOP



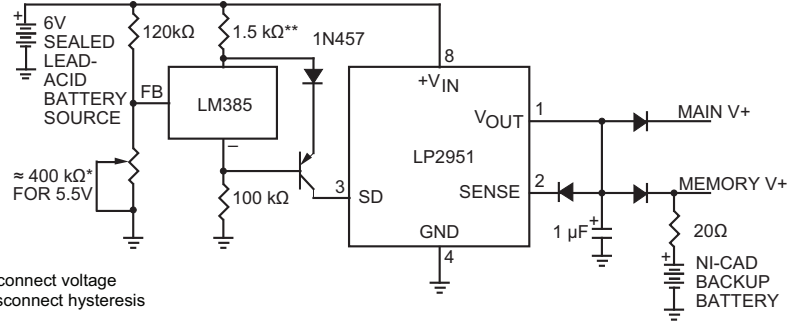
C1 TO C4 ARE COMPARATORS (LP339 OR EQUIVALENT)

\*OPTIONAL LATCH OFF WHEN DROP OUT OCCURS. ADJUST R3 FOR C2 SWITCHING WHEN  $V_{IN}$  IS 6.0V

\*\*OUTPUTS GO LOW WHEN  $V_{IN}$  DROPS BELOW DESIGNATED THRESHOLDS.

### REGULATOR WITH STATE-OF-CHARGE INDICATOR

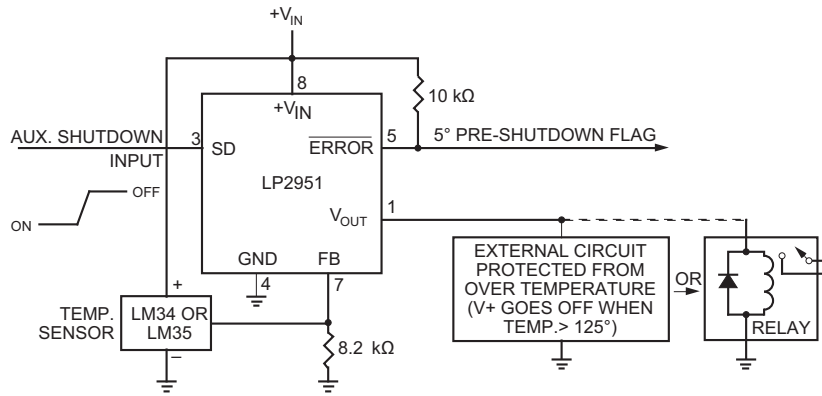
# LP2951



\* Sets disconnect voltage  
 \*\* Sets disconnect hysteresis

For values shown, Regulator shuts down when  $V_{IN} < 5.5V$  and turns on again at 6.0V. Current drain in disconnected mode is 150  $\mu A$ .

## LOW BATTERY DISCONNECT



LM34 for 125°F Shutdown  
 LM35 for 125°C Shutdown

## SYSTEM OVERTEMPERATURE PROTECTION CIRCUIT

## 1.0 ELECTRICAL CHARACTERISTICS

### Absolute Maximum Ratings † ††

Power Dissipation .....	Internally Limited
Lead Temperature (soldering, 5 sec.) .....	260°C
Storage Temperature .....	-65°C to +150°C
Operating Junction Temperature Range( <a href="#">Note 1</a> )	
LP2951 .....	-40°C to +125°C
Input Supply Voltage .....	-0.3 to +30V
Feedback Input Voltage( <a href="#">Note 2, 3</a> ) .....	-1.5 to +30V
Shutdown Input Voltage( <a href="#">Note 2</a> ) .....	-0.3 to +30V
Error Comparator Output Voltage( <a href="#">Note 2</a> ) .....	-0.3 to +30V

† **Notice:** Boldface limits apply at temperature extremes.

†† **Notice:** If Military/Aerospace specified devices are required, contact your local representative/distributor for availability and specifications.

**Note 1:** The thermal resistance of the 8-pin DIP package is 105°C/W junction-to-ambient when soldered directly to a PC board. Junction-to-ambient thermal resistance for the SOIC (M) package is 160°C/W.

**2:** May exceed input supply voltage.

**3:** When used in dual-supply systems where the output terminal sees loads returned to a negative supply, the output voltage should be diode-clamped to ground.

# LP2951

## ELECTRICAL CHARACTERISTICS

Electrical Characteristics: Unless otherwise indicated, $T_A = +25^\circ\text{C}$						
Parameters	Symbol	Min.	Typ.	Max.	Units	Conditions
Output Voltage $T_J = 25^\circ\text{C}$	$V_{\text{OUT}}$	4.975	5.000	5.025	V	LP2951-02 ( $\pm 0.5\%$ )
		4.950	5.000	5.050	V	LP2951-03 ( $\pm 1\%$ )
Output Voltage $-25^\circ\text{C} \leq T_J \leq +85^\circ\text{C}$	$V_{\text{OUT}}$	4.950	—	5.050	V	LP2951-02 ( $\pm 0.5\%$ )
		4.925	—	5.075	V	LP2951-03 ( $\pm 1\%$ )
Output Voltage Over Full Temperature Range $-40^\circ\text{C}$ to $+125^\circ\text{C}$	$V_{\text{OUT}}$	<b>4.940</b>	—	<b>5.060</b>	V	LP2951-02 ( $\pm 0.5\%$ )
		<b>4.900</b>	—	<b>5.100</b>	V	LP2951-03 ( $\pm 1\%$ )
Output Voltage Over Load Variation	—	<b>4.930</b>	—	<b>5.070</b>	V	LP2951-02 ( $\pm 0.5\%$ ), $100\ \mu\text{A} \leq I_L \leq 100\ \text{mA}$ , $T_J \leq T_{J(\text{max})}$
		<b>4.880</b>	—	<b>5.120</b>	V	LP2951-03 ( $\pm 1\%$ ), $100\ \mu\text{A} \leq I_L \leq 100\ \text{mA}$ , $T_J \leq T_{J(\text{max})}$
Output Voltage Temperature Coefficient	—	—	<b>20</b>	<b>100</b>	ppm/ $^\circ\text{C}$	LP2951-02 ( $\pm 0.5\%$ ), <a href="#">Note 1</a>
		—	<b>50</b>	<b>150</b>	ppm/ $^\circ\text{C}$	LP2951-03 ( $\pm 1\%$ ), <a href="#">Note 1</a>
Line Regulation	—	—	0.03	0.10	%	LP2951-02 ( $\pm 0.5\%$ ), <a href="#">Note 2</a> , <a href="#">3</a>
		—	—	<b>0.20</b>	%	
		—	0.04	0.20	%	LP2951-03 ( $\pm 1\%$ ), <a href="#">Note 2</a> , <a href="#">3</a>
		—	—	<b>0.40</b>	%	

- Note 1:** Output or reference voltage temperature coefficient is defined as the worst case voltage change divided by the total temperature range.
- 2:** Regulation is measured at constant junction temperature, using pulse testing with a low duty cycle. Changes in output voltage due to heating effects are covered in the specification for thermal regulation.
- 3:** Line regulation for the LP2951 is tested at  $150^\circ\text{C}$  for  $I_L = 1\ \text{mA}$ . For  $I_L = 100\ \mu\text{A}$  and  $T_J = 125^\circ\text{C}$ , line regulation is guaranteed by design to 0.2%. See Typical Performance Characteristics for line regulation versus temperature and load current.
- 4:** Dropout voltage is defined as the input to output differential at which the output voltage drops 100 mV below its nominal value measured at 1V differential. At very low values of programmed output voltage, the minimum input supply voltage of 2V (2.3V over temperature) must be taken into account.
- 5:** Thermal regulation is defined as the change in output voltage at a time T after a change in power dissipation is applied, excluding load or line regulation effects. Specifications are for a 50 mA load pulse at  $V_{\text{IN}} = 30\text{V}$  (1.25W pulse) for  $t = 10\ \text{ms}$ .
- 6:** Comparator thresholds are expressed in terms of a voltage differential at the Feedback terminal below the nominal reference voltage measured at 6V input. To express these thresholds in terms of output voltage change, multiply by the error amplifier gain  $= V_{\text{OUT}}/V_{\text{REF}} = (R1 + R2)/R2$ . For example, at a programmed output voltage of 5V, the Error output is guaranteed to go low when the output drops by  $95\ \text{mV} \times 5\text{V}/1.235\text{V} = 384\ \text{mV}$ . Thresholds remain constant as a percent of  $V_{\text{OUT}}$  as  $V_{\text{OUT}}$  is varied, with the dropout warning occurring at typically 5% below nominal, 7.5% guaranteed.
- 7:**  $V_{\text{REF}} \leq V_{\text{OUT}} \leq (V_{\text{IN}} - 1\ \text{V})$ ,  $2.3\text{V} \leq V_{\text{IN}} \leq 30\text{V}$ ,  $100\ \mu\text{A} < I_L \leq 100\ \text{mA}$ ,  $T_J \leq T_{J\text{MAX}}$ .
- 8:** Output or reference voltage temperature coefficient is defined as the worst case voltage change divided by the total temperature range.
- 9:**  $V_{\text{SHUTDOWN}} \geq 2\text{V}$ ,  $V_{\text{IN}} \leq 30\text{V}$ ,  $V_{\text{OUT}} = 0$ , with Feedback pin tied to 5V Tap.

## ELECTRICAL CHARACTERISTICS (CONTINUED)

Electrical Characteristics: Unless otherwise indicated, $T_A = +25^\circ\text{C}$						
Parameters	Symbol	Min.	Typ.	Max.	Units	Conditions
Load Regulation	—	—	0.04	0.10	%	LP2951-02 ( $\pm 0.5\%$ ), <a href="#">Note 2</a> , $100\ \mu\text{A} \leq I_L \leq 100\ \text{mA}$
		—	—	<b>0.20</b>	%	
		—	0.10	0.20	%	LP2951-03 ( $\pm 1\%$ ), <a href="#">Note 2</a> , $100\ \mu\text{A} \leq I_L \leq 100\ \text{mA}$
		—	—	<b>0.30</b>	%	
Dropout Voltage	$V_{\text{DO}}$	—	50	80	mV	<a href="#">Note 4</a> , $I_L = 100\ \mu\text{A}$
		—	—	150	mV	
		—	380	450	mV	<a href="#">Note 4</a> , $I_L = 100\ \text{mA}$
		—	—	600	mV	
Ground Current	$I_{\text{GND}}$	—	100	150	$\mu\text{A}$	$I_L = 100\ \mu\text{A}$
		—	—	200	$\mu\text{A}$	
		—	8	12	mA	$I_L = 100\ \text{mA}$
		—	—	14	mA	
Dropout Current	$I_{\text{DO}}$	—	180	250 310	$\mu\text{A}$ $\mu\text{A}$	$V_{\text{IN}} = 4.5\text{V}$ , $I_L = 100\ \mu\text{A}$
Current Limit	$I_{\text{LIM}}$	—	160	220 220	mA mA	$V_{\text{OUT}} = 0\text{V}$
Thermal Regulation	—	—	0.05	0.20	%/W	<a href="#">Note 5</a>

- Note 1:** Output or reference voltage temperature coefficient is defined as the worst case voltage change divided by the total temperature range.
- 2:** Regulation is measured at constant junction temperature, using pulse testing with a low duty cycle. Changes in output voltage due to heating effects are covered in the specification for thermal regulation.
- 3:** Line regulation for the LP2951 is tested at  $150^\circ\text{C}$  for  $I_L = 1\ \text{mA}$ . For  $I_L = 100\ \mu\text{A}$  and  $T_J = 125^\circ\text{C}$ , line regulation is guaranteed by design to 0.2%. See Typical Performance Characteristics for line regulation versus temperature and load current.
- 4:** Dropout voltage is defined as the input to output differential at which the output voltage drops 100 mV below its nominal value measured at 1V differential. At very low values of programmed output voltage, the minimum input supply voltage of 2V (2.3V over temperature) must be taken into account.
- 5:** Thermal regulation is defined as the change in output voltage at a time T after a change in power dissipation is applied, excluding load or line regulation effects. Specifications are for a 50 mA load pulse at  $V_{\text{IN}} = 30\text{V}$  (1.25W pulse) for  $t = 10\ \text{ms}$ .
- 6:** Comparator thresholds are expressed in terms of a voltage differential at the Feedback terminal below the nominal reference voltage measured at 6V input. To express these thresholds in terms of output voltage change, multiply by the error amplifier gain  $= V_{\text{OUT}}/V_{\text{REF}} = (R1 + R2)/R2$ . For example, at a programmed output voltage of 5V, the Error output is guaranteed to go low when the output drops by  $95\ \text{mV} \times 5\text{V}/1.235\text{V} = 384\ \text{mV}$ . Thresholds remain constant as a percent of  $V_{\text{OUT}}$  as  $V_{\text{OUT}}$  is varied, with the dropout warning occurring at typically 5% below nominal, 7.5% guaranteed.
- 7:**  $V_{\text{REF}} \leq V_{\text{OUT}} \leq (V_{\text{IN}} - 1\ \text{V})$ ,  $2.3\text{V} \leq V_{\text{IN}} \leq 30\text{V}$ ,  $100\ \mu\text{A} < I_L \leq 100\ \text{mA}$ ,  $T_J \leq T_{\text{JMAX}}$ .
- 8:** Output or reference voltage temperature coefficient is defined as the worst case voltage change divided by the total temperature range.
- 9:**  $V_{\text{SHUTDOWN}} \geq 2\text{V}$ ,  $V_{\text{IN}} \leq 30\text{V}$ ,  $V_{\text{OUT}} = 0$ , with Feedback pin tied to 5V Tap.

# LP2951

## ELECTRICAL CHARACTERISTICS (CONTINUED)

Electrical Characteristics: Unless otherwise indicated, $T_A = +25^\circ\text{C}$						
Parameters	Symbol	Min.	Typ.	Max.	Units	Conditions
Output Noise	$e_N$	—	430	—	$\mu\text{V}_{\text{RMS}}$	10 Hz to 100 kHz, $C_L = 1 \mu\text{F}$
		—	160	—	$\mu\text{V}_{\text{RMS}}$	10 Hz to 100 kHz, $C_L = 200 \mu\text{F}$
		—	100	—	$\mu\text{V}_{\text{RMS}}$	10 Hz to 100 kHz, $C_L = 3.3 \mu\text{F}$ , 0.01 $\mu\text{F}$ bypass Feedback to Output
Reference Voltage	$V_{\text{REF}}$	1.220	1.235	1.25	V	LP2951-02 ( $\pm 0.5\%$ )
		<b>1.200</b>	—	<b>1.260</b>	V	
		1.210	1.235	1.260	V	LP2951-03 ( $\pm 1\%$ )
		<b>1.200</b>	—	<b>1.270</b>	V	
Reference Voltage	$V_{\text{REF}}$	1.190	—	1.270	V	LP2951-02 ( $\pm 0.5\%$ ), <a href="#">Note 7</a>
		1.185	—	1.285	V	LP2951-03 ( $\pm 1\%$ ), <a href="#">Note 7</a>
Feedback Bias Current	—	—	20	40	nA	—
		—	—	60		
Reference Voltage	$V_{\text{REF}}$	—	20	—	ppm/ $^\circ\text{C}$	LP2951-02 ( $\pm 0.5\%$ ), <a href="#">Note 8</a>
		—	50	—	ppm/ $^\circ\text{C}$	LP2951-03 ( $\pm 1\%$ ), <a href="#">Note 8</a>
Feedback Bias Current Temperature Coefficient	—	—	0.1	—	nA/ $^\circ\text{C}$	
Output Leakage Current	—	—	0.01	1.00	$\mu\text{A}$	$V_{\text{OH}} = 30\text{V}$
		—	—	<b>2.00</b>	$\mu\text{A}$	

**Note 1:** Output or reference voltage temperature coefficient is defined as the worst case voltage change divided by the total temperature range.

- 2:** Regulation is measured at constant junction temperature, using pulse testing with a low duty cycle. Changes in output voltage due to heating effects are covered in the specification for thermal regulation.
- 3:** Line regulation for the LP2951 is tested at  $150^\circ\text{C}$  for  $I_L = 1 \text{ mA}$ . For  $I_L = 100 \mu\text{A}$  and  $T_J = 125^\circ\text{C}$ , line regulation is guaranteed by design to 0.2%. See Typical Performance Characteristics for line regulation versus temperature and load current.
- 4:** Dropout voltage is defined as the input to output differential at which the output voltage drops 100 mV below its nominal value measured at 1V differential. At very low values of programmed output voltage, the minimum input supply voltage of 2V (2.3V over temperature) must be taken into account.
- 5:** Thermal regulation is defined as the change in output voltage at a time T after a change in power dissipation is applied, excluding load or line regulation effects. Specifications are for a 50 mA load pulse at  $V_{\text{IN}} = 30\text{V}$  (1.25W pulse) for  $t = 10 \text{ ms}$ .
- 6:** Comparator thresholds are expressed in terms of a voltage differential at the Feedback terminal below the nominal reference voltage measured at 6V input. To express these thresholds in terms of output voltage change, multiply by the error amplifier gain  $= V_{\text{OUT}}/V_{\text{REF}} = (R1 + R2)/R2$ . For example, at a programmed output voltage of 5V, the Error output is guaranteed to go low when the output drops by  $95 \text{ mV} \times 5\text{V}/1.235\text{V} = 384 \text{ mV}$ . Thresholds remain constant as a percent of  $V_{\text{OUT}}$  as  $V_{\text{OUT}}$  is varied, with the dropout warning occurring at typically 5% below nominal, 7.5% guaranteed.
- 7:**  $V_{\text{REF}} \leq V_{\text{OUT}} \leq (V_{\text{IN}} - 1 \text{ V})$ ,  $2.3\text{V} \leq V_{\text{IN}} \leq 30\text{V}$ ,  $100 \mu\text{A} < I_L \leq 100 \text{ mA}$ ,  $T_J \leq T_{\text{JMAX}}$ .
- 8:** Output or reference voltage temperature coefficient is defined as the worst case voltage change divided by the total temperature range.
- 9:**  $V_{\text{SHUTDOWN}} \geq 2\text{V}$ ,  $V_{\text{IN}} \leq 30\text{V}$ ,  $V_{\text{OUT}} = 0$ , with Feedback pin tied to 5V Tap.



## ELECTRICAL CHARACTERISTICS (CONTINUED)

Electrical Characteristics: Unless otherwise indicated, $T_A = +25^\circ\text{C}$						
Parameters	Symbol	Min.	Typ.	Max.	Units	Conditions
Output Low Voltage (Flag)	$V_{OL}$	—	150	250	mV	$V_{IN} = 4.5\text{V}, I_{OL} = 200\mu\text{A}$
		—	—	400	mV	
Upper Threshold Voltage	—	40	60	—	mV	Note 6
		25	—	—	mV	
Lower Threshold Voltage	—	—	75	95	mV	Note 6
		—	—	140	mV	
Hysteresis	HYS	—	15	—	mV	Note 6
Input Logic Voltage	—	—	1.3	—	V	LP2951-02 ( $\pm 0.5\%$ )
		—	—	0.7	V	Low
		2.0	—	—	V	High
		—	1.3	—	V	LP2951-03 ( $\pm 1\%$ )
		—	—	0.7	V	Low
		2.0	—	—	V	High

- Note 1:** Output or reference voltage temperature coefficient is defined as the worst case voltage change divided by the total temperature range.
- 2:** Regulation is measured at constant junction temperature, using pulse testing with a low duty cycle. Changes in output voltage due to heating effects are covered in the specification for thermal regulation.
- 3:** Line regulation for the LP2951 is tested at  $150^\circ\text{C}$  for  $I_L = 1\text{ mA}$ . For  $I_L = 100\ \mu\text{A}$  and  $T_J = 125^\circ\text{C}$ , line regulation is guaranteed by design to 0.2%. See Typical Performance Characteristics for line regulation versus temperature and load current.
- 4:** Dropout voltage is defined as the input to output differential at which the output voltage drops 100 mV below its nominal value measured at 1V differential. At very low values of programmed output voltage, the minimum input supply voltage of 2V (2.3V over temperature) must be taken into account.
- 5:** Thermal regulation is defined as the change in output voltage at a time T after a change in power dissipation is applied, excluding load or line regulation effects. Specifications are for a 50 mA load pulse at  $V_{IN} = 30\text{V}$  (1.25W pulse) for  $t = 10\text{ ms}$ .
- 6:** Comparator thresholds are expressed in terms of a voltage differential at the Feedback terminal below the nominal reference voltage measured at 6V input. To express these thresholds in terms of output voltage change, multiply by the error amplifier gain  $= V_{OUT}/V_{REF} = (R1 + R2)/R2$ . For example, at a programmed output voltage of 5V, the Error output is guaranteed to go low when the output drops by  $95\text{ mV} \times 5\text{V}/1.235\text{V} = 384\text{ mV}$ . Thresholds remain constant as a percent of  $V_{OUT}$  as  $V_{OUT}$  is varied, with the dropout warning occurring at typically 5% below nominal, 7.5% guaranteed.
- 7:**  $V_{REF} \leq V_{OUT} \leq (V_{IN} - 1\text{ V}), 2.3\text{V} \leq V_{IN} \leq 30\text{V}, 100\ \mu\text{A} < I_L \leq 100\text{ mA}, T_J \leq T_{JMAX}$ .
- 8:** Output or reference voltage temperature coefficient is defined as the worst case voltage change divided by the total temperature range.
- 9:**  $V_{SHUTDOWN} \geq 2\text{V}, V_{IN} \leq 30\text{V}, V_{OUT} = 0$ , with Feedback pin tied to 5V Tap.

# LP2951

## ELECTRICAL CHARACTERISTICS (CONTINUED)

Electrical Characteristics: Unless otherwise indicated, $T_A = +25^\circ\text{C}$						
Parameters	Symbol	Min.	Typ.	Max.	Units	Conditions
Shutdown Input Current	$I_{\text{SHDN}}$	—	30	50	$\mu\text{A}$	$V_{\text{SHUTDOWN}} = 2.4\text{V}$
		—	—	100	$\mu\text{A}$	
		—	450	600	$\mu\text{A}$	$V_{\text{SHUTDOWN}} = 30\text{V}$
		—	—	700	$\mu\text{A}$	
Regulator Output Current in Shutdown	—	—	3	10	$\mu\text{A}$	Note 9
		—	—	20	$\mu\text{A}$	

- Note 1:** Output or reference voltage temperature coefficient is defined as the worst case voltage change divided by the total temperature range.
- 2:** Regulation is measured at constant junction temperature, using pulse testing with a low duty cycle. Changes in output voltage due to heating effects are covered in the specification for thermal regulation.
- 3:** Line regulation for the LP2951 is tested at  $150^\circ\text{C}$  for  $I_L = 1\text{ mA}$ . For  $I_L = 100\ \mu\text{A}$  and  $T_J = 125^\circ\text{C}$ , line regulation is guaranteed by design to 0.2%. See Typical Performance Characteristics for line regulation versus temperature and load current.
- 4:** Dropout voltage is defined as the input to output differential at which the output voltage drops 100 mV below its nominal value measured at 1V differential. At very low values of programmed output voltage, the minimum input supply voltage of 2V (2.3V over temperature) must be taken into account.
- 5:** Thermal regulation is defined as the change in output voltage at a time T after a change in power dissipation is applied, excluding load or line regulation effects. Specifications are for a 50 mA load pulse at  $V_{\text{IN}} = 30\text{V}$  (1.25W pulse) for  $t = 10\text{ ms}$ .
- 6:** Comparator thresholds are expressed in terms of a voltage differential at the Feedback terminal below the nominal reference voltage measured at 6V input. To express these thresholds in terms of output voltage change, multiply by the error amplifier gain  $= V_{\text{OUT}}/V_{\text{REF}} = (R1 + R2)/R2$ . For example, at a programmed output voltage of 5V, the Error output is guaranteed to go low when the output drops by  $95\text{ mV} \times 5\text{V}/1.235\text{V} = 384\text{ mV}$ . Thresholds remain constant as a percent of  $V_{\text{OUT}}$  as  $V_{\text{OUT}}$  is varied, with the dropout warning occurring at typically 5% below nominal, 7.5% guaranteed.
- 7:**  $V_{\text{REF}} \leq V_{\text{OUT}} \leq (V_{\text{IN}} - 1\text{ V})$ ,  $2.3\text{V} \leq V_{\text{IN}} \leq 30\text{V}$ ,  $100\ \mu\text{A} < I_L \leq 100\text{ mA}$ ,  $T_J \leq T_{\text{JMAX}}$ .
- 8:** Output or reference voltage temperature coefficient is defined as the worst case voltage change divided by the total temperature range.
- 9:**  $V_{\text{SHUTDOWN}} \geq 2\text{V}$ ,  $V_{\text{IN}} \leq 30\text{V}$ ,  $V_{\text{OUT}} = 0$ , with Feedback pin tied to 5V Tap.

## TEMPERATURE SPECIFICATIONS (Note 1)

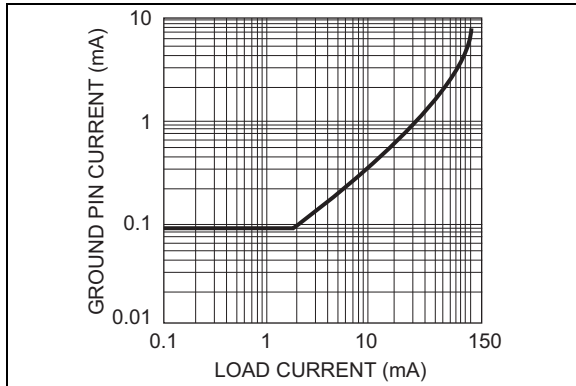
Parameters	Sym.	Min.	Typ.	Max.	Units	Conditions
<b>Temperature Ranges</b>						
Lead Temperature Range	—	—	260	—	°C	—
Junction Operating Temperature	$T_J$	-40	—	+125	°C	—
Storage Temperature Range	$T_A$	-65	—	+125	°C	—
<b>Package Thermal Resistances</b>						
Thermal Resistance, DIP Package	$\theta_{JA}$	—	105	—	°C/W	Soldered directly to a PC board
	$\theta_{JC}$	—	40	—	°C/W	—
Thermal Resistance, SOIC Package	$\theta_{JA}$	—	160	—	°C/W	Typically mounting on a 1" square copper-clad FR4 circuit board
	$\theta_{JC}$	—	25	—	°C/W	—

**Note 1:** The maximum allowable power dissipation is a function of ambient temperature, the maximum allowable junction temperature and the thermal resistance from junction to air (i.e.,  $T_A$ ,  $T_J$ ,  $\theta_{JA}$ ). Exceeding the maximum allowable power dissipation will cause the device operating junction temperature to exceed the maximum +125°C rating. Sustained junction temperatures above +125°C can impact the device reliability.

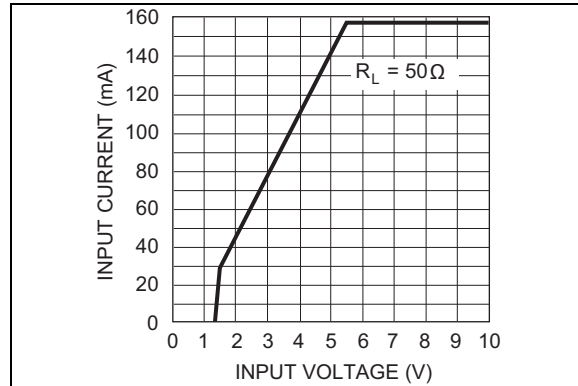
# LP2951

## 2.0 TYPICAL PERFORMANCE CURVES

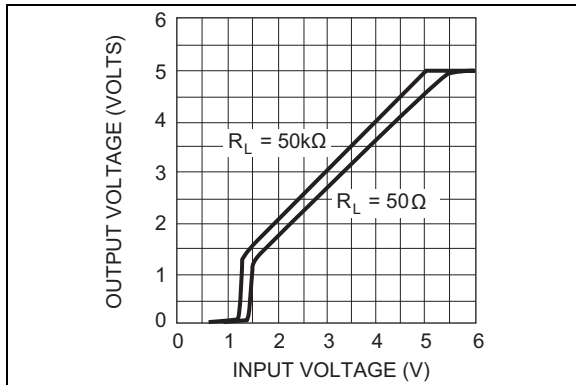
**Note:** The graphs and tables provided following this note are a statistical summary based on a limited number of samples and are provided for informational purposes only. The performance characteristics listed herein are not tested or guaranteed. In some graphs or tables, the data presented may be outside the specified operating range (e.g., outside specified power supply range) and therefore outside the warranted range.



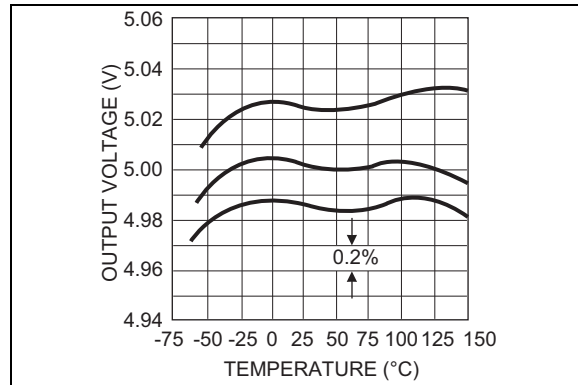
**FIGURE 2-1:** Quiescent Current.



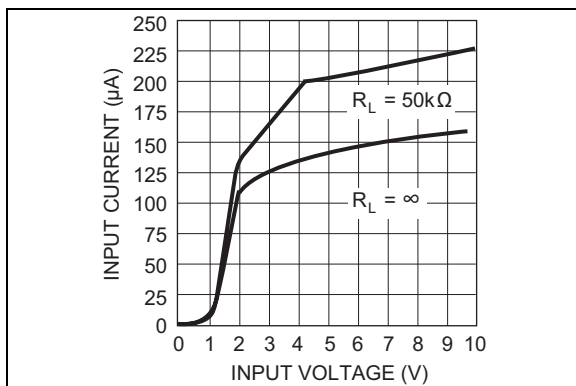
**FIGURE 2-4:** Input Current.



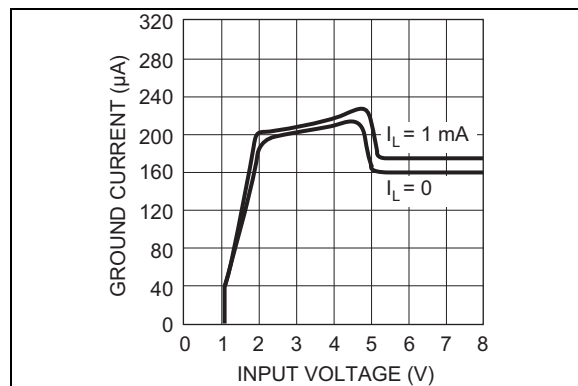
**FIGURE 2-2:** Dropout Characteristics.



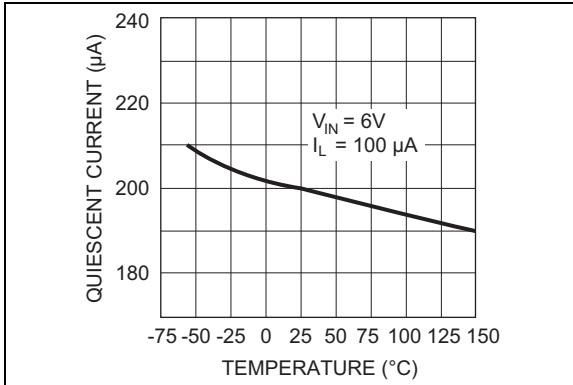
**FIGURE 2-5:** Output Voltage vs. Temperature of 3 Representative Units.



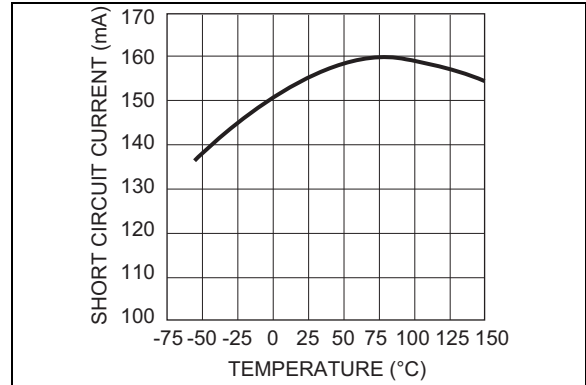
**FIGURE 2-3:** Input Current.



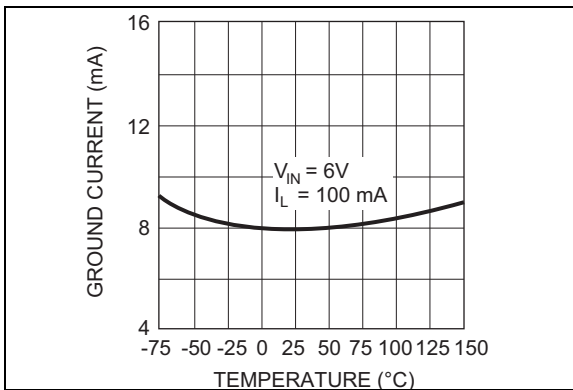
**FIGURE 2-6:** Ground Current.



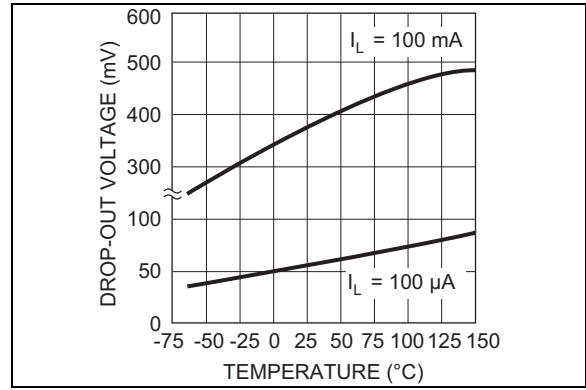
**FIGURE 2-7:** Quiescent Current.



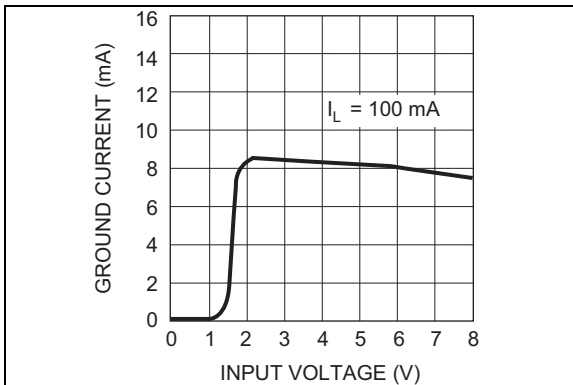
**FIGURE 2-10:** Short Circuit Current.



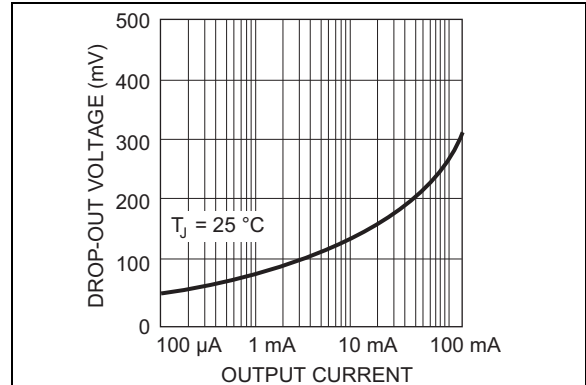
**FIGURE 2-8:** Ground Current.



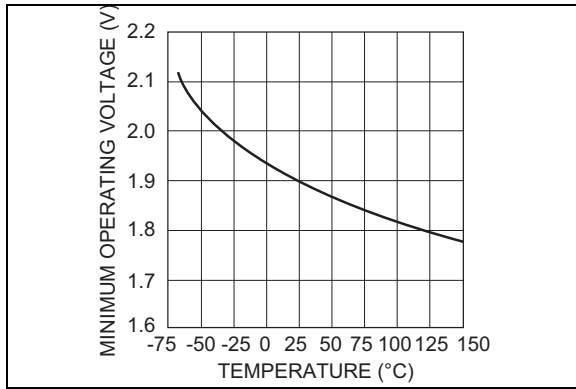
**FIGURE 2-11:** Dropout Voltage.



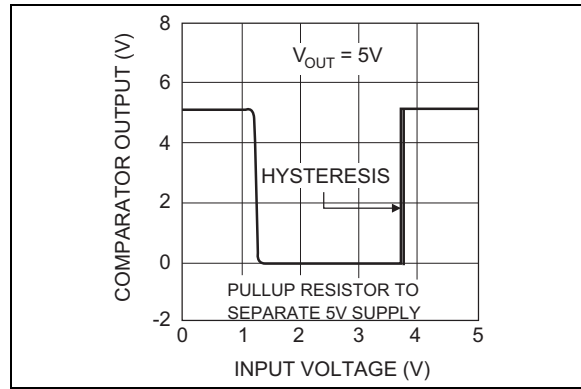
**FIGURE 2-9:** Ground Current.



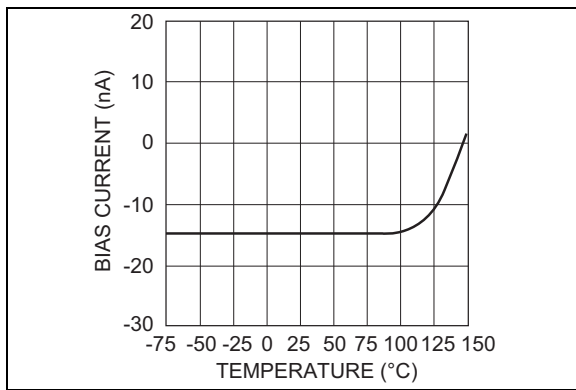
**FIGURE 2-12:** Dropout Voltage.



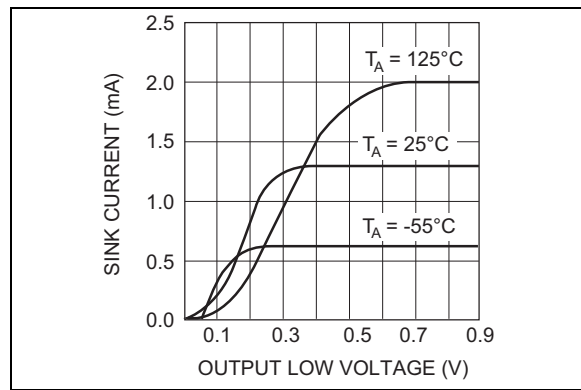
**FIGURE 2-13:** Minimum Operating Voltage.



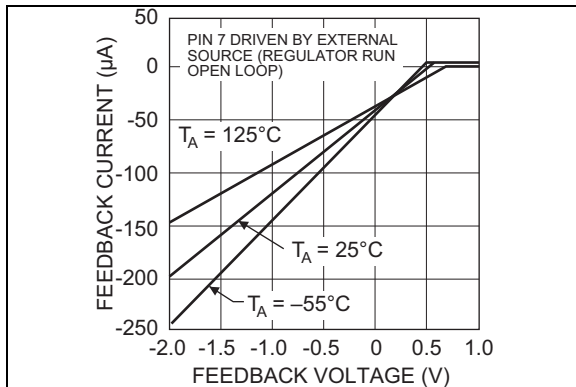
**FIGURE 2-16:** Error Comparator Output.



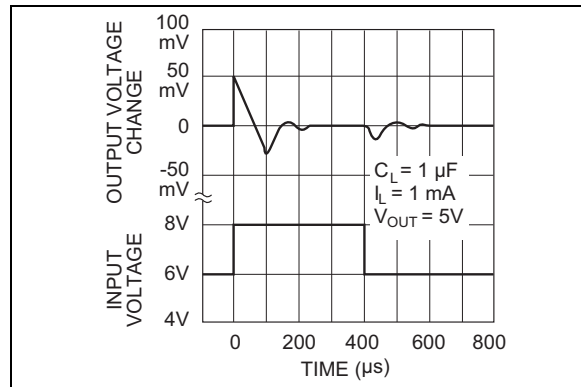
**FIGURE 2-14:** Feedback Bias Current.



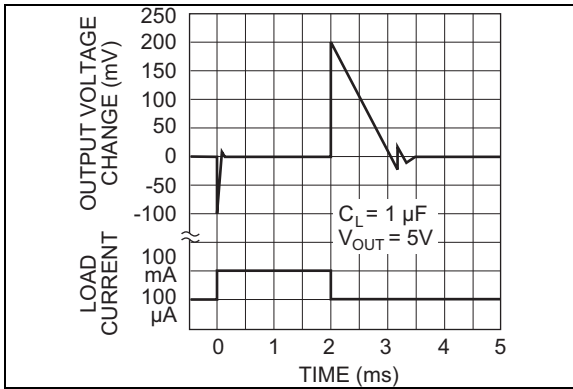
**FIGURE 2-17:** Comparator Sink Current.



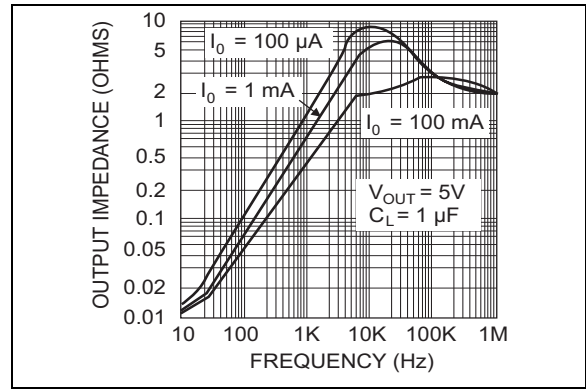
**FIGURE 2-15:** Feedback Pin Current.



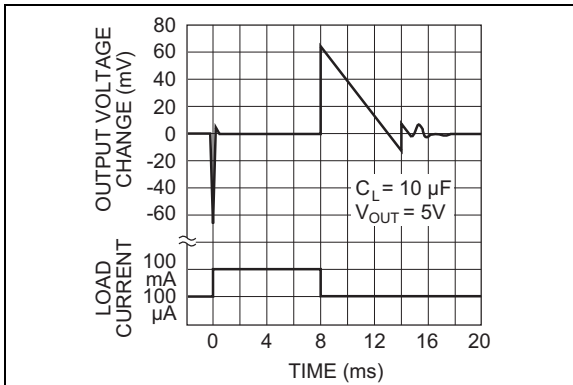
**FIGURE 2-18:** Line Transient Response.



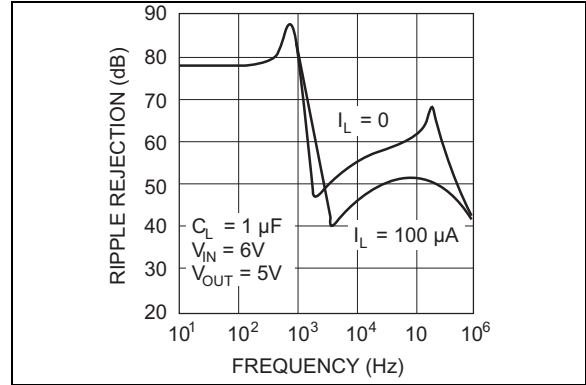
**FIGURE 2-19:** Load Transient Response.



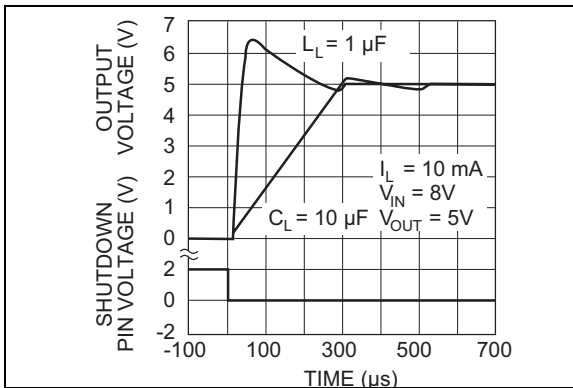
**FIGURE 2-22:** Output Impedance.



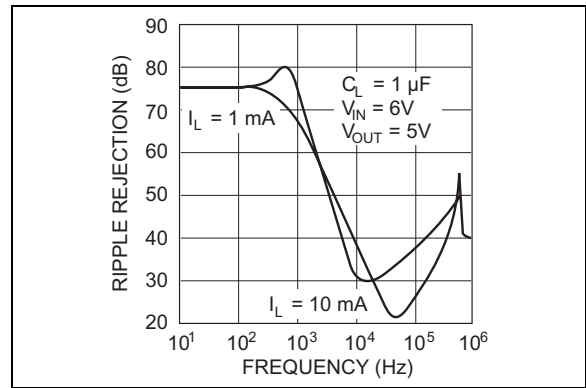
**FIGURE 2-20:** Load Transient Response.



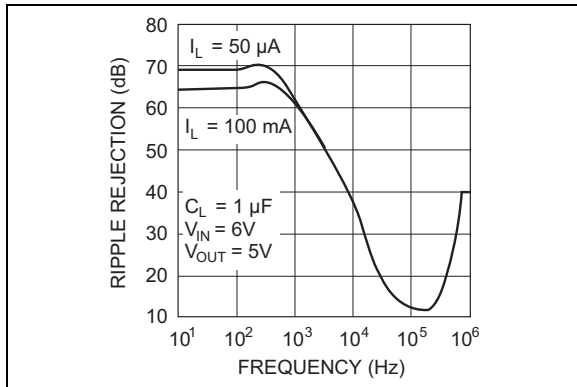
**FIGURE 2-23:** Ripple Rejection.



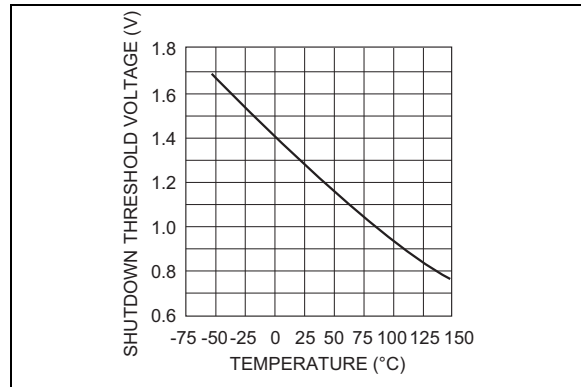
**FIGURE 2-21:** Enable Transient.



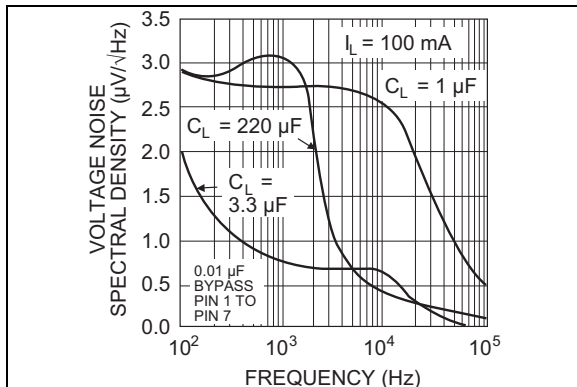
**FIGURE 2-24:** Ripple Rejection.



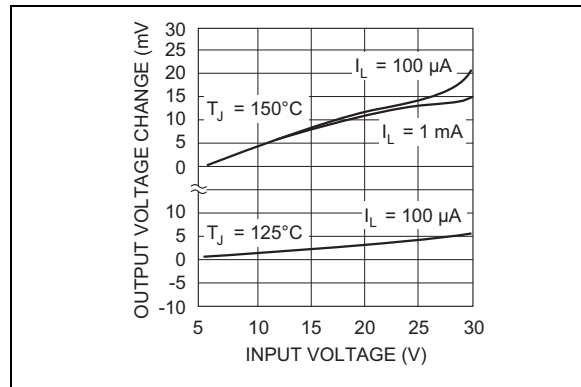
**FIGURE 2-25:** *Ripple Rejection.*



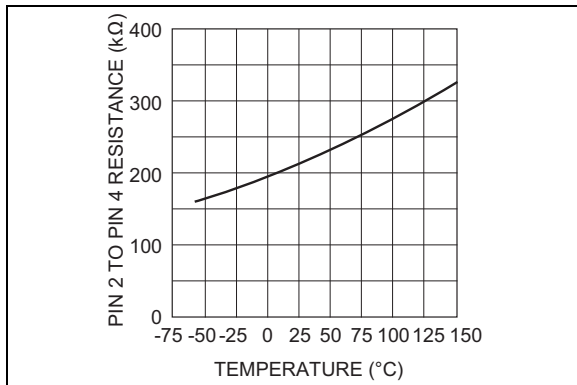
**FIGURE 2-28:** *Shutdown Threshold Voltage.*



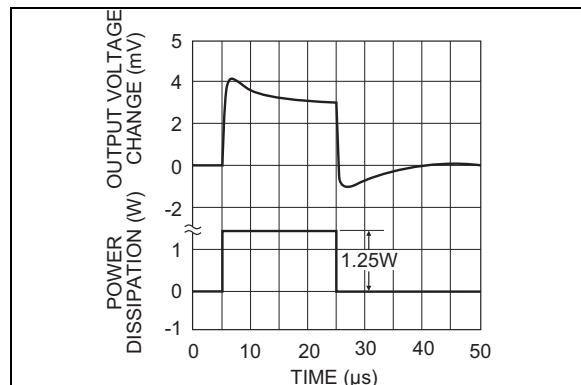
**FIGURE 2-26:** *Output Noise.*



**FIGURE 2-29:** *Line Regulation.*



**FIGURE 2-27:** *Divider Resistance.*



**FIGURE 2-30:** *Thermal Response.*



## 3.0 PIN DESCRIPTIONS

The descriptions of the pins are listed in [Table 3-1](#).

**TABLE 3-1: DIP AND SOIC PIN FUNCTION TABLE**

Pin Number	Symbol	Description
1	$V_{OUT}$	Regulated voltage output.
2	SENSE	Output Voltage Sense.
3	SHDN	Shutdown Input.
4	GND	Ground Terminal.
5	ERROR	Error Output.
6	5V TAP	Internal Resistor Divider for 5V Output.
7	FB	Voltage Feedback Input.
8	$V_{IN}$	Unregulated Supply Voltage.

## 4.0 APPLICATION INFORMATION

### 4.1 External Capacitors

A 1.0  $\mu\text{F}$  (or greater) capacitor is required between the LP2951 output and ground to prevent oscillations due to instability. Most types of tantalum or aluminum electrolytics will be adequate; film types will work, but are costly and therefore not recommended. Many aluminum electrolytics have electrolytes that freeze at about  $-30^{\circ}\text{C}$ , so solid tantalum capacitors are recommended for operation below  $-25^{\circ}\text{C}$ . The important parameters of the capacitor are an effective series resistance of about  $5\Omega$  or less and a resonant frequency above 500 kHz. The value of this capacitor may be increased without limit.

At lower values of output current, less output capacitance is required for output stability. The capacitor can be reduced to 0.33  $\mu\text{F}$  for current below 10 mA or 0.1  $\mu\text{F}$  for currents below 1 mA. Using the 8-pin versions at voltages below 5V runs the error amplifier at lower gains so that more output capacitance is needed. For the worst-case situation of a 100 mA load at 1.23V output (Output shorted to Feedback) a 3.3  $\mu\text{F}$  (or greater) capacitor should be used.

When the 5V Tap pin and Feedback pin are connected together for 5V output voltage, the LP2951 will remain stable and in regulation with no load in addition to the internal voltage divider, unlike many other voltage regulators. This is especially important in CMOS RAM keep-alive applications. When setting the output voltage of the LP2951 with external resistors, a minimum load of 1  $\mu\text{A}$  is recommended.

A 0.1  $\mu\text{F}$  capacitor should be placed from the LP2951 input to ground if there is more than 10 inches of wire between the input and the AC filter capacitor or if a battery is used as the input.

Stray capacitance to the LP2951 Feedback terminal (pin 7) can cause instability. This may especially be a problem when using high value external resistors to set the output voltage. Adding a 100 pF capacitor between Output and Feedback and increasing the output capacitor to at least 3.3  $\mu\text{F}$  will remedy this.

### 4.2 Error Detection Comparator Output

A logic low output will be produced by the comparator whenever the LP2951 output falls out of regulation by more than approximately 5%. This figure is the comparator's built-in offset of about 60mV divided by the 1.235V reference voltage. (Refer to the [Functional Block Diagram](#)). This trip level remains "5% below normal" regardless of the programmed output voltage of the LP2951. For example, the error flag trip level is typically 4.75V for a 5V output or 11.4V for a 12V

output. The out of regulation condition may be due either to low input voltage, current limiting, or thermal limiting.

[Figure 4-1](#) is a timing diagram depicting the ERROR signal and the regulated output voltage as the LP2951 input is ramped up and down. The ERROR signal becomes valid (low) at about 1.3V input. It goes high at about 5V input (the input voltage at which  $V_{\text{OUT}} = 4.75\text{V}$ ). Because the LP2951's dropout voltage is load-dependent (see curve in [Typical Performance Curves](#)), the input voltage trip point (about 5V) will vary with the load current. The output voltage trip point (approximately 4.75V) does not vary with load.

The error comparator has an open-collector output which requires an external pull-up resistor. Depending on system requirements, this resistor may be returned to the 5V output or some other supply voltage. In determining a value for this resistor, note that while the output is rated to sink 400  $\mu\text{A}$ , this sink current adds to battery drain in a low battery condition. Suggested values range from 100 k $\Omega$  to 1 M $\Omega$ . The resistor is not required if this output is unused.

### 4.3 Programming the Output Voltage

The LP2951 may be pin-strapped for 5V output voltage using its internal voltage divider, by tying Pin 1 ( $V_{\text{OUT}}$ ) and Pin 2 (SENSE) together, as well as tying Pin 7 (Feedback) and Pin 6 (5V TAP) together. Alternatively, it may be programmed for any output voltage between its 1.235V reference and its 30V maximum rating. An external pair of resistors is required, as shown in [Figure 4-2](#).

The complete equation for the output voltage is:

#### EQUATION 4-1:

$$V_{\text{OUT}} = V_{\text{REF}} \times \left\{ 1 + \frac{R_1}{R_2} \right\} + I_{\text{FB}} R_2$$

Where:

- $V_{\text{REF}}$  = the nominal 1.235 reference voltage
- $I_{\text{FB}}$  = the feedback pin bias current, nominally 20 nA

The minimum recommended load current of 1  $\mu\text{A}$  forces an upper limit of 1.2 M $\Omega$  on the value of R2, if the regulator must work with no load (a condition often found in CMOS in standby),  $I_{\text{FB}}$  will produce a 2% typical error in  $V_{\text{OUT}}$  which may be eliminated at room temperature by trimming R1. For better accuracy, choosing R2 = 100 k $\Omega$  reduces this error to 0.17% while increasing the resistor program current to 12  $\mu\text{A}$ . Since the LP2951 typically draws 60  $\mu\text{A}$  at no load with Pin 2 open-circuited, this is a small price to pay.

## 4.4 Reducing Output Noise

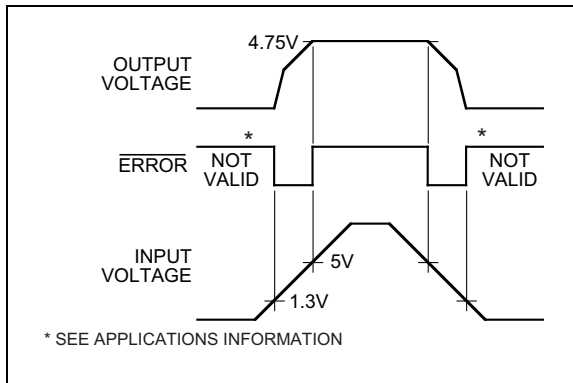
In reference applications it may be advantageous to reduce the AC noise present at the output. One method is to reduce the regulator bandwidth by increasing the size of the output capacitor. This method is relatively inefficient, as increasing the capacitor from 1  $\mu\text{F}$  to 220  $\mu\text{F}$  only decreases the noise from 430  $\mu\text{V}$  to 160  $\mu\text{V}_{\text{rms}}$  for a 100 kHz bandwidth at 5V output.

Noise can be reduced fourfold by a bypass capacitor across R1, since it reduces the high frequency gain from 4 to unity. Pick the resulting frequency from [Equation 4-2](#):

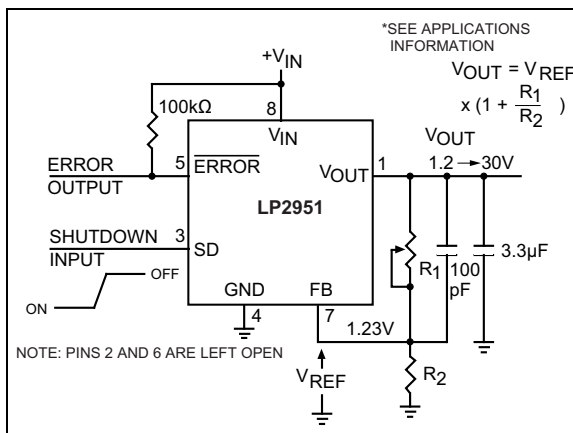
### EQUATION 4-2:

$$C_{BYPASS} = \frac{1}{2\pi R_1 \cdot 200\text{Hz}}$$

or about 0.01  $\mu\text{F}$ . When doing this, the output capacitor must be increased to 3.3  $\mu\text{F}$  to maintain stability. These changes reduce the output noise from 430  $\mu\text{V}$  to 100  $\mu\text{V}_{\text{rms}}$  for a 100 kHz bandwidth at 5V output. With the bypass capacitor added, noise no longer scales with output voltage so that improvements are more dramatic at higher output voltages.

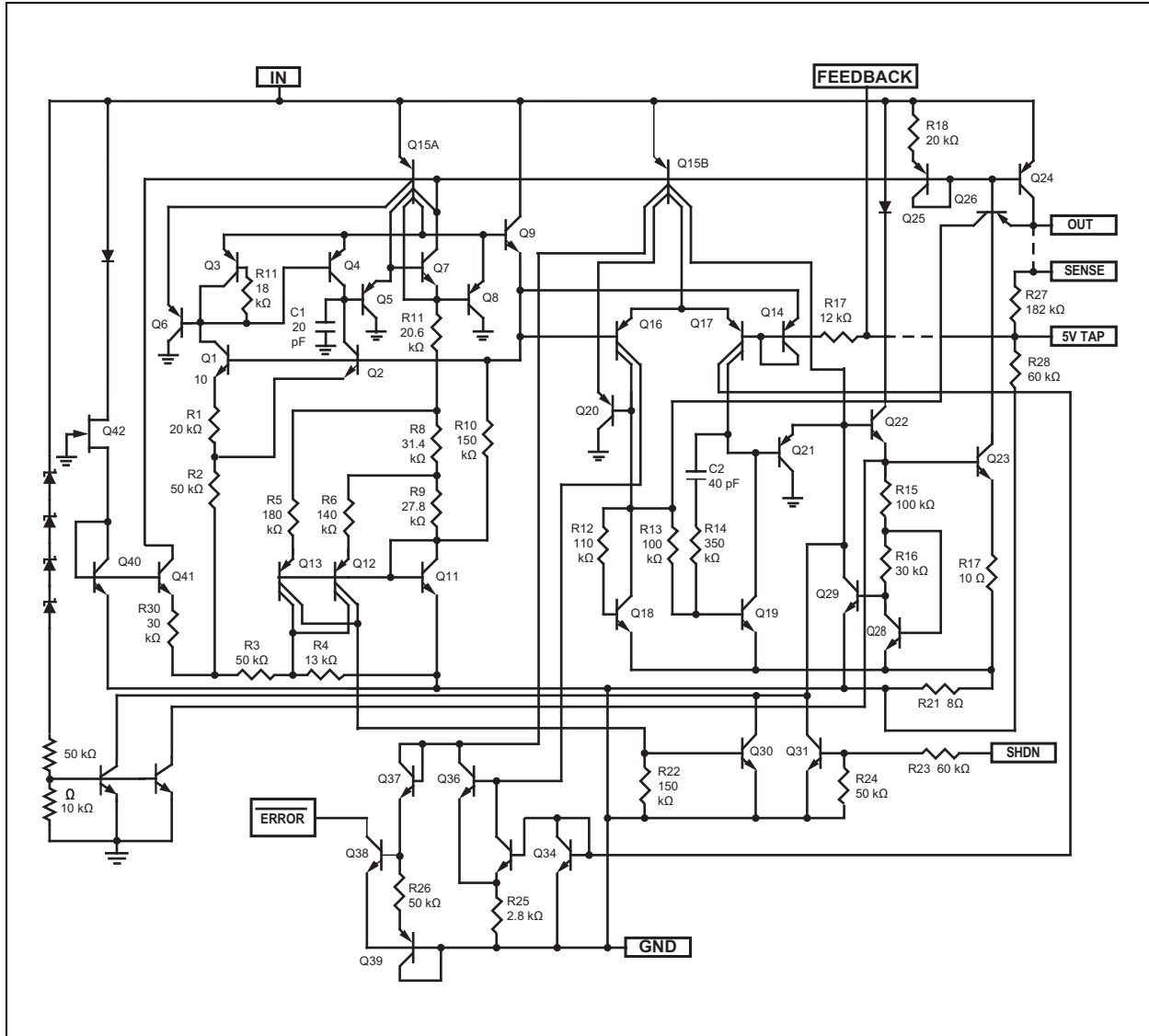


**FIGURE 4-1:** ERROR Output Timing.



**FIGURE 4-2:** Adjustable Regulator.

# LP2951

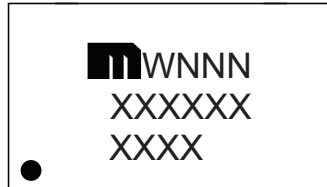


**FIGURE 4-3:** Schematic Diagram.

## 5.0 PACKAGING INFORMATION

### 5.1 Package Marking Information

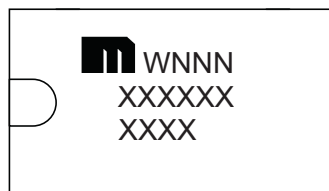
8-Pin SOIC\*



Example



8-Pin Plastic DIP\*



Example



<b>Legend:</b>	XX...X	Product code or customer-specific information
	Y	Year code (last digit of calendar year)
	YY	Year code (last 2 digits of calendar year)
	WW	Week code (week of January 1 is week '01')
	NNN	Alphanumeric traceability code
	(e3)	Pb-free JEDEC® designator for Matte Tin (Sn)
	*	This package is Pb-free. The Pb-free JEDEC designator ((e3)) can be found on the outer packaging for this package.
	•, ▲, ▼	Pin one index is identified by a dot, delta up, or delta down (triangle mark).
<b>Note:</b>	In the event the full Microchip part number cannot be marked on one line, it will be carried over to the next line, thus limiting the number of available characters for customer-specific information. Package may or may not include the corporate logo.	
	Underbar ( _ ) and/or Overbar ( ¯ ) symbol may not be to scale.	

**Note:** If the full seven-character YYWWNNN code cannot fit on the package, the following truncated codes are used based on the available marking space:  
 6 Characters = YWWNNN; 5 Characters = WWNNN; 4 Characters = WNNN; 3 Characters = NNN;  
 2 Characters = NN; 1 Character = N

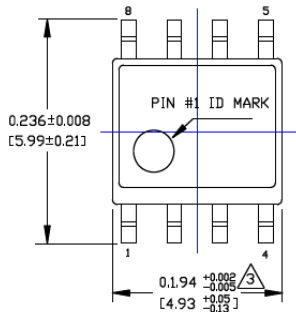
# LP2951

## 8-Lead SOIC Package Outline and Recommended Land Pattern

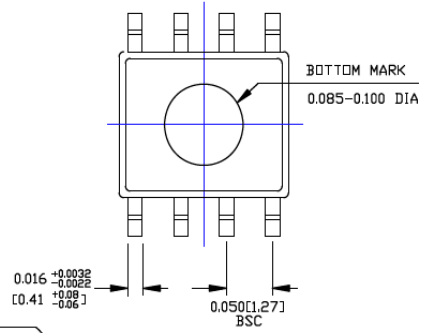
**TITLE**

8 LEAD SOICN PACKAGE OUTLINE & RECOMMENDED LAND PATTERN

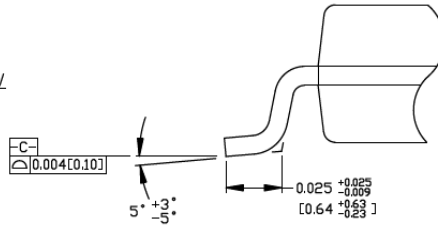
DRAWING #	SOICN-8LD-PL-1	UNIT	INCH [MM]
-----------	----------------	------	-----------



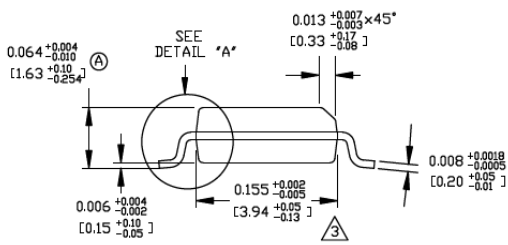
TOP VIEW



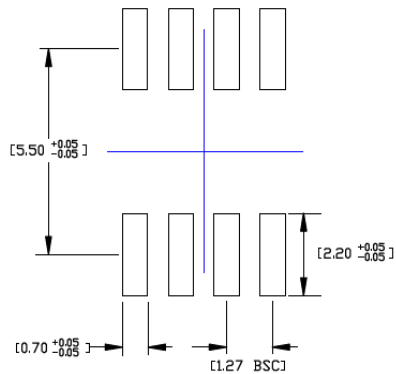
BOTTOM VIEW



DETAIL "A"



END VIEW



RECOMMENDED LAND PATTERN

**NOTES:**

1. DIMENSIONS ARE IN INCHES[MM].
2. CONTROLLING DIMENSION: INCHES.
3. DIMENSION DOES NOT INCLUDE MOLD FLASH OR PROTRUSIONS, EITHER OF WHICH SHALL NOT EXCEED 0.010[0.25] PER SIDE.

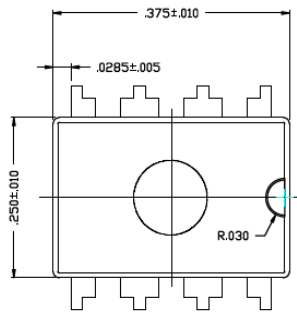
Note: For the most current package drawings, please see the Microchip Packaging Specification located at <http://www.microchip.com/packaging>.

## 8-Lead PDIP Package Outline and Recommended Land Pattern

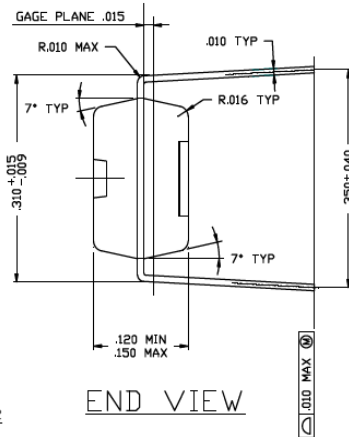
**TITLE**

8 LEAD PDIP PACKAGE OUTLINE & RECOMMENDED LAND PATTERN

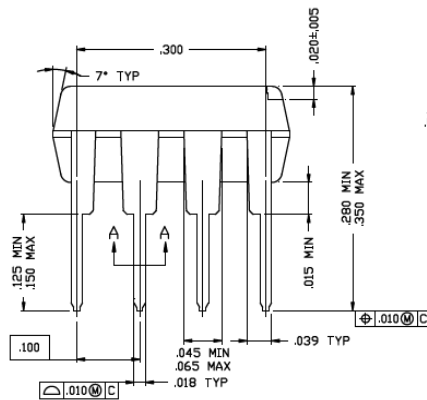
<b>DRAWING #</b>	PDIP-8LD-PL-1	<b>UNIT</b>	INCH
<b>Lead Frame</b>	Copper	<b>Lead Finish</b>	Matte Tin



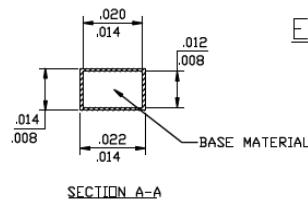
TOP VIEW



END VIEW



SIDE VIEW



SECTION A-A

Note: For the most current package drawings, please see the Microchip Packaging Specification located at <http://www.microchip.com/packaging>.

# LP2951

---

---

NOTES:



## APPENDIX A: REVISION HISTORY

### Revision A (May 2017)

- Converted Micrel document LP2951 to Microchip data sheet template DS20005736A.
- Minor grammatical text changes throughout.

### Revision B (February 2022)

- Updated [Package Marking Information](#) drawing to reflect the most current marking information.
- Added symbol information to the Symbol column of the [Electrical Characteristics](#) table.
- Minor text changes throughout for clarity.
- Added Media Type information to the [Product Identification System](#) section.
- Removed examples in the [Electrical Characteristics](#) table pertaining to the no longer manufactured 4.8V option.

# LP2951

---

NOTES:

## PRODUCT IDENTIFICATION SYSTEM

To order or obtain information, e.g., on pricing or delivery, contact your local Microchip representative or sales office.

<u>Part No.</u>	-XX	Δ	Δ	-XX	<b>Examples:</b>
Device	Accuracy	Temperature Range	Package	Media Type	
<b>Device:</b>	LP2951:	100 mA Low-Dropout Voltage Regulator			a) LP2951-02YM-TR: 100 mA Low-Dropout Voltage Regulator, 0.5% Accuracy, -40°C to +85°C (RoHS Compliant), 8-Lead SOIC, 2500/Reel
<b>Accuracy:</b>	02 = 0.5% 03 = 1.0%				b) LP2951-03YM: 100 mA Low-Dropout Voltage Regulator, 1.0% Accuracy, -40°C to +85°C (RoHS Compliant), 8-Lead SOIC, 95/Tube
<b>Temperature Range:</b>	Y = -40°C to +85°C (RoHS Compliant)				c) LP2951-02YN: 100 mA Low-Dropout Voltage Regulator, 0.5% Accuracy, -40°C to +85°C (RoHS Compliant), 8-Lead PDIP, 50/Tube
<b>Package:</b>	M = 8-pin SOIC N = 8-pin PDIP				<b>Note 1:</b> Tape and Reel identifier only appears in the catalog part number description. This identifier is used for ordering purposes and is not printed on the device package. Check with your Microchip Sales Office for package availability with the Tape and Reel option.
<b>Media Type:</b>	<blank>= 50/Tube (PDIP option only) <blank>= 95/Tube (SOIC option only) TR = 2500/Reel (SOIC option only)				

# LP2951

---

---

NOTES:

---

---

**Note the following details of the code protection feature on Microchip products:**

- Microchip products meet the specifications contained in their particular Microchip Data Sheet.
- Microchip believes that its family of products is secure when used in the intended manner, within operating specifications, and under normal conditions.
- Microchip values and aggressively protects its intellectual property rights. Attempts to breach the code protection features of Microchip product is strictly prohibited and may violate the Digital Millennium Copyright Act.
- Neither Microchip nor any other semiconductor manufacturer can guarantee the security of its code. Code protection does not mean that we are guaranteeing the product is “unbreakable”. Code protection is constantly evolving. Microchip is committed to continuously improving the code protection features of our products.

---

This publication and the information herein may be used only with Microchip products, including to design, test, and integrate Microchip products with your application. Use of this information in any other manner violates these terms. Information regarding device applications is provided only for your convenience and may be superseded by updates. It is your responsibility to ensure that your application meets with your specifications. Contact your local Microchip sales office for additional support or, obtain additional support at <https://www.microchip.com/en-us/support/design-help/client-support-services>.

THIS INFORMATION IS PROVIDED BY MICROCHIP "AS IS". MICROCHIP MAKES NO REPRESENTATIONS OR WARRANTIES OF ANY KIND WHETHER EXPRESS OR IMPLIED, WRITTEN OR ORAL, STATUTORY OR OTHERWISE, RELATED TO THE INFORMATION INCLUDING BUT NOT LIMITED TO ANY IMPLIED WARRANTIES OF NON-INFRINGEMENT, MERCHANTABILITY, AND FITNESS FOR A PARTICULAR PURPOSE, OR WARRANTIES RELATED TO ITS CONDITION, QUALITY, OR PERFORMANCE.

IN NO EVENT WILL MICROCHIP BE LIABLE FOR ANY INDIRECT, SPECIAL, PUNITIVE, INCIDENTAL, OR CONSEQUENTIAL LOSS, DAMAGE, COST, OR EXPENSE OF ANY KIND WHATSOEVER RELATED TO THE INFORMATION OR ITS USE, HOWEVER CAUSED, EVEN IF MICROCHIP HAS BEEN ADVISED OF THE POSSIBILITY OR THE DAMAGES ARE FORESEEABLE. TO THE FULLEST EXTENT ALLOWED BY LAW, MICROCHIP'S TOTAL LIABILITY ON ALL CLAIMS IN ANY WAY RELATED TO THE INFORMATION OR ITS USE WILL NOT EXCEED THE AMOUNT OF FEES, IF ANY, THAT YOU HAVE PAID DIRECTLY TO MICROCHIP FOR THE INFORMATION.

Use of Microchip devices in life support and/or safety applications is entirely at the buyer's risk, and the buyer agrees to defend, indemnify and hold harmless Microchip from any and all damages, claims, suits, or expenses resulting from such use. No licenses are conveyed, implicitly or otherwise, under any Microchip intellectual property rights unless otherwise stated.

For information regarding Microchip's Quality Management Systems, please visit [www.microchip.com/quality](http://www.microchip.com/quality).

**Trademarks**

The Microchip name and logo, the Microchip logo, Adaptec, AnyRate, AVR, AVR logo, AVR Freaks, BesTime, BitCloud, CryptoMemory, CryptoRF, dsPIC, flexPWR, HELDO, IGLOO, JukeBlox, KeeLoq, Kleer, LANCheck, LinkMD, maXStylus, maXTouch, MediaLB, megaAVR, Microsemi, Microsemi logo, MOST, MOST logo, MPLAB, OptoLyzer, PIC, picoPower, PICSTART, PIC32 logo, PolarFire, Prochip Designer, QTouch, SAM-BA, SenGenuity, SpyNIC, SST, SST Logo, SuperFlash, Symmetricom, SyncServer, Tachyon, TimeSource, tinyAVR, UNI/O, Vectron, and XMEGA are registered trademarks of Microchip Technology Incorporated in the U.S.A. and other countries.

AgileSwitch, APT, ClockWorks, The Embedded Control Solutions Company, EtherSynch, Flashtec, Hyper Speed Control, HyperLight Load, IntelliMOS, Libero, motorBench, mTouch, Powermite 3, Precision Edge, ProASIC, ProASIC Plus, ProASIC Plus logo, QuietWire, SmartFusion, SyncWorld, Temux, TimeCesium, TimeHub, TimePictra, TimeProvider, TrueTime, WinPath, and ZL are registered trademarks of Microchip Technology Incorporated in the U.S.A.

Adjacent Key Suppression, AKS, Analog-for-the-Digital Age, Any Capacitor, AnyIn, AnyOut, Augmented Switching, BlueSky, BodyCom, CodeGuard, CryptoAuthentication, CryptoAutomotive, CryptoCompanion, CryptoController, dsPICDEM, dsPICDEM.net, Dynamic Average Matching, DAM, ECAN, Espresso T1S, EtherGREEN, GridTime, IdealBridge, In-Circuit Serial Programming, ICSP, INICnet, Intelligent Paralleling, Inter-Chip Connectivity, JitterBlocker, Knob-on-Display, maxCrypto, maxView, memBrain, Mindi, MiWi, MPASM, MPF, MPLAB Certified logo, MPLIB, MPLINK, MultiTRAK, NetDetach, NVM Express, NVMe, Omniscient Code Generation, PICDEM, PICDEM.net, PICkit, PICtail, PowerSmart, PureSilicon, QMatrix, REAL ICE, Ripple Blocker, RTAX, RTG4, SAM-ICE, Serial Quad I/O, simpleMAP, SimpliPHY, SmartBuffer, SmartHLS, SMART-I.S., storClad, SQL, SuperSwitcher, SuperSwitcher II, Switchtec, SynchroPHY, Total Endurance, TSHARC, USBCheck, VariSense, VectorBlox, VeriPHY, ViewSpan, WiperLock, XpressConnect, and ZENA are trademarks of Microchip Technology Incorporated in the U.S.A. and other countries.

SQTP is a service mark of Microchip Technology Incorporated in the U.S.A.

The Adaptec logo, Frequency on Demand, Silicon Storage Technology, Symmcom, and Trusted Time are registered trademarks of Microchip Technology Inc. in other countries.

GestIC is a registered trademark of Microchip Technology Germany II GmbH & Co. KG, a subsidiary of Microchip Technology Inc., in other countries.

All other trademarks mentioned herein are property of their respective companies.

© 2017 - 2022, Microchip Technology Incorporated and its subsidiaries.

All Rights Reserved.

ISBN: 978-1-5224-9781-3



# MICROCHIP

## Worldwide Sales and Service

### AMERICAS

**Corporate Office**  
2355 West Chandler Blvd.  
Chandler, AZ 85224-6199  
Tel: 480-792-7200  
Fax: 480-792-7277  
Technical Support:  
<http://www.microchip.com/support>  
Web Address:  
[www.microchip.com](http://www.microchip.com)

**Atlanta**  
Duluth, GA  
Tel: 678-957-9614  
Fax: 678-957-1455

**Austin, TX**  
Tel: 512-257-3370

**Boston**  
Westborough, MA  
Tel: 774-760-0087  
Fax: 774-760-0088

**Chicago**  
Itasca, IL  
Tel: 630-285-0071  
Fax: 630-285-0075

**Dallas**  
Addison, TX  
Tel: 972-818-7423  
Fax: 972-818-2924

**Detroit**  
Novi, MI  
Tel: 248-848-4000

**Houston, TX**  
Tel: 281-894-5983

**Indianapolis**  
Noblesville, IN  
Tel: 317-773-8323  
Fax: 317-773-5453  
Tel: 317-536-2380

**Los Angeles**  
Mission Viejo, CA  
Tel: 949-462-9523  
Fax: 949-462-9608  
Tel: 951-273-7800

**Raleigh, NC**  
Tel: 919-844-7510

**New York, NY**  
Tel: 631-435-6000

**San Jose, CA**  
Tel: 408-735-9110  
Tel: 408-436-4270

**Canada - Toronto**  
Tel: 905-695-1980  
Fax: 905-695-2078

### ASIA/PACIFIC

**Australia - Sydney**  
Tel: 61-2-9868-6733

**China - Beijing**  
Tel: 86-10-8569-7000

**China - Chengdu**  
Tel: 86-28-8665-5511

**China - Chongqing**  
Tel: 86-23-8980-9588

**China - Dongguan**  
Tel: 86-769-8702-9880

**China - Guangzhou**  
Tel: 86-20-8755-8029

**China - Hangzhou**  
Tel: 86-571-8792-8115

**China - Hong Kong SAR**  
Tel: 852-2943-5100

**China - Nanjing**  
Tel: 86-25-8473-2460

**China - Qingdao**  
Tel: 86-532-8502-7355

**China - Shanghai**  
Tel: 86-21-3326-8000

**China - Shenyang**  
Tel: 86-24-2334-2829

**China - Shenzhen**  
Tel: 86-755-8864-2200

**China - Suzhou**  
Tel: 86-186-6233-1526

**China - Wuhan**  
Tel: 86-27-5980-5300

**China - Xian**  
Tel: 86-29-8833-7252

**China - Xiamen**  
Tel: 86-592-2388138

**China - Zhuhai**  
Tel: 86-756-3210040

### ASIA/PACIFIC

**India - Bangalore**  
Tel: 91-80-3090-4444

**India - New Delhi**  
Tel: 91-11-4160-8631

**India - Pune**  
Tel: 91-20-4121-0141

**Japan - Osaka**  
Tel: 81-6-6152-7160

**Japan - Tokyo**  
Tel: 81-3-6880-3770

**Korea - Daegu**  
Tel: 82-53-744-4301

**Korea - Seoul**  
Tel: 82-2-554-7200

**Malaysia - Kuala Lumpur**  
Tel: 60-3-7651-7906

**Malaysia - Penang**  
Tel: 60-4-227-8870

**Philippines - Manila**  
Tel: 63-2-634-9065

**Singapore**  
Tel: 65-6334-8870

**Taiwan - Hsin Chu**  
Tel: 886-3-577-8366

**Taiwan - Kaohsiung**  
Tel: 886-7-213-7830

**Taiwan - Taipei**  
Tel: 886-2-2508-8600

**Thailand - Bangkok**  
Tel: 66-2-694-1351

**Vietnam - Ho Chi Minh**  
Tel: 84-28-5448-2100

### EUROPE

**Austria - Wels**  
Tel: 43-7242-2244-39  
Fax: 43-7242-2244-393

**Denmark - Copenhagen**  
Tel: 45-4485-5910  
Fax: 45-4485-2829

**Finland - Espoo**  
Tel: 358-9-4520-820

**France - Paris**  
Tel: 33-1-69-53-63-20  
Fax: 33-1-69-30-90-79

**Germany - Garching**  
Tel: 49-8931-9700

**Germany - Haan**  
Tel: 49-2129-3766400

**Germany - Heilbronn**  
Tel: 49-7131-72400

**Germany - Karlsruhe**  
Tel: 49-721-625370

**Germany - Munich**  
Tel: 49-89-627-144-0  
Fax: 49-89-627-144-44

**Germany - Rosenheim**  
Tel: 49-8031-354-560

**Israel - Ra'anana**  
Tel: 972-9-744-7705

**Italy - Milan**  
Tel: 39-0331-742611  
Fax: 39-0331-466781

**Italy - Padova**  
Tel: 39-049-7625286

**Netherlands - Drunen**  
Tel: 31-416-690399  
Fax: 31-416-690340

**Norway - Trondheim**  
Tel: 47-7288-4388

**Poland - Warsaw**  
Tel: 48-22-3325737

**Romania - Bucharest**  
Tel: 40-21-407-87-50

**Spain - Madrid**  
Tel: 34-91-708-08-90  
Fax: 34-91-708-08-91

**Sweden - Gothenberg**  
Tel: 46-31-704-60-40

**Sweden - Stockholm**  
Tel: 46-8-5090-4654

**UK - Wokingham**  
Tel: 44-118-921-5800  
Fax: 44-118-921-5820