

## LMX9838 Bluetooth Serial Port Module

### 1 Features

- Complete Bluetooth® 2.0 Stack Including
  - Baseband and Link Manager
  - Protocols: L2CAP, RFCOMM, SDP
  - Profiles: GAP, SDAP, SPP
- High Integration: Includes Processor, Antenna, Crystal, EEPROM, LDO
- Supporting up to 7 Active Bluetooth Data Links and 1 Active SCO Link
- Class 2 Operation
- UART Command/Data Port Speed 921.6kbits/s
- AAI for External PCM Codec
- Better than -80dBm Input Sensitivity
- FCC, IC, CE, and Japan MIC Certified
- Bluetooth SIG QD ID: B012394
- Compact Size: 10 mm x 17 mm x 2.0 mm

### 2 Applications

- Factory Automation and Control
- Test and Measurement
- Telematics
- POS Terminals
- Medical/Telemedicine
- Data Logging Systems
- Audio Gateways

### 4 Block Diagram

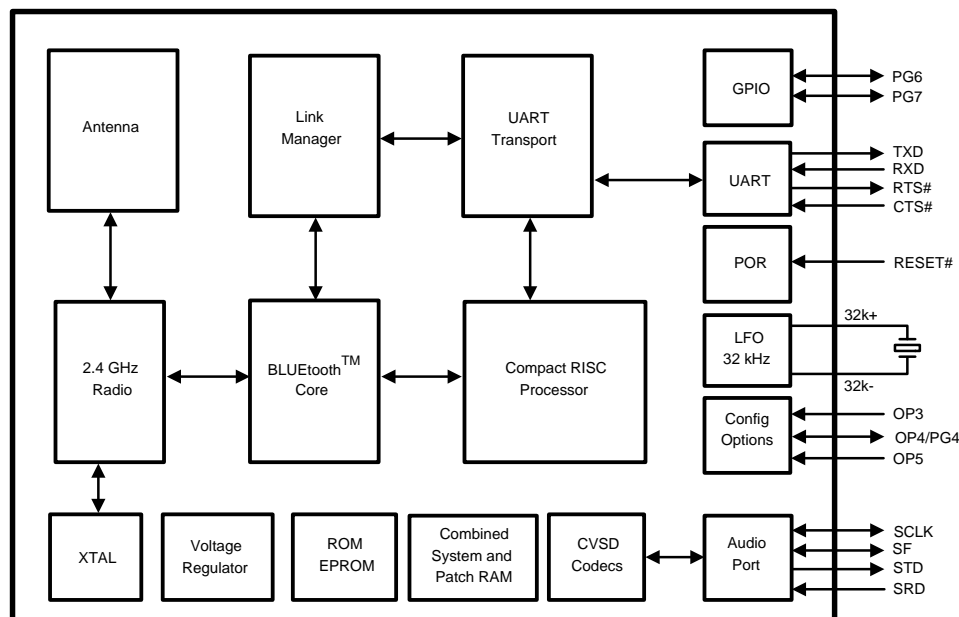

### 3 Description

The Texas Instruments LMX9838 Bluetooth Serial Port module is a fully integrated Bluetooth 2.0 baseband controller, 2.4 GHz radio, crystal, antenna, LDO and discreets; combined to form a complete small form factor (10 mm x 17 mm x 2.0 mm) Bluetooth node.

All hardware and firmware is included to provide a complete solution from antenna through the complete lower and upper layers of the Bluetooth stack, up to the application including the Generic Access Profile (GAP), the Service Discovery Application Profile (SDAP), and the Serial Port Profile (SPP). The module includes a configurable service database to fulfil service requests for additional profiles on the host. Moreover, the LMX9838 is qualified as a Bluetooth endproduct, ready to be used in the end application without additional testing and license cost.

Based on TI's CompactRISC 16-bit processor architecture and Digital Smart Radio technology, the LMX9838 is optimized to handle the data and link management processing requirements of a Bluetooth node.

#### Device Information<sup>(1)</sup>

PART NUMBER	PACKAGE	BODY SIZE (NOM)
LMX9838	PLGA (70)	17.00 mm x 10.00 mm

(1) For all available packages, see the orderable addendum at the end of the data sheet.



## Table of Contents

<b>1 Features</b> ..... 1 <b>2 Applications</b> ..... 1 <b>3 Description</b> ..... 1 <b>4 Block Diagram</b> ..... 1 <b>5 Revision History</b> ..... 2 <b>6 Pin Configuration and Functions</b> ..... 3 <b>7 Specifications</b> ..... 5 7.1 Absolute Maximum Ratings ..... 5 7.2 Handling Ratings ..... 5 7.3 Recommended Operating Conditions ..... 5 7.4 Thermal Information ..... 5 7.5 Power Supply Requirements ..... 6 7.6 Digital DC Characteristics ..... 6 7.7 RF Receiver Performance Characteristics ..... 7 7.8 RF Transmitter Performance Characteristics ..... 7 7.9 RF Synthesizer Performance Characteristics ..... 8 <b>8 Detailed Description</b> ..... 9 8.1 Overview ..... 9 8.2 Functional Block Diagram ..... 9	8.3 Feature Description ..... 9 8.4 Device Functional Modes ..... 17 8.5 Programming - Command Interface ..... 21 <b>9 Application and Implementation</b> ..... 26 9.1 Typical Applications ..... 26 <b>10 Power Supply Recommendations</b> ..... 31 10.1 Power Supply Schematics ..... 31 10.2 Filtered Power Supply ..... 33 10.3 Power Up ..... 33 <b>11 Regulatory Compliance</b> ..... 35 11.1 FCC Instructions ..... 35 <b>12 Device and Documentation Support</b> ..... 38 12.1 Device Support ..... 38 12.2 Documentation Support ..... 38 12.3 Trademarks ..... 38 12.4 Electrostatic Discharge Caution ..... 38 12.5 Glossary ..... 38 <b>13 Mechanical, Packaging, and Orderable Information</b> ..... 38
--	---

## 5 Revision History

NOTE: Page numbers for previous revisions may differ from page numbers in the current version.

<b>Changes from Revision E (January 2014) to Revision F</b>	<b>Page</b>
<ul style="list-style-type: none"> <li>• Added Handling Rating table, Feature Description section, Device Functional Modes, Application and Implementation section, Power Supply Recommendations section, Layout section, Device and Documentation Support section, and Mechanical, Packaging, and Orderable Information section ..... 1</li> <li>• Changed EN 301 489-17 v1.2.1 to EN 301 489-17 v2.2.1 ..... 35</li> </ul>	
<b>Changes from Revision D (April 2013) to Revision E</b>	<b>Page</b>
<ul style="list-style-type: none"> <li>• Added two parameters for operating conditions ..... 5</li> <li>• Changed schematic ..... 28</li> </ul>	
<b>Changes from Revision C (April 2013) to Revision D</b>	<b>Page</b>
<ul style="list-style-type: none"> <li>• Changed layout of National Data Sheet to TI format ..... 36</li> </ul>	

## 6 Pin Configuration and Functions

PLGA NAW0070A Package  
70 Pins  
Top View

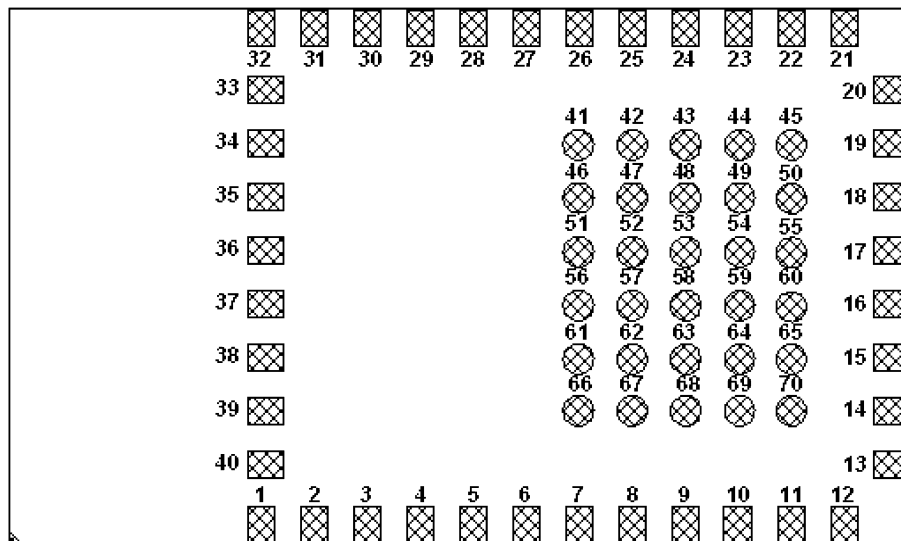

X-ray - Top View

### Pin Functions

PAD NAME	PAD LOCATION	I/O	DEFAULT LAYOUT	DESCRIPTION
<b>SYSTEM INTERFACE SIGNALS</b>				
OP3	16	I		<b>OP3:</b> Pin checked during Startup Sequence for configuration option
OP4/PG4	26	OP4: I PG4: I/O		<b>OP4:</b> Pin checked during Startup Sequence for configuration option <b>PG4:</b> GPIO
OP5	25	I/O		<b>OP5:</b> Pin checked during Startup Sequence for configuration option
32K-	28	O	NC (if not used)	32.768 kHz Crystal Oscillator
32K+	27	I	GND (if not used)	32.768 kHz Crystal Oscillator
<b>UART Interface Signals</b>				
CTS# <sup>(1)</sup>	15	I	GND (if not used)	Host Serial Port Clear To Send (active low)
RTS# <sup>(2)</sup>	14	O	NC (if not used)	Host Serial Port Request To Send (active low)
RXD	12	I		Host Serial Port Receive Data
TXD	13	O		Host Serial Port Transmit Data
<b>AUXILIARY PORTS INTERFACE SIGNALS</b>				
PG6	7	I/O		GPIO - Default setup LINK STATUS indication
PG7	19	I/O		GPIO - Default setup RF traffic LED indication
RESET#	2	I	Low active, either NC or connect to host	Module Reset (active low)
XOSCEN	8	O		Host main Clock Request. Toggles with Main crystal (X1) enable/disable
<b>AUDIO INTERFACE SIGNALS</b>				
SCLK	20	I/O		Audio PCM Interface Clock
SFS	21	I/O		Audio PCM Interface Frame Synchronization
SRD	23	I		Audio PCM Interface Receive Data Input
STD	22	O		Audio PCM Interface Transmit Data Output

(1) Connect to GND if CTS is not use.

(2) Treat As No Connect If RTS is not used. Pad required for mechanical stability.

**Pin Functions (continued)**

PAD NAME	PAD LOCATION	I/O	DEFAULT LAYOUT	DESCRIPTION
<b>POWER, GROUND AND NO CONNECT SIGNALS</b>				
GND	3, 4, 17, 18, 24, 29, 30, 31, 32	I	GND	Must be connected to ground plane
MV <sub>CC</sub>	6	I		Module internal Voltage Regulator Input
NC	1, 5, 33, 34, 35, 36, 37, 38, 39, 40		NC	Place Pads for stability.
NC	41, 42, 43, 44, 45, 46, 47, 48, 49, 50, 51, 52, 53, 54, 55, 56, 57, 58, 59, 60, 61, 62, 63, 64, 65, 66, 67, 68, 69, 70		NC	DO NOT PLACE ANY PADS.
V <sub>CC_CORE</sub>	9	I/O		Voltage Regulator Input/Output
V <sub>CC</sub>	10	I		Voltage Regulator Input Baseband
V <sub>CC_IO</sub>	11	I		Power Supply I/O

## 7 Specifications

### 7.1 Absolute Maximum Ratings<sup>(1)</sup>

The following conditions are true unless otherwise stated in the tables:  $T_A = -40^{\circ}\text{C}$  to  $+85^{\circ}\text{C}$ .  $V_{CC} = 3.3\text{ V}$ . RF system performance specifications are ensured on Texas Instruments Flagstaff board rev 2.1 evaluation platform.

		MIN	MAX	UNIT
$V_{CC}$	Digital Voltage Regulator input	-0.2	4	V
$V_I$	Voltage on any pad with GND = 0 V	-0.2	$V_{CC} + 0.2$	V
$T_{LNOPB}$	Lead Temperature NOPB <sup>(2)(3)</sup> (solder 40 sec.)		250	$^{\circ}\text{C}$

- (1) Absolute Maximum Ratings indicate limits beyond which damage to the device may occur. Operating Ratings indicate conditions for which the device is intended to be functional. This device is a high performance RF integrated circuit and is ESD sensitive. Handling and assembly of this device should be performed at ESD free workstations.
- (2) Reference IPC/JDEC J-STD-20C spec.
- (3) NOPB = No Pb (No Lead).

### 7.2 Handling Ratings

		MIN	MAX	UNIT
$T_{stg}$	Storage temperature range	-65	150	$^{\circ}\text{C}$
$V_{(ESD)}$	Electrostatic discharge	Human body model (HBM), per ANSI/ESDA/JEDEC JS-001, all pins <sup>(1)</sup>	2000	V
		Charged device model (CDM), per JEDEC specification JESD22-C101, all pins <sup>(2)</sup>	1000	
$ESD_{MM}$	ESD - Machine Model		200 <sup>(3)</sup>	V

- (1) JEDEC document JEP155 states that 500-V HBM allows safe manufacturing with a standard ESD control process.
- (2) JEDEC document JEP157 states that 250-V CDM allows safe manufacturing with a standard ESD control process.
- (3) All pins meet 200V Machine Model ESD rating except pins RXD, TXD, CTS, RTS, PG4, OP5, PG6, PG7, SCL, SDA, MDOD1, MWCS, SFS, STD, SRD RATED AT 150v.

### 7.3 Recommended Operating Conditions

		MIN	NOM	MAX	UNIT
$MV_{CC}$	Module internal Voltage Regulator input	3.0	3.3	3.6	V
$V_{CC}$	Digital Voltage Regulator input	2.5	3.3	3.6	V
$T_R$	Digital Voltage Regulator Rise Time			10	$\mu\text{s}$
$T_A$	Ambient Operating Temperature Range Fully Functional Bluetooth Node	-40	+25	+85	$^{\circ}\text{C}$
$V_{CC\_IO}$ <sup>(1)</sup>	Supply Voltage Digital I/O	1.8	3.3	3.6	V
$V_{CC\_CORE}$	Supply Voltage Output <sup>(2)</sup>		1.8		V
$V_{CC\_CORE\_MAX}$	Supply Voltage Output Max Load		5		mA
$V_{CC\_CORE\_SHORT}$	When used as Supply Input ( $V_{CC}$ grounded)	1.6	1.8	2	V

- (1)  $V_{CC}$  must be  $> (V_{CC\_IO} - 0.5\text{V})$  to avoid backdrive supply.
- (2) Should not be used for external supplies

### 7.4 Thermal Information

THERMAL METRIC <sup>(1)</sup>	LMX9838	UNIT	
	NAW		
	70 PINS		
$R_{\theta JA}$	Junction-to-ambient thermal resistance	45	$^{\circ}\text{C}/\text{W}$

- (1) For more information about traditional and new thermal metrics, see the *IC Package Thermal Metrics* application report, [SPRA953](#).

## 7.5 Power Supply Requirements<sup>(1)(2)</sup>

PARAMETER		MIN	TYP <sup>(3)</sup>	MAX	UNIT
I <sub>CC-TX</sub>	Power supply current for continuous transmit			65	mA
I <sub>CC-RX</sub>	Power supply current for continuous receive			65	mA
I <sub>RXSL</sub>	Receive Data in SPP Link, Slave		26		mA
I <sub>RXM</sub>	Receive Data in SPP Link, Master		23		mA
I <sub>SnM</sub>	Sniff Mode, Sniff interval 1 second		6.5		mA
I <sub>SC-TLDIS</sub>	Scanning, No Active Link, TL Disabled		1.1		mA

(1) Power supply requirements based on Class II output power.

(2) Based on UART Baudrate 115.2kbit/s.

(3) V<sub>CC</sub> = 3.3 V, Ambient Temperature = +25 °C.

## 7.6 Digital DC Characteristics

PARAMETER		TEST CONDITIONS	MIN	MAX	UNIT
V <sub>IH</sub>	Logical 1 Input Voltage high (except oscillator I/O)	1.8 V ≤ V <sub>CC-IO</sub> ≤ 3.0 V 3.0 V ≤ V <sub>CC-IO</sub> ≤ 3.6 V	0.7 × V <sub>CC-IO</sub> 2.0	V <sub>CC-IO</sub> + 0.2 V <sub>CC-IO</sub> + 0.2	V
V <sub>IL</sub>	Logical 0 Input Voltage low (except oscillator I/O)	1.8 V ≤ V <sub>CC-IO</sub> ≤ 3.0 V 3.0 V ≤ V <sub>CC-IO</sub> ≤ 3.6 V	-0.2 -0.2	0.25 × V <sub>CC-IO</sub> 0.8	V
V <sub>OH</sub>	Logical 1 Output Voltage high (except oscillator I/O)	V <sub>CC-IO</sub> = 1.8 V V <sub>CC-IO</sub> = 3.0 V	0.7 × V <sub>CC-IO</sub> 2.4		V
V <sub>OL</sub>	Logical 0 Output Voltage low (except oscillator I/O)			0.4	V
V <sub>HYS</sub>	Hysteresis Loop Width <sup>(1)</sup>		0.1 × V <sub>CC</sub>		V
I <sub>IH</sub>	Logical 1 Input leakage High			10	μA
I <sub>IL</sub>	Logical 0 Input leakage Low			-10	μA
I <sub>OH</sub>	Logical 1 Output Current	V <sub>OH</sub> = 2.4 V, V <sub>CC-IO</sub> = 3.0 V	-10		mA
I <sub>OL</sub>	Logical 0 Output Current	V <sub>OH</sub> = 0.4 V, V <sub>CC-IO</sub> = 3.0 V	10		mA

(1) Specified by design.

## 7.7 RF Receiver Performance Characteristics

All tests performed are based on Bluetooth Test Specification revision 2.0. All tests are measured at antenna port unless otherwise specified.  $T_A = -40^\circ\text{C}$  to  $+85^\circ\text{C}$  --  $V_{DD\_RF} = 2.8\text{ V}$  unless otherwise specified. RF system performance specifications are ensured on Texas Instruments Flagstaff board rev 2.1 evaluation platform. All RF parameters are tested prior to the antenna.

PARAMETER		TEST CONDITIONS	MIN	TYP <sup>(1)</sup>	MAX	UNIT
RX <sub>sense</sub>	Receive Sensitivity	BER < 0.001	2.402 GHz	-80	-76	dBm
			2.441 GHz	-80	-76	dBm
			2.480 GHz	-80	-76	dBm
PinRF	Maximum Input Level		-10	0		dBm
IMP <sup>(2)</sup>	Intermodulation Performance	F <sub>1</sub> = + 3 MHz, F <sub>2</sub> = + 6 MHz, P <sub>inRF</sub> = -64 dBm	-38	-36		dBm
RSSI	RSSI Dynamic Range at LNA Input		-72		-52	dBm
OOB <sup>(2)</sup>	Out Of Band Blocking Performance	P <sub>inRF</sub> = -10 dBm, 30 MHz < F <sub>CWI</sub> < 2 GHz, BER < 0.001	-10			dBm
		P <sub>inRF</sub> = -27 dBm, 2000 MHz < F <sub>CWI</sub> < 2399 MHz, BER < 0.001	-27			dBm
		P <sub>inRF</sub> = -27 dBm, 2498 MHz < F <sub>CWI</sub> < 3000 MHz, BER < 0.001	-27			dBm
		P <sub>inRF</sub> = -10 dBm, 3000 MHz < F <sub>CWI</sub> < 12.75 GHz, BER < 0.001	-10			dBm

(1) Typical operating conditions are at 2.75V operating voltage and 25°C ambient temperature.

(2) The  $f_0 = -64\text{ dBm}$  Bluetooth modulated signal,  $f_1 = -39\text{ dBm}$  sine wave,  $f_2 = -39\text{ dBm}$  Bluetooth modulated signal,  $f_0 = 2f_1 - f_2$ , and  $|f_2 - f_1| = n * 1\text{ MHz}$ , where n is 3, 4, or 5. For the typical case, n = 3.

## 7.8 RF Transmitter Performance Characteristics

All tests performed are based on Bluetooth Test Specification revision 2.0. All tests are measured at antenna port unless otherwise specified.  $T_A = -40^\circ\text{C}$  to  $+85^\circ\text{C}$  --  $V_{DD\_RF} = 2.8\text{ V}$  unless otherwise specified. RF system performance specifications are ensured on Texas Instruments Flagstaff board rev 2.1 evaluation platform. All RF parameters are tested prior to the antenna.

PARAMETER		TEST CONDITIONS	MIN	TYP <sup>(1)</sup>	MAX	UNIT
P <sub>OUTRF</sub>	Transmit Output Power	2.402 GHz	-4	0	+3	dBm
		2.441 GHz	-4	0	+3	dBm
		2.480 GHz	-4	0	+3	dBm
MOD $\Delta f_{1\text{AVG}}$	Modulation Characteristics	Data = 00001111	140	165	175	kHz
MOD $\Delta f_{2\text{MAX}}$ <sup>(2)</sup>	Modulation Characteristics	Data = 10101010	115	125		kHz
$\Delta f_{2\text{AVG}}/\Delta f_{1\text{AVG}}$ <sup>(3)</sup>	Modulation Characteristics		0.8			
20 dB Bandwidth					1000	kHz
P <sub>OUT</sub> 2*f <sub>0</sub> <sup>(4)</sup>	PA 2 <sup>nd</sup> Harmonic Suppression	Maximum gain setting: f <sub>0</sub> = 2402 MHz, P <sub>out</sub> = 4804 MHz			-30	dBm
Z <sub>RFOUT</sub> <sup>(5)</sup>	RF Output Impedance/Input Impedance of RF Port (RF_inout)	P <sub>out</sub> @ 2.5 GHz		47		Ω

(1) Typical operating conditions are at 2.75V operating voltage and 25°C ambient temperature.

(2)  $\Delta f_{2\text{max}} \geq 115\text{ kHz}$  for at least 99.9% of all  $\Delta f_{2\text{max}}$ .

(3) Modulation index set between 0.28 and 0.35.

(4) Out-of-Band spurs only exist at 2nd and 3rd harmonics of the CW frequency for each channel.

(5) Not tested in production.

## 7.9 RF Synthesizer Performance Characteristics

All tests performed are based on Bluetooth Test Specification revision 2.0. All tests are measured at antenna port unless otherwise specified.  $T_A = -40^{\circ}\text{C}$  to  $+85^{\circ}\text{C}$ .  $V_{DD\_RF} = 2.8\text{V}$  unless otherwise specified. RF system performance specifications are ensured on Texas Instruments Flagstaff board rev 2.1 evaluation platform. All RF parameters are tested prior to the antenna.

	PARAMETER	TEST CONDITIONS	MIN	TYP	MAX	UNIT		
	$f_{VCO}$	VCO Frequency Range	2402		2480	MHz		
	$t_{LOCK}$	Lock Time	$f_0 \pm 20\text{ kHz}$		120	$\mu\text{s}$		
	$\Delta f_{0\text{offset}}^{(1)}$	Initial Carrier Frequency Tolerance	During preamble		-75	0	75	kHz
	$\Delta f_{0\text{drift}}^{(1)}$	Initial Carrier Frequency Drift	DH1 data packet		-25	0	25	kHz
			DH3 data packet		-40	0	40	kHz
			DH5 data packet		-40	0	40	kHz
			Drift Rate		-20	0	20	kHz/50 $\mu\text{s}$
	$t_D - \text{Tx}$	Transmitter Delay Time	From Tx data to antenna		4	$\mu\text{s}$		

- (1) Frequency accuracy is dependent on crystal oscillator chosen. The crystal must have a cumulative accuracy of  $< \pm 20\text{ppm}$  to meet Bluetooth specifications.



## 8 Detailed Description

### 8.1 Overview

LMX9838 is a fully certified Bluetooth 2.0 module, with integrated processor, radio, antenna, LDO, crystal, and passive components to form a small form factor plug-n-play solution. The built-in Bluetooth stacks up to the application layer allows users to communicate directly with SPP commands, and develop additional SPP-based Bluetooth profiles on Host through UART interface.

### 8.2 Functional Block Diagram

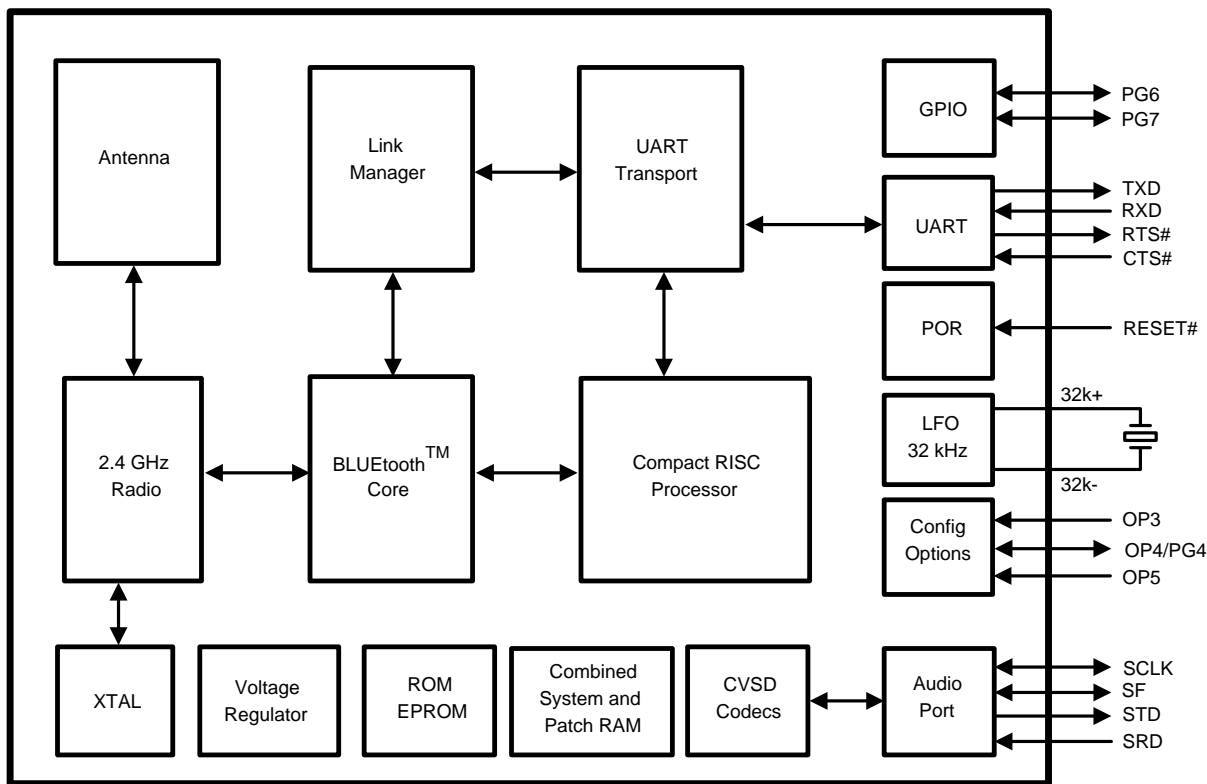

### 8.3 Feature Description

#### 8.3.1 Features Overview

The firmware supplied in the on-chip ROM memory offers a complete Bluetooth (v2.0) stack including profiles and command interface. This firmware features point-to-point and point-to-multipoint link management supporting data rates up to the theoretical maximum over RFCOMM of 704 kbps. The internal memory supports up to 7 active Bluetooth data links and one active SCO link.

The on-chip Patch RAM provided for lowest cost and risk, allows the flexibility of firmware upgrade.

The module is lead free and RoHS (Restriction of Hazardous Substances) compliant.

For more information on those quality standards, please visit our green compliance website at <http://focus.ti.com/quality/docs/qualityhome.tsp>.

## Feature Description (continued)

### 8.3.2 Hardware

- Baseband and Link Management Processors based on TI's CompactRISC Core
- Embedded ROM and Patch RAM Memory
- Auxiliary Host Interface Ports:
  - Link Status
  - Transceiver Status (Tx or Rx)
- Advanced Power Management (APM) Features
- Supports Low-Power Mode with Optional 32.768 kHz Oscillator
- Full Radio Path Integrated Including Antenna
- On-Chip Reference Crystal for Bluetooth Operation
- Single Supply Voltage

### 8.3.3 Firmware

- Additional Profile Support on Host. e.g:
  - Dial Up Networking (DUN)
  - Facsimile Profile (FAX)
  - File Transfer Protocol (FTP)
  - Object Push Profile (OPP)
  - Synchronization Profile (SYNC)
  - Headset (HSP)
  - Handsfree Profile (HFP)
  - Basic Imaging Profile (BIP)
  - Basic Printing Profile (BPP)
- On-Chip Application Including:
  - Default Connections
  - Command Interface:
    - Link Setup and Configuration (also Multipoint)
    - Configuration of the Module
    - Service Database Modifications
  - UART Transparent Mode
  - Optimized Cable Replacement:
    - Automatic Transparent Mode
    - Event Filter

### 8.3.4 Compliance

- FCC compliance: The device complies with Part 15 of FCC Rules. Operation is subject to the following two conditions:
  - This device may not cause harmful interference
  - This device must accept any interference received, including interference that may cause undesired operation
- Compliant with IC for Canada, CE for Europe, and MIC for Japan. See [Regulatory Compliance](#).

### 8.3.5 Package

- Complete system interface provided in Lead Grid Array on underside for surface mount assembly

## Feature Description (continued)

### 8.3.6 Baseband and Link Management Processors

Baseband and Lower Link control functions are implemented using a combination of Texas Instruments' CompactRISC 16-bit processor and the Bluetooth Lower Link Controller. These processors operate from integrated ROM memory and RAM and execute on-board firmware implementing all Bluetooth functions.

### 8.3.7 Bluetooth Lower Link Controller

The integrated Bluetooth Lower Link Controller (LLC) complies with the Bluetooth Specification version 2.0 and implements the following functions:

- Adaptive Frequency Hopping
- Interlaced Scanning
- Fast Connect
- Support for 1, 3, and 5 slot packet types
- 79 Channel hop frequency generation circuitry
- Fast frequency hopping at 1600 hops per second
- Power management control
- Access code correlation and slot timing recovery

### 8.3.8 Bluetooth Upper Layer Stack

The integrated upper layer stack is prequalified and includes the following protocol layers:

- L2CAP
- RFComm
- SDP

### 8.3.9 Profile Support

The on-chip application of the LMX9838 allows full stand-alone operation, without any Bluetooth protocol layer necessary outside the module. It supports the Generic Access Profile (GAP), the Service Discovery Application Profile (SDAP), and the Serial Port Profile (SPP).

The on-chip profiles can be used as interfaces to additional profiles executed on the host. The LMX9838 includes a configurable service database to answer requests with the profiles supported.

### 8.3.10 Application With Command Interface

The module supports automatic slave operation eliminating the need for an external control unit. The implemented transparent option enables the chip to handle incoming data raw, without the need for packaging in a special format. The device uses a pin to block unallowed connections. This pincode can be fixed or dynamically set.

Acting as master, the application offers a simple but versatile command interface for standard Bluetooth operation like inquiry, service discovery, or serial port connection. The firmware supports up to seven slaves. Default Link Policy settings and a specific master mode allow optimized configuration for the application specific requirements. See the [Integrated Firmware](#) section.

### 8.3.11 Memory

The LMX9838 introduces 16 kB of combined system and Patch RAM memory that can be used for data and/or code upgrades of the ROM based firmware. Due to the flexible startup used for the LMX9838 operating parameters like the Bluetooth Device Address (BD\_ADDR) are defined during boot time. This allows reading out the parameters of an internal EEPROM or programming them directly over UART.

## Feature Description (continued)

### 8.3.12 Transport Port - UART

The LMX9838 provides one Universal Asynchronous Receiver Transmitter (UART). The UART interface consists out of Receive (RX), Transmit (TX), Ready-to-Send (RTS) and Clear-to-Send signals. RTS and CTS are used for hardware handshaking between the host and the LMX9838. Since the LMX9838 acts as gateway between the bluetooth and the UART interface, Texas Instruments recommends to use the handshaking signals especially for transparent operation. In case two signals are used CTS needs to be pulled to GND. Refer to *LMX9838 Software User's Guide*, literature number [SNOA498](#) for detailed information on 2-wire operation.

The UART interface supports formats of 8-bit data with or without parity, with one or two stop bits. It can operate at standard baud rates from 2400bits/s up to a maximum baud rate of 921.6kbits/s. DMA transfers are supported to allow for fast processor independent receive and transmit operation.

The UART baudrate is configured during startup by checking option pins OP3, OP4 and OP5. [Table 2](#) gives the correspondence between the OP pins settings and the UART speed.

The UART offers wakeup from the power save modes via the multi-input wakeup module. When the LMX9838 is in low power mode, RTS# and CTS# can function as Host\_WakeUp and Bluetooth\_WakeUp respectively. [Table 1](#) represents the operational modes supported by the firmware for implementing the transport via the UART.

**Table 1. UART Operation Modes**

ITEM	RANGE	DEFAULT at POWER-UP
Baud Rate	2.4 to 921.6 kbits/s	Either configured by option pins, NVS
Flow Control	RTS#/CTS# or None	RTS#/CTS#
Parity	Odd, Even, None	None
Stop Bits	1,2	1
Data Bits	8	8

OP3, OP4, OP5 can be strapped to the host logic 0 and 1 levels to set the host interface boot-up configuration. Alternatively all OP3, OP4, OP5 can be hardwired over 1k Ohm pullup/pulldown resistors. See [Table 2](#).

**Table 2. UART Frequency Settings**

OP3 <sup>(1)</sup>	OP4 <sup>(2)</sup>	OP5 <sup>(3)</sup>	FUNCTION
1	0	0	UART speed read from NVS
1	0	1	UART speed 9.6 kbps
1	1	0	UART speed 115.2 kbps
1	1	1	UART speed 921.6 kbps

(1) If OP3 is 1, must use 1K pull up

(2) If OP4 is 1, must use 1K pull up

(3) If OP5 is 1, must use 1K pull up

### 8.3.13 Audio Port

#### 8.3.13.1 Advanced Audio Interface

The Advanced Audio Interface (AAI) is an advanced version of the Synchronous Serial Interface (SSI) that provides a full-duplex communications port to a variety of industry-standard 13/14/15/16-bit linear or 8-bit log PCM codecs, DSPs, and other serial audio devices.

The interface allows the support one codec or interface. The firmware selects the desired audio path and interface configuration by a parameter that is located in RAM (imported from non-volatile storage or programmed during boot-up). The audio path options include the OKI MSM7717 codec, the Winbond W681360/W681310 codecs and the PCM slave through the AAI.

In case an external codec or DSP is used the LMX9838 audio interface generates the necessary bit and frame clock driving the interface.

[Table 3](#) summarizes the audio path selection and the configuration of the audio interface at the specific modes.

The LMX9838 supports one SCO link.

**Table 3. Audio Path Configuration**

AUDIO SETTING	INTERFACE	FORMAT	AAI BIT CLOCK	AAI FRAME CLOCK	AAI FRAME SYNC PULSE LENGTH
<b>OKI MSM7717</b>	Advanced audio interface	8-bit log PCM (a-law only)	520 kHz	8 kHz	14 Bits
<b>Winbond W681310</b>	Advanced audio interface	8-bit log PCM A-law and u-law	520 kHz	8 kHz	14 Bits
<b>Winbond W681360</b>	Advanced audio interface	13-bit linear	520 kHz	8 kHz	13 Bits
<b>PCM slave<sup>(1)</sup></b>	Advanced audio interface	8/16 bits	128 - 1024 kHz	8 kHz	8/16 Bits

(1) In PCM slave mode, parameters are stored in NVS. Bit clock and frame clock must be generated by the host interface.

##### 8.3.13.1.1 PCM Slave Configuration Example

PCM slave uses the slot 0, 1 slot per frame, 16 bit linear mode, long frame sync, normal frame sync. In this case, 0x03E0 should be stored in NVS. See *LMX9838 Software User's Guide*, literature number [SNOA498](#) for more details.

### 8.3.14 Auxiliary Ports

#### 8.3.14.1 RESET#

The RESET# is active low and will put radio and baseband into reset.

### 8.3.15 Digital Smart Radio

#### 8.3.15.1 General Purpose I/Os

The LMX9838 device offers 3 pins which either can be used as indication and configuration pins or can be used for General Purpose functionality. The selection is made out of settings derived out of the power up sequence.

In General Purpose configuration the pins are controlled hardware specific commands giving the ability to set the direction, set them to high or low or enable a weak pull-up.

In alternate function the pins have pre-defined indication functionality. Please see [Table 4](#) for a description on the alternate indication functionality.

**Table 4. Alternate GPIO Pin Configuration**

PIN	DESCRIPTION
OP4/PG4	Operation Mode pin to configure Transport Layer settings during boot-up
PG6	GPIO - Link Status indication
PG7	RF Traffic indication

### 8.3.16 Functional Architecture

The integrated Digital Smart Radio utilizes a heterodyne receiver architecture with a low intermediate frequency (2 MHz) such that the intermediate frequency filters can be integrated on chip. The receiver consists of a low-noise amplifier (LNA) followed by two mixers. The intermediate frequency signal processing blocks consist of a poly-phase bandpass filter (BPF), two hard-limiters (LIM), a frequency discriminator (DET), and a post-detection filter (PDF). The received signal level is detected by a received signal strength indicator (RSSI).

The received frequency equals the local oscillator frequency (fLO) plus the intermediate frequency (fIF):

$$f_{RF} = f_{LO} + f_{IF} \text{ (supradyn)}$$

The radio includes a synthesizer consisting of a phase detector, a charge pump, an (off-chip) loop-filter, an RF-frequency divider, and a voltage controlled oscillator (VCO).

The transmitter utilizes IQ-modulation with bit-stream data that is gaussian filtered. Other blocks included in the transmitter are a VCO buffer and a power amplifier (PA).

### 8.3.17 Receiver Front-End

The receiver front-end consists of a low-noise amplifier (LNA) followed by two mixers and two low-pass filters for the I- and Q-channels.

The intermediate frequency (IF) part of the receiver front-end consists of two IF amplifiers that receive input signals from the mixers, delivering balanced I- and Q-signals to the poly-phase bandpass filter. The poly-phase bandpass filter is directly followed by two hard-limiters that together generate an AD-converted RSSI signal.

### 8.3.18 Poly-Phase Bandpass Filter

The purpose of the IF bandpass filter is to reject noise and spurious (mainly adjacent channel) interference that would otherwise enter the hard limiting stage. In addition, it takes care of the image rejection.

The bandpass filter uses both the I- and Q-signals from the mixers. The out-of-band suppression should be higher than 40 dB ( $f < 1$  MHz,  $f > 3$  MHz). The bandpass filter is tuned over process spread and temperature variations by the autotuner circuitry. A 5th order Butterworth filter is used.

### 8.3.19 Hard-Limiter and RSSI

The I- and Q-outputs of the bandpass filter are each followed by a hard-limiter. The hard-limiter has its own reference current. The RSSI (Received Signal Strength Indicator) measures the level of the RF input signal.

The RSSI is generated by piece-wise linear approximation of the level of the RF signal. The RSSI has a mV/dB scale, and an analog-to-digital converter for processing by the baseband circuit. The input RF power is converted to a 5-bit value. The RSSI value is then proportional to the input power (in dBm).

The digital output from the ADC is sampled on the BPKTCTL signal low-to-high transition.

### 8.3.20 Receiver Back-End

The hard-limiters are followed by a two frequency discriminators. The I-frequency discriminator uses the 90° phase-shifted signal from the Q-path, while the Q-discriminator uses the 90° phase-shifted signal from the I-path. A poly-phase bandpass filter performs the required phase shifting. The output signals of the I- and Q-discriminator are subtracted and filtered by a low-pass filter. An equalizer is added to improve the eye-pattern for 101010 patterns.

After equalization, a dynamic AFC (automatic frequency offset compensation) circuit and slicer extract the RX\_DATA from the analog data pattern. It is expected that the Eb/No of the demodulator is approximately 17 dB.

### 8.3.21 Frequency Discriminator

The frequency discriminator gets its input signals from the limiter. A defined signal level (independent of the power supply voltage) is needed to obtain the input signal. Both inputs of the frequency discriminator have limiting circuits to optimize performance. The bandpass filter in the frequency discriminator is tuned by the autotuning circuitry.

### 8.3.22 Post-Detection Filter and Equalizer

The output signals of the FM discriminator first go through a post-detection filter and then through an equalizer. Both the post-detection filter and equalizer are tuned to the proper frequency by the autotuning circuitry. The post-detection filter is a low-pass filter intended to suppress all remaining spurious signals, such as the second harmonic (4 MHz) from the FM detector and noise generated after the limiter.

The post-detection filter also helps for attenuating the first adjacent channel signal. The equalizer improves the eye-opening for 101010 patterns. The post-detection filter is a third order Butterworth filter.

### 8.3.23 Autotuning Circuitry

The autotuning circuitry is used for tuning the bandpass filter, the detector, the post-detection filter, the equalizer, and the transmit filters for process and temperature variations. The circuit also includes an offset compensation for the FM detector.

### 8.3.24 Synthesizer

The synthesizer consists of a phase-frequency detector, a charge pump, a low-pass loop filter, a programmable frequency divider, a voltage-controlled oscillator (VCO), a delta-sigma modulator, and a lookup table.

The frequency divider consists of a divide-by-2 circuit (divides the 5 GHz signal from the VCO down to 2.5 GHz), a divide-by-8-or-9 divider, and a digital modulus control. The delta-sigma modulator controls the division ratio and also generates an input channel value to the lookup table.

### 8.3.25 Phase-Frequency Detector

The phase-frequency detector is a 5-state phase-detector. It responds only to transitions, hence phase-error is independent of input waveform duty cycle or amplitude variations. Loop lockup occurs when all the negative transitions on the inputs, F\_REF and F\_MOD, coincide. Both outputs (i.e., Up and Down) then remain high. This is equal to the zero error mode. The phase-frequency detector input frequency range operates at 12 MHz.

### 8.3.26 Transmitter Circuitry

The transmitter consists of ROM tables, two Digital to Analog (DA) converters, two low-pass filters, IQ mixers, and a power amplifier (PA).

The ROM tables generate a digital IQ signal based on the transmit data. The output of the ROM tables is inserted into IQ-DA converters and filtered through two low-pass filters. The two signal components are mixed up to 2.5 GHz by the TX mixers and added together before being inserted into the transmit PA.

### 8.3.27 IQ-DA Converters and TX Mixers

The ROM output signals drive an I- and a Q-DA converter. Two Butterworth low-pass filters filter the DA output signals. The 6 MHz clock for the DA converters and the logic circuitry around the ROM tables are derived from the autotuner.

The TX mixers mix the balanced I- and Q-signals up to 2.4-2.5 GHz. The output signals of the I- and Q-mixers are summed.

### 8.3.28 32 kHz Oscillator

An oscillator is provided (see [Figure 1](#)) that is tuned to provide optimum performance and low-power consumption while operating with a 32.768 kHz crystal. An external crystal clock network is required between the 32k+ clock input (pad 27) and the 32k- clock output (pad 28) signals. The oscillator is built in a Pierce configuration and uses two external capacitors. [Table 5](#) provides the oscillator's specifications.

In case the 32kHz is not used, it is recommended to leave 32k- open and connect 32k+ to GND.

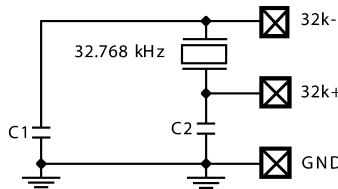

Figure 1. 32.768 kHz Oscillator

Table 5. 32.768 kHz Oscillator Specifications

PARAMETER		CONDITION	MIN	TYP	MAX	UNIT
V <sub>DD</sub>	Supply Voltage		1.62	1.8	1.98	V
I <sub>DDACT</sub>	Supply Current (Active)			2		μA
f	Nominal Output Frequency			32.768		kHz
V <sub>PPOSC</sub>	Oscillating Amplitude			1.8		V
	Duty Cycle		40%	—	60%	

### 8.3.29 Integrated Firmware

The LMX9838 device includes the full Bluetooth stack up to RFCOMM to support the following profiles:

- GAP (Generic Access Profile)
- SDAP (Service Discovery Application Profile)
- SPP (Serial Port Profile)

[Figure 2](#) shows the Bluetooth protocol stack with command interpreter interface. The command interpreter offers a number of different commands to support the functionality given by the different profiles. Execution and interface timing is handled by the control application.

The chip has an internal data area in RAM that includes the parameters shown in [Table 6](#).



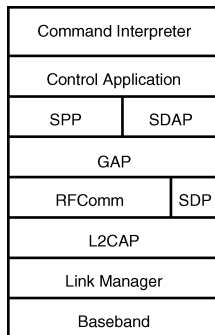

**Figure 2. LMX9838 Software Implementation**

## 8.4 Device Functional Modes

### 8.4.1 Operation Modes

On boot-up, the application configures the module following the parameters in the data area.

#### 8.4.1.1 Automatic Operation

##### 8.4.1.1.1 No Default Connections Stored:

In Automatic Operation the module is connectable and discoverable and automatically answers to service requests. The command interpreter listens to commands and links can be set up. The full command list is supported.

If connected by another device, the module sends an event back to the host, where the RFCOMM port has been connected, and switches to transparent mode.

##### 8.4.1.1.2 Default Connections Stored

If default connections were stored on a previous session, once the LMX9838 is reset, it will attempt to connect each device stored within the data RAM three times. The host will be notified about the success of the link setup via a link status event.

##### 8.4.1.1.3 Non-Automatic Operation

In Non-Automatic Operation, the LMX9838 does not check the default connections section within the Data RAM. If connected by another device, it will NOT switch to transparent mode and continue to interpret data sent on the UART.

##### 8.4.1.1.4 Transparent Mode

The LMX9838 supports transparent data communication from the UART interface to a bluetooth link.

If activated, the module does not interpret the commands on the UART which normally are used to configure and control the module. The packages don't need to be formatted as described in [Table 8](#). Instead all data are directly passed through the firmware to the active bluetooth link and the remote device.

Transparent mode can only be supported on a point-to-point connection. To leave Transparent mode, the host must send a UART\_BREAK signal to the module.

## Device Functional Modes (continued)

### 8.4.1.1.5 Force Master Mode

In Force Master mode tries to act like an access point for multiple connections. For this it will only accept the link if a Master/slave role switch is accepted by the connecting device. After successful link establishment the LMX9838 will be Master and available for additional incoming links. On the first incoming link the LMX9838 will switch to transparent depending on the setting for automatic or command mode. Additional links will only be possible if the device is not in transparent mode.

### 8.4.2 Default Connections

The LMX9838 device supports the storage of up to 3 devices within its NVS. Those connections can either be connected after reset or on demand using a specific command.

### 8.4.3 Event Filter

The LMX9838 uses events or indicators to notify the host about successful commands or changes at the bluetooth interface. Depending on the application the LMX9838 can be configured. The following levels are defined:

- No Events:
  - The LMX9838 is not reporting any events. Optimized for passive cable replacement solutions.
- Standard LMX9838 events:
  - Only necessary events will be reported.
- All events:
  - Additional to the standard all changes at the physical layer will be reported.

### 8.4.4 Default Link Policy

Each Bluetooth Link can be configured to support M/S role switch, Hold Mode, Sniff Mode and Park Mode. The default link policy defines the standard setting for incoming and outgoing connections.

### 8.4.5 Audio Support

The LMX9838 offers commands to establish and release synchronous connections (SCO) to support Headset or Handsfree applications. The firmware supports one active link with all available package types (HV1, HV2, HV3), routing the audio data between the bluetooth link and the advanced audio interface. In order to provide the analog data interface, an external audio codec is required. The LMX9838 includes a list of codecs which can be used.

**Table 6. Operation Parameters Stored in LMX9838**

PARAMETER	DEFAULT VALUE	DESCRIPTION
BDADDR	Preprogrammed by TI	Bluetooth device address
Local Name	Serial port device	
PinCode	0000	Bluetooth PinCode
Operation Mode	Automatic ON	Automatic mode ON or OFF
Default Connections	0	Up to seven default devices to connect to
SDP Database	1 SPP entry: Name: COM1 Authentication and encryption enabled	Service discovery database, control for supported profiles
UART Speed	9600	Sets the speed of the physical UART interface to the host
UART Settings	1 Stop bit, parity disabled	Parity and stop bits on the hardware UART interface
Ports to Open	0000 0001	Defines the RFComm ports to open
Link Keys	No link keys	Link keys for paired devices
Security Mode	2	Security mode
Page Scan Mode	Connectable	Connectable/Not connectable for other devices

## Device Functional Modes (continued)

**Table 6. Operation Parameters Stored in LMX9838 (continued)**

PARAMETER	DEFAULT VALUE	DESCRIPTION
Inquiry Scan Mode	Discoverable	Discoverable/Not Discoverable/Limited Discoverable for other devices
Default Link Policy	All modes allowed	Configures modes allowed for incoming or outgoing connections (Role switch, Hold mode, Sniff mode...)
Default Link Timeout	20 seconds	The Default Link Timeout configures the timeout, after which the link is assumed lost, if no packages have been received from the remote device
Event Filter	Standard LMX9838 events reported	Defines the level of reporting on the UART - no events - standard events - standard including ACL link events
Default Audio Settings	none	Configures the settings for the external codec and the air format. • Codecs: - Winbond W681360 - OKI MSM7717 / Winbond W681310 - PCM Slave • Air Format: - CVSD - $\mu$ -Law - A-Law

### 8.4.6 Low Power Modes

The LMX9838 supports different Low Power Modes to reduce power in different operating situations. The modular structure of the LMX9838 allows the firmware to power down unused modules.

The Low power modes have influence on:

- UART transport layer
  - enabling or disabling the interface
- Bluetooth Baseband activity
  - firmware disables LLC and Radio if possible

#### 8.4.6.1 Power Modes

The following LMX9838 power modes, which depend on the activity level of the UART transport layer and the radio activity are defined:

The radio activity level mainly depends on application requirements and is defined by standard bluetooth operations like inquiry/page scanning or an active link.

A remote device establishing or disconnecting a link may also indirectly change the radio activity level.

The UART transport layer by default is enabled on device power up. In order to disable the transport layer the command “Disable Transport Layer” is used. Thus only the Host side command interface can disable the transport layer. Enabling the transport layer is controlled by the HW Wakeup signalling. This can be done from either the Host or the LMX9838. See the *LMX9838 Software User’s Guide*, literature number [SNOA498](#) for detailed information on timing and implementation requirements.

**Table 7. Power Mode Activity**

POWER MODE	UART ACTIVITY	RADIO ACTIVITY	REFERENCE CLOCK
PM0	OFF	OFF	none
PM1	ON	OFF	Main Clock
PM2	OFF	Scanning	Main Clock / 32.768 kHz
PM3	ON	Scanning	Main Clock
PM4	OFF	SPP Link	Main Clock
PM5	ON	SPP Link	Main Clock

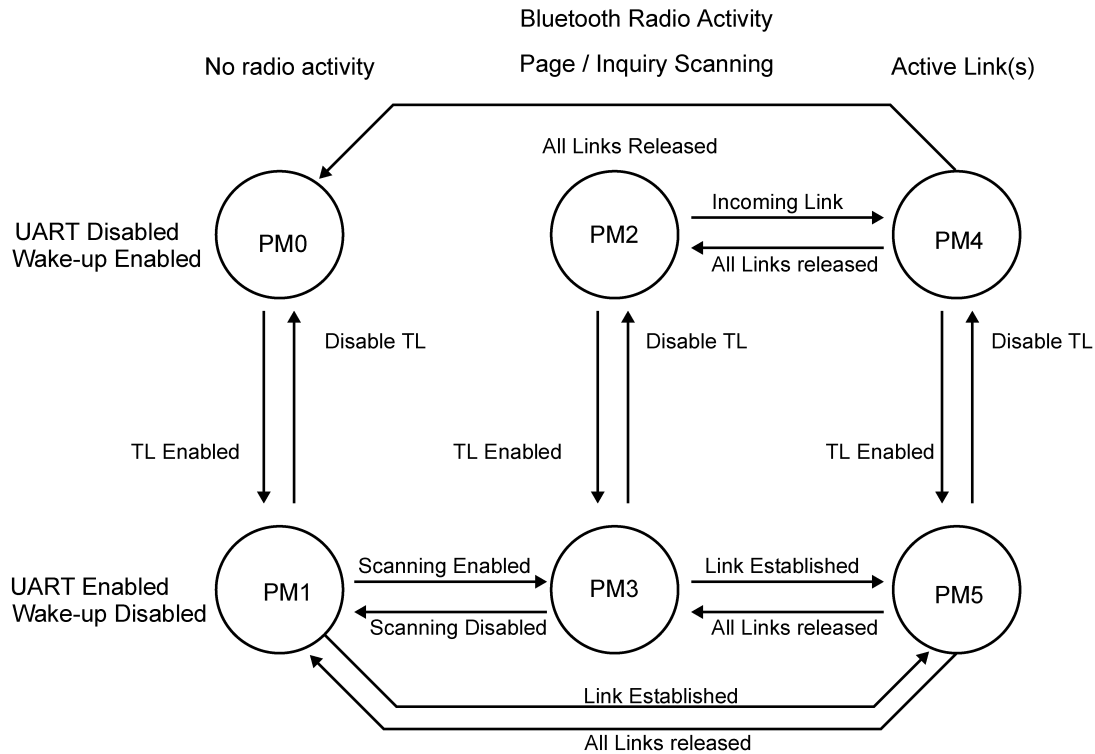

Figure 3. Transition Between Different Hardware Power Modes

### 8.4.7 Enabling and Disabling UART Transport

#### 8.4.7.1 Hardware Wake-up Functionality

In certain usage scenarios the host is able to switch off the transport layer of the LMX9838 in order to reduce power consumption. Afterwards both devices, host and LMX9838 are able to shut down their UART interfaces.

In order to save system connections the UART interface is reconfigured to hardware wake-up functionality. For a detailed timing and command functionality, see the *LMX9838 Software User's Guide, AN-1699* literature number [SNOA498](#). The interface between host and LMX9838 is defined as described in [Figure 4](#).

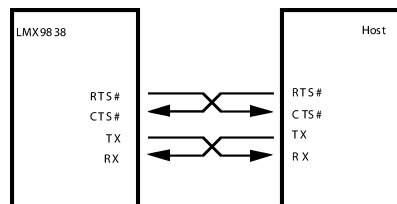

Figure 4. UART NULL Modem Connection

#### 8.4.7.2 Disabling the UART Transport Layer

The Host can disable the UART transport layer by sending the “Disable Transport Layer” Command. The LMX9838 will empty its buffers, send the confirmation event and disable its UART interface. Afterwards the UART interface will be reconfigured to wake up on a falling edge of the CTS pin.

### 8.4.7.3 LMX9838 Enabling The UART Interface

As the Transport Layer can be disabled in any situation the LMX9838 must first make sure the transport layer is enabled before sending data to the host. Possible scenarios can be incoming data or incoming link indicators. If the UART is not enabled the LMX9838 assumes that the Host is sleeping and waking it up by activating RTS. To be able to react on that Wake up, the host has to monitor the CTS pin.

As soon as the host activates its RTS pin, the LMX9838 will first send a confirmation event and then start to transmit the events.

### 8.4.7.4 Enabling the UART Transport Layer From The Host

If the host needs to send data or commands to the LMX9838 while the UART Transport Layer is disabled it must first assume that the LMX9838 is sleeping and wake it up using its RTS signal. When the LMX9838 detects the Wake-Up signal it activates the UART HW and acknowledges the Wake-Up signal by settings its RTS. Additionally the Wake up will be confirmed by a confirmation event. When the Host has received this “Transport Layer Enabled” event, the LMX9838 is ready to receive commands.

## 8.5 Programming - Command Interface

The LMX9838 offers Bluetooth functionality in either a self contained slave functionality or over a simple command interface. The interface is listening on the UART interface.

The following sections describe the protocol transported on the UART interface between the LMX9838 and the host in command mode (see [Figure 5](#)). In Transparent mode, no data framing is necessary and the device does not listen for commands.

### 8.5.1 Framing

The connection is considered “Error free”. But for packet recognition and synchronization, some framing is used. All packets sent in both directions are constructed per the model shown in [Table 8](#).

### 8.5.2 Start and End Delimiter

The “STX” char is used as start delimiter: STX = 0x02. ETX = 0x03 is used as end delimiter.

### 8.5.3 Packet Type ID

This byte identifies the type of packet. See [Table 9](#) for details.

### 8.5.4 Opcode

The opcode identifies the command to execute. The opcode values can be found within the *LMX9838 Software User’s Guide* included with the LMX9838 Evaluation Board.

### 8.5.5 Data Length

Number of bytes in the Packet Data field. The maximum size is defined with 333 data bytes per packet.

### 8.5.6 Checksum

This is a simple Block Check Character (BCC) checksum of the bytes “Packet type”, “Opcode” and “Data Length”. The BCC checksum is calculated as low byte of the sum of all bytes (that is, if the sum of all bytes is 0x3724, the checksum is 0x24).

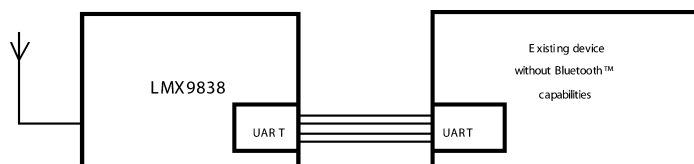

**Figure 5. Bluetooth Functionality**

**Programming - Command Interface (continued)**

**Table 8. Package Framing**

START DELIMITER	PACKET TYPE ID	OPCODE	DATA LENGTH	CHECK SUM	PACKET DATA	END DELIMITER
1 Byte	1 Byte	1 Byte	2 Bytes	1 Byte	<Data Length> Bytes	1 Byte
	----- Checksum -----					

**Table 9. Packet Type Identification**

ID	DIRECTION	DESCRIPTION
0x52 'R'	REQUEST (REQ)	A request sent to the Bluetooth module. All requests are answered by exactly one confirm.
0x43 'C'	Confirm (CFM)	The Bluetooth modules confirm to a request. All requests are answered by exactly one confirm.
0x69 'i'	Indication (IND)	Information sent from the Bluetooth module that is not a direct confirm to a request. Indicating status changes, incoming links, or unrequested events.
0x72 'r'	Response (RES)	An optional response to an indication. This is used to respond to some type of indication message.

**8.5.7 Command Set Overview**

The LMX9838 has a well defined command set to:

- Configure the device:
  - Hardware settings
  - Local Bluetooth parameters
  - Service database
- Set up and handle links

Table 10 through Table 20 show the actual command set and the events coming back from the device. A full documented description of the commands can be found in the *LMX9838 Software User's Guide*, literature number [SNOA498](#).

Note: For standard Bluetooth operation only commands from Table 10 through Table 12 will be used. Most of the remaining commands are for configuration purposes only.

**Table 10. Device Discovery**

COMMAND	EVENT	DESCRIPTION
Inquiry	Inquiry Complete	Search for devices
	Device Found	Lists BDADDR and class of device
Remote Device Name	Remote Device Name Confirm	Get name of remote device

**Table 11. SDAP Client Commands**

COMMAND	EVENT	DESCRIPTION
SDAP Connect	SDAP Connect Confirm	Create an SDP connection to remote device
SDAP Disconnect	SDAP Disconnect Confirm	Disconnect an active SDAP link
	Connection Lost	Notification for lost SDAP link
SDAP Service Browse	Service Browse Confirm	Get the services of the remote device
SDAP Service Search	SDAP Service Search Confirm	Search a specific service on a remote device
SDAP Attribute Request	SDAP Attribute Request Confirm	Searches for services with specific attributes

**Table 12. SPP Link Establishment**

COMMAND	EVENT	DESCRIPTION
Establish SPP Link	Establishing SPP Link Confirm	Initiates link establishment to a remote device
	Link Established	Link successfully established
	Incoming Link	A remote device established a link to the local device
Set Link Timeout	Set Link Timeout Confirm	Confirms the Supervision Timeout for the existing Link
Get Link Timeout	Get Link Timeout Confirm	Get the Supervision Timeout for the existing Link
Release SPP Link	Release SPP Link Confirm	Initiate release of SPP link
SPP Send Data	SPP Send Data Confirm	Send data to specific SPP port
	Incoming Data	Incoming data from remote device
Transparent Mode	Transparent Mode Confirm	Switch to Transparent mode on the UART

**Table 13. Storing Default Connections**

COMMAND	EVENT	DESCRIPTION
Connect Default Connection	Connect Default Connection Confirm	Connects to either one or all stored default connections
Store Default Connection	Store Default Connection Confirm	Store device as default connection
Get list of Default Connections	List of Default Devices	
Delete Default Connections	Delete Default Connections Confirm	

**Table 14. Bluetooth Low Power Modes**

COMMAND	EVENT	DESCRIPTION
Set Default Link Policy	Set Default Link Policy Confirm	Defines the link policy used for any incoming or outgoing link
Get Default Link Policy	Get Default Link Policy Confirm	Returns the stored default link policy
Set Link Policy	Set Link Policy Confirm	Defines the modes allowed for a specific link
Get Link Policy	Get Link Policy Confirm	Returns the actual link policy for the link
Enter Sniff Mode	Enter Sniff Mode Confirm	
Exit Sniff Mode	Exit Sniff Mode Confirm	
Enter Hold Mode	Enter Hold Mode Confirm	
	Power Save Mode Changed	Remote device changed power save mode on the link

**Table 15. Audio Control Commands**

COMMAND	EVENT	DESCRIPTION
Establish SCO Link	Establish SCO Link Confirm	Establish SCO Link on existing RfComm Link
	SCO Link Established Indicator	A remote device has established a SCO link to the local device
Release SCO Link	Release SCO Link Confirm	Release SCO Link Audio Control
	SCO Link Released Indicator	SCO Link has been released
Change SCO Packet Type	Change SCO Packet Type Confirm	Changes Packet Type for existing SCO link
	SCO Packet Type changed indicator	SCO Packet Type has been changed
Set Audio Settings	Set Audio Settings Confirm	Set Audio Settings for existing Link
Get Audio Settings	Get Audio Settings Confirm	Get Audio Settings for existing Link
Set Volume	Set Volume Confirm	Configure the volume
Get Volume	Get Volume Confirm	Get current volume setting
Mute	Mute Confirm	Mutes the microphone input

**Table 16. Wake Up Functionality**

COMMAND	EVENT	DESCRIPTION
Disable Transport Layer	Transport Layer Enabled	Disabling the UART Transport Layer and activates the Hardware Wakeup function

**Table 17. SPP Port Configuration and Status**

COMMAND	EVENT	DESCRIPTION
Set Port Config	Set Port Config Confirm	Set port setting for the virtual serial port link over the air
Get Port Config	Get Port Config Confirm	Read the actual port settings for a virtual serial port
	Port Config Changed	Notification if port settings were changed from remote device
SPP Get Port Status	SPP Get Port Status Confirm	Returns status of DTR, RTS (for the active RFComm link)
SPP Port Set DTR	SPP Port Set DTR Confirm	Sets the DTR bit on the specified link
SPP Port Set RTS	SPP Port Set RTS Confirm	Sets the RTS bit on the specified link
SPP Port BREAK	SPP Port BREAK	Indicates that the host has detected a break
SPP Port Overrun Error	SPP Port Overrun Error Confirm	Used to indicate that the host has detected an overrun error
SPP Port Parity Error	SPP Port Parity Error Confirm	Host has detected a parity error
SPP Port Framing Error	SPP Port Framing Error Confirm	Host has detected a framing error
	SPP Port Status Changed	Indicates that remote device has changed one of the port status bits

**Table 18. Local Bluetooth Settings**

COMMAND	EVENT	DESCRIPTION
Read Local Name	Read Local Name Confirm	Read actual friendly name of the device
Write Local Name	Write Local Name Confirm	Set the friendly name of the device
Read Local BDADDR	Read Local BDADDR Confirm	
Change Local BDADDR	Change Local BDADDR Confirm	<b>Note:</b> The BDADDR is programmed by TI. It cannot be retrieved if erased!
Store Class of Device	Store Class of Device Confirm	
Set Scan Mode	Set Scan Mode Confirm	Change mode for discoverability and connectability
	Set Scan Mode Indication	Reports end of Automatic limited discoverable mode
Get Fixed Pin	Get Fixed Pin Confirm	Reads current PinCode stored within the device
Set Fixed Pin	Set Fixed Pin Confirm	Set the local PinCode
	PIN request	a PIN code is requested during authentication of an ACL link
Get Security Mode	Get Security Mode Confirm	Get actual Security mode
Set Security Mode	Set Security Mode Confirm	Configure Security mode for local device (default 2)
Remove Pairing	Remove Pairing Confirm	Remove pairing with a remote device
List Paired Devices	List of Paired Devices	Get list of paired devices stored in the LMX9838 data memory
Set Default Link Timeout	Set Default Link Timeout Confirm	Store default link supervision timeout
Get Default Link Timeout	Get Default Link Timeout Confirm	Get stored default link supervision timeout
Force Master Role	Force Master Role Confirm	Enables/Disables the request for master role at incoming connections



**Table 19. Local Service Database Configuration**

COMMAND	EVENT	DESCRIPTION
Store generic SDP Record	Store SDP Record Confirm	Create a new service record within the service database
Enable SDP Record	Enable SDP Record Confirm	Enable or disable SDP records
Delete All SDP Records	Delete All SDP Records Confirm	
Ports to Open	Ports to Open Confirmed	Specify the RfComm Ports to open on startup

**Table 20. Local Hardware Commands**

COMMAND	EVENT	DESCRIPTION
Set Default Audio Settings	Set Default Audio Settings Confirm	Configure Default Settings for Audio Codec and Air Format, stored in NVS
Get Default Audio Settings	Get Default Audio Settings Confirm	Get stored Default Audio Settings
Set Event Filter	Set Event Filter Confirm	Configures the reporting level of the command interface
Get Event Filter	Get Event Filter Confirm	Get the status of the reporting level
Read RSSI	Read RSSI Confirm	Returns an indicator for the incoming signal strength
Change UART Speed	Change UART Speed Confirm	Set specific UART speed; needs proper ISEL pin setting
Change UART Settings	Change UART Settings Confirm	Change configuration for parity and stop bits
Test Mode	Test Mode Confirm	Enable Bluetooth, EMI test, or local loopback
Restore Factory Settings	Restore Factory Settings Confirm	
Reset	Dongle Ready	Soft reset
Firmware Upgrade		Stops the bluetooth firmware and executes the In-system-programming code
Set Clock Frequency	Set Clock Frequency Confirm	Write Clock Frequency setting in the NVS
Get Clock Frequency	Get Clock Frequency Confirm	Read Clock Frequency setting from the NVS
Set PCM Slave Configuration	Set PCM Slave Configuration Confirm	Write the PCM Slave Configuration in the NVS
Write ROM Patch	Write ROM Patch Confirm	Store ROM Patch in the Simply Blue module
Read Memory	Read Memory Confirm	Read from the internal RAM
Write Memory	Write Memory Confirm	Write to the internal RAM
Read NVS	Read NVS Confirm	Read from the NVS (EEPROM)
Write NVS	Write NVS Confirm	Write to the NVS (EEPROM)

**Table 21. Initialization Commands**

COMMAND	EVENT	DESCRIPTION
Set Clock and Baudrate	Set Clock and Baudrate Confirm	Write Baseband frequency and Baudrate used
Enter Bluetooth Mode	Enter Bluetooth Mode Confirm	Request SimplyBlue module to enter BT mode
Set Clock and Baudrate	Set Clock and Baudrate Confirm	Write Baseband frequency and Baudrate used

**Table 22. GPIO Control Commands**

COMMAND	EVENT	DESCRIPTION
Set GPIO WPU	Set GPIO WPU Confirm	Enable/Disable weak pull up resistor on GPIOs
Get GPIO Input State	Get GPIO Input States Confirm	Read the status of the GPIOs
Set GPIO Direction	Set GPIO Direction Confirm	Set the GPIOs direction (Input, Output)
Set GPIO Output High	Set GPIO Output High Confirm	Set GPIOs Output to logical High
Set GPIO Output Low	Set GPIO Output Low Confirm	Set GPIOs Output to logical Low

## 9 Application and Implementation

### NOTE

Information in the following applications sections is not part of the TI component specification, and TI does not warrant its accuracy or completeness. TI's customers are responsible for determining suitability of components for their purposes. Customers should validate and test their design implementation to confirm system functionality.

### 9.1 Typical Applications

The following diagrams show two application examples for LMX9838 implementations.

[Figure 6](#) illustrates a cable replacement application, requiring the physical UART interface to a data device like a sensor. The LMX9838 just waits for an incoming link and forwards data between the data device and the bluetooth link. PG6 acts as active link indicator and is used to enable the data transfer from the sensor. A 32.768khz crystal may be used to reduce power consumption while waiting for the incoming link.

[Figure 7](#) shows an example for the connection to a host controller, which can include a simple application to control the LMX9838. The figure also includes the connection to a PCM codec, in case the host controller application includes an audio profile. Reset, OP4 and OP5 are controlled by the host for full control of the LMX9838 status.

Refer to the [Power Supply Schematics](#) section for more detailed descriptions for LMX9838 designs.

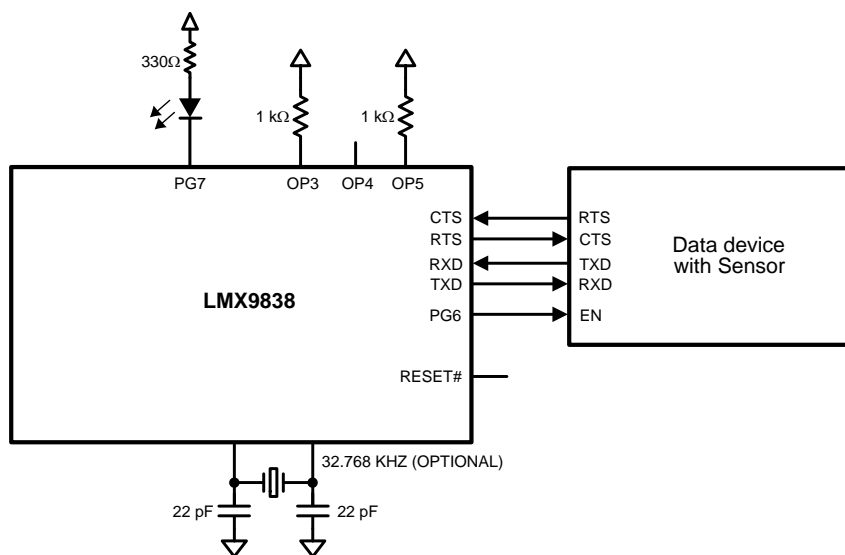

**Figure 6. Example For A Cable Replacement Application**

Typical Applications (continued)

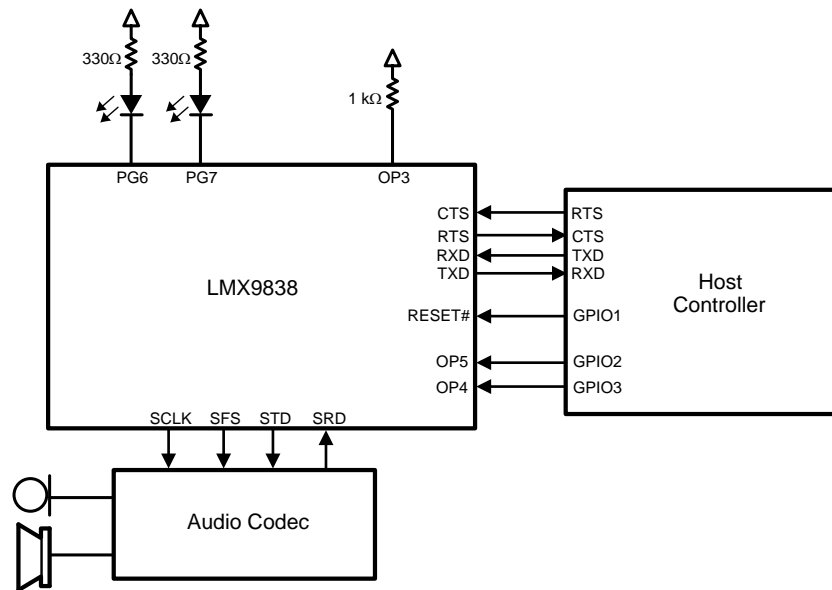

Figure 7. Example For Host Controller Based Application With Audio Support

# LMX9838

SNOSAZ9F – JULY 2007 – REVISED DECEMBER 2014

www.ti.com

## 9.1.1 Design Requirements

### 9.1.1.1 Evaluation Design

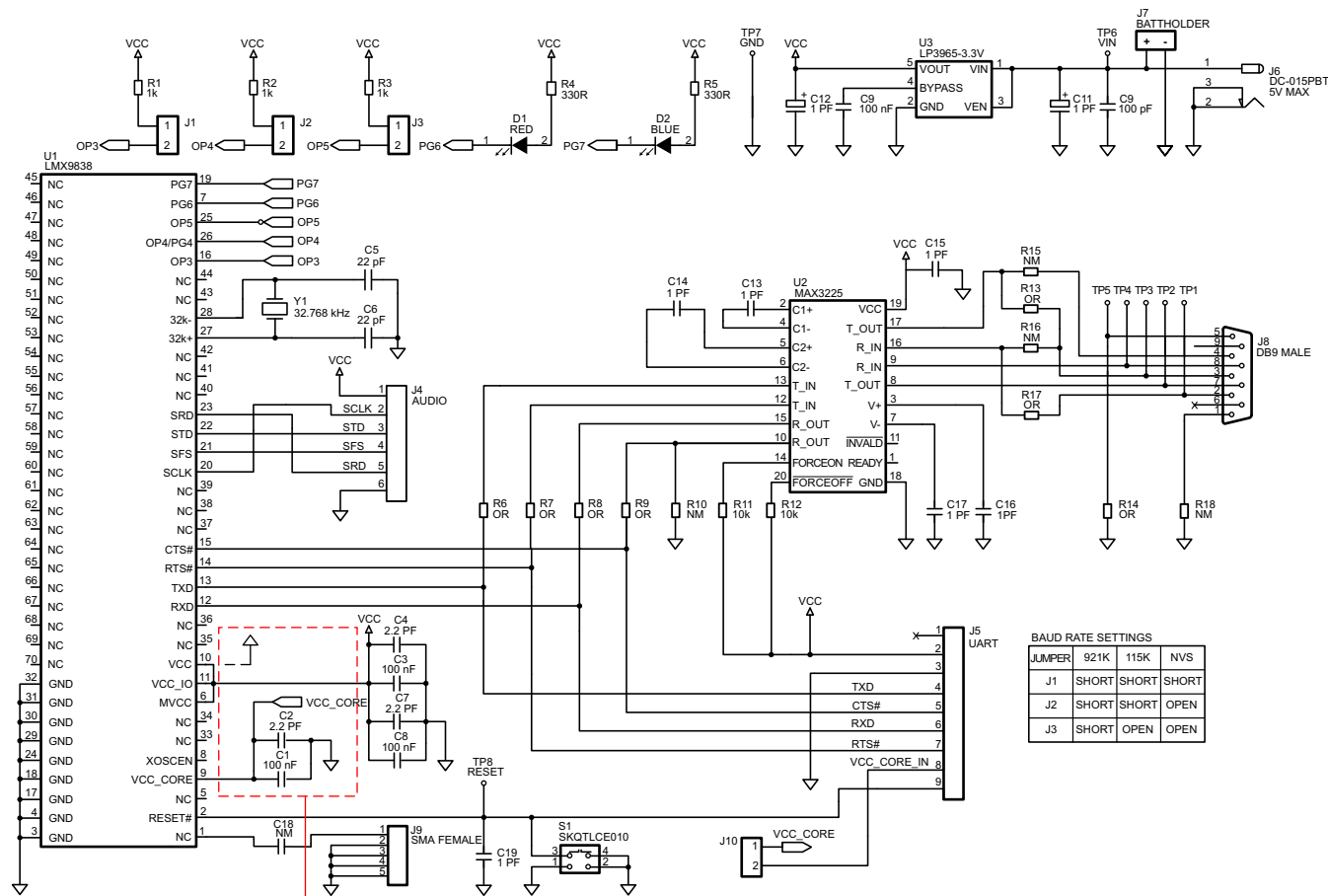

BAUD RATE SETTINGS			
JUMPER	921K	115K	NVS
J1	SHORT	SHORT	SHORT
J2	SHORT	SHORT	OPEN
J3	SHORT	OPEN	OPEN

Network required if using external source.  
 Vcc grounded if Vcc\_core using external source.  
 (for Vcc\_core using external source, refer to figure 12)

Vcc\_core open if using internal regulator.  
 (for Vcc\_core using internal source, refer to figures 10 and 11)

9.1.1.2 Evaluation Design Reflow Profile:

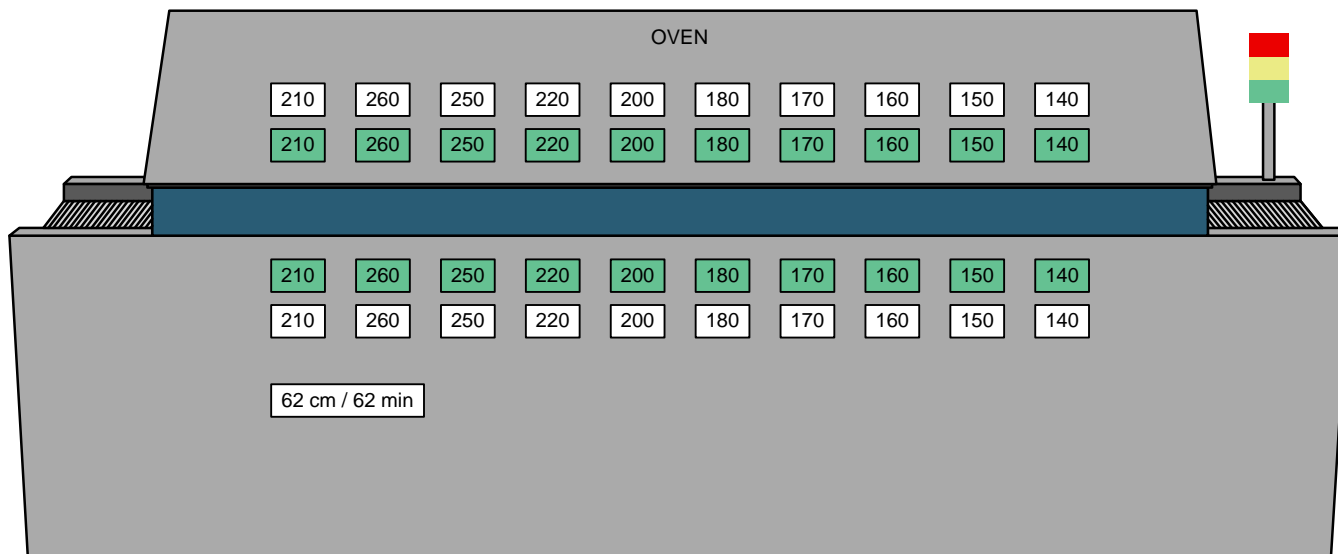

Figure 8. Reflow Temperature Process

9.1.2 Detailed Design Procedure

9.1.2.1 Soldering

The LMX9838 bumps are designed to melt as part of the Surface Mount Assembly (SMA) process. In order to ensure reflow of all solder bumps and maximum solder joint reliability while minimizing damage to the package, recommended reflow profiles should be used.

Table 23, Table 24 and Figure 9 provide the soldering details required to properly solder the LMX9838 to standard PCBs. The illustration serves only as a guide and TI is not liable if a selected profile does not work.

See IPC/JEDEC J-STD-020C, July 2004 for more information.

Table 23. Soldering Details

PARAMETER	VALUE
PCB Land Pad Diameter	13 mil
PCB Solder Mask Opening	19 mil
PCB Finish (HASL details)	Defined by customer or manufacturing facility
Stencil Aperture	17 mil
Stencil Thickness	5 mil
Solder Paste Used	Defined by customer or manufacturing facility
Flux Cleaning Process	Defined by customer or manufacturing facility
Reflow Profiles	See Figure 9

Table 24. Classification Reflow Profiles<sup>(1)(2)</sup>

PROFILE FEATURE	NOPB ASSEMBLY
Average Ramp-Up Rate (T <sub>S</sub> MAX to T <sub>p</sub> )	3°C/second maximum
<b>Preheat:</b>	
Temperature Min (T <sub>S</sub> MIN)	150°C
Temperature Max (T <sub>S</sub> MAX)	200°C
Time (t <sub>S</sub> MIN to t <sub>S</sub> MAX)	60 – 180 seconds

(1) See IPC/JEDEC J-STD-020C, July 2004.

(2) All temperatures refer to the top side of the package, measured on the package body surface.

**Table 24. Classification Reflow Profiles<sup>(1)(2)</sup> (continued)**

PROFILE FEATURE	NOPB ASSEMBLY
Time maintained above: Temperature ( $T_L$ ) Time ( $t_L$ )	217°C 60 – 150 seconds
Peak/Classification Temperature ( $T_p$ )	250 + 0°C
Time within 5°C of actual Peak Temperature ( $t_p$ )	20 – 40 seconds
Ramp-Down Rate	6°C/second maximum
Time 25 °C to Peak Temperature	8 minutes maximum
Reflow Profiles	See <a href="#">Figure 9</a>

### 9.1.3 Application Performance Plots

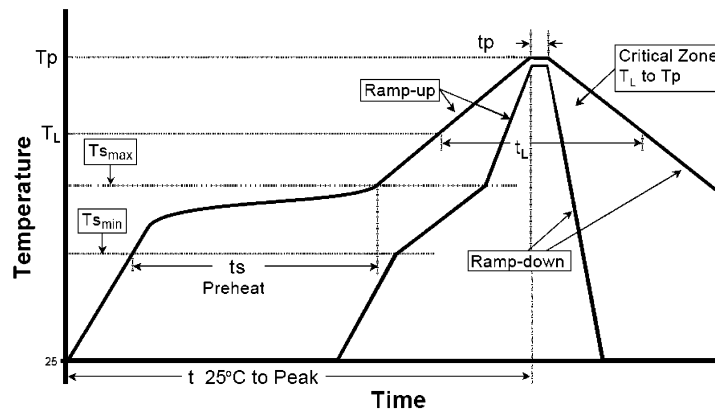
**Figure 9. Typical Reflow Profiles**

## 10 Power Supply Recommendations

### 10.1 Power Supply Schematics

The different possibilities to power supply the LMX9838 depend on the IO interface logic level.

Figure 10 represents an example of system functional schematic for the LMX9838 using a 3.0V to 3.3V IO interface.

Figure 11 represents an example of system functional schematic for the LMX9838 using a 2.5V to 3.0V IO interface.

Figure 12 represents an example of system functional schematic for the LMX9838 using a 1.8V to 2.5V IO interface.

Figure 13 represents an example of system functional schematic for the LMX9838 using a 1.8V IO interface.

#### 10.1.1 Frequency and BAUDRATE Selection

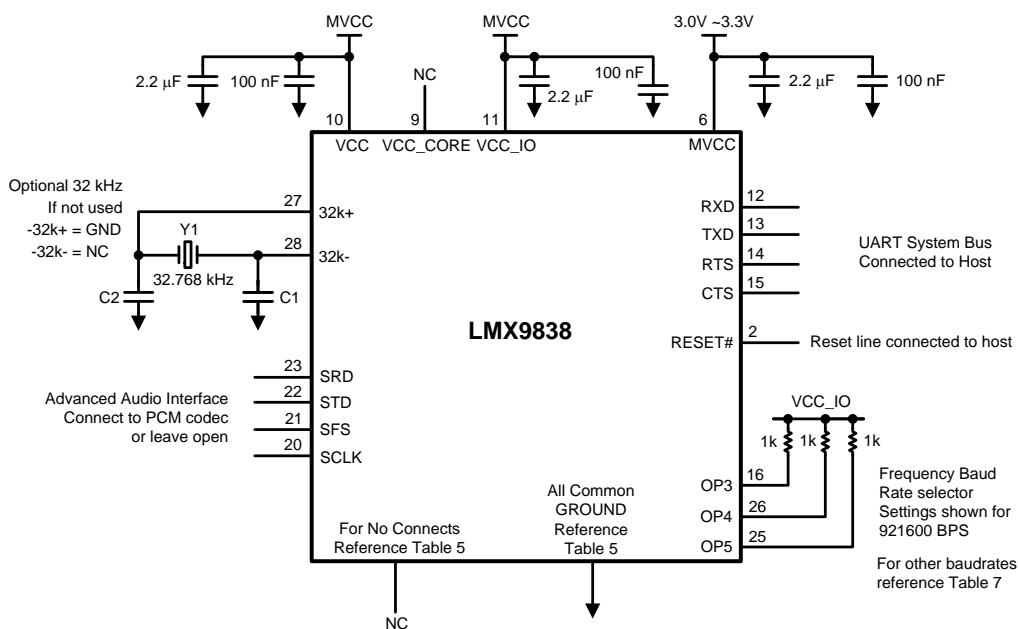

**Notes:**

Capacitor values C1 and C2 may vary depending on design and crystal manufacturer specification.

**Figure 10. 3.0 V to 3.3 V Example Functional System Schematic**

Power Supply Schematics (continued)

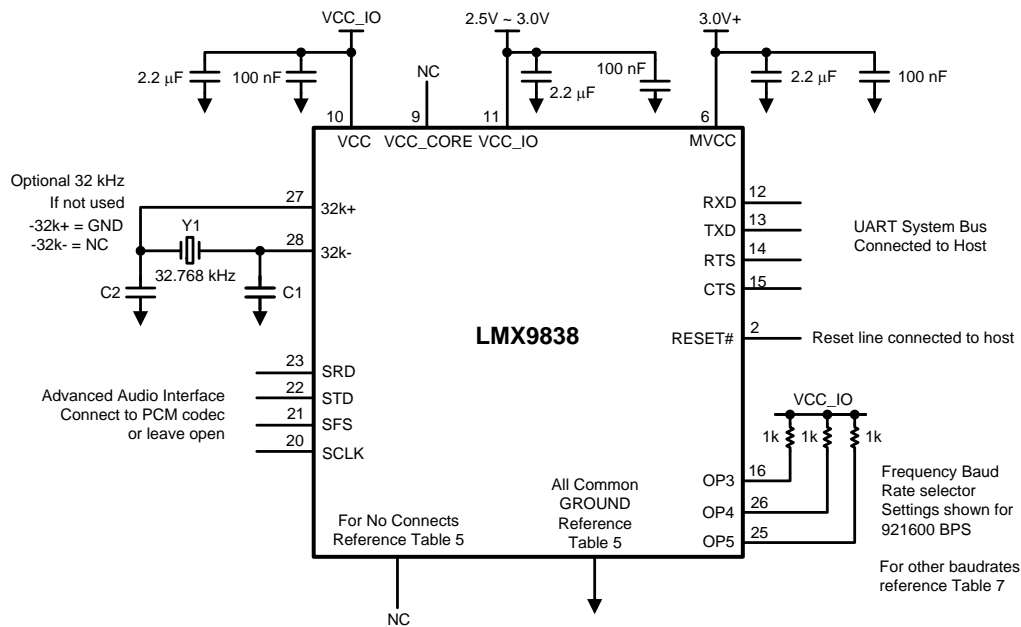

Notes:  
 Capacitor values C1 and C2 may vary depending on design and crystal manufacturer specification.  
 MVCC can be connected to 3.0V and above in this configuration. Please see [Recommended Operating Conditions](#).

Figure 11. 2.5 V to 3.0 V Example Functional System Schematic

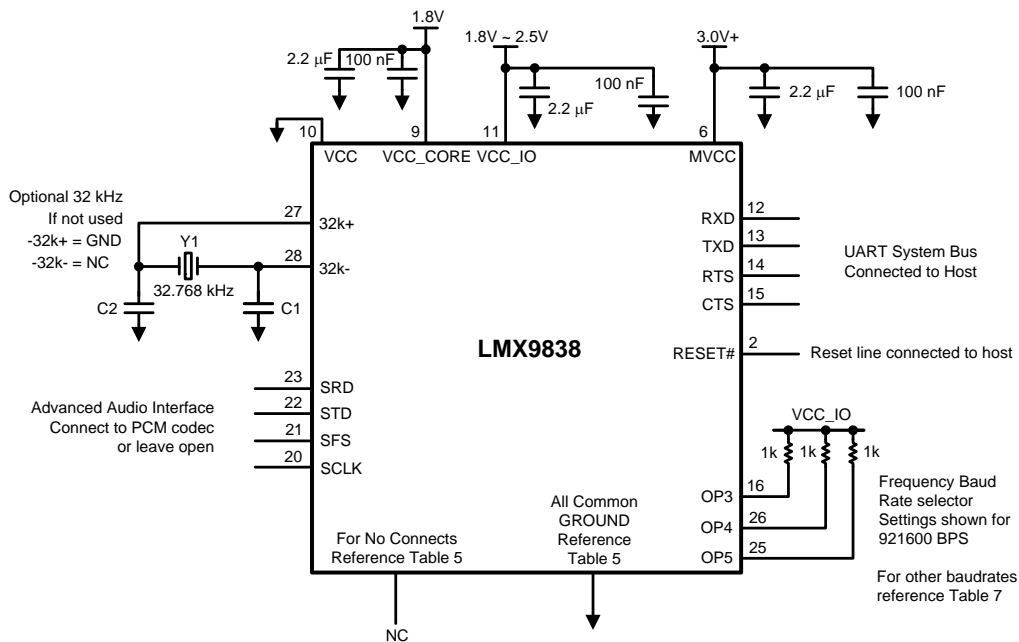

Notes:  
 Capacitor values C1 and C2 may vary depending on design and crystal manufacturer specification.  
 MVCC can be connected to 3.0V and above in this configuration. Please see [Recommended Operating Conditions](#).

Figure 12. 1.8 V to 2.5 V Example Functional System Schematic



## Power Supply Schematics (continued)

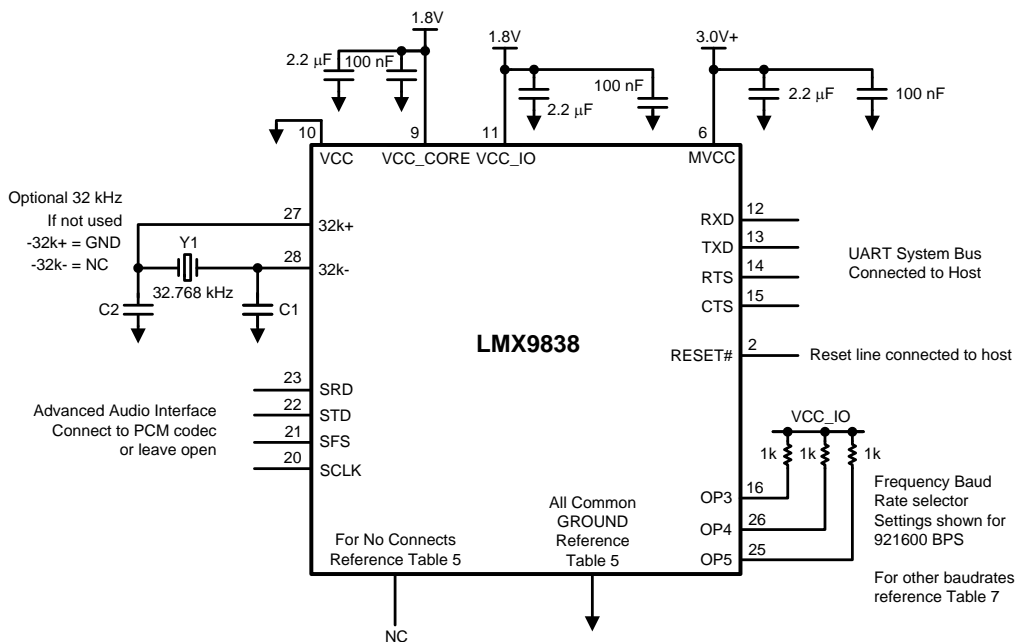

**Notes:**

Capacitor values C1 and C2 may vary depending on design and crystal manufacturer specification.

MVCC can be connected to 3.0V and above in this configuration. Please see [Recommended Operating Conditions](#).

**Figure 13. 1.8 V Example Functional System Schematic**

## 10.2 Filtered Power Supply

It is important to provide the LMX9838 with adequate ground planes and a filtered power supply. It is highly recommended that a 2.2 µF and a 100 nF bypass capacitor be placed as close as possible to the power supply pins V<sub>CC</sub>, MV<sub>CC</sub>, and V<sub>CC\_IO</sub>.

## 10.3 Power Up

The LMX9838 contains an internal EEPROM initialized during power up or hardware reset. During this initialization phase it is recommended not to:

- Send a command to the LMX9838: The command will be ignored.
- Power OFF/ON the LMX9838: The EEPROM initialization phase will be interrupted and the EEPROM will not be recognized which leaves the device in a lockup situation.
- Issue a Hardware Reset: The EEPROM initialization phase will be interrupted and the EEPROM will not be recognized which leaves the device in a lockup situation.

Once the initialization phase is completed the module sends the “SimplyBlue Ready Event” (refer to the *LMX9838 Software User's Guide, AN-1699 [SNOA498]*) to declare its fully functional state.

It is therefore recommended to wait for the “SimplyBlue Ready Event” message before starting using the LM9838 by sending a command or issuing a Reset or Power On cycle.

**Power Up (continued)**

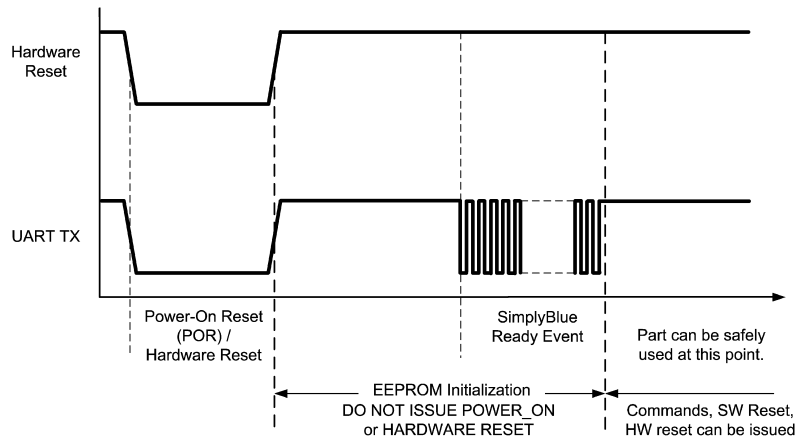

**Figure 14. LMX9838 Power-Up Sequence**

## 11 Regulatory Compliance

The LMX9838 has been tested and approved to be compliant to the following regulatory standards:

### CE Compliance:

- EN 300 328 v1.8.1
- EN 301 489-17 v2.2.1

### IC Compliance:

- IC-1520A-LMX9838
- RSS-GEN Issue 1
- RSS-210 Issue 7 Annex 8 and RSS-GEN issue 2

### FCC Compliance:

- FCC ID: ED9LMX9838
- FCC Part 15 Subpart C

### Japan MIC Compliance:

- Type Certification No. 007-AB0235

### 11.1 FCC Instructions

#### 11.1.1 Safety Information For RF Exposure

##### 11.1.1.1 FCC Radiation Exposure Statement:

This module may only be installed by the OEM or an OEM integrator. The antenna used for this transmitter must not be co-located or operating in conjunction with any other antenna or transmitter. OEM integrators and End-users and installers must be provided with antenna installation instructions and transmitter operating conditions for satisfying RF exposure compliance.

Only the antenna filed under FCC ID: ED9LMX9838 can be used with this device.

##### 11.1.1.2 End Product Labeling

FCC ID label on the final system must be labeled with “Contains TX FCC ID: ED9LMX9838” or “Contains transmitter module FCC ID: ED9LMX9838”.

IC label on the final system must be labeled with “Contains TX IC: 1520A-LMX9838” or “Contains transmitter module IC: 1520A-LMX9838”.

##### 11.1.1.3 End Product Manual Information

In the user manual, final system integrator must ensure that there is no instruction provided in the user manual to install or remove the transmitter module.

LMX9838SB must be installed and used in strict accordance with the manufacturer’s instructions as described in the user documentation that comes with the product.

The following information is required to be incorporated in the user manual of final system.

### USA-Federal Communications Commission (FCC)

This equipment has been tested and found to comply with the limits for a Class B digital device, pursuant to Part 15 of FCC Rules. These limits are designed to provide reasonable protection against harmful interference in a residential installation. This equipment generates, uses, and can radiate radio frequency energy. If not installed and used in accordance with the instructions, it may cause harmful interference to radio communications. However, there is no ensured specification that interference will not occur in a particular installation.

If this equipment does cause harmful interference to radio or television reception, which can be determined by tuning the equipment off and on, the user is encouraged to try and correct the interference by one or more of the following measures:

- Reorient or relocate the receiving antenna.
- Increase the distance between the equipment and the receiver.

**FCC Instructions (continued)**

- Connect the equipment to outlet on a circuit different from that to which the receiver is connected.
- Consult the dealer or an experienced radio/TV technician for help.

Any changes or modifications not expressly approved by the party responsible for compliance could void the user's authority to operate the equipment.

**Caution: Exposure to Radio Frequency Radiation.**

This device must not be co-located or operating in conjunction with any other antenna or transmitter.

**Canada – Industry Canada (IC)**

This device complies with RSS 210 of Industry Canada.

Operation is subject to the following two conditions:

- (1) this device may not cause interference, and
- (2) this device must accept any interference, including interference that may cause undesired operation of this device."

L' utilisation de ce dispositif est autorisée seulement aux conditions suivantes :

- (1) il ne doit pas produire d'interférence et
- (2) l' utilisateur du dispositif doit être prêt à accepter toute interférence radioélectrique reçue, même si celle-ci est susceptible de compromettre le fonctionnement du dispositif.

**Caution: Exposure to Radio Frequency Radiation.**

The installer of this radio equipment must ensure that the antenna is located or pointed such that it does not emit RF field in excess of Health Canada limits for the general population; consult Safety Code 6, obtainable from Health Canada's website [www.hc-sc.gc.ca/rpb](http://www.hc-sc.gc.ca/rpb).

**FCC Instructions (continued)**



**CERTIFICATE for TYPE CERTIFICATION**

<b>Applicant</b>	Texas Instruments Inc.
<b>Address and representative</b>	12500 TI Blvd., Dallas, TX-75243, USA Mr. Richard Templeton
<b>Category of specific radio equipment</b>	Radio equipment for Article 2-1-19 of Certification Ordinance
<b>Manufacturer</b>	Texas Instruments Inc.
<b>Model or Product Name</b>	Bluetooth 2.0 Module: Model:LMX9838
<b>Type of radio wave, frequency and antenna power</b>	FID 2402 MHz~2480 MHz (1 MHz Interval, 79 Channels) 0.000018 W/MHz~0.000063 W/MHz
<b>Type Certification No.</b>	007-AB0235
<b>Date of Certification</b>	November 6, 2013

UL Japan, Inc. hereby declares that this equipment is certified for type certification pursuant to Article 38-24-1 of the Radio Law (Law No. 131 of 1950).

UL Japan, Inc.  
Verification Service  
WiSE(Wireless - interoperability - Security - EMC)  
Radio Certification Section  
4383-326 Asama-cho, Ise-shi, Mie-ken, 516-0021 Japan  
TEL: +81-596-24-8116 FAX: +81-596-8095

Note 1: Whenever there has been a change in the information mentioned in Item (1) of Paragraph 4 of Article 17 of ordinance concerning technical regulations conformity certification etc of specified radio equipment, a certified dealer shall submit without delay to the Minister of Internal Affairs and Communications under Paragraph 5 and 6 of Article 17 of ordinance concerning technical regulations conformity certification etc of specified radio equipment.

Note2: A certified dealer shall conduct an examination on specified radio equipment and maintain the examination records as Specified by Paragraph 2 of Article 38-25 of Japanese Radio Law.

00183 1/1

**Figure 15.**

## 12 Device and Documentation Support

### 12.1 Device Support

LMX9838DONGLE Evaluation Module <http://www.ti.com/tool/lmx9838dongle>

### 12.2 Documentation Support

#### 12.2.1 Related Documentation

Application Notes, Software, and Tools <http://www.ti.com/tool/lmx9838-sw>

*LMX9838 Software User's Guide*, [SNOA498](#)

### 12.3 Trademarks

Bluetooth is a registered trademark of Bluetooth SIG, Inc.  
All other trademarks are the property of their respective owners.

### 12.4 Electrostatic Discharge Caution



These devices have limited built-in ESD protection. The leads should be shorted together or the device placed in conductive foam during storage or handling to prevent electrostatic damage to the MOS gates.

### 12.5 Glossary



[SLYZ022](#) — *TI Glossary*.

This glossary lists and explains terms, acronyms, and definitions.

## 13 Mechanical, Packaging, and Orderable Information

The following pages include mechanical, packaging, and orderable information. This information is the most current data available for the designated devices. This data is subject to change without notice and revision of this document. For browser-based versions of this data sheet, refer to the left-hand navigation.

**PACKAGING INFORMATION**

Orderable Device	Status (1)	Package Type	Package Drawing	Pins	Package Qty	Eco Plan (2)	Lead/Ball Finish (6)	MSL Peak Temp (3)	Op Temp (°C)	Device Marking (4/5)	Samples
LMX9838SB/NOPB	ACTIVE	PLGA	NAW	70	135	Green (RoHS & no Sb/Br)	POST-PLATE	Level-4-250C-72 HR	-40 to 85	LMX9838SB FCC ID: ED9LMX9838 IC: 1520A-LMX9838	
LMX9838SBX/NOPB	ACTIVE	PLGA	NAW	70	1000	Green (RoHS & no Sb/Br)	POST-PLATE	Level-4-250C-72 HR	-40 to 85	LMX9838SB FCC ID: ED9LMX9838 IC: 1520A-LMX9838	

(1) The marketing status values are defined as follows:

**ACTIVE:** Product device recommended for new designs.

**LIFEBUY:** TI has announced that the device will be discontinued, and a lifetime-buy period is in effect.

**NRND:** Not recommended for new designs. Device is in production to support existing customers, but TI does not recommend using this part in a new design.

**PREVIEW:** Device has been announced but is not in production. Samples may or may not be available.

**OBSOLETE:** TI has discontinued the production of the device.

(2) Eco Plan - The planned eco-friendly classification: Pb-Free (RoHS), Pb-Free (RoHS Exempt), or Green (RoHS & no Sb/Br) - please check <http://www.ti.com/productcontent> for the latest availability information and additional product content details.

**TBD:** The Pb-Free/Green conversion plan has not been defined.

**Pb-Free (RoHS):** TI's terms "Lead-Free" or "Pb-Free" mean semiconductor products that are compatible with the current RoHS requirements for all 6 substances, including the requirement that lead not exceed 0.1% by weight in homogeneous materials. Where designed to be soldered at high temperatures, TI Pb-Free products are suitable for use in specified lead-free processes.

**Pb-Free (RoHS Exempt):** This component has a RoHS exemption for either 1) lead-based flip-chip solder bumps used between the die and package, or 2) lead-based die adhesive used between the die and leadframe. The component is otherwise considered Pb-Free (RoHS compatible) as defined above.

**Green (RoHS & no Sb/Br):** TI defines "Green" to mean Pb-Free (RoHS compatible), and free of Bromine (Br) and Antimony (Sb) based flame retardants (Br or Sb do not exceed 0.1% by weight in homogeneous material)

(3) MSL, Peak Temp. - The Moisture Sensitivity Level rating according to the JEDEC industry standard classifications, and peak solder temperature.

(4) There may be additional marking, which relates to the logo, the lot trace code information, or the environmental category on the device.

(5) Multiple Device Markings will be inside parentheses. Only one Device Marking contained in parentheses and separated by a "~" will appear on a device. If a line is indented then it is a continuation of the previous line and the two combined represent the entire Device Marking for that device.

(6) Lead/Ball Finish - Orderable Devices may have multiple material finish options. Finish options are separated by a vertical ruled line. Lead/Ball Finish values may wrap to two lines if the finish value exceeds the maximum column width.

**Important Information and Disclaimer:** The information provided on this page represents TI's knowledge and belief as of the date that it is provided. TI bases its knowledge and belief on information provided by third parties, and makes no representation or warranty as to the accuracy of such information. Efforts are underway to better integrate information from third parties. TI has taken and

continues to take reasonable steps to provide representative and accurate information but may not have conducted destructive testing or chemical analysis on incoming materials and chemicals. TI and TI suppliers consider certain information to be proprietary, and thus CAS numbers and other limited information may not be available for release.

In no event shall TI's liability arising out of such information exceed the total purchase price of the TI part(s) at issue in this document sold by TI to Customer on an annual basis.



NAW0070A

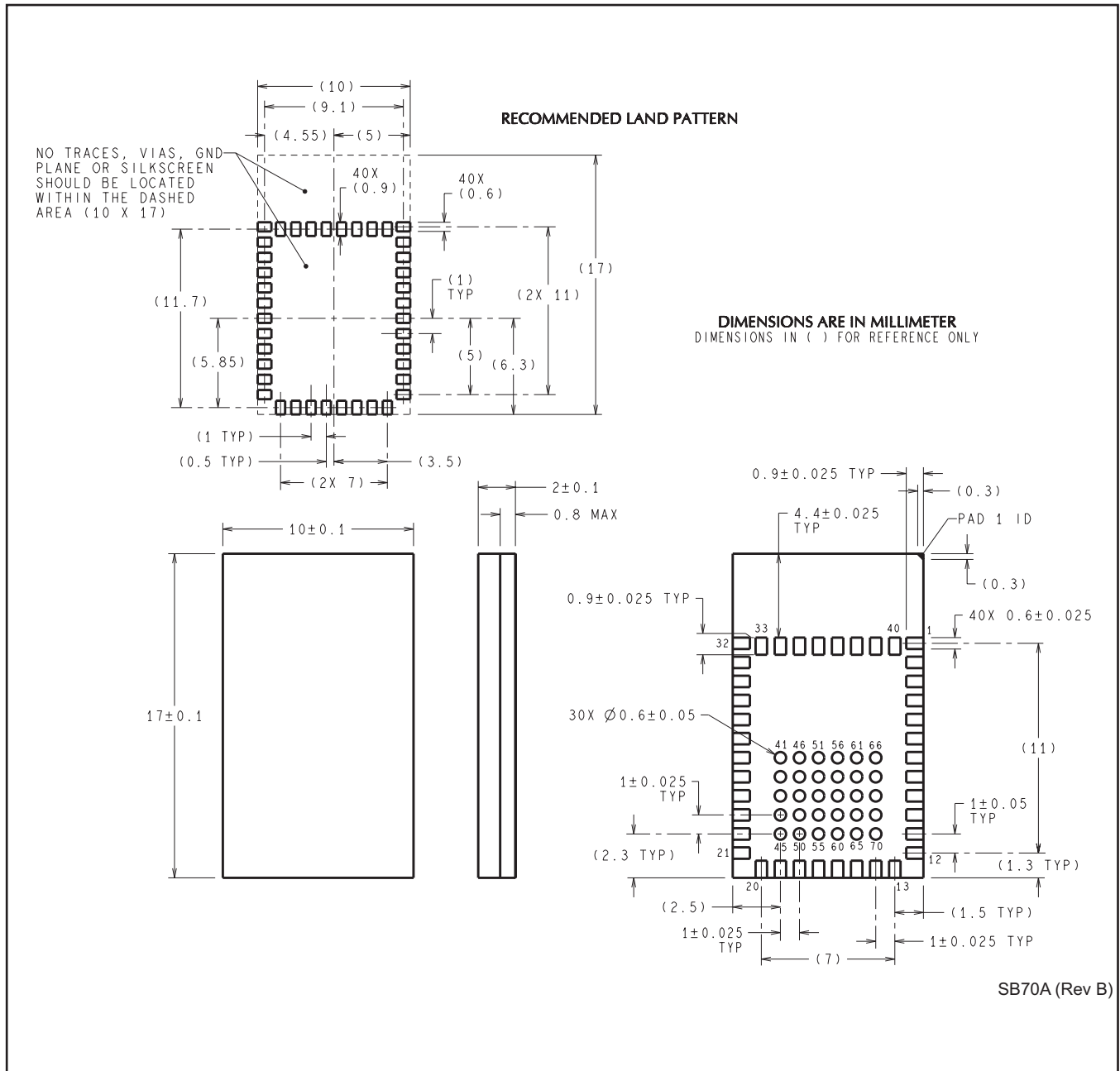

## IMPORTANT NOTICE

Texas Instruments Incorporated and its subsidiaries (TI) reserve the right to make corrections, enhancements, improvements and other changes to its semiconductor products and services per JESD46, latest issue, and to discontinue any product or service per JESD48, latest issue. Buyers should obtain the latest relevant information before placing orders and should verify that such information is current and complete. All semiconductor products (also referred to herein as "components") are sold subject to TI's terms and conditions of sale supplied at the time of order acknowledgment.

TI warrants performance of its components to the specifications applicable at the time of sale, in accordance with the warranty in TI's terms and conditions of sale of semiconductor products. Testing and other quality control techniques are used to the extent TI deems necessary to support this warranty. Except where mandated by applicable law, testing of all parameters of each component is not necessarily performed.

TI assumes no liability for applications assistance or the design of Buyers' products. Buyers are responsible for their products and applications using TI components. To minimize the risks associated with Buyers' products and applications, Buyers should provide adequate design and operating safeguards.

TI does not warrant or represent that any license, either express or implied, is granted under any patent right, copyright, mask work right, or other intellectual property right relating to any combination, machine, or process in which TI components or services are used. Information published by TI regarding third-party products or services does not constitute a license to use such products or services or a warranty or endorsement thereof. Use of such information may require a license from a third party under the patents or other intellectual property of the third party, or a license from TI under the patents or other intellectual property of TI.

Reproduction of significant portions of TI information in TI data books or data sheets is permissible only if reproduction is without alteration and is accompanied by all associated warranties, conditions, limitations, and notices. TI is not responsible or liable for such altered documentation. Information of third parties may be subject to additional restrictions.

Resale of TI components or services with statements different from or beyond the parameters stated by TI for that component or service voids all express and any implied warranties for the associated TI component or service and is an unfair and deceptive business practice. TI is not responsible or liable for any such statements.

Buyer acknowledges and agrees that it is solely responsible for compliance with all legal, regulatory and safety-related requirements concerning its products, and any use of TI components in its applications, notwithstanding any applications-related information or support that may be provided by TI. Buyer represents and agrees that it has all the necessary expertise to create and implement safeguards which anticipate dangerous consequences of failures, monitor failures and their consequences, lessen the likelihood of failures that might cause harm and take appropriate remedial actions. Buyer will fully indemnify TI and its representatives against any damages arising out of the use of any TI components in safety-critical applications.

In some cases, TI components may be promoted specifically to facilitate safety-related applications. With such components, TI's goal is to help enable customers to design and create their own end-product solutions that meet applicable functional safety standards and requirements. Nonetheless, such components are subject to these terms.

No TI components are authorized for use in FDA Class III (or similar life-critical medical equipment) unless authorized officers of the parties have executed a special agreement specifically governing such use.

Only those TI components which TI has specifically designated as military grade or "enhanced plastic" are designed and intended for use in military/aerospace applications or environments. Buyer acknowledges and agrees that any military or aerospace use of TI components which have **not** been so designated is solely at the Buyer's risk, and that Buyer is solely responsible for compliance with all legal and regulatory requirements in connection with such use.

TI has specifically designated certain components as meeting ISO/TS16949 requirements, mainly for automotive use. In any case of use of non-designated products, TI will not be responsible for any failure to meet ISO/TS16949.

### Products

Audio	<a href="http://www.ti.com/audio">www.ti.com/audio</a>
Amplifiers	<a href="http://amplifier.ti.com">amplifier.ti.com</a>
Data Converters	<a href="http://dataconverter.ti.com">dataconverter.ti.com</a>
DLP® Products	<a href="http://www.dlp.com">www.dlp.com</a>
DSP	<a href="http://dsp.ti.com">dsp.ti.com</a>
Clocks and Timers	<a href="http://www.ti.com/clocks">www.ti.com/clocks</a>
Interface	<a href="http://interface.ti.com">interface.ti.com</a>
Logic	<a href="http://logic.ti.com">logic.ti.com</a>
Power Mgmt	<a href="http://power.ti.com">power.ti.com</a>
Microcontrollers	<a href="http://microcontroller.ti.com">microcontroller.ti.com</a>
RFID	<a href="http://www.ti-rfid.com">www.ti-rfid.com</a>
OMAP Applications Processors	<a href="http://www.ti.com/omap">www.ti.com/omap</a>
Wireless Connectivity	<a href="http://www.ti.com/wirelessconnectivity">www.ti.com/wirelessconnectivity</a>

### Applications

Automotive and Transportation	<a href="http://www.ti.com/automotive">www.ti.com/automotive</a>
Communications and Telecom	<a href="http://www.ti.com/communications">www.ti.com/communications</a>
Computers and Peripherals	<a href="http://www.ti.com/computers">www.ti.com/computers</a>
Consumer Electronics	<a href="http://www.ti.com/consumer-apps">www.ti.com/consumer-apps</a>
Energy and Lighting	<a href="http://www.ti.com/energy">www.ti.com/energy</a>
Industrial	<a href="http://www.ti.com/industrial">www.ti.com/industrial</a>
Medical	<a href="http://www.ti.com/medical">www.ti.com/medical</a>
Security	<a href="http://www.ti.com/security">www.ti.com/security</a>
Space, Avionics and Defense	<a href="http://www.ti.com/space-avionics-defense">www.ti.com/space-avionics-defense</a>
Video and Imaging	<a href="http://www.ti.com/video">www.ti.com/video</a>

### TI E2E Community

[e2e.ti.com](http://e2e.ti.com)