

# LMV7271/LMV7275/LMV7272

## Single & Dual, 1.8V Low Power Comparators with Rail-to-Rail Input

### General Description

The LMV727X are rail-to-rail input low power comparators, which are characterized at supply voltage 1.8V, 2.7V and 5.0V. They consume only 9µA supply current per channel while achieving a 800ns propagation delay.

The LMV7271/LMV7275 (single) are available in SC70 and SOT23 packages. The LMV7272 (dual) is available in micro SMD package. With these tiny packages, the PC board area can be significantly reduced. They are ideal for low voltage, low power and space critical designs.

The LMV7271/LMV7272 both feature a push-pull output stage which allows operation with minimum power consumption when driving a load. The LMV7275 features an open drain output stage that allows for wired-OR configurations. The open drain output also offers the advantage of allowing the output to be pulled to any voltage up to 5.5V, regardless of the supply voltage of the LMV7275.

The LMV727X are built with National Semiconductor's advance submicron silicon-gate BiCMOS process. They all have bipolar inputs for improved noise performance and CMOS outputs for rail-to-rail output swing.

### Features

( $V_S = 1.8V$ ,  $T_A = 25^\circ C$ , Typical values unless specified).

- Single or Dual Supplies
- Ultra low supply current 9µA per channel
- Low input bias current 10nA
- Low input offset current 200pA
- Low guaranteed  $V_{OS}$  4mV
- Propagation delay 880ns (20mV overdrive)
- Input common mode voltage range 0.1V beyond rails
- LMV7272 is available in micro SMD package

### Applications

- Mobile communications
- Laptops and PDA's
- Battery powered electronics
- General purpose low voltage applications

### Typical Circuit

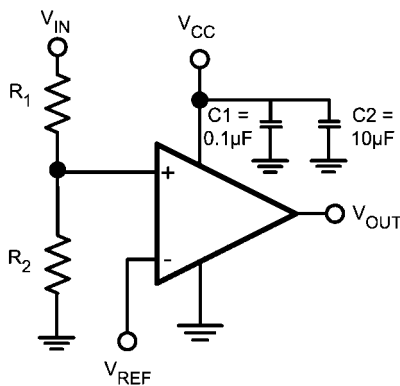

20064024

FIGURE 1. Threshold Detector

Part Number	Single/Dual	Package	Output
LMV7271	Single	SC70, SOT23	Push/Pull
LMV7272	Dual	micro SMD	Push/Pull
LMV7275	Single	SC70, SOT23	Open Drain

**Absolute Maximum Ratings** (Note 1)

If Military/Aerospace specified devices are required, please contact the National Semiconductor Sales Office/ Distributors for availability and specifications.

ESD Tolerance	2KV (Note 2)
	200V (Note 6)
V <sub>IN</sub> Differential	±Supply Voltage
Supply Voltage (V <sup>+</sup> - V <sup>-</sup> )	6V
Voltage at Input/Output pins	V <sup>+</sup> +0.1V, V <sup>-</sup> -0.1V
Soldering Information	
Infrared or Convection (20 sec.)	235°C

Wave Soldering (10 sec.)	260°C
Storage Temperature Range	-65°C to +150°C
Junction Temperature (Note 4)	+150°C

**Operating Ratings** (Note 1)

Supply Voltage Range	1.8V to 5.5V
Temperature Range (Note 3)	-40°C to +85°C
Package Thermal Resistance (Note 3)	
SOT23-5	325°C/W
SC-70	265°C/W
8-Bump Thin micro SMD	220°C/W

**1.8V Electrical Characteristics**

Unless otherwise specified, all limits guaranteed for T<sub>J</sub> = 25°C, V<sup>+</sup> = 1.8V, V<sup>-</sup> = 0V. **Boldface** limits apply at the temperature extremes.

Symbol	Parameter	Condition	Min (Note 5)	Typ (Note 4)	Max (Note 5)	Units
V <sub>OS</sub>	Input Offset Voltage			0.3	4 <b>6</b>	mV
TC V <sub>OS</sub>	Input Offset Temperature Drift	V <sub>CM</sub> = 0.9V (Note 7)		20		uV/°C
I <sub>B</sub>	Input Bias Current			10		nA
I <sub>OS</sub>	Input Offset Current			200		pA
I <sub>S</sub>	Supply Current	LMV7271/LMV7275		9	12 <b>14</b>	μA
		LMV7272		18	25 <b>28</b>	μA
I <sub>SC</sub>	Output Short Circuit Current	Sourcing, V <sub>O</sub> = 0.9V (LMV7271/LMV7272 only)	3.5	6		mA
		Sinking, V <sub>O</sub> = 0.9V	4	6		
V <sub>OH</sub>	Output Voltage High (LMV7271/LMV7272 only)	I <sub>O</sub> = 0.5mA	1.7	1.74		V
		I <sub>O</sub> = 1.5mA	1.47	1.63		
V <sub>OL</sub>	Output Voltage Low	I <sub>O</sub> = -0.5mA		52	100	mV
		I <sub>O</sub> = -1.5mA		166	220	
V <sub>CM</sub>	Input Common Mode Voltage Range	CMRR > 45 dB			1.9	V
			-0.1			V
CMRR	Common Mode Rejection Ratio	0 < V <sub>CM</sub> < 1.8V	46	78		dB
PSRR	Power Supply Rejection Ratio	V <sup>+</sup> = 1.8V to 5V	55	80		dB
I <sub>LEAKAGE</sub>	Output Leakage Current	V <sub>O</sub> = 1.8V (LMV7275 only)		2		pA

**1.8V AC Electrical Characteristics**

Unless otherwise specified, all limits guaranteed for T<sub>J</sub> = 25°C, V<sup>+</sup> = 1.8V, V<sup>-</sup> = 0V, V<sub>CM</sub> = 0.5V, V<sub>O</sub> = V<sub>+</sub>/2 and R<sub>L</sub> > 1MΩ to V<sup>-</sup>. **Boldface** limits apply at the temperature extremes.

Symbol	Parameter	Condition	Min (Note 6)	Typ (Note 5)	Max (Note 6)	Units
t <sub>PHL</sub>	Propagation Delay (High to Low)	Input Overdrive = 20mV Load = 50pF//5kΩ		880		ns
		Input Overdrive = 50mV Load = 50pF//5kΩ		570		ns
t <sub>PLH</sub>	Propagation Delay (Low to High)	Input Overdrive = 20mV Load = 50pF//5kΩ		1100		ns
		Input Overdrive = 50mV Load = 50pF//5kΩ		800		ns

## 2.7V Electrical Characteristics

Unless otherwise specified, all limits guaranteed for  $T_J = 25^\circ\text{C}$ ,  $V_+ = 2.7\text{V}$ ,  $V_- = 0\text{V}$ . **Boldface** limits apply at the temperature extremes.

Symbol	Parameter	Conditions	Min (Note 6)	Typ (Note 5)	Max (Note 6)	Units
$V_{OS}$	Input Offset Voltage			0.3	<b>4</b> <b>6</b>	mV
TC $V_{OS}$	Input Offset Temperature Drift	$V_{CM} = 1.35\text{V}$ (Note 7)		20		$\mu\text{V}/^\circ\text{C}$
$I_B$	Input Bias Current			10		nA
$I_{OS}$	Input offset Current			200		pA
$I_S$	Supply Current	LMV7271/LMV7275		9	<b>13</b> <b>15</b>	$\mu\text{A}$
		LMV7272		18	<b>25</b> <b>28</b>	$\mu\text{A}$
$I_{SC}$	Output Short Circuit Current	Sourcing, $V_O = 1.35\text{V}$ (LMV7271/LMV7272 only)	12	15		mA
		Sinking, $V_O = 1.35\text{V}$	12	15		
$V_{OH}$	Output Voltage High (LMV7271/LMV7272 only)	$I_O = 0.5\text{mA}$	2.63	2.66		V
		$I_O = 2.0\text{mA}$	2.48	2.55		
$V_{OL}$	Output Voltage Low	$I_O = -0.5\text{mA}$		50	70	mV
		$I_O = -2\text{mA}$		155	220	
$V_{CM}$	Input Common Voltage Range	CMRR > 45dB			2.8	V
			-0.1			V
CMRR	Common Mode Rejection Ratio	$0 < V_{CM} < 2.7\text{V}$	46	78		dB
PSRR	Power Supply Rejection Ratio	$V_+ = 1.8\text{V}$ to $5\text{V}$	55	80		dB
$I_{LEAKAGE}$	Output Leakage Current	$V_O = 2.7\text{V}$ (LMV7275 only)		2		pA

## 2.7V AC Electrical Characteristics

Unless otherwise specified, all limits guaranteed for  $T_J = 25^\circ\text{C}$ ,  $V_+ = 2.7\text{V}$ ,  $V_- = 0\text{V}$ ,  $V_{CM} = 0.5\text{V}$ ,  $V_O = V_+/2$  and  $R_L > 1\text{M}\Omega$  to  $V_-$ . **Boldface** limits apply at the temperature extremes.

Symbol	Parameter	Condition	Min (Note 6)	Typ (Note 5)	Max (Note 6)	Units
$t_{PHL}$	Propagation Delay (High to Low)	Input Overdrive = 20mV Load = 50pF//5k $\Omega$		1200		ns
		Input Overdrive = 50mV Load = 50pF//5k $\Omega$		810		ns
$t_{PLH}$	Propagation Delay (Low to High)	Input Overdrive = 20mV Load = 50pF//5k $\Omega$		1300		ns
		Input Overdrive = 50mV Load = 50pF//5k $\Omega$		860		ns

## 5.0V Electrical Characteristics

Unless otherwise specified, all limits guaranteed for  $T_J = 25^\circ\text{C}$ ,  $V_+ = 5\text{V}$ ,  $V_- = 0\text{V}$ . **Boldface** limits apply at the temperature extremes.

Symbol	Parameter	Conditions	Min (Note 6)	Typ (Note 5)	Max (Note 6)	Units
$V_{OS}$	Input Offset Voltage			0.3	<b>4</b> <b>6</b>	mV
TC $V_{OS}$	Input Offset Temperature Drift	$V_{CM} = 2.5\text{V}$ (Note 7)		20		$\mu\text{V}/^\circ\text{C}$
$I_B$	Input Bias Current			10		nA
$I_{OS}$	Input Offset Current			200		pA

Symbol	Parameter	Conditions	Min (Note 6)	Typ (Note 5)	Max (Note 6)	Units
$I_S$	Supply Current	LMV7271/LMV7275		10	14 <b>16</b>	$\mu\text{A}$
		LMV7272		20	27 <b>30</b>	$\mu\text{A}$
$I_{SC}$	Output Short Circuit Current	Sourcing, $V_O = 2.5\text{V}$ (LMV7271/LMV7272 only)	28	34		mA
		Sinking, $V_O = 2.5\text{V}$	28	34		
$V_{OH}$	Output Voltage High (LMV7271/LMV7272 only)	$I_O = 0.5\text{mA}$	4.93	4.96		V
		$I_O = 4.0\text{mA}$	4.70	4.77		
$V_{OL}$	Output Voltage Low	$I_O = -0.5\text{mA}$		27	70	mV
		$I_O = -4.0\text{mA}$		225	300	
$V_{CM}$	Input Common Voltage Range	CMRR > 45dB			5.1	V
			-0.1			
CMRR	Common Mode Rejection Ratio	$0 < V_{CM} < 5.0\text{V}$	46	78		dB
PRSS	Power Supply Rejection Ratio	$V^+ = 1.8\text{V to } 5\text{V}$	55	80		dB
$I_{LEAKAGE}$	Output Leakage Current	$V_O = 5\text{V}$ (LMV7275 only)		2		pA

## 5.0V AC Electrical Characteristics

Unless otherwise specified, all limits guaranteed for  $T_J = 25^\circ\text{C}$ ,  $V^+ = 5.0\text{V}$ ,  $V^- = 0\text{V}$ ,  $V_{CM} = 0.5\text{V}$ ,  $V_O = V^+/2$  and  $R_L > 1\text{M}\Omega$  to  $V^-$ . **Boldface** limits apply at the temperature extremes.

Symbol	Parameter	Condition	Min (Note 6)	Typ (Note 5)	Max (Note 6)	Units
$t_{PHL}$	Propagation Delay (High to Low)	Input Overdrive = 20mV Load = 50pF//5k $\Omega$		2100		ns
		Input Overdrive = 50mV Load = 50pF//5k $\Omega$		1380		ns
$t_{PLH}$	Propagation Delay (Low to High)	Input Overdrive = 20mV Load = 50pF//5k $\Omega$		1800		ns
		Input Overdrive = 50mV Load = 50pF//5k $\Omega$		1100		ns

**Note 1:** Absolute Maximum Ratings indicate limits beyond which damage to the device may occur. Operating Ratings indicate conditions for which the device is intended to be functional, but specific performance is not guaranteed. For guaranteed specifications and the test conditions, see the Electrical Characteristics.

**Note 2:** Human body model, 1.5k $\Omega$  in series with 100pF.

**Note 3:** The maximum power dissipation is a function of  $T_{J(MAX)}$ ,  $\theta_{JA}$ , and  $T_A$ . The maximum allowable power dissipation at any ambient temperature is  $P_D = (T_{J(MAX)} - T_A)/\theta_{JA}$ . All numbers apply for packages soldered directly into a PC board.

**Note 4:** Typical values represent the most likely parametric norm.

**Note 5:** All limits are guaranteed by testing or statistical analysis.

**Note 6:** Machine Model, 0 $\Omega$  in series with 200pF.

**Note 7:** Offset Voltage average drift determined by dividing the change in  $V_{OS}$  at temperature extremes into the total temperature change.

**Note 8:** Electrical Table values apply only for factory testing conditions at the temperature indicated. Factory testing conditions result in very limited self-heating of the device such that  $T_J = T_A$ . No guarantee of parametric performance is indicated in the electrical tables under conditions of internal self heating where  $T_J > T_A$ . Absolute Maximum Ratings indicate junction temperature limits beyond which the device may be permanently degraded, either mechanically or electrically.

## Connection Diagrams

**5-Pin SOT23/SC70 (LMV7271/LMV7275)**

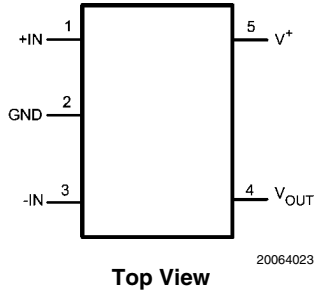

**8-Bump micro SMD (LMV7272)**

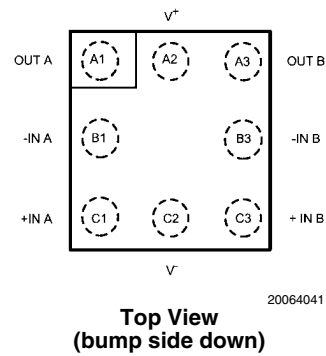

## Ordering Information

Package	Part Number	Package Marking	Transport Media	NSC Drawing
5-Pin SOT23	LMV7271MF	C25A	1k Units Tape and Reel	MF05A
	LMV7271MFX		3k Units Tape and Reel	
	LMV7275MF	C26A	1k Units Tape and Reel	
	LMV7275MFX		3k Units Tape and Reel	
5-Pin SC70	LMV7271MG	C34	1k Units Tape and Reel	MAA05A
	LMV7271MGX		3k Units Tape and Reel	
	LMV7275MG	C35	1k Units Tape and Reel	
	LMV7275MGX		3k Units Tape and Reel	
8-Bump micro SMD	LMV7272TL	I 01	250 Units Tape and Reel	TLA08AAA
	LMV7272TLX		3k Units Tape and Reel	

**Typical Performance Characteristics** ( $T_A = 25^\circ\text{C}$ , Unless otherwise specified).

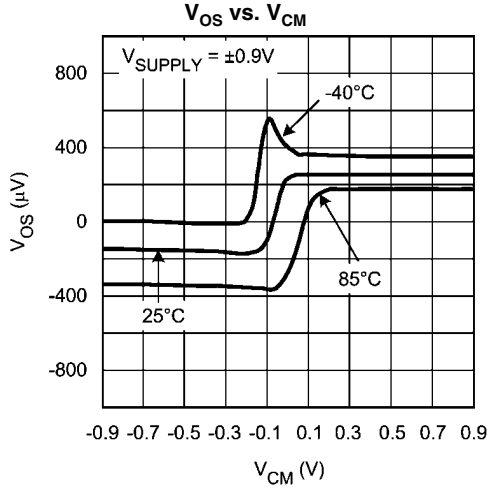

20064028

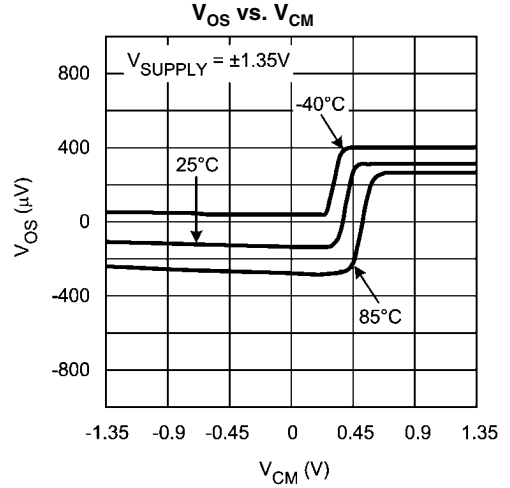

20064029

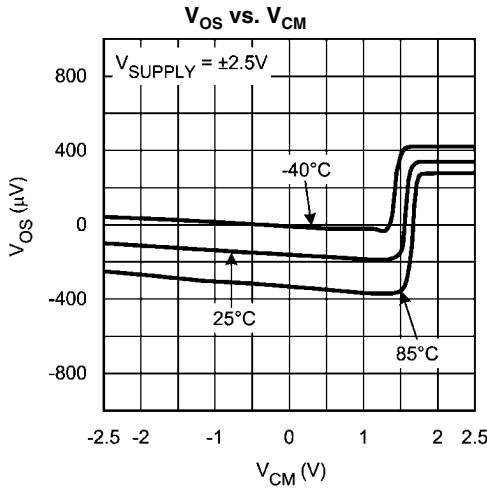

20064030

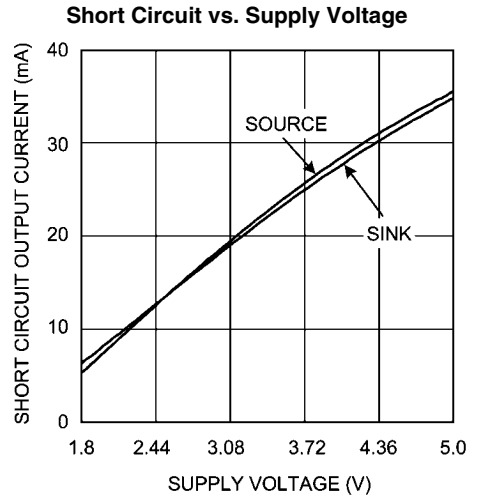

20064001

**Supply Current vs. Supply Voltage (LMV7271)**

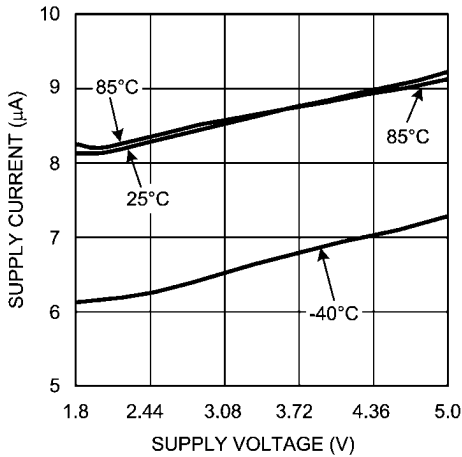

20064002

**Supply Current vs. Supply Voltage (LMV7272)**

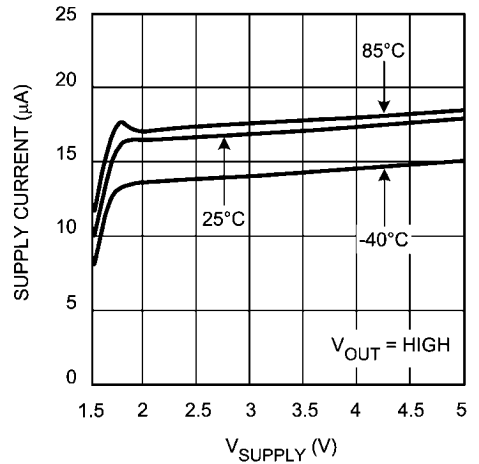

20064031

Supply Current vs. Supply Voltage (LMV7272)

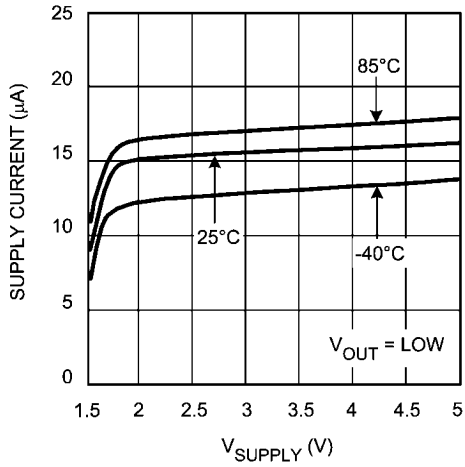

20064032

Output Positive Swing vs. V\_SUPPLY

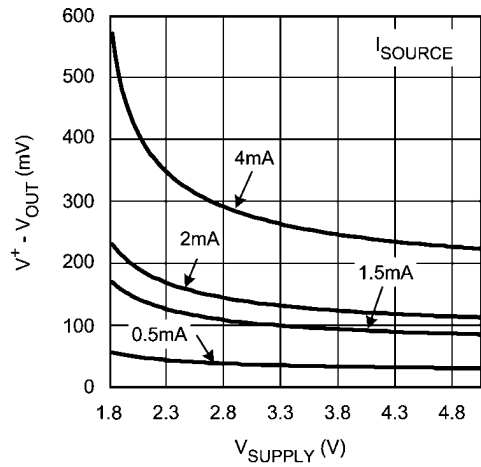

20064033

Output Negative Swing vs. V\_SUPPLY

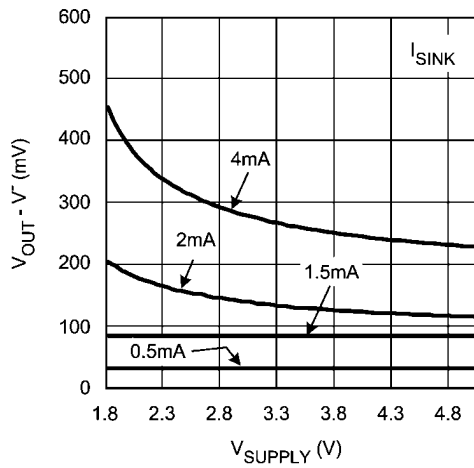

20064034

Output Positive Swing vs. I\_SOURCE

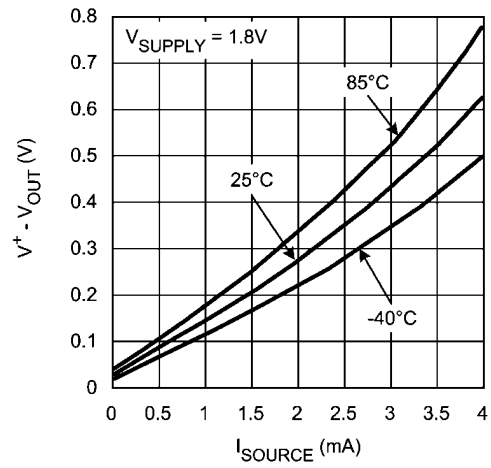

20064035

Output Negative Swing vs. I\_SINK

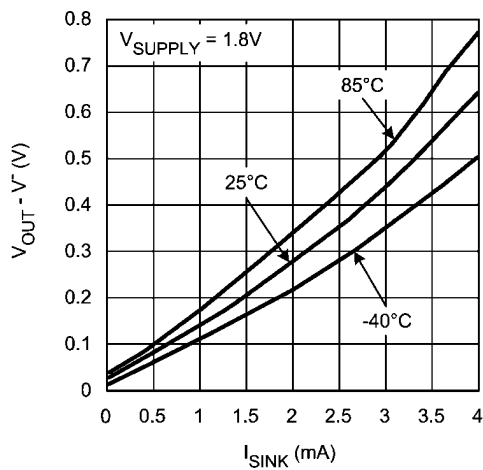

20064036

Output Positive Swing vs. I\_SOURCE

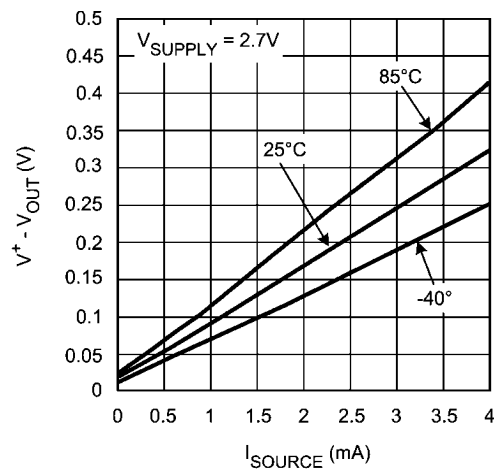

20064037

Output Negative Swing vs.  $I_{SINK}$

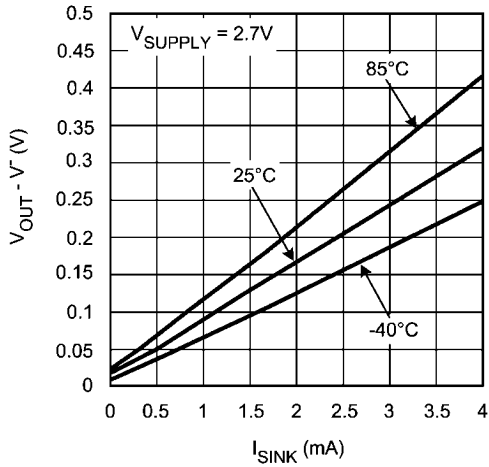

20064038

Output Negative Swing vs.  $I_{SINK}$

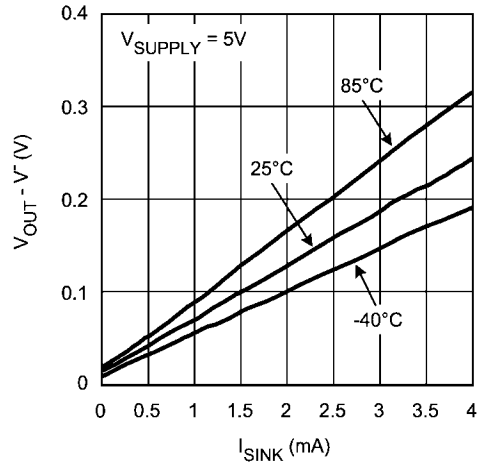

20064039

Output Positive Swing vs.  $I_{SOURCE}$

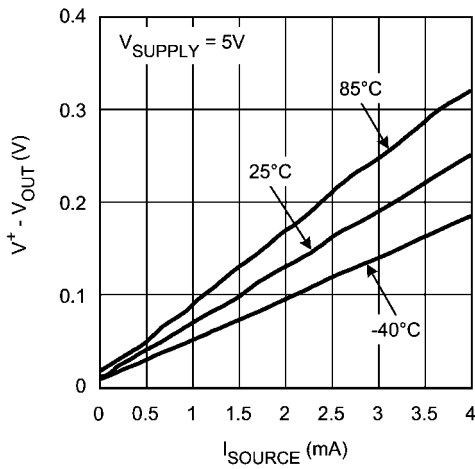

20064040

Propagation Delay ( $t_{PLH}$ )

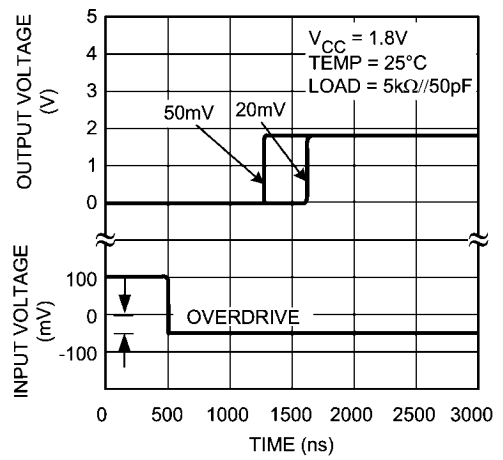

20064014

Propagation Delay ( $t_{PHL}$ )

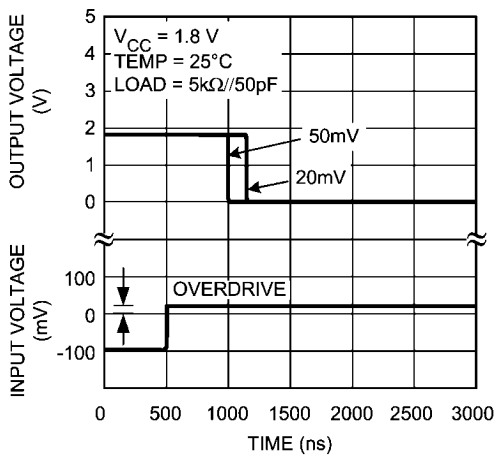

20064018

Propagation Delay ( $t_{PLH}$ )

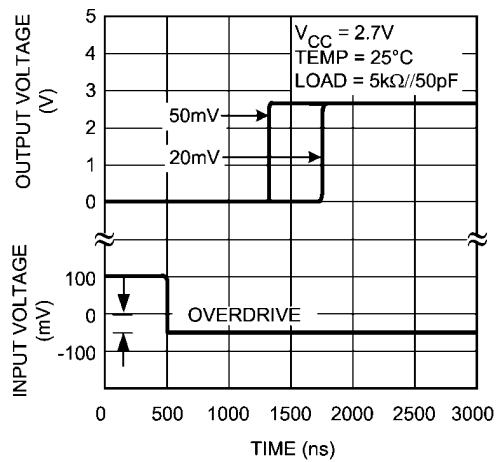

20064015



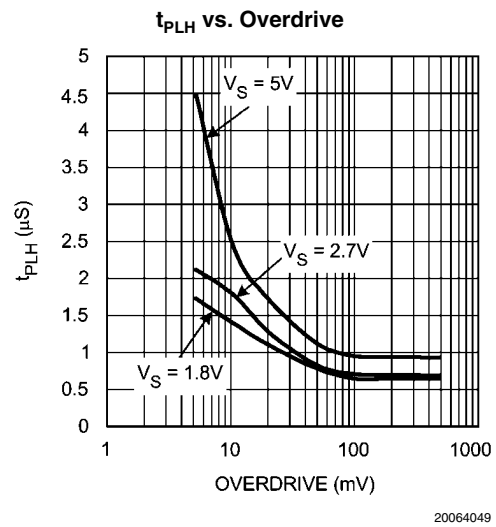
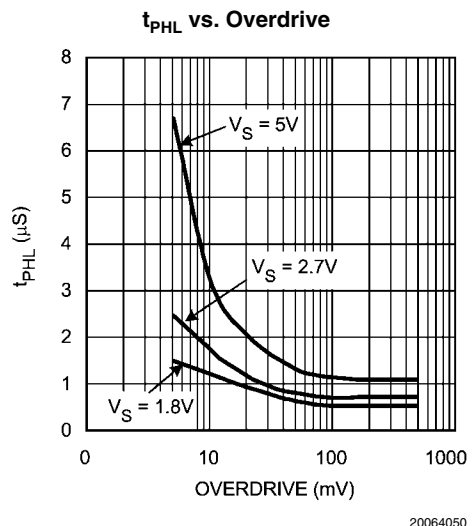
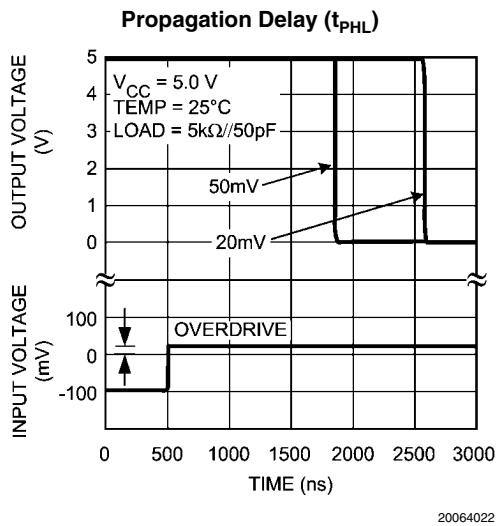
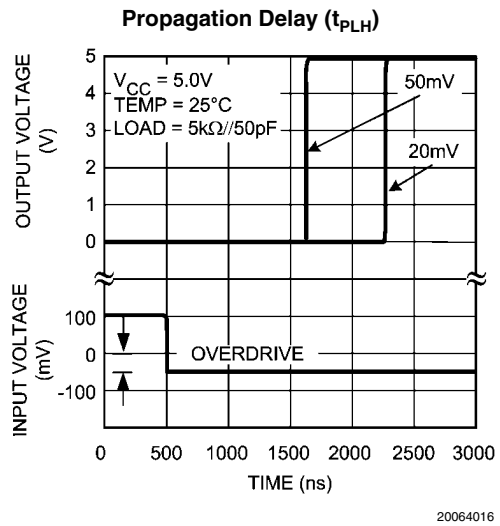
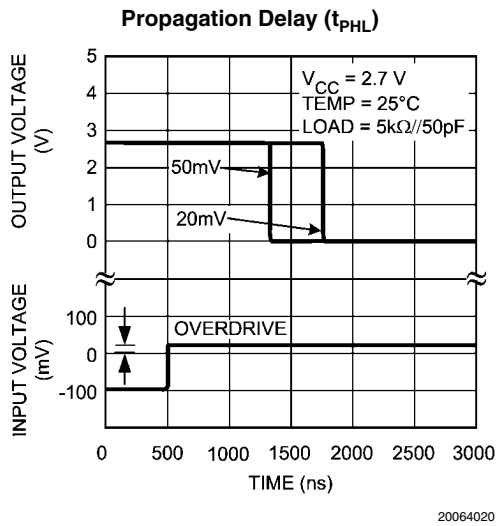

## Application Notes

### BASIC COMPARATOR

A comparator is often used to convert an analog signal to a digital signal. As shown in *Figure 2*, the comparator compares an input voltage ( $V_{IN}$ ) to a reference voltage ( $V_{REF}$ ). If  $V_{IN}$  is

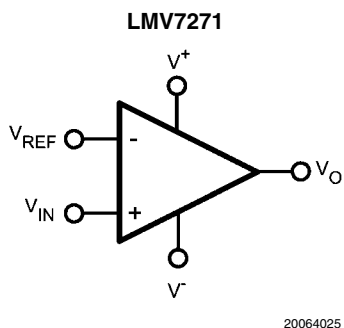

less than  $V_{REF}$ , the output ( $V_O$ ) is low. However, if  $V_{IN}$  is greater than  $V_{REF}$ , the output voltage ( $V_O$ ) is high.

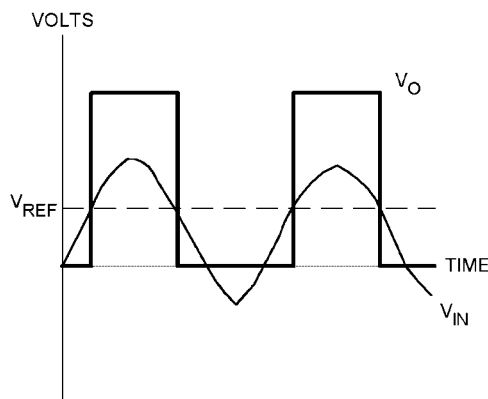

FIGURE 2. LMV7271 Basic Comparator

### RAIL-TO-RAIL INPUT STAGE

The LMV727X has an input common mode voltage range ( $V_{CM}$ ) of  $-0.1V$  below the  $V^-$  to  $0.1V$  above  $V^+$ . This is achieved by using paralleled PNP and NPN differential input pairs. When the  $V_{CM}$  is near  $V^+$ , the NPN pair is on and the PNP pair is off. When the  $V_{CM}$  is near  $V^-$ , the NPN pair is off and the PNP pair is on. The crossover point between the NPN and PNP input stages is around  $950mV$  from  $V^+$ . Since each input stage has its own offset voltage ( $V_{OS}$ ), the  $V_{OS}$  of the comparator becomes a function of the  $V_{CM}$ . See curves for  $V_{OS}$  vs.  $V_{CM}$  in Typical Performance Characteristics section. In application design, it is recommended to keep the  $V_{CM}$  away from the crossover point to avoid problems. The wide input voltage range makes LMV727X ideal in power supply monitoring circuits, where the comparators are used to sense signals close to ground and power supplies.

### OUTPUT STAGE

The LMV7271 and LMV7272 have a push-pull output stage. This output stage keeps the total system power consumption to the absolute minimum. The only current consumed is the low supply current and the current going directly into the load. When the output switches, both PMOS and NMOS at the output stage are on at the same time for a very short time. This allows current to flow directly between  $V^+$  and  $V^-$  through output transistors. The result is a short spike of current (shoot-through current) drawn from the supply and glitches in the supply voltages. The glitches can spread to other parts of the board as noise. To prevent the glitches in supply lines, power supply bypass capacitors must be installed. See section for supply bypassing in the Application Notes for details.

### HYSTERESIS

It is a standard procedure to use hysteresis (positive feedback) around a comparator, to prevent oscillation, and to

avoid excessive noise on the output because the comparator is a good amplifier of its own noise.

### Inverting Comparator with Hysteresis

The inverting comparator with hysteresis requires a three resistor network that is referenced to the supply voltage  $V_{CC}$  of the comparator (*Figure 3*). When  $V_{IN}$  at the inverting input is less than  $V_A$ , the voltage at the non-inverting node of the comparator ( $V_{IN} < V_A$ ), the output voltage is high (for simplicity assume  $V_O$  switches as high as  $V_{CC}$ ). The three network resistors can be represented as  $R_1 || R_3$  in series with  $R_2$ . The lower input trip voltage  $V_{A1}$  is defined as

$$V_{A1} = \frac{V_{CC} R_2}{(R_1 || R_3) + R_2}$$

When  $V_{IN}$  is greater than  $V_A$  ( $V_{IN} > V_A$ ), the output voltage is low and very close to ground. In this case the three network resistors can be presented as  $R_2 || R_3$  in series with  $R_1$ . The upper trip voltage  $V_{A2}$  is defined as

$$V_{A2} = \frac{V_{CC} (R_2 || R_3)}{R_1 + (R_2 || R_3)}$$

The total hysteresis provided by the network is defined as

$$\Delta V_A = V_{A1} - V_{A2}$$

A good typical value of  $\Delta V_A$  would be in the range of 5 to 50mV. This is easily obtained by choosing  $R_3$  as 1000 to 100 times ( $R_1 || R_2$ ) for 5V operation, or as 300 to 30 times ( $R_1 || R_2$ ) for 1.8V operation.

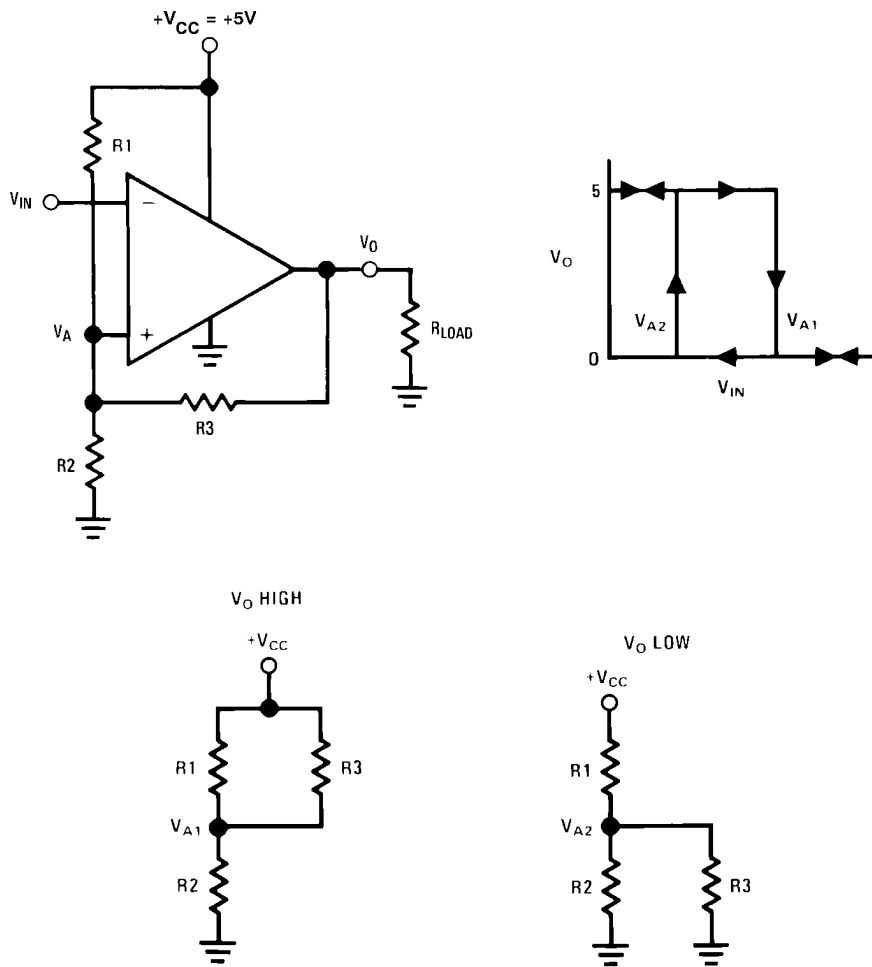

20064042

FIGURE 3. Inverting Comparator with Hysteresis

**Non-Inverting Comparator with Hysteresis**

A non-inverting comparator with hysteresis requires a two-resistor network, and a voltage reference ( $V_{REF}$ ) at the inverting input (Figure 4). When  $V_{IN}$  is low, the output is also low. For the output to switch from low to high,  $V_{IN}$  must rise up to  $V_{IN1}$ , where  $V_{IN1}$  is calculated by

$$V_{in1} = \frac{V_{ref} (R_1 + R_2)}{R_2}$$

When  $V_{IN}$  is high, the output is also high. To make the comparator switch back to its low state,  $V_{IN}$  must equal  $V_{REF}$  before  $V_A$  will again equal  $V_{REF}$ .  $V_{IN}$  can be calculated by:

$$V_{in2} = \frac{V_{ref} (R_1 + R_2) - V_{CC} R_1}{R_2}$$

The hysteresis of this circuit is the difference between  $V_{IN1}$  and  $V_{IN2}$ .

$$\Delta V_{IN} = V_{CC} R_1 / R_2$$

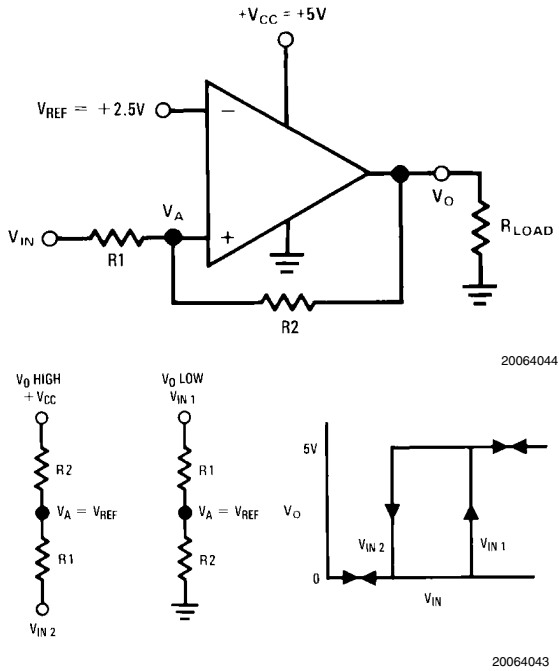

FIGURE 4. Non-Inverting Comparator with Hysteresis

**CIRCUIT TECHNIQUES FOR AVOIDING OSCILLATIONS IN COMPARATOR APPLICATIONS**

Feedback to almost any pin of a comparator can result in oscillation. In addition, when the input signal is a slow voltage ramp or sine wave, the comparator may also burst into oscillation near the crossing point. To avoid oscillation or instability, PCB layout should be engineered thoughtfully. Several precautions are recommended:

1. Power supply bypassing is critical, and will improve stability and transient response. Resistance and inductance from power supply wires and board traces increase power supply line impedance. When supply current changes, the power supply line will move due to its impedance. Large enough supply line shift will cause the comparator to mis-operate. To avoid problems, a small bypass capacitor, such as 0.1µF ceramic, should be placed immediately adjacent to the supply pins. An additional 6.8µF or greater tantalum capacitor should be placed at the point where the power supply for the comparator is introduced onto the board. These capacitors act as an energy reservoir and keep the supply impedance low. In dual supply application, a 0.1µF capacitor is recommended to be placed across V+ and V- pins.
2. Keep all leads short to reduce stray capacitance and lead inductance. It will also minimize any unwanted coupling from any high-level signals (such as the output). The comparators can easily oscillate if the output lead is inadvertently allowed to capacitively couple to the inputs via stray capacitance. This shows up only during the output voltage transition intervals as the comparator changes states. Try to avoid a long loop which could act as an inductor (coil).
3. It is a good practice to use an unbroken ground plane on a printed circuit board to provide all components with a low inductive ground connection. Make sure ground paths are

low-impedance where heavier currents are flowing to avoid ground level shift. Preferably there should be a ground plane under the component.

4. The output trace should be routed away from inputs. The ground plane should extend between the output and inputs to act as a guard. This can be achieved by running a topside ground plane between the output and inputs. A typical PCB layout is shown in Figure 5.

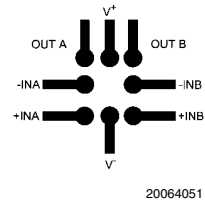

FIGURE 5. Typical PCB Layout

5. When the signal source is applied through a resistive network to one input of the comparator, it is usually advantageous to connect the other input with a resistor with the same value, for both DC and AC consideration. Input traces should be laid out symmetrically if possible.
6. All pins of any unused comparators should be tied to the negative supply.

**micro SMD LIGHT SENSITIVITY**

Exposing the micro SMD device to direct sunlight will cause mis-operation of the device. Light sources such as Halogen lamps can also affect electrical performance if brought near to the device. The wavelengths, which have the most detrimental effect, are reds and infrareds.

**micro SMD MOUNTING**

The micro SMD package requires specific mounting techniques, which are detailed in National Semiconductor Application Note AN-1112.

**LMV7272 micro SMD to DIP Conversion Board**

To facilitate characterization and testing, a micro SMD to DIP conversion board, LMV7272TLCONV, is available. It is a 2-layer board, with the LMV7272 mounted on the bottom layer, and a capacitor (C1, between the positive and negative supplies) added to the top layer.

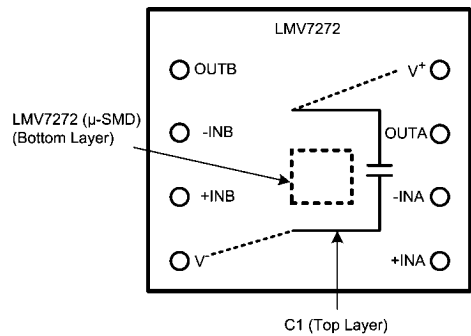

LMV7272TLCONV Diagram

## Typical Applications

### UNIVERSAL LOGIC LEVEL SHIFTER

The output of LMV7275 is an unconnected drain of an NMOS device, which can be pulled up, through a resistor, to any desired output level within the permitted power supply range. Hence, the following simple circuit works as a universal logic level shifter, pulling up the signal to the desired level.

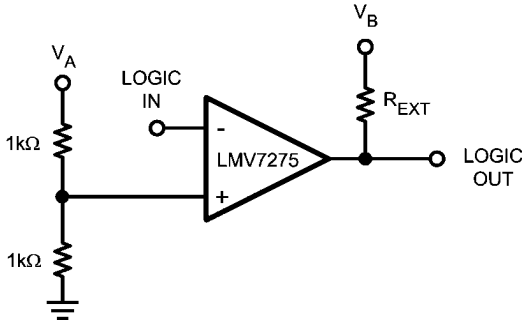

20064052

FIGURE 6. Logic Level Shifter

### POSITIVE PEAK DETECTOR

A positive peak detect circuit is basically a comparator operated in a unity gain follower configuration, with a capacitor as a load to maintain the highest voltage. A diode is added at the output to prevent the capacitor from discharging through the pull-up resistor, and a 1MΩ resistor added in parallel to the capacitor to provide a high impedance discharge path. When the input  $V_{IN}$  increases, the inverting input of the comparator follows it, thus charging the capacitor. When it decreases, the cap discharges through the 1MΩ resistor. The decay time can be modified by changing the resistor. The output should be accessed through a follower circuit to prevent loading.

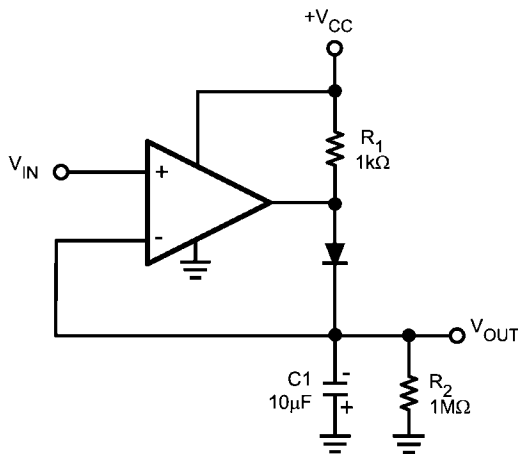

20064054

FIGURE 7. Positive Peak Detector

### OR'ING THE OUTPUT

Since the output is an unconnected NMOS drain, many drains can be tied together, pulled up to  $V_{DD}$  by a single resistor to provide an output OR'ing function. If any of the comparator outputs is pulled low the output  $V_O$  goes down.

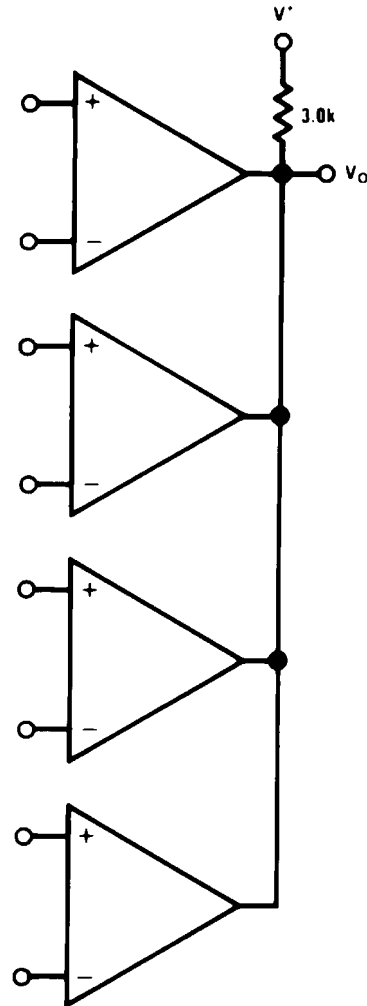

20064053

FIGURE 8. OR'ing the Outputs

**NEGATIVE PEAK DETECTOR**

For the negative detector, the output transistor of the comparator acts as a low impedance current sink. Since there is no pull-up resistor, the only discharge path will be the 1MΩ resistor and any load impedance used. Decay time is changed by varying the 1MΩ resistor.

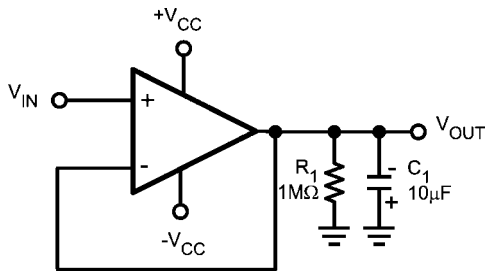

20064055

**FIGURE 9. Negative Peak Detector**

**SQUARE WAVE GENERATOR**

A typical application for a comparator is as a square wave oscillator. The circuit below generates a square wave whose period is set by the RC time constant of the capacitor C<sub>1</sub> and resistor R<sub>4</sub>. The maximum frequency is limited by the large signal propagation delay of the comparator, and by the capacitive loading at the output, which limits the output slew rate.

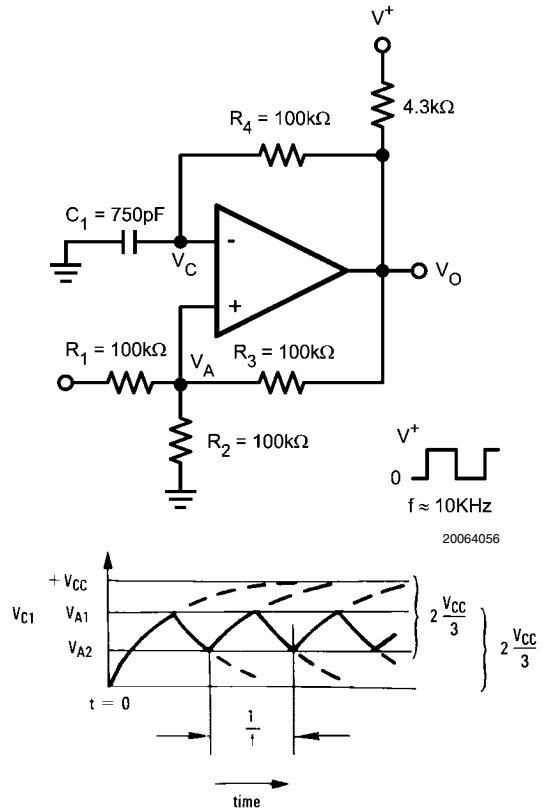

20064056

20064057

**FIGURE 10. Squarewave Oscillator**

To analyze the circuit, consider it when the output is high. That implies that the inverted input (V<sub>C</sub>) is lower than the non-inverting input (V<sub>A</sub>). This causes the C<sub>1</sub> to get charged through R<sub>4</sub>, and the voltage V<sub>C</sub> increases till it is equal to the non-inverting input. The value of V<sub>A</sub> at this point is

$$V_{A1} = \frac{V_{CC} \cdot R_2}{R_2 + R_1 \parallel R_3}$$

If R<sub>1</sub> = R<sub>2</sub> = R<sub>3</sub> then V<sub>A1</sub> = 2V<sub>CC</sub>/3

At this point the comparator switches pulling down the output to the negative rail. The value of V<sub>A</sub> at this point is

$$V_{A2} = \frac{V_{CC} (R_2 \parallel R_3)}{R_1 + (R_2 \parallel R_3)}$$

If R<sub>1</sub> = R<sub>2</sub> = R<sub>3</sub> then V<sub>A2</sub> = V<sub>CC</sub>/3

The capacitor C<sub>1</sub> now discharges through R<sub>4</sub>, and the voltage V<sub>C</sub> decreases till it is equal to V<sub>A2</sub>, at which point the comparator switches again, bringing it back to the initial stage. The time period is equal to twice the time it takes to discharge C<sub>1</sub> from 2V<sub>CC</sub>/3 to V<sub>CC</sub>/3, which is given by R<sub>4</sub>C<sub>1</sub>·ln2. Hence the formula for the frequency is:

$$F = 1/(2 \cdot R_4 \cdot C_1 \cdot \ln 2)$$

**Physical Dimensions** inches (millimeters) unless otherwise noted

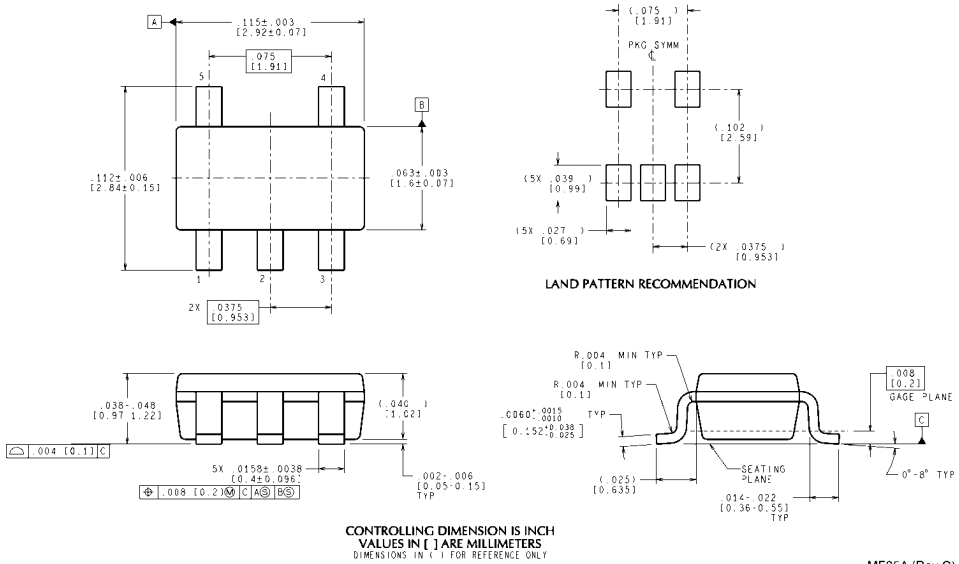

**5-Pin SOT-23**  
NS Package Number MF05A

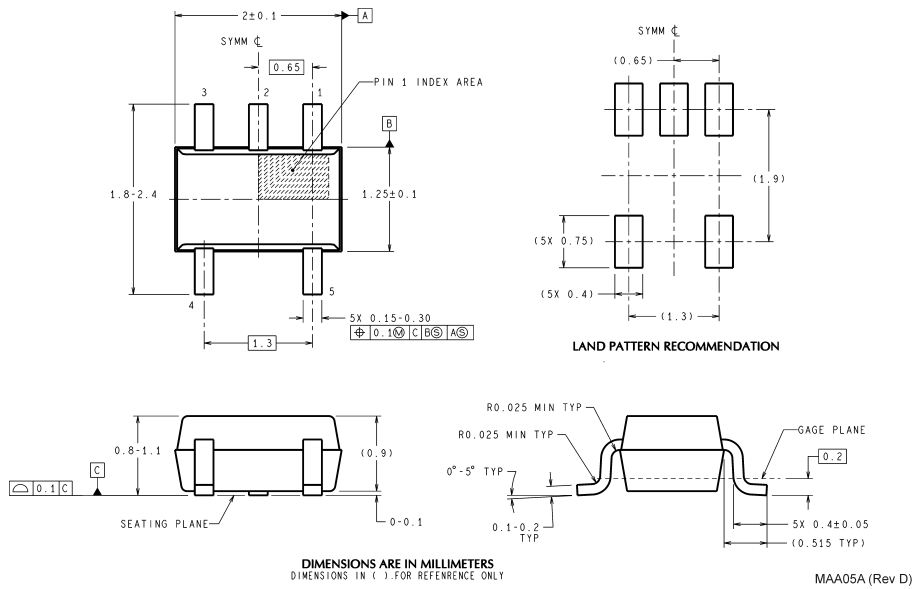

**5-Pin SC-70**  
NS Package Number MAA05A

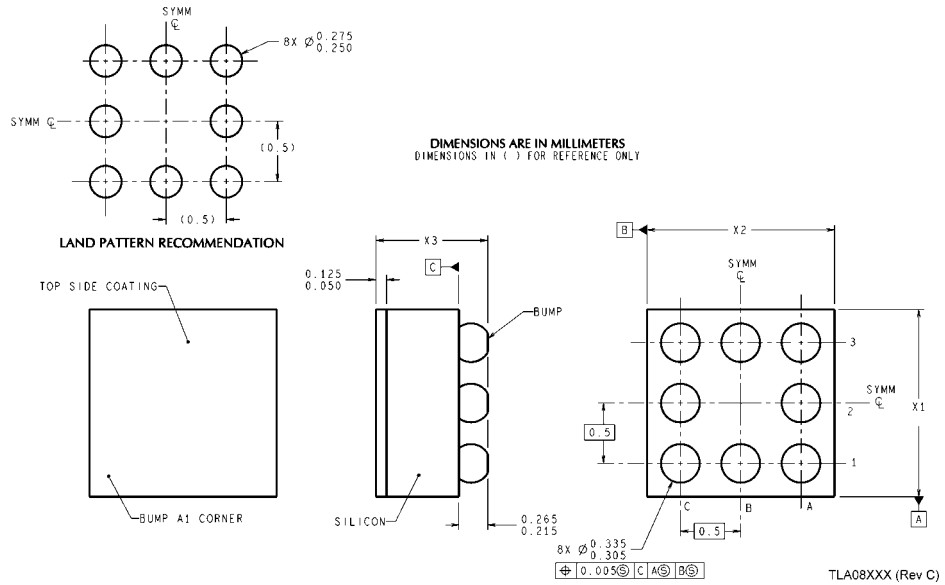

NOTE: UNLESS OTHERWISE SPECIFIED

1. EPOXY COATING
2. 63Sn/37Pb EUTECTIC BUMP
3. RECOMMEND NON-SOLDER MASK DEFINED LANDING PAD.
4. PIN A1 IS ESTABLISHED BY LOWER LEFT CORNER WITH RESPECT TO TEXT ORIENTATION REMAINING PINS ARE NUMBERED COUNTERCLOCKWISE.
5. XXX IN DRAWING NUMBER REPRESENTS PACKAGE SIZE VARIATION WHERE X1 IS PACKAGE WIDTH, X2 IS PACKAGE LENGTH AND X3 IS PACKAGE HEIGHT.
6. REFERENCE JEDEC REGISTRATION MO-211, VARIATION BC.

**8-Bump micro SMD**  
**NS Package Number TLA08AAA**  
**X1 = 1.514mm X2 = 1.514mm X3 = 0.600mm**



# Notes

## Notes

For more National Semiconductor product information and proven design tools, visit the following Web sites at:

Products		Design Support	
Amplifiers	<a href="http://www.national.com/amplifiers">www.national.com/amplifiers</a>	WEBENCH	<a href="http://www.national.com/webench">www.national.com/webench</a>
Audio	<a href="http://www.national.com/audio">www.national.com/audio</a>	Analog University	<a href="http://www.national.com/AU">www.national.com/AU</a>
Clock Conditioners	<a href="http://www.national.com/timing">www.national.com/timing</a>	App Notes	<a href="http://www.national.com/appnotes">www.national.com/appnotes</a>
Data Converters	<a href="http://www.national.com/adc">www.national.com/adc</a>	Distributors	<a href="http://www.national.com/contacts">www.national.com/contacts</a>
Displays	<a href="http://www.national.com/displays">www.national.com/displays</a>	Green Compliance	<a href="http://www.national.com/quality/green">www.national.com/quality/green</a>
Ethernet	<a href="http://www.national.com/ethernet">www.national.com/ethernet</a>	Packaging	<a href="http://www.national.com/packaging">www.national.com/packaging</a>
Interface	<a href="http://www.national.com/interface">www.national.com/interface</a>	Quality and Reliability	<a href="http://www.national.com/quality">www.national.com/quality</a>
LVDS	<a href="http://www.national.com/lvds">www.national.com/lvds</a>	Reference Designs	<a href="http://www.national.com/refdesigns">www.national.com/refdesigns</a>
Power Management	<a href="http://www.national.com/power">www.national.com/power</a>	Feedback	<a href="http://www.national.com/feedback">www.national.com/feedback</a>
Switching Regulators	<a href="http://www.national.com/switchers">www.national.com/switchers</a>		
LDOs	<a href="http://www.national.com/ldo">www.national.com/ldo</a>		
LED Lighting	<a href="http://www.national.com/led">www.national.com/led</a>		
PowerWise	<a href="http://www.national.com/powerwise">www.national.com/powerwise</a>		
Serial Digital Interface (SDI)	<a href="http://www.national.com/sdi">www.national.com/sdi</a>		
Temperature Sensors	<a href="http://www.national.com/tempsensors">www.national.com/tempsensors</a>		
Wireless (PLL/VCO)	<a href="http://www.national.com/wireless">www.national.com/wireless</a>		

THE CONTENTS OF THIS DOCUMENT ARE PROVIDED IN CONNECTION WITH NATIONAL SEMICONDUCTOR CORPORATION ("NATIONAL") PRODUCTS. NATIONAL MAKES NO REPRESENTATIONS OR WARRANTIES WITH RESPECT TO THE ACCURACY OR COMPLETENESS OF THE CONTENTS OF THIS PUBLICATION AND RESERVES THE RIGHT TO MAKE CHANGES TO SPECIFICATIONS AND PRODUCT DESCRIPTIONS AT ANY TIME WITHOUT NOTICE. NO LICENSE, WHETHER EXPRESS, IMPLIED, ARISING BY ESTOPPEL OR OTHERWISE, TO ANY INTELLECTUAL PROPERTY RIGHTS IS GRANTED BY THIS DOCUMENT.

TESTING AND OTHER QUALITY CONTROLS ARE USED TO THE EXTENT NATIONAL DEEMS NECESSARY TO SUPPORT NATIONAL'S PRODUCT WARRANTY. EXCEPT WHERE MANDATED BY GOVERNMENT REQUIREMENTS, TESTING OF ALL PARAMETERS OF EACH PRODUCT IS NOT NECESSARILY PERFORMED. NATIONAL ASSUMES NO LIABILITY FOR APPLICATIONS ASSISTANCE OR BUYER PRODUCT DESIGN. BUYERS ARE RESPONSIBLE FOR THEIR PRODUCTS AND APPLICATIONS USING NATIONAL COMPONENTS. PRIOR TO USING OR DISTRIBUTING ANY PRODUCTS THAT INCLUDE NATIONAL COMPONENTS, BUYERS SHOULD PROVIDE ADEQUATE DESIGN, TESTING AND OPERATING SAFEGUARDS.

EXCEPT AS PROVIDED IN NATIONAL'S TERMS AND CONDITIONS OF SALE FOR SUCH PRODUCTS, NATIONAL ASSUMES NO LIABILITY WHATSOEVER, AND NATIONAL DISCLAIMS ANY EXPRESS OR IMPLIED WARRANTY RELATING TO THE SALE AND/OR USE OF NATIONAL PRODUCTS INCLUDING LIABILITY OR WARRANTIES RELATING TO FITNESS FOR A PARTICULAR PURPOSE, MERCHANTABILITY, OR INFRINGEMENT OF ANY PATENT, COPYRIGHT OR OTHER INTELLECTUAL PROPERTY RIGHT.

### LIFE SUPPORT POLICY

**NATIONAL'S PRODUCTS ARE NOT AUTHORIZED FOR USE AS CRITICAL COMPONENTS IN LIFE SUPPORT DEVICES OR SYSTEMS WITHOUT THE EXPRESS PRIOR WRITTEN APPROVAL OF THE CHIEF EXECUTIVE OFFICER AND GENERAL COUNSEL OF NATIONAL SEMICONDUCTOR CORPORATION.** As used herein:

Life support devices or systems are devices which (a) are intended for surgical implant into the body, or (b) support or sustain life and whose failure to perform when properly used in accordance with instructions for use provided in the labeling can be reasonably expected to result in a significant injury to the user. A critical component is any component in a life support device or system whose failure to perform can be reasonably expected to cause the failure of the life support device or system or to affect its safety or effectiveness.

National Semiconductor and the National Semiconductor logo are registered trademarks of National Semiconductor Corporation. All other brand or product names may be trademarks or registered trademarks of their respective holders.

Copyright© 2008 National Semiconductor Corporation

For the most current product information visit us at [www.national.com](http://www.national.com)



**National Semiconductor  
Americas Technical  
Support Center**  
Email: [support@nsc.com](mailto:support@nsc.com)  
Tel: 1-800-272-9959

**National Semiconductor Europe  
Technical Support Center**  
Email: [europe.support@nsc.com](mailto:europe.support@nsc.com)  
German Tel: +49 (0) 180 5010 771  
English Tel: +44 (0) 870 850 4288

**National Semiconductor Asia  
Pacific Technical Support Center**  
Email: [ap.support@nsc.com](mailto:ap.support@nsc.com)

**National Semiconductor Japan  
Technical Support Center**  
Email: [jpn.feedback@nsc.com](mailto:jpn.feedback@nsc.com)