

## LMH6553 900 MHz Fully Differential Amplifier With Output Limiting Clamp

Check for Samples: [LMH6553](#)

### FEATURES

- 900 MHz –3 dB Small Signal Bandwidth @  $A_V = 1$
- 670 MHz –3 dB Large Signal Bandwidth @  $A_V = 1$
- –79 dB THD @ 20 MHz
- –92 dB IMD3 @  $f_c = 20$  MHz
- 10 ns Settling Time to 0.1%
- 600 ps Clamp Overdrive Recovery Time
- 40 mV Clamp Accuracy with 100% Overdrive
- –0.1 mV/°C Clamp Temperature Drift
- 4.5 to 12 Supply Voltage Operation

### APPLICATIONS

- Differential ADC Driver
- Video Over Twisted Pair
- Differential Line Driver
- Single End to Differential Converter
- High Speed Differential Signaling
- IF/RF Amplifier
- SAW Filter Buffer/Driver
- CCD Output Limiting Amplifier
- Automotive Safety Applications

### DESCRIPTION

The LMH6553 is a 900 MHz differential amplifier with an integrated adjustable output limiting clamp. The clamp increases system performance and provides transient over-voltage protection to following stages. The internal clamp feature of the LMH6553 reduces or eliminates the need for external discrete overload protection networks. When used to drive ADCs, the amplifier's output clamp allows low voltage ADC inputs to be protected from being overdriven and damaged by large input signals appearing at the system input. Fast overdrive recovery of 600 ps ensures the amplifier output rapidly recovers from a clamping event and quickly resumes to follow the input signal. The LMH6553 delivers exceptional bandwidth, distortion, and noise performance ideal for driving ADCs up to 14-bits. The LMH6553 could also be used for automotive, communication, medical, test and measurement, video, and LIDAR applications.

With external gain set resistors and integrated common mode feedback, the LMH6553 can be configured as either a differential input to differential output or single ended input to differential output gain block. The LMH6553 can be AC or DC coupled at the input which makes it suitable for a wide range of applications including communication systems and high speed oscilloscope front ends. The LMH6553 is available in 8-pin SO PowerPAD and 8-pin WSON packages, and is part of our LMH™ high speed amplifier family.

### Typical Application

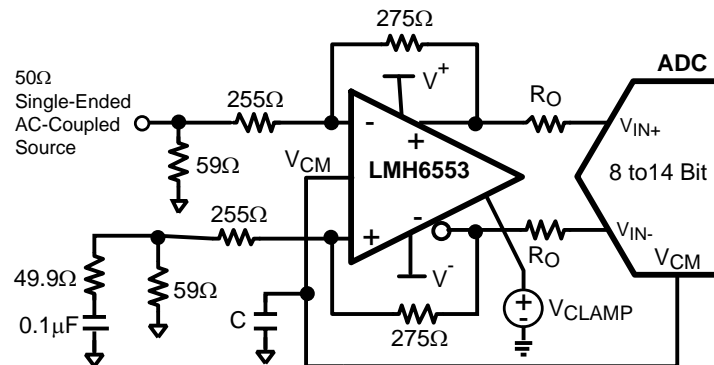

Figure 1. Single-Ended Input Differential Output ADC Driver



Please be aware that an important notice concerning availability, standard warranty, and use in critical applications of Texas Instruments semiconductor products and disclaimers thereto appears at the end of this data sheet.

LMH is a trademark of Texas Instruments.

All other trademarks are the property of their respective owners.



These devices have limited built-in ESD protection. The leads should be shorted together or the device placed in conductive foam during storage or handling to prevent electrostatic damage to the MOS gates.

### Absolute Maximum Ratings <sup>(1)(2)</sup>

ESD Tolerance <sup>(3)</sup>	
Human Body Model	4000V
Machine Model	350V
Supply Voltage	13.2V
Common Mode Input Voltage	$\pm V_S$
Maximum Input Current (pins 1, 2, 7, 8)	30 mA
Maximum Output Current (pins 4, 5)	<sup>(4)</sup>
Maximum Junction Temperature	150°C
For soldering specifications see product folder at <a href="http://www.ti.com">http://www.ti.com</a> and <a href="http://www.ti.com/lit/SNOA549">http://www.ti.com/lit/SNOA549</a>	

- (1) Absolute Maximum Ratings indicate limits beyond which damage to the device may occur. Operating Ratings indicate conditions for which the device is intended to be functional, but specific performance is not ensured. For ensured specifications, see the Electrical Characteristics tables.
- (2) If Military/Aerospace specified devices are required, please contact the Texas Instruments Sales Office/ Distributors for availability and specifications.
- (3) Human Body Model, applicable std. MIL-STD-883, Method 30157. Machine Model, applicable std. JESD22-A115-A (ESD MM std. of JEDEC). Field-Induced Charge-Device Model, applicable std. JESD22-C101-C (ESD FICDM std. of JEDEC).
- (4) The maximum output current ( $I_{OUT}$ ) is determined by device power dissipation limitations. See [POWER DISSIPATION](#) of [Application Information](#) for more details.

### Operating Ratings <sup>(1)</sup>

Operating Temperature Range <sup>(2)</sup>	-40°C to +125°C
Storage Temperature Range	-65°C to +150°C
Total Supply Voltage	4.5V to 12V
Package Thermal Resistance ( $\theta_{JA}$ )	
8-Pin SO PowerPAD	59°C/W
8-Pin WSON	58°C/W

- (1) Absolute Maximum Ratings indicate limits beyond which damage to the device may occur. Operating Ratings indicate conditions for which the device is intended to be functional, but specific performance is not ensured. For ensured specifications, see the Electrical Characteristics tables.
- (2) The maximum power dissipation is a function of  $T_{J(MAX)}$ ,  $\theta_{JA}$ . The maximum allowable power dissipation at any ambient temperature is  $P_D = (T_{J(MAX)} - T_A) / \theta_{JA}$ . All numbers apply for packages soldered directly onto a PC Board.

**$V_S = \pm 5V$  Electrical Characteristics <sup>(1)</sup>**

Unless otherwise specified, all limits are ensured for  $T_A = 25^\circ C$ ,  $V_S = \pm 5V$ ,  $A_V = 1$ ,  $V_{CM} = 0V$ ,  $V_{CLAMP} = 3V$ ,  $R_F = R_G = 275\Omega$ ,  $R_L = 200\Omega$ , for single-ended in, differential out. **Boldface** limits apply at the temperature extremes.

Symbol	Parameter	Conditions	Min <sup>(2)</sup>	Typ <sup>(3)</sup>	Max <sup>(2)</sup>	Units
<b>AC Performance (Differential)</b>						
SSBW	Small Signal -3 dB Bandwidth <sup>(2)</sup>	$V_{OUT} = 0.2 V_{PP}$ , $A_V = 1$ , $R_L = 1 k\Omega$		900		MHz
		$V_{OUT} = 0.2 V_{PP}$ , $A_V = 1$		720		
		$V_{OUT} = 0.2 V_{PP}$ , $A_V = 2$		680		
		$V_{OUT} = 0.2 V_{PP}$ , $A_V = 4$		630		
		$V_{OUT} = 0.2 V_{PP}$ , $A_V = 8$ , ( $R_F = 400\Omega$ , $R_G = 50\Omega$ )		350		
LSBW	Large Signal -3 dB Bandwidth	$V_{OUT} = 2 V_{PP}$ , $A_V = 1$ , $R_L = 1 k\Omega$		670		MHz
		$V_{OUT} = 2 V_{PP}$ , $A_V = 1$		540		
		$V_{OUT} = 2 V_{PP}$ , $A_V = 2$		530		
		$V_{OUT} = 2 V_{PP}$ , $A_V = 4$		490		
		$V_{OUT} = 2 V_{PP}$ , $A_V = 8$ , ( $R_F = 400\Omega$ , $R_G = 50\Omega$ )		350		
	0.1 dB Bandwidth	$V_{OUT} = 0.2 V_{PP}$ , $A_V = 1$		50		MHz
	0.5 dB Bandwidth	$V_{OUT} = 0.2 V_{PP}$ , $A_V = 1$		525		MHz
	Slew Rate	4V Step, $A_V = 1$		2300		V/ $\mu$ s
	Rise/Fall Time, 10%-90%	2V Step		690		ps
	0.1% Settling Time	2V Step		10		ns
	1.0% Settling Time	2V Step		6		ns
<b>Distortion and Noise Response</b>						
HD2	2 <sup>nd</sup> Harmonic Distortion	$V_{OUT} = 2 V_{PP}$ , $f = 20$ MHz, $R_L = 800\Omega$		-79		dBc
		$V_{OUT} = 2 V_{PP}$ , $f = 70$ MHz, $R_L = 800\Omega$		-78		
HD3	3 <sup>rd</sup> Harmonic Distortion	$V_{OUT} = 2 V_{PP}$ , $f = 20$ MHz, $R_L = 800\Omega$		-90		dBc
		$V_{OUT} = 2 V_{PP}$ , $f = 70$ MHz, $R_L = 800\Omega$		-71		
IMD3	3rd-Order Two-Tone Intermodulation	$f_c = 20$ MHz, $V_{OUT} = 2 V_{PP}$ Composite, $R_L = 200\Omega$		-92		dBc
		$f_c = 150$ MHz, $V_{OUT} = 2 V_{PP}$ Composite, $R_L = 200\Omega$		-76		
	Input Noise Voltage	$f = 100$ kHz		1.2		nV/ $\sqrt{Hz}$
	Input Noise Current	$f = 100$ kHz		13.6		pA/ $\sqrt{Hz}$
	Noise Figure (See <a href="#">Figure 58</a> )	50 $\Omega$ System, $A_V = 9$ , 10 MHz		10.3		dB
<b>Input Characteristics</b>						
$I_{BI}$	Input Bias Current <sup>(4)</sup>		-95	50	95	$\mu$ A
$I_{Boffset}$	Input Bias Current Differential <sup>(3)</sup>	$V_{CM} = 0V$ , $V_{ID} = 0V$ , $I_{Boffset} = (I_{B^-} - I_{B^+})/2$	-18	2.5	18	$\mu$ A
CMRR	Common Mode Rejection Ratio <sup>(3)</sup>	DC, $V_{CM} = 0V$ , $V_{ID} = 0V$		82		dBc
$R_{IN}$	Input Resistance	Differential		15		$\Omega$
$C_{IN}$	Input Capacitance	Differential		0.5		pF
CMVR	Input Common Mode Voltage Range	CMRR > 38 dB	$\pm 3.3$	$\pm 3.6$		V

- (1) Electrical Table values apply only for factory testing conditions at the temperature indicated. Factory testing conditions result in very limited self-heating of the device such that  $T_J = T_A$ . No specification of parametric performance is indicated in the electrical tables under conditions of internal self-heating where  $T_J > T_A$ . See [Application Information](#) for information on temperature de-rating of this device." Min/Max ratings are based on product characterization and simulation. Individual parameters are tested as noted.
- (2) Limits are 100% production tested at 25°C. Limits over the operating temperature range are specified through correlation using Statistical Quality Control (SQC) methods.
- (3) Typical values represent the most likely parametric norm as determined at the time of characterization. Actual typical values may vary over time and will also depend on the application and configuration. The typical values are not tested and are not ensured on shipped production material.
- (4) Exceeding limits could result in excessive device current.

### $V_S = \pm 5V$ Electrical Characteristics <sup>(1)</sup> (continued)

Unless otherwise specified, all limits are ensured for  $T_A = 25^\circ\text{C}$ ,  $V_S = \pm 5V$ ,  $A_V = 1$ ,  $V_{CM} = 0V$ ,  $V_{CLAMP} = 3V$ ,  $R_F = R_G = 275\Omega$ ,  $R_L = 200\Omega$ , for single-ended in, differential out. **Boldface** limits apply at the temperature extremes.

Symbol	Parameter	Conditions	Min <sup>(2)</sup>	Typ <sup>(3)</sup>	Max <sup>(2)</sup>	Units
<b>Output Performance</b>						
	Output Voltage Level <sup>(5)</sup>	Single-Ended Output	-3.7	$\pm 3.78$	+3.7	V
$I_{OUT}$	Linear Output Current <sup>(5)</sup>	$V_{OUT} = 0V$	$\pm 100$	$\pm 120$		mA
$I_{SC}$	Short Circuit Current	One Output Shorted to Ground $V_{IN} = 2V$ Single-Ended <sup>(6)</sup>		$\pm 150$		mA
<b>Clamp Performance</b>						
$V_{CLAMP}$	$V_{CLAMP}$ Voltage Range	Continuous Operation <sup>(7)</sup>	$V_{CM}$		$V_{CM} + 2.0$	V
	$V_{CLAMP}$ Peak Voltage	<sup>(8)</sup>			$V_{CM} + 3.0$	
	Default $V_{CLAMP}$ Voltage	$V_{CLAMP}$ Floating	0.92	1.0	1.08	V
	Upper Clamp Level Accuracy	$V_{CLAMP} = 2V$ , $V_{CM} = 1.5V$ , $V_O = 2V$ , 100% Overdrive	-53	-40	+53	mV
	Lower Clamp Level Accuracy	$V_{CLAMP} = 2V$ , $V_{CM} = 1.5V$ , $V_O = 1V$ , 100% Overdrive	-30	-8	+30	
	Clamp Accuracy Temperature Drift			-0.1		mV/ $^\circ\text{C}$
	Clamp Pin Bias Current	$V_{IN} = 0V$ , $V_{CLAMP(MIN)} = -3.1V$	-200	-175		$\mu\text{A}$
		$V_{IN} = 0V$ , $V_{CLAMP(MAX)} = +4.5V$		150	175	
	Clamp Pin Bias Drift			0.3		$\mu\text{A}/^\circ\text{C}$
	Diff Amp Input Bias Shift	Linear to Clamped Operation		60		$\mu\text{A}$
	Clamp Pin Input Impedance			30 1		K $\Omega$ /pF
	Clamp Pin Feedthrough	$f = 10\text{ MHz}$		-60		dB
	Clamp Bandwidth	$0.5V_{DC} + 40\text{ mV}_{PP}$ , SE $V_{IN} = 2V$		140		MHz
	Clamp Slew Rate	100% Overdrive		64		V/ $\mu\text{s}$
	Clamp Overshoot	$V_{IN} = 2V$ Step, $A_V = 2\text{ V/V}$ , $V_{CLAMP} = 0.5V$ , $V_{CM} = 0V$ , 100% Overdrive		125		mV
	Clamp Overshoot	$V_{IN} = 2V$ Step, $A_V = 2\text{ V/V}$ , $V_{CLAMP} = 2V$ , $V_{CM} = 1.5V$ , 100% Overdrive		250		mV
	Clamp Overshoot Width	<sup>(9)</sup>		650		ps
	Clamp Overdrive Recovery Time	$V_{IN} = 2V$ Step, $A_V = 2\text{ V/V}$ , $V_{CLAMP} = 0.5V$ , $V_{CM} = 0V$ , 50% Output Crossing		600		ps
	Linearity Guardband <sup>(10)</sup>	$f = 75\text{ MHz}$ , $V_{OD} = 2\text{ V}_{PP}$ , $R_L = 800$ , SFDR Down 3 dB		22		mV
<b>Output Common Mode Control Circuit</b>						
	Common Mode Small Signal Bandwidth	$V_{IN^+} = V_{IN^-} = 0$		220		MHz
	Slew Rate	$V_{IN^+} = V_{IN^-} = 0$		340		V/ $\mu\text{s}$
$V_{OSCM}$	Output Common Mode Error	Common Mode, $V_{IN} = \text{Float}$ , $V_{CM} = 0$	-25	1	25	mV

- (5) Typical values represent the most likely parametric norm as determined at the time of characterization. Actual typical values may vary over time and will also depend on the application and configuration. The typical values are not tested and are not ensured on shipped production material.
- (6) Short circuit current should be limited in duration to no more than 10 seconds. See [POWER DISSIPATION](#) in [Application Information](#) for more details.
- (7) Exceeding limits could result in excessive device current.
- (8) This parameter is ensured by design and/or characterization and is not tested in production. The condition of  $V_{CLAMP} = 3V$  is not intended for continuous operation; continuous operation with  $V_{CLAMP} = 3V$  may incur permanent damage to the device.
- (9) Clamp Overshoot Width is the duration of overshoot in a 100% overdrive condition.
- (10) Linearity Guardband is defined for an output sinusoid ( $f = 75\text{ MHz}$ ,  $V_{OD} = 2\text{ V}_{PP}$ ). It is the difference between the  $V_{CLAMP}$  level and the peak output voltage where the SFDR is decreased by 3 dB.

**$V_S = \pm 5V$  Electrical Characteristics <sup>(1)</sup> (continued)**

Unless otherwise specified, all limits are ensured for  $T_A = 25^\circ C$ ,  $V_S = \pm 5V$ ,  $A_V = 1$ ,  $V_{CM} = 0V$ ,  $V_{CLAMP} = 3V$ ,  $R_F = R_G = 275\Omega$ ,  $R_L = 200\Omega$ , for single-ended in, differential out. **Boldface** limits apply at the temperature extremes.

Symbol	Parameter	Conditions	Min <sup>(2)</sup>	Typ <sup>(3)</sup>	Max <sup>(2)</sup>	Units
	Input Bias Current	$V_{CM(TYPICAL)} = 0$ , <sup>(11)</sup>	-8	-3.5	1	$\mu A$
		$V_{CM(MIN)} = -3.2V$ , <sup>(11)</sup>	-9	-4.5		
		$V_{CM(MAX)} = +3.2V$ , <sup>(11)</sup>		-2.5	2	
	Voltage Range		$\pm 3.14$	$\pm 3.18$		V
	CMRR	Measure $V_{OD}$ , $V_{ID} = 0V$		80		dB
	Input Resistance			200		k $\Omega$
	Gain	$\Delta V_{O,CM}/\Delta V_{CM}$	0.995	1.00	1.008	V/V
<b>Miscellaneous Performance</b>						
$Z_T$	Open Loop Transimpedance	Differential		112		dB $\Omega$
PSRR	Power Supply Rejection Ratio	DC, $\Delta V_S = \pm 1V$		87		dB
$I_S$	Supply Current	$R_L = \infty$	25	29.1	<b>33</b> <b>37</b>	mA

(11) Negative current implies current flowing out of the device.

 **$V_S = \pm 2.5V$  Electrical Characteristics <sup>(1)</sup>**

Unless otherwise specified, all limits are ensured for  $T_A = 25^\circ C$ ,  $V_S = \pm 2.5V$ ,  $A_V = 1$ ,  $V_{CM} = 0V$ ,  $V_{CLAMP} = 2V$ ,  $R_F = R_G = 275\Omega$ ,  $R_L = 200\Omega$ , for single-ended in, differential out. **Boldface** limits apply at the temperature extremes.

Symbol	Parameter	Conditions	Min <sup>(2)</sup>	Typ <sup>(3)</sup>	Max <sup>(2)</sup>	Units
<b>AC Performance (Differential)</b>						
SSBW	Small Signal -3 dB Bandwidth <sup>(2)</sup>	$V_{OUT} = 0.2 V_{PP}$ , $A_V = 1$ , $R_L = 1 k\Omega$		875		MHz
		$V_{OUT} = 0.2 V_{PP}$ , $A_V = 1$		630		
		$V_{OUT} = 0.2 V_{PP}$ , $A_V = 2$		580		
		$V_{OUT} = 0.2 V_{PP}$ , $A_V = 4$		540		
		$V_{OUT} = 0.2 V_{PP}$ , $A_V = 8$ , ( $R_F = 400\Omega$ , $R_G = 50\Omega$ )		315		
LSBW	Large Signal -3 dB Bandwidth	$V_{OUT} = 2 V_{PP}$ , $A_V = 1$ , $R_L = 1 k\Omega$		640		MHz
		$V_{OUT} = 2 V_{PP}$ , $A_V = 1$		485		
		$V_{OUT} = 2 V_{PP}$ , $A_V = 2$		435		
		$V_{OUT} = 2 V_{PP}$ , $A_V = 4$		420		
		$V_{OUT} = 2 V_{PP}$ , $A_V = 8$ , ( $R_F = 400\Omega$ , $R_G = 50\Omega$ )		405		
	0.1 dB Bandwidth	$V_{OUT} = 0.2 V_{PP}$ , $A_V = 1$		60		MHz
	0.5 dB Bandwidth	$V_{OUT} = 0.2 V_{PP}$ , $A_V = 1$		236		MHz
	Slew Rate	2V Step, $A_V = 1$		1350		V/ $\mu s$
	Rise/Fall Time, 10%-90%	2V Step		860		ps
	0.1% Settling Time	2V Step		10		ns
	1.0% Settling Time	2V Step		6		ns
<b>Distortion and Noise Response</b>						
HD2	2 <sup>nd</sup> Harmonic Distortion	$V_{OUT} = 2 V_{PP}$ , $f = 20 MHz$ , $R_L = 800\Omega$		-80		dBc
		$V_{OUT} = 2 V_{PP}$ , $f = 70 MHz$ , $R_L = 800\Omega$		-72		

- (1) Electrical Table values apply only for factory testing conditions at the temperature indicated. Factory testing conditions result in very limited self-heating of the device such that  $T_J = T_A$ . No specification of parametric performance is indicated in the electrical tables under conditions of internal self-heating where  $T_J > T_A$ . See [Application Information](#) for information on temperature de-rating of this device." Min/Max ratings are based on product characterization and simulation. Individual parameters are tested as noted.
- (2) Limits are 100% production tested at 25°C. Limits over the operating temperature range are specified through correlation using Statistical Quality Control (SQC) methods.
- (3) Typical values represent the most likely parametric norm as determined at the time of characterization. Actual typical values may vary over time and will also depend on the application and configuration. The typical values are not tested and are not ensured on shipped production material.

### $V_S = \pm 2.5V$ Electrical Characteristics <sup>(1)</sup> (continued)

Unless otherwise specified, all limits are ensured for  $T_A = 25^\circ C$ ,  $V_S = \pm 2.5V$ ,  $A_V = 1$ ,  $V_{CM} = 0V$ ,  $V_{CLAMP} = 2V$ ,  $R_F = R_G = 275\Omega$ ,  $R_L = 200\Omega$ , for single-ended in, differential out. **Boldface** limits apply at the temperature extremes.

Symbol	Parameter	Conditions	Min <sup>(2)</sup>	Typ <sup>(3)</sup>	Max <sup>(2)</sup>	Units
HD3	3 <sup>rd</sup> Harmonic Distortion	$V_{OUT} = 2 V_{PP}$ , $f = 20$ MHz, $R_L = 800\Omega$		-78		dBc
		$V_{OUT} = 2 V_{PP}$ , $f = 70$ MHz, $R_L = 800\Omega$		-66		
IMD3	3rd-Order Two-Tone Intermodulation	$f_c = 20$ MHz, $V_{OUT} = 2 V_{PP}$ Composite, $R_L = 200\Omega$		-87		dBc
		$f_c = 150$ MHz, $V_{OUT} = 2 V_{PP}$ Composite, $R_L = 200\Omega$		-68		
	Input Noise Voltage	$f = 100$ kHz		1.1		nV/ $\sqrt{Hz}$
	Input Noise Current	$f = 100$ kHz		13.6		pA/ $\sqrt{Hz}$
	Noise Figure (See <a href="#">Figure 58</a> )	50 $\Omega$ System, $A_V = 9, 10$ MHz		10.3		dB
<b>Input Characteristics</b>						
$I_{BI}$	Input Bias Current <sup>(4)(5)</sup>	<sup>(5)</sup>	-90	45	90	$\mu A$
$I_{Boffset}$	Input Bias Current Differential <sup>(3)</sup>	$V_{CM} = 0V$ , $V_{ID} = 0V$ , $I_{Boffset} = (I_{B^-} - I_{B^+})/2$	-24	2	24	$\mu A$
CMRR	Common Mode Rejection Ratio <sup>(3)</sup>	DC, $V_{CM} = 0V$ , $V_{ID} = 0V$		80		dBc
$R_{IN}$	Input Resistance	Differential		15		$\Omega$
$C_{IN}$	Input Capacitance	Differential		0.5		pF
CMVR	Input Common Mode Voltage Range	CMRR > 38 dB	$\pm 1.0$	$\pm 1.2$		V
<b>Output Performance</b>						
	Output Voltage Swing <sup>(3)</sup>	Differential Output	5.32	5.47		$V_{PP}$
$I_{OUT}$	Linear Output Current <sup>(3)</sup>	$V_{OUT} = 0V$	$\pm 75$	$\pm 95$		mA
$I_{SC}$	Short Circuit Current	One Output Shorted to Ground $V_{IN} = 2V$ Single-Ended <sup>(6)</sup>		$\pm 140$		mA
<b>Clamp Performance</b>						
$V_{CLAMP}$	$V_{CLAMP}$ Voltage Range	Continuous Operation <sup>(7)</sup>	$V_{CM}$		$V_{CM} + 2.0$	V
	$V_{CLAMP}$ Peak Voltage	<sup>(8)</sup>			$V_{CM} + 3.0$	
	Default $V_{CLAMP}$ Voltage	$V_{CLAMP}$ Floating	0.42	0.48	0.54	V
	Upper Clamp Level Accuracy	$V_{IN} = 0V$ , $V_{CLAMP} = +0.5V$ , $V_{CM} = 0$ , $V_O = +0.5V$ , 100% Overdrive	-39	-30	+39	mV
	Lower Clamp Level Accuracy	$V_{IN} = 0V$ , $V_{CLAMP} = +0.5V$ , $V_{CM} = 0$ , $V_O = -0.5V$ , 100% Overdrive	-18	6	+18	
	Clamp Accuracy Temperature Drift			-0.1		mV/ $^\circ C$
	Clamp Pin Bias Current	$V_{IN} = 0V$ , $V_{CLAMP} = 1V$ , $V_{CM} = 0$		23.5		$\mu A$
	Clamp Pin Bias Drift			0.3		$\mu A/^\circ C$
	Diff Amp Input Bias Shift	Linear to Clamped Operation		50		$\mu A$
	Clamp Pin Input Impedance			30 1		k $\Omega$ /pF
	Clamp Pin Feedthrough	$f = 10$ MHz		-60		dB
	Clamp Bandwidth	$0.5V_{DC} + 40$ mV $_{PP}$ , SE $V_{IN} = 2V$		125		MHz
	Clamp Slew Rate	100% Overdrive		52		V/ $\mu s$

(4) Exceeding limits could result in excessive device current.

(5)  $I_{BI}$  is referred to a differential output offset voltage by the following relationship:  $V_{OD(Offset)} = I_{BI} \cdot 2R_F$

(6) Short circuit current should be limited in duration to no more than 10 seconds. See [POWER DISSIPATION](#) in [Application Information](#) for more details.

(7) Exceeding limits could result in excessive device current.

(8) This parameter is ensured by design and/or characterization and is not tested in production. The condition of  $V_{CLAMP} = 3V$  is not intended for continuous operation; continuous operation with  $V_{CLAMP} = 3V$  may incur permanent damage to the device.

**$V_S = \pm 2.5V$  Electrical Characteristics <sup>(1)</sup> (continued)**

Unless otherwise specified, all limits are ensured for  $T_A = 25^\circ C$ ,  $V_S = \pm 2.5V$ ,  $A_V = 1$ ,  $V_{CM} = 0V$ ,  $V_{CLAMP} = 2V$ ,  $R_F = R_G = 275\Omega$ ,  $R_L = 200\Omega$ , for single-ended in, differential out. **Boldface** limits apply at the temperature extremes.

Symbol	Parameter	Conditions	Min <sup>(2)</sup>	Typ <sup>(3)</sup>	Max <sup>(2)</sup>	Units
	Clamp Overshoot	$V_{IN} = 1V$ Step, $A_V = 2 V/V$ , $V_{CLAMP} = 0.5V$ , $V_{CM} = 0V$ , 100% Overdrive		105		mV
	Clamp Overshoot	$V_{IN} = 1V$ Step, $A_V = 2 V/V$ , $V_{CLAMP} = 1V$ , $V_{CM} = 0.5V$ , 100% Overdrive		105		mV
	Clamp Overshoot Width	<sup>(9)</sup>		650		ps
	Clamp Overdrive Recovery Time	$V_{IN} = 2V$ Step, $A_V = 2 V/V$ , $V_{CLAMP} = 0.5V$ , $V_{CM} = 0V$ , 50% Output Crossing		600		ps
	Linearity Guardband <sup>(10)</sup>	$f = 75$ MHz, $V_{OD} = 2 V_{PP}$ , $R_L = 800$ , SFDR Down 3 dB		40		mV
<b>Output Common Mode Control Circuit</b>						
	Common Mode Small Signal Bandwidth	$V_{IN^+} = V_{IN^-} = 0$		130		MHz
	Slew Rate	$V_{IN^+} = V_{IN^-} = 0$		186		V/ $\mu$ s
$V_{OSCM}$	Output Common Mode Error	Common Mode, $V_{IN} = \text{float}$ , $V_{CM} = 0$	-20	2	20	mV
	Input Bias Current	$V_{CM} = 0$ , <sup>(11)</sup>		-3.5		$\mu$ A
	Voltage Range		$\pm 0.75$	$\pm 0.81$		V
	CMRR	Measure $V_{OD}$ , $V_{ID} = 0V$		84		dB
	Input Resistance			200		k $\Omega$
	Gain	$\Delta V_{O,CM} / \Delta V_{CM}$	0.995	1.00	1.008	V/V
<b>Miscellaneous Performance</b>						
$Z_T$	Open Loop Transimpedance	Differential		105		dB $\Omega$
PSRR	Power Supply Rejection Ratio	DC, $\Delta V_S = \pm 1V$		85		dB
$I_S$	Supply Current	$R_L = \infty$	23	26.5	30 <b>34</b>	mA

(9) Clamp Overshoot Width is the duration of overshoot in a 100% overdrive condition.

(10) Linearity Guardband is defined for an output sinusoid ( $f = 75$  MHz,  $V_{OD} = 2 V_{PP}$ ). It is the difference between the  $V_{CLAMP}$  level and the peak output voltage where the SFDR is decreased by 3 dB.

(11) Negative current implies current flowing out of the device.

**CONNECTION DIAGRAM**

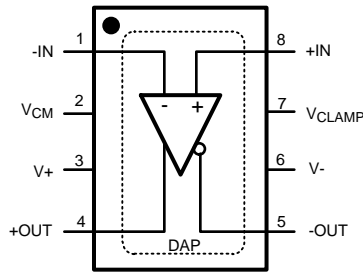

**Figure 2. 8-Pin SO PowerPAD  
Top View**

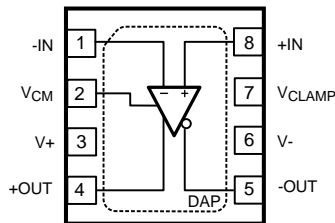

**Figure 3. 8-Pin WSON  
Top View**



**PIN DESCRIPTIONS**

Pin No.	Pin Name	Description
1	-IN	Negative Input
2	$V_{CM}$	Output Common Mode Control
3	V+	Positive Supply
4	+OUT	Positive Output
5	-OUT	Negative Output
6	V-	Negative Supply
7	$V_{CLAMP}$	Output Voltage Clamp Control
8	+IN	Positive Input
DAP	DAP	Die Attach Pad (See <a href="#">THERMAL PERFORMANCE</a> for more information)

Typical Performance Characteristics  $V_S = \pm 5V$

( $T_A = 25^\circ C$ ,  $R_F = R_G = 275\Omega$ ,  $R_L = 200\Omega$ ,  $A_V = 1$ , for single ended in, differential out, unless specified).

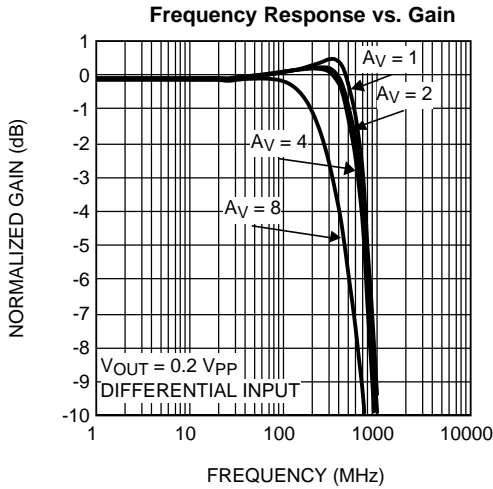

Figure 4.

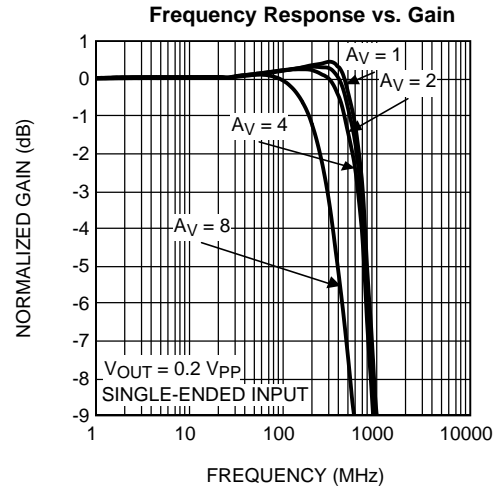

Figure 5.

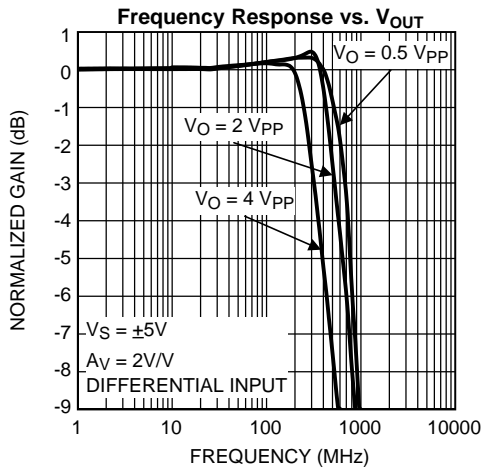

Figure 6.

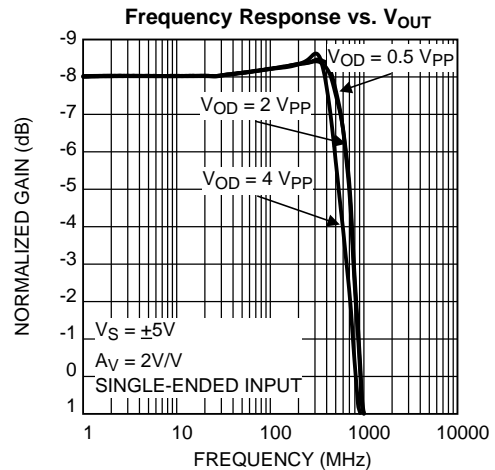

Figure 7.

Frequency Response vs. Supply Voltage ( $R_L = 200\Omega$ )

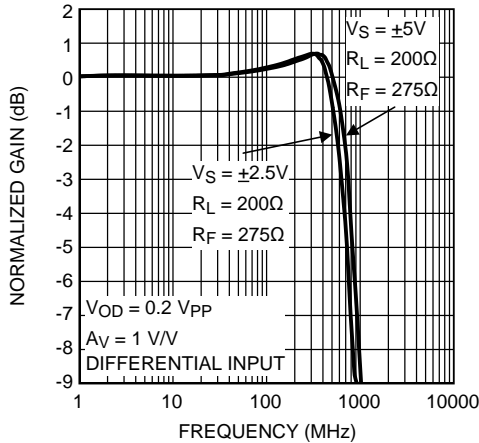

Figure 8.

Frequency Response vs. Supply Voltage ( $R_L = 1\text{ k}\Omega$ )

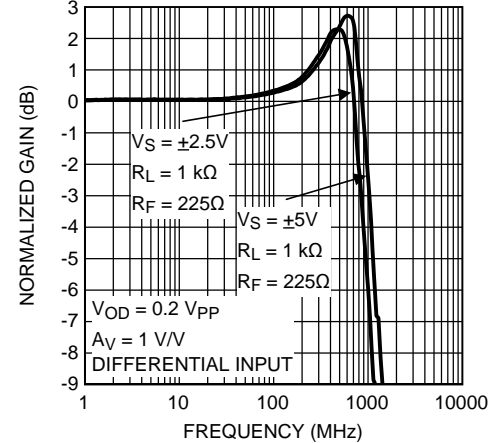

Figure 9.

Typical Performance Characteristics  $V_S = \pm 5V$  (continued)

( $T_A = 25^\circ C$ ,  $R_F = R_G = 275\Omega$ ,  $R_L = 200\Omega$ ,  $A_V = 1$ , for single ended in, differential out, unless specified).

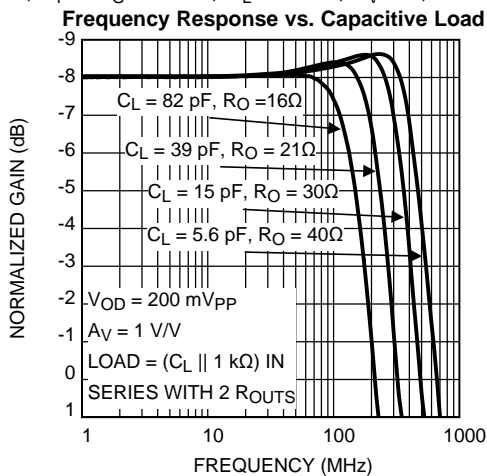

Figure 10.

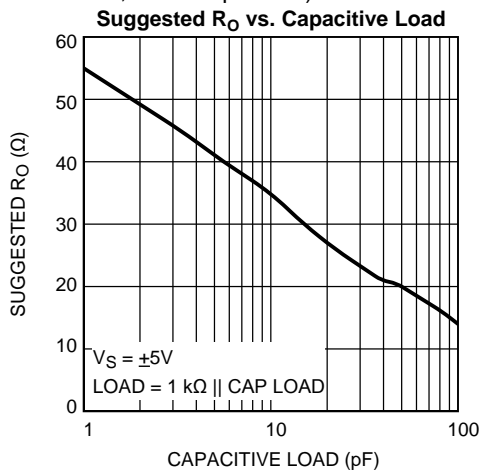

Figure 11.

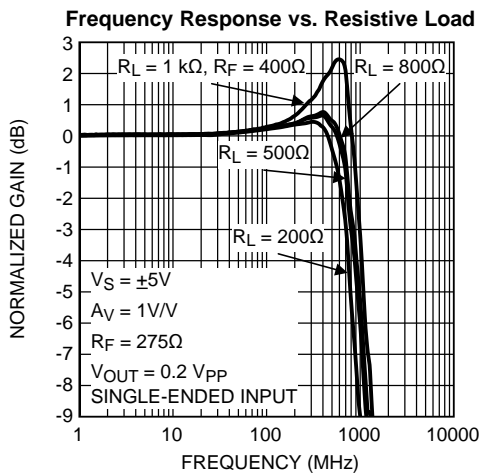

Figure 12.

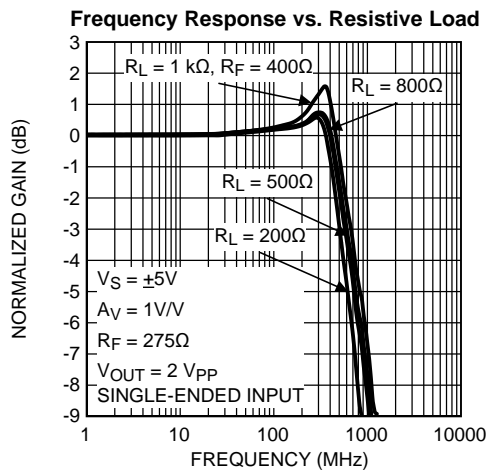

Figure 13.

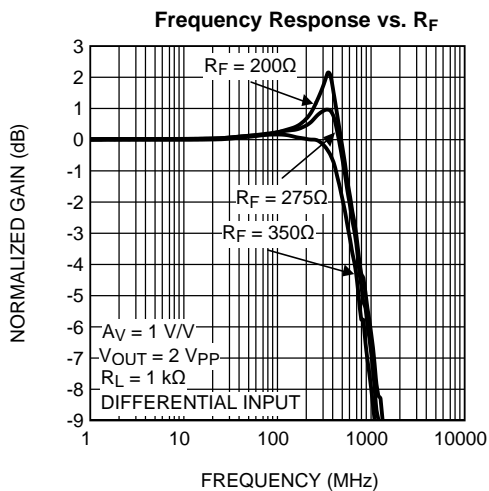

Figure 14.

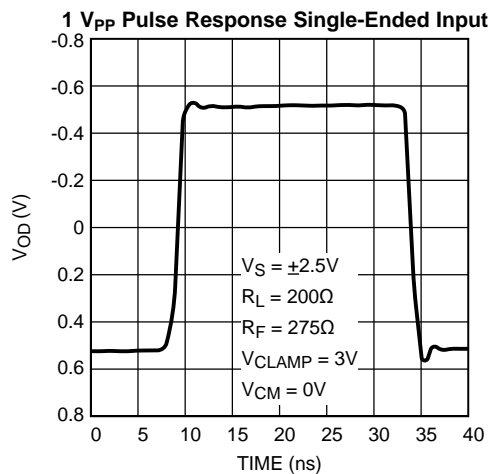

Figure 15.

Typical Performance Characteristics  $V_S = \pm 5V$  (continued)

( $T_A = 25^\circ C$ ,  $R_F = R_G = 275\Omega$ ,  $R_L = 200\Omega$ ,  $A_V = 1$ , for single ended in, differential out, unless specified).

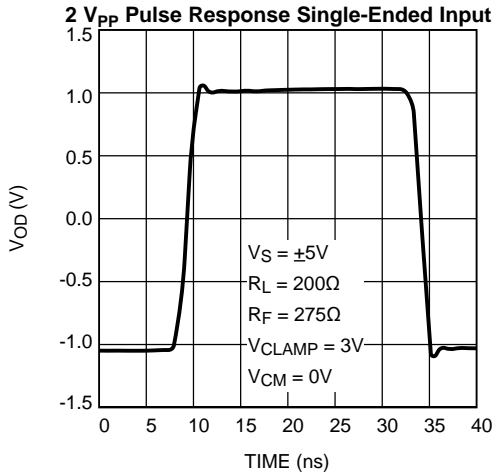

Figure 16.

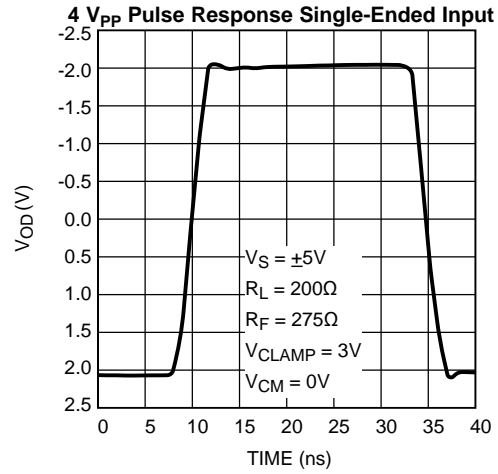

Figure 17.

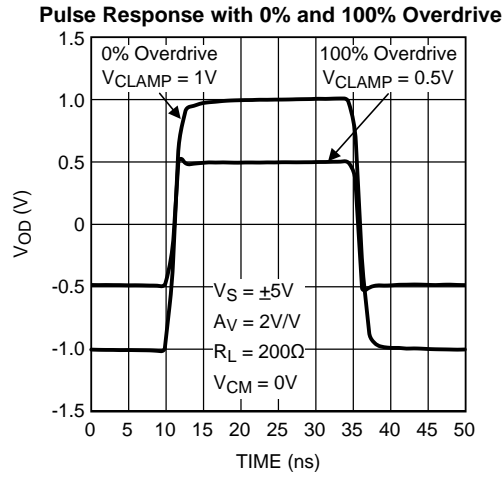

Figure 18.

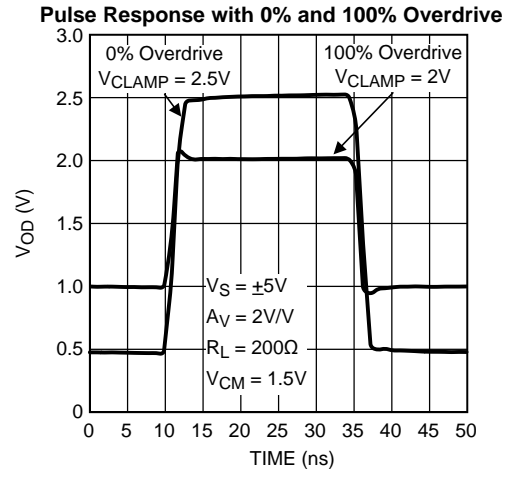

Figure 19.

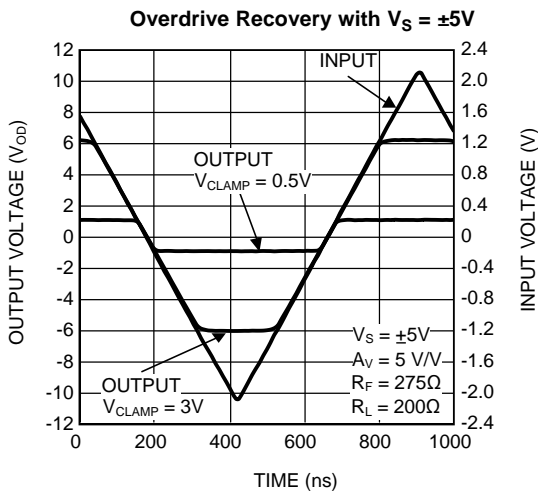

Figure 20.

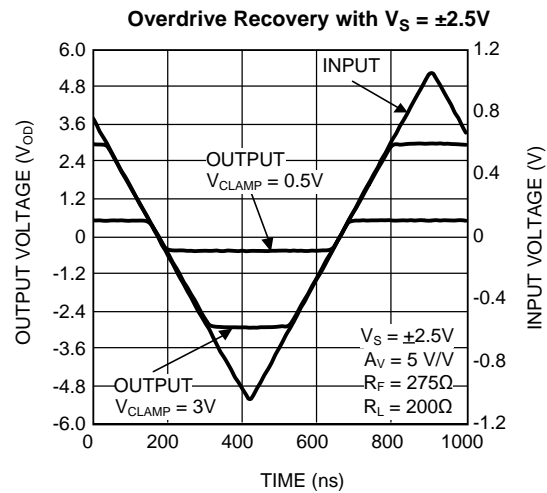

Figure 21.

Typical Performance Characteristics  $V_S = \pm 5V$  (continued)

( $T_A = 25^\circ C$ ,  $R_F = R_G = 275\Omega$ ,  $R_L = 200\Omega$ ,  $A_V = 1$ , for single ended in, differential out, unless specified).

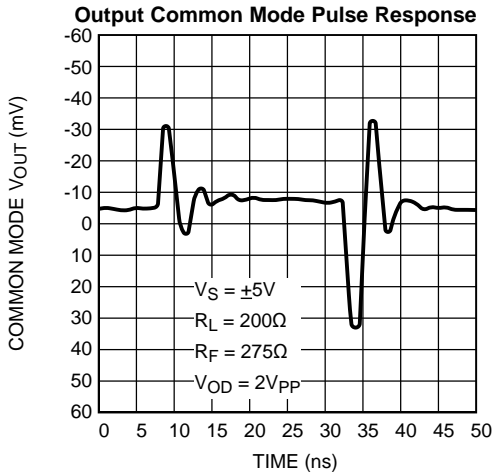

Figure 22.

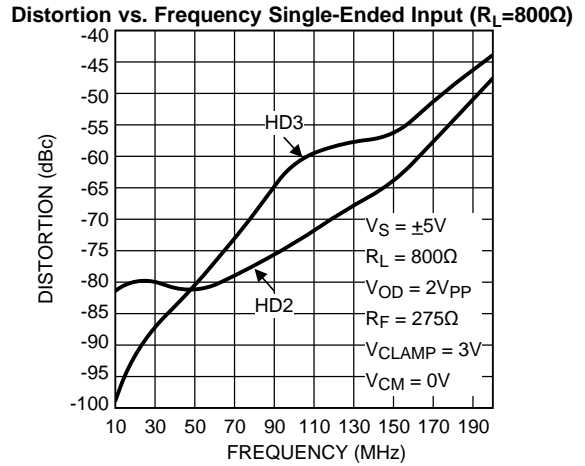

Figure 23.

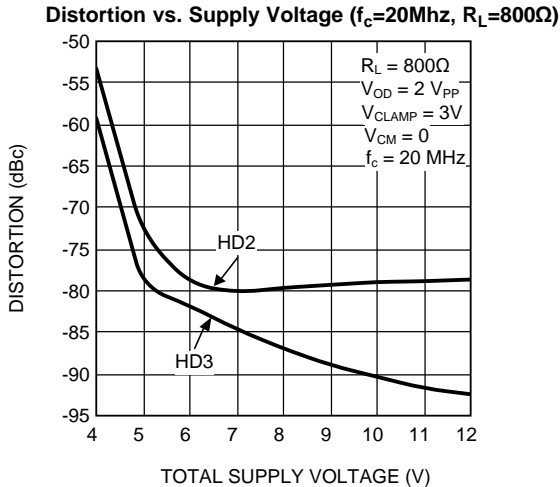

Figure 24.

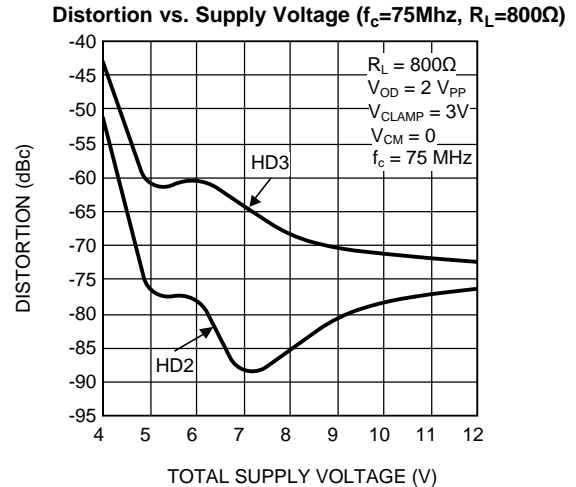

Figure 25.

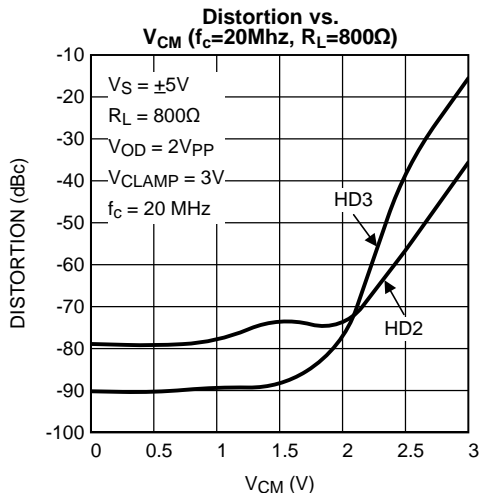

Figure 26.

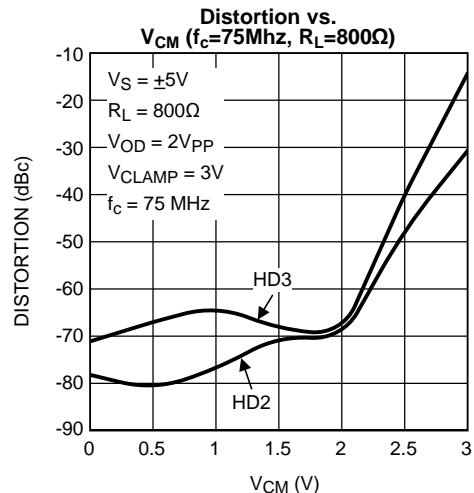

Figure 27.

**Typical Performance Characteristics  $V_S = \pm 5V$  (continued)**

( $T_A = 25^\circ C$ ,  $R_F = R_G = 275\Omega$ ,  $R_L = 200\Omega$ ,  $A_V = 1$ , for single ended in, differential out, unless specified).

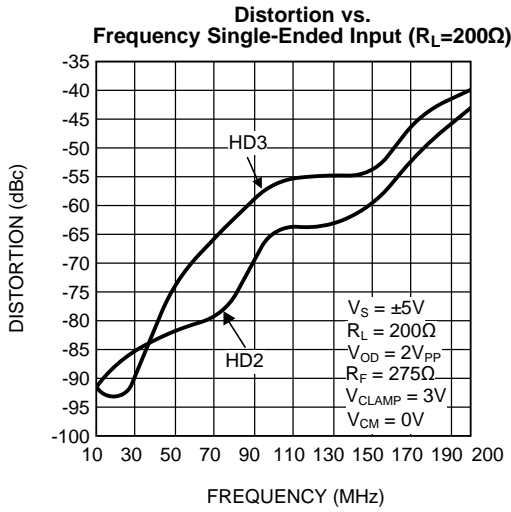

Figure 28.

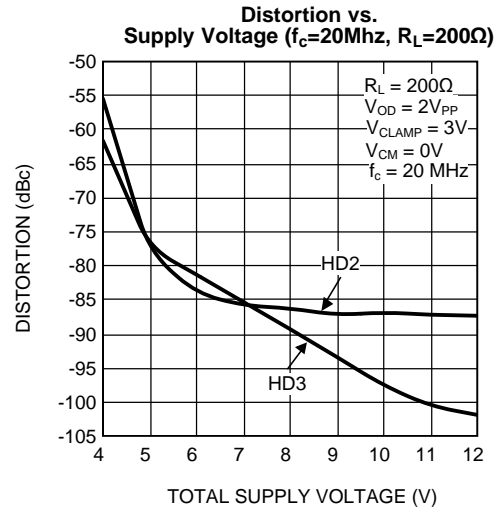

Figure 29.

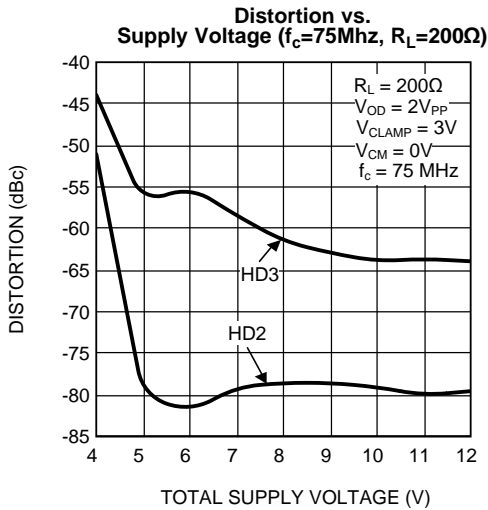

Figure 30.

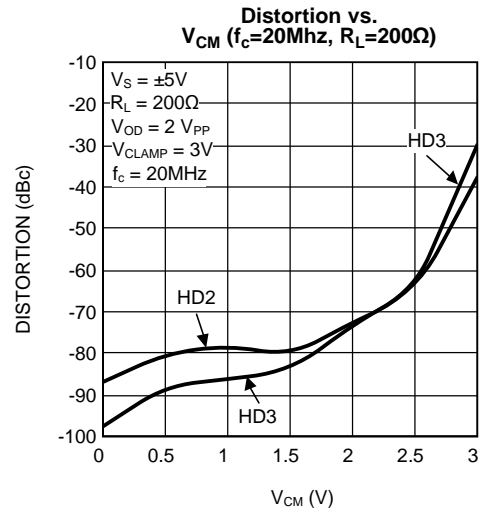

Figure 31.

**Typical Performance Characteristics  $V_S = \pm 5V$  (continued)**

( $T_A = 25^\circ C$ ,  $R_F = R_G = 275\Omega$ ,  $R_L = 200\Omega$ ,  $A_V = 1$ , for single ended in, differential out, unless specified).

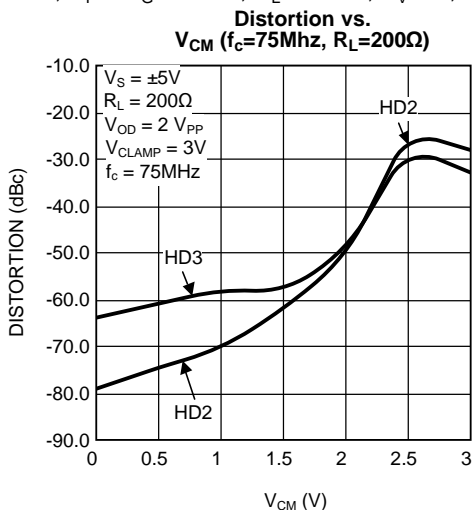

Figure 32.

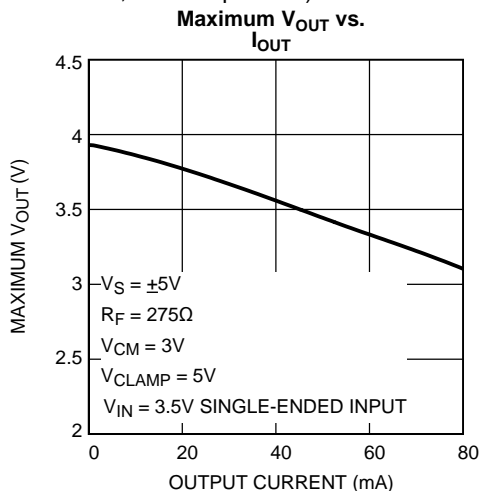

Figure 33.

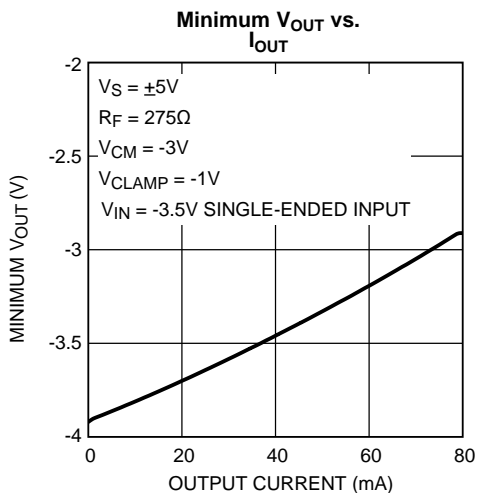

Figure 34.

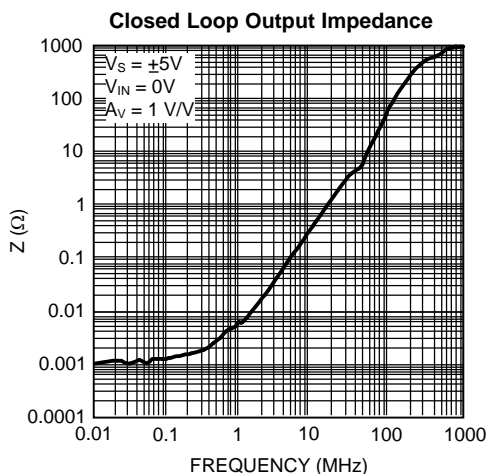

Figure 35.

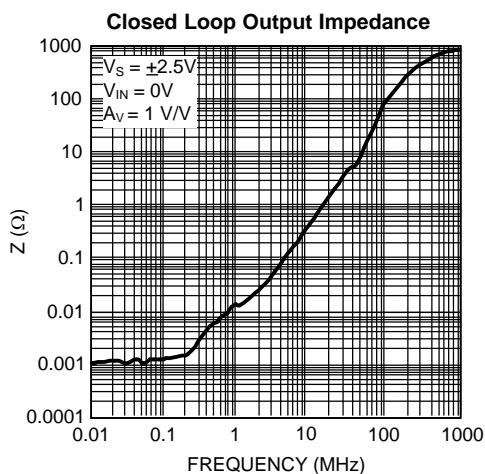

Figure 36.

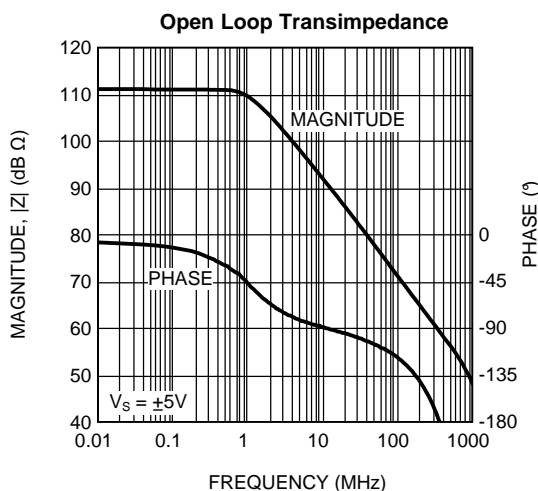

Figure 37.

Typical Performance Characteristics  $V_S = \pm 5V$  (continued)

( $T_A = 25^\circ C$ ,  $R_F = R_G = 275\Omega$ ,  $R_L = 200\Omega$ ,  $A_V = 1$ , for single ended in, differential out, unless specified).

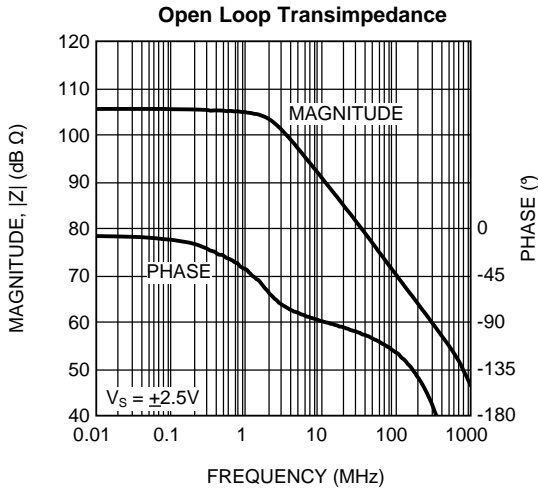

Figure 38.

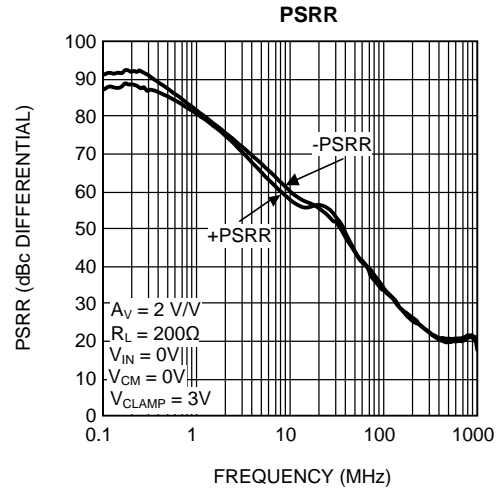

Figure 39.

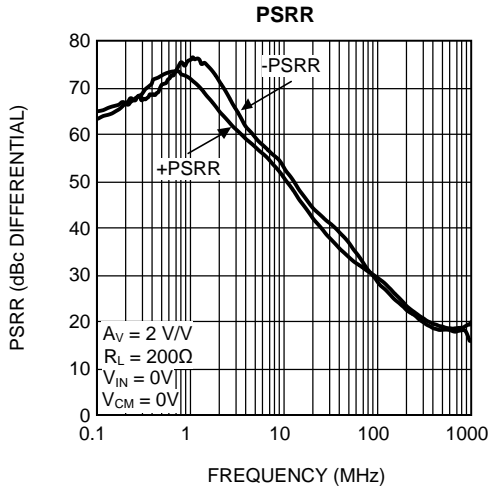

Figure 40.

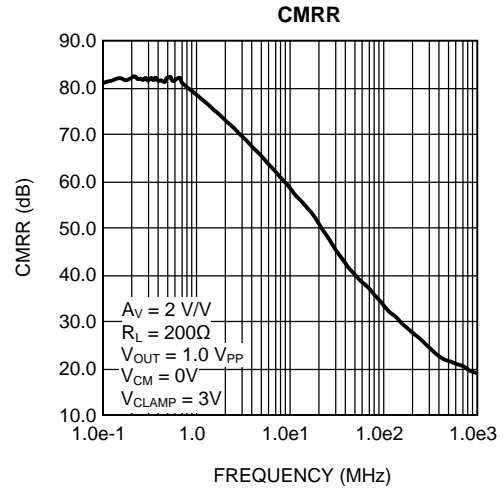

Figure 41.

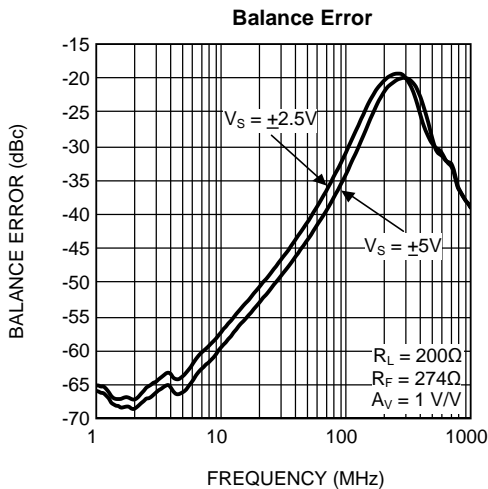

Figure 42.

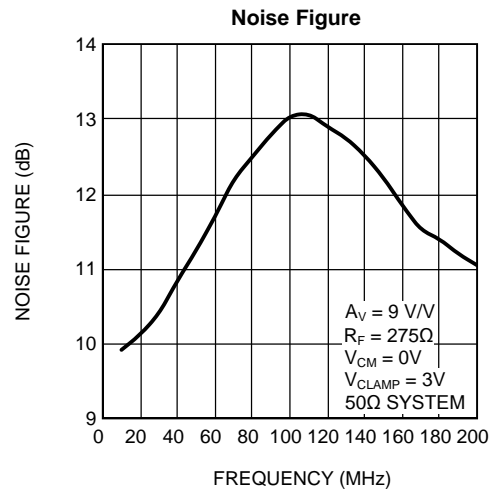

Figure 43.



**Typical Performance Characteristics  $V_S = \pm 5V$  (continued)**

( $T_A = 25^\circ C$ ,  $R_F = R_G = 275\Omega$ ,  $R_L = 200\Omega$ ,  $A_V = 1$ , for single ended in, differential out, unless specified).

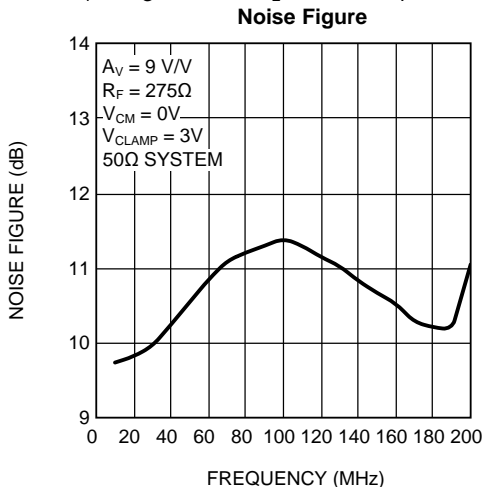

Figure 44.

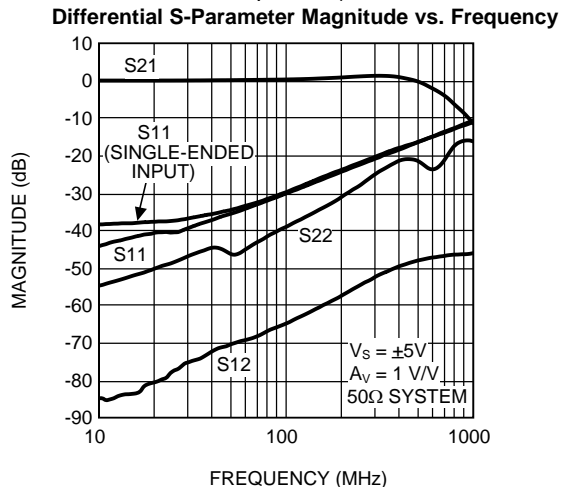

Figure 45.

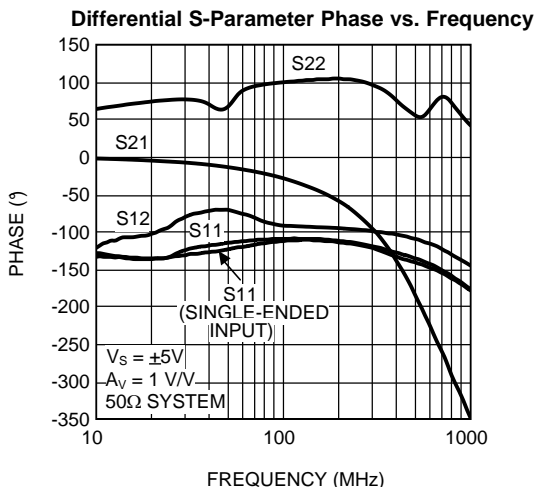

Figure 46.

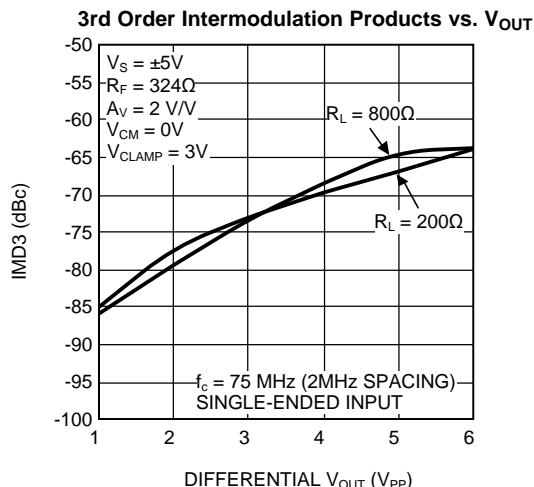

Figure 47.

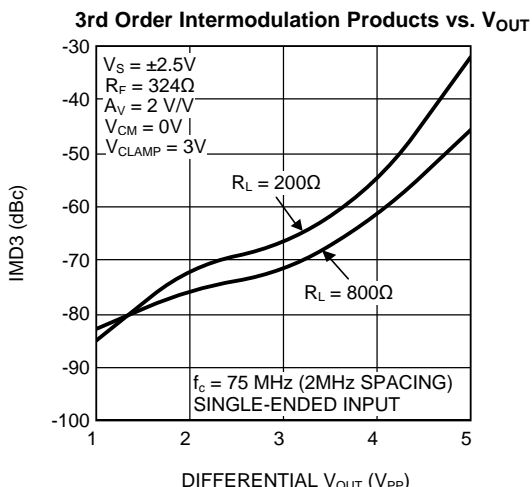

Figure 48.

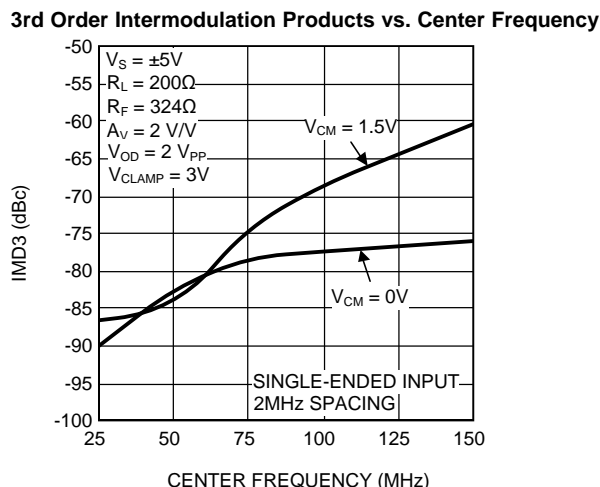

Figure 49.

Typical Performance Characteristics  $V_S = \pm 5V$  (continued)

( $T_A = 25^\circ C$ ,  $R_F = R_G = 275\Omega$ ,  $R_L = 200\Omega$ ,  $A_V = 1$ , for single ended in, differential out, unless specified).

3rd Order Intermodulation Products vs. Center Frequency

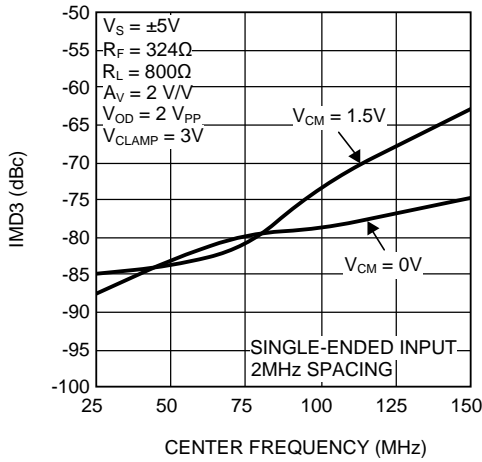

Figure 50.

3rd Order Intermodulation Products vs. Center Frequency

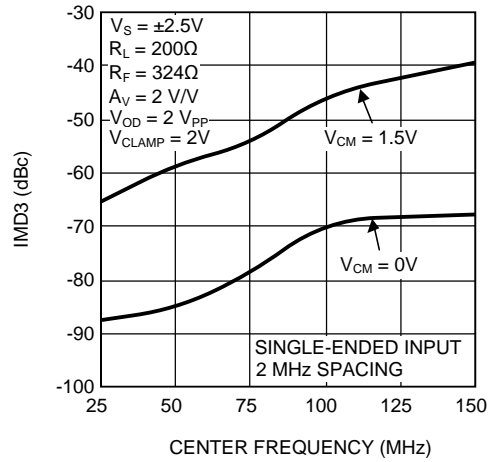

Figure 51.

3rd Order Intermodulation Products vs. Center Frequency

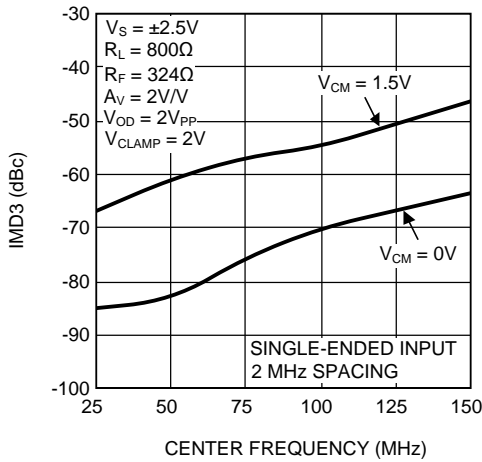

Figure 52.

3rd Order Intermodulation Products vs. VCLAMP

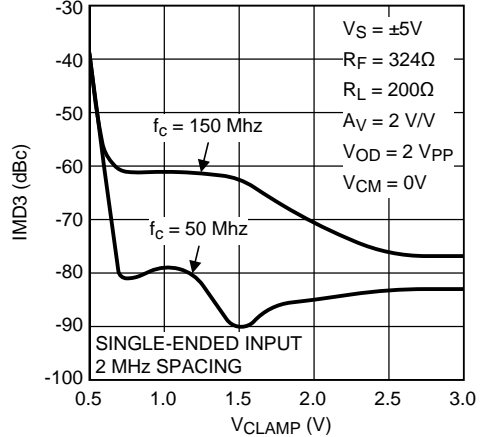

Figure 53.

## APPLICATION INFORMATION

The LMH6553, a fully differential current feedback amplifier with integrated output common mode control and output limiting clamp, is designed to provide protection of following input stages. The common mode feedback circuit sets the output common mode voltage independent of the input common mode, as well as forcing the outputs to be equal in magnitude and opposite in phase, even when only one of the inputs is driven as in single ended to differential conversion.

The proprietary current feedback architecture of the LMH6553 offers gain and bandwidth independence even at high values of gain, simply with the appropriate choice of  $R_{F1}$  and  $R_{F2}$ . Generally  $R_{F1}$  is set equal to  $R_{F2}$ , and  $R_{G1}$  equal to  $R_{G2}$ , so that the gain is set by the ratio  $R_F/R_G$ . Matching of these resistors greatly affects CMRR, DC offset error, and output balance. Resistors with 0.1% tolerances are recommended for optimal performance, and the amplifier is internally compensated to operate with optimum gain flatness with values of  $R_F$  between 250Ω and 350Ω depending on package selection, PCB layout, and load resistance.

The output common mode voltage is set by the  $V_{CM}$  pin with a fixed gain of 1 V/V. This pin should be driven by a low impedance source and should be bypassed to ground with a 0.1 μF ceramic capacitor. Any unwanted signal coupling into the  $V_{CM}$  pin will be passed along to the outputs, reducing the performance of the amplifier. This pin must not be left floating.

The LMH6553 can be operated with either a single 5V supply or split +5V and -5V supplies. Operation on a single 5V supply, depending on gain, is limited by the input common mode range; therefore, AC coupling may be required. For example, in a DC coupled input application on a single 5V supply, with a  $V_{CM}$  of 1.5V, the input common voltage at a gain of 1 will be 0.75V which is outside the minimum 1.5V to 3.5V input common mode range of the amplifier. The minimum  $V_{CM}$  for this application should be greater than 1.5V depending on output signal swing. Alternatively, AC coupling of the inputs in this example results in equal input and output common mode voltages, so a 1.5V input common mode would result. Split supplies allow much less restricted AC and DC coupled operation with optimum distortion performance.

The LMH6553 has a  $V_{CLAMP}$  input which allows control of the maximum amplifier output swing to prevent overdriving of following stages such as sensitive ADC inputs and also provides fast recovery from transients that would otherwise saturate the signal path.

### RECOMMENDED FEEDBACK RESISTOR

The LMH6553 is available in both an 8-pin WSON and SO PowerPAD package. The recommended feedback resistor,  $R_F$ , for the WSON package is 275Ω and 325Ω for the SO PowerPAD to give a flat frequency response with minimal peaking.

### FULLY DIFFERENTIAL OPERATION

The LMH6553 is ideal for a fully differential configuration. The circuit shown in [Figure 54](#) is a typical fully differential application circuit as might be used to drive an analog to digital converter (ADC). In this circuit the closed loop gain  $A_V = V_{OUT}/V_{IN} = R_F/R_G$ , where the feedback is symmetric. The series output resistors,  $R_O$ , are optional and help keep the amplifier stable when presented with a capacitive load. Refer to [DRIVING CAPACITIVE LOADS](#) for details.

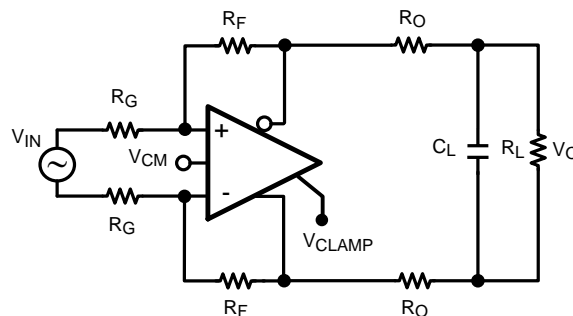

**Figure 54. Typical Application**

When driven from a differential source, the LMH6553 provides low distortion, excellent balance, and common mode rejection. This is true provided the resistors  $R_F$ ,  $R_G$  and  $R_O$  are well matched and strict symmetry is observed in board layout.

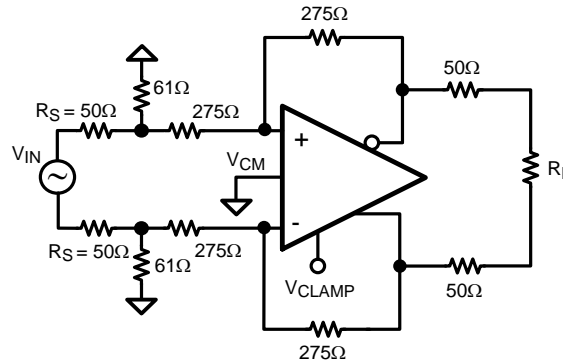

Figure 55. Differential S-Parameter Test Circuit

The circuit configuration shown in Figure 55 was used to measure differential S parameters in a 50Ω environment at a gain of 1 V/V. Refer to Figure 45 and Figure 46 in Typical Performance Characteristics for measurement results.

**SINGLE-ENDED INPUT TO DIFFERENTIAL OUTPUT OPERATION**

In many applications, it is required to drive a differential input ADC from a single-ended source. Traditionally, transformers have been used to provide single to differential conversion, but these are inherently bandpass by nature and cannot be used for DC coupled applications. The LMH6553 provides excellent performance as a single-to-differential converter down to DC. Figure 56 shows a typical application circuit where an LMH6553 is used to produce a differential signal from a single ended source.

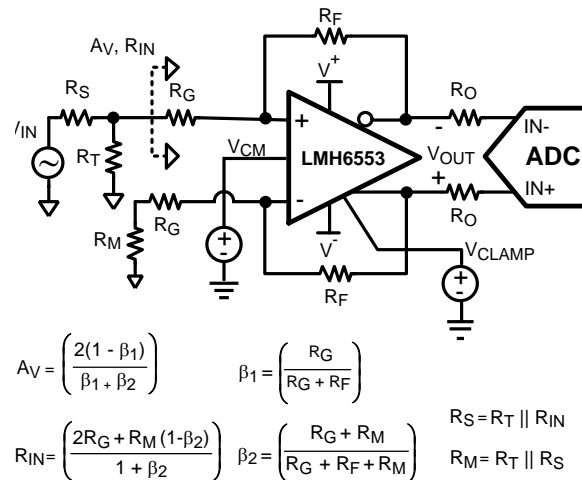

Figure 56. Single-Ended Input with Differential Output

When using the LMH6553 in single-to-differential mode, the complementary output is forced to a phase inverted replica of the driven output by the common mode feedback circuit as opposed to being driven by its own complementary input. Consequently, as the driven input changes, the common mode feedback action results in a varying common mode voltage at the amplifier's inputs, proportional to the driving signal. Due to the non-ideal common mode rejection of the amplifier's input stage, a small common mode signal appears at the outputs which is superimposed on the differential output signal. The ratio of the change in output common mode voltage to output differential voltage is commonly referred to as output balance error. The output balance error response of the LMH6553 over frequency is shown in the Typical Performance Characteristics.

To match the input impedance of the circuit in [Figure 56](#) to a specified source resistance,  $R_S$ , requires that  $R_T \parallel R_{IN} = R_S$ . The equations governing  $R_{IN}$  and  $A_V$  for single-to-differential operation are also provided in [Figure 56](#). These equations, along with the source matching condition, must be solved iteratively to achieve the desired gain with the proper input termination. Component values for several common gain configurations in a 50Ω environment are given in [Table 1](#).

**Table 1. Gain Component Values for 50Ω System WSON Package**

Gain	$R_F$	$R_G$	$R_T$	$R_M$
0 dB	275Ω	255Ω	59Ω	26.7Ω
6 dB	275Ω	127Ω	68.1Ω	28.7Ω
12 dB	275Ω	54.9Ω	107Ω	34Ω

**Table 2. Gain Component Values for 50Ω System SO PowerPAD Package**

Gain	$R_F$	$R_G$	$R_T$	$R_M$
0 dB	325Ω	316Ω	56.2Ω	26.7Ω
6 dB	325Ω	150Ω	64.9Ω	28Ω
12 dB	325Ω	68.1Ω	88.7Ω	31.6Ω

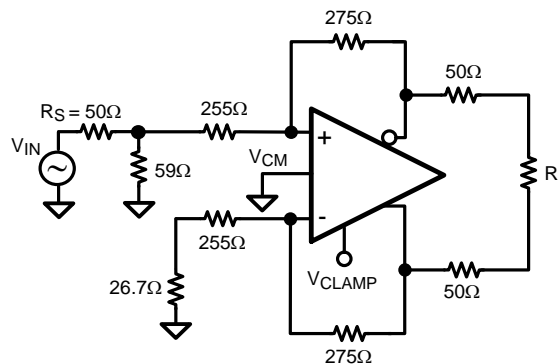
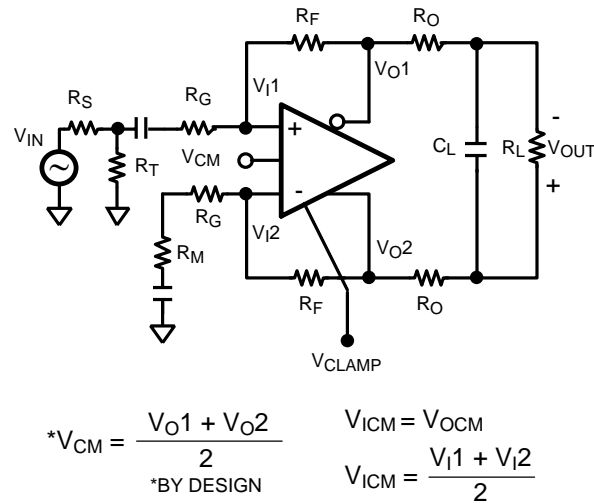

**Figure 57. Single Ended Input S-Parameter Test Circuit (50Ω System)**

The circuit shown in [Figure 57](#) was used to measure S-parameters for a single-to-differential configuration. [Figure 45](#) and [Figure 46](#) in [Typical Performance Characteristics](#) are taken using the recommended component values for 0 dB gain.

### SINGLE SUPPLY OPERATION

Single supply operation is possible on supplies from 5V to 10V; however, as discussed earlier, AC input coupling is recommended for low supplies due to input common mode limitations. An example of an AC coupled, single supply, single-to-differential circuit is shown in [Figure 58](#). Note that when AC coupling, both inputs need to be AC coupled irrespective of single-to-differential or differential-to-differential configuration. For higher supply voltages, DC coupling of the inputs may be possible provided that the output common mode DC level is set high enough so that the amplifier's inputs and outputs are within their specified operating ranges.



**Figure 58. AC Coupled for Single Supply Operation**

## SPLIT SUPPLY OPERATION

For optimum performance, split supply operation is recommended using +5V and -5V supplies; however, operation is possible on split supplies as low as +2.25V and -2.25V and as high as +6V and -6V. Provided the total supply voltage does not exceed the 4.5V to 12V operating specification, asymmetric supply operation is also possible and in some cases advantageous. For example, if 5V DC coupled operation is required for low power dissipation but the amplifier input common mode range prevents this operation, it is still possible with split supplies of ( $V^+$ ) and ( $V^-$ ). Where ( $V^+$ ) - ( $V^-$ ) = 5V and  $V^+$  and  $V^-$  are selected to set the amplifier input common mode voltage to suit the application.

## CLAMP OPERATION

The output clamp allows control of the maximum amplifier output swing to prevent overdriving of following stages such as sensitive ADC inputs and provide fast recovery from signal transients that would otherwise saturate the signal path. Figure 59 shows the relationship between  $V_{CLAMP}$  and the +OUT and -OUT outputs. The example circuit shown has a single ended input and is set for a gain of 2 V/V. For proper operation  $V_{CM} < V_{CLAMP} < V_{CM} + 2.0V$  and the upper single ended output voltage is limited to the voltage level set at the  $V_{CLAMP}$  input. The output common mode control loop forces the lower single ended voltage to be limited to  $2*V_{CM} - V_{CLAMP}$ . The maximum clamped single ended output swing is therefore equal to  $2*(V_{CLAMP} - V_{CM})$  and the maximum differential output swing is therefore equal to  $4*(V_{CLAMP} - V_{CM})$ . In the example of Figure 59 with  $V_{CLAMP}$  set to 2V and  $V_{CM}$  set to 1.5V, the maximum single ended output is therefore 1  $V_{PP}$  centered at 1.5V and the maximum differential output is 2  $V_{PP}$ . This is shown for the case of a 2  $V_{PP}$  input sine wave which for a gain of 2 V/V in unclamped operation would provide single ended outputs at +OUT and -OUT of 2  $V_{PP}$  but is shown being clamp limited to 1  $V_{PP}$ .

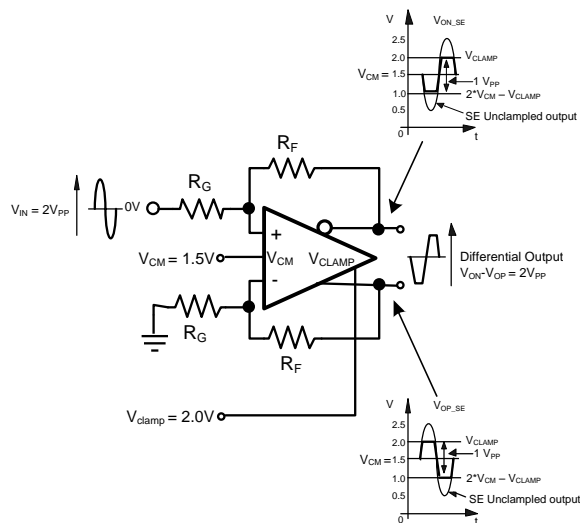

Figure 59. Clamp Operation

### CLAMP PERFORMANCE

Key clamp performance specifications are listed in the electrical characteristics section. Figure 60 illustrates the clamp overdrive recovery time which is defined as the difference in input to output propagation delay due to a step change at the input for a clamped output versus a normal linear unclamped, non-saturated output.

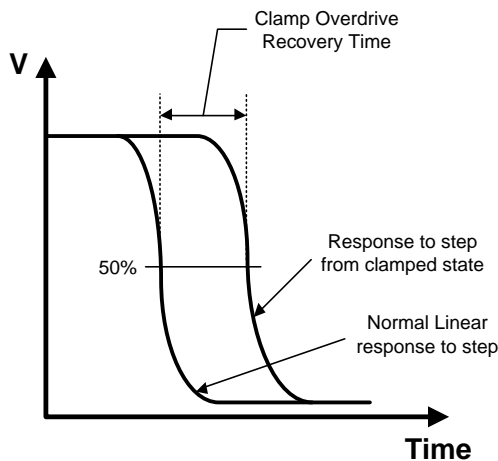

Figure 60. Clamp Overdrive Recovery Time

### MAXIMUM OUTPUT LEVEL

The maximum unclamped output swing in normal operation is  $4V_{PP}$  single ended or  $8V_{PP}$  differential due to the requirement that  $V_{CLAMP} < V_{CM} + 2.0V$ . For split supply operation of  $+5V$  and  $-5V$ , the maximum output voltage is limited by the output stage's ability to swing close to either supply ( $V_{OUT} < \pm 3.7V$ ). As shown in Figure 61, if  $V_{CLAMP}$  is set  $> 3.7V$ , the amplifier output will saturate at the positive supply before the clamp can operate and similarly if  $2 \cdot V_{CM} - V_{CLAMP} < -3.7V$ , the amplifier output will saturate at the negative supply.

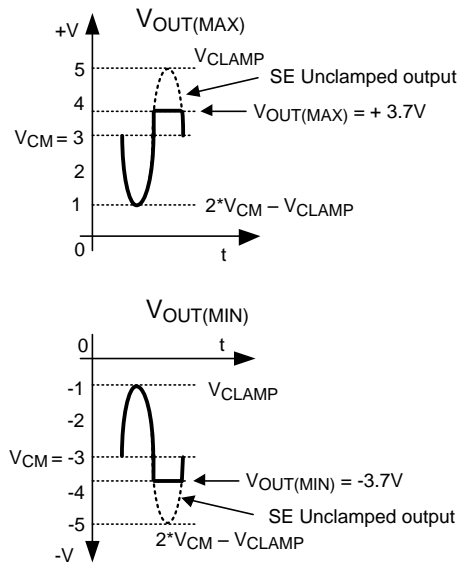

Figure 61. Split Supply  $V_{OUT(MAX)}$  and  $V_{OUT(MIN)}$  Output Levels

**OUTPUT NOISE PERFORMANCE AND MEASUREMENT**

Unlike differential amplifiers based on voltage feedback architectures, noise sources internal to the LMH6553 refer to the inputs largely as current sources, hence the low input referred voltage noise and relatively higher input referred current noise. The output noise is therefore more strongly coupled to the value of the feedback resistor and not to the closed loop gain, as would be the case with a voltage feedback differential amplifier. This allows operation of the LMH6553 at much higher gain without incurring a substantial noise performance penalty, simply by choosing a suitable feedback resistor.

Figure 62 shows a circuit configuration used to measure noise figure for the LMH6553 in a 50Ω system. An  $R_F$  value of 275Ω is chosen for the SO PowerPAD package to minimize output noise while simultaneously allowing both high gain (9 V/V) and proper 50Ω input termination. Refer to SINGLE-ENDED INPUT TO DIFFERENTIAL OUTPUT OPERATION for calculation of resistor and gain values. Noise figure values at various frequencies are shown in Figure 43 in Typical Performance Characteristics.

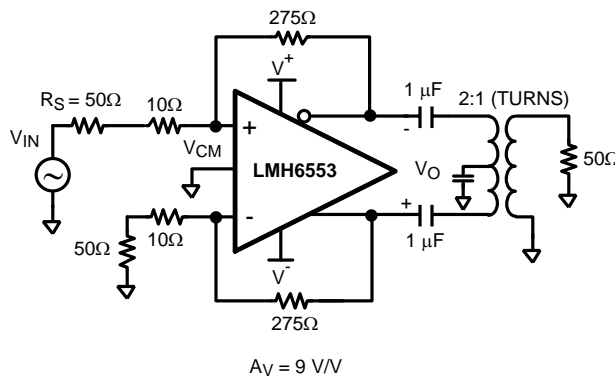

Figure 62. Noise Figure Circuit Configuration



## DRIVING ANALOG TO DIGITAL CONVERTERS

Analog-to-digital converters present challenging load conditions. They typically have high impedance inputs with large and often variable capacitive components. As well, there are usually current spikes associated with switched capacitor or sample and hold circuits. Figure 63 shows the LMH6553 driving the ADC14C105. The amplifier is configured to provide a gain of 2 V/V in a single-to-differential mode. The LMH6553 common mode voltage is set by the ADC14C105. The 0.1  $\mu$ F capacitor, in series with the 49.9 $\Omega$  resistor, is inserted to ground across the 68.1 $\Omega$  resistor to balance the amplifier inputs. The circuit in Figure 63 has a 2nd order lowpass LC filter formed by the 620 nH inductors along with the 22 pF capacitor across the differential inputs of the ADC14C105. The filter has a pole frequency of about 50 MHz. The two 100 $\Omega$  resistors serve to isolate the capacitive loading of the ADC from the amplifier and ensure stability. For switched capacitor input ADCs, the input capacitance will vary based on the clock cycle, as the ADC switches between the sample and hold mode. See your particular ADC's datasheet for details.

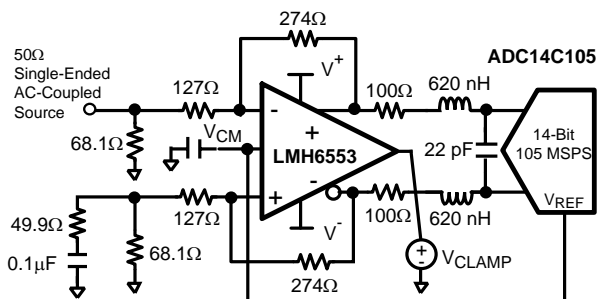

Figure 63. Driving a 14-bit ADC

Figure 64 shows the SFDR and SNR performance vs. frequency for the LMH6553 and ADC14C105 combination circuit with the ADC input signal level at  $-1$  dBFS. The ADC14C105 is a single channel 14-bit ADC with maximum sampling rate of 105 MSPS. The amplifier is configured to provide a gain of 2 V/V in single to differential mode. An external bandpass filter is inserted in series between the input signal source and the amplifier to reduce harmonics and noise from the signal generator. In order to properly match the input impedance seen at the LMH6553 amplifier inputs,  $R_M$  is chosen to match  $Z_S \parallel R_T$  for proper input balance.

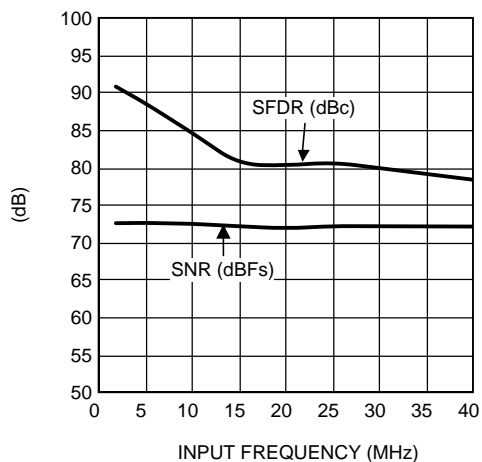

Figure 64. LMH6553/ADC14C105 SFDR and SNR Performance vs. Frequency

The amplifier and ADC should be located as close together as possible. Both devices require that the filter components be in close proximity to them. The amplifier needs to have minimal parasitic loading on its outputs and the ADC is sensitive to high frequency noise that may couple in on its inputs. Some high performance ADCs have an input stage that has a bandwidth of several times its sample rate. The sampling process results in all input signals presented to the input stage mixing down into the first Nyquist zone (DC to  $F_s/2$ ).

The LMH6553 is capable of driving a variety of Texas Instruments Analog-to-Digital Converters. This is shown in [Table 3](#), which offers a list of possible signal path ADC and amplifier combinations. The use of the LMH6553 to drive an ADC is determined by the application and the desired sampling process (Nyquist operation, sub-sampling or over-sampling). See application note AN-236 ([SNAA079](#)) for more details on the sampling processes and application note AN-1393, *Using High Speed Differential Amplifiers to Drive ADCs* ([SNOA461](#)). For more information regarding a particular ADC, refer to the particular ADC datasheet for details.

**Table 3. DIFFERENTIAL INPUT ADCs COMPATIBLE WITH LMH6553 DRIVER**

Product Number	Max Sampling Rate (MSPS)	Resolution	Channels
ADC1173	15	8	SINGLE
ADC1175	20	8	SINGLE
ADC08351	42	8	SINGLE
ADC1175-50	50	8	SINGLE
ADC08060	60	8	SINGLE
ADC08L060	60	8	SINGLE
ADC08100	100	8	SINGLE
ADC08200	200	8	SINGLE
ADC08500	500	8	SINGLE
ADC081000	1000	8	SINGLE
ADC08D1000	1000	8	DUAL
ADC10321	20	10	SINGLE
ADC10D020	20	10	DUAL
ADC10030	27	10	SINGLE
ADC10040	40	10	DUAL
ADC10065	65	10	SINGLE
ADC10DL065	65	10	DUAL
ADC10080	80	10	SINGLE
ADC11DL066	66	11	DUAL
ADC11L066	66	11	SINGLE
ADC11C125	125	11	SINGLE
ADC11C170	170	11	SINGLE
ADC12010	10	12	SINGLE
ADC12020	20	12	SINGLE
ADC12040	40	12	SINGLE
ADC12D040	40	12	DUAL
ADC12DL040	40	12	DUAL
ADC12DL065	65	12	DUAL
ADC12DL066	66	12	DUAL
ADC12L063	63	12	SINGLE
ADC12C080	80	12	SINGLE
ADC12DS080	80	12	DUAL
ADC12L080	80	12	SINGLE
ADC12C105	105	12	SINGLE
ADC12DS105	105	12	DUAL
ADC12C170	170	12	SINGLE
ADC14L020	20	14	SINGLE
ADC14L040	40	14	SINGLE
ADC14C080	80	14	SINGLE
ADC14DS080	80	14	DUAL
ADC14C105	105	14	SINGLE

**Table 3. DIFFERENTIAL INPUT ADCs COMPATIBLE WITH LMH6553 DRIVER (continued)**

Product Number	Max Sampling Rate (MSPS)	Resolution	Channels
ADC14DS105	105	14	DUAL
ADC14155	155	14	SINGLE

### DRIVING CAPACITIVE LOADS

As noted previously, capacitive loads should be isolated from the amplifier outputs with small valued resistors. This is particularly the case when the load has a resistive component that is 500Ω or higher. A typical ADC has capacitive components of around 10 pF and the resistive component could be 1000Ω or higher. If driving a transmission line, such as 50Ω coaxial or 100Ω twisted pair, using matching resistors will be sufficient to isolate any subsequent capacitance.

### BALANCED CABLE DRIVER

With up to 8 V<sub>PP</sub> differential output voltage swing and 100 mA of linear drive current the LMH6553 makes an excellent cable driver as shown in Figure 65. The LMH6553 is also suitable for driving differential cables from a single ended source.

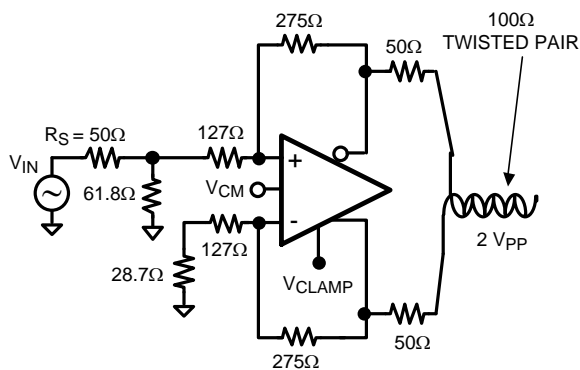

$$A_V = 2 \text{ V/V}$$

**Figure 65. Fully Differential Cable Driver**

### POWER SUPPLY BYPASSING

The LMH6553 requires supply bypassing capacitors as shown in Figure 66 and Figure 67. The 0.01 μF and 0.1 μF capacitors should be leadless SMT ceramic capacitors and should be no more than 3 mm from the supply pins. These capacitors should be star routed with a dedicated ground return plane or trace for best harmonic distortion performance. A small capacitor, ~0.01 μF, placed across the supply rails, and as close to the chip's supply pins as possible, can further improve HD2 performance. Narrow traces or small vias will reduce the effectiveness of bypass capacitors. Also shown in both figures is a capacitor from the V<sub>CM</sub> and V<sub>CLAMP</sub> pins to ground. These inputs are high impedance and can provide a coupling path into the amplifier for external noise sources, possibly resulting in loss of dynamic range, degraded CMRR, degraded balance and higher distortion.

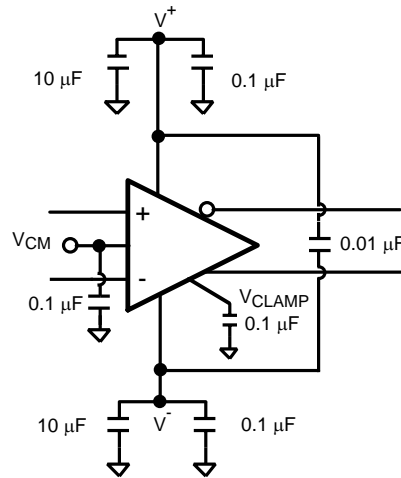

Figure 66. Split Supply Bypassing Capacitors

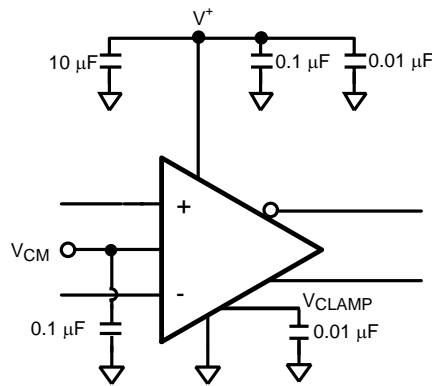

Figure 67. Single Supply Bypassing Capacitors

**POWER DISSIPATION**

The LMH6553 is optimized for maximum speed and performance in the small form factor of the standard WSON package. To ensure maximum output drive and highest performance, thermal shutdown is not provided. Therefore, it is of utmost importance to make sure that the  $T_{JMAX}$  of 150°C is never exceeded.

Follow these steps to determine the maximum power dissipation for the LMH6553:

1. Calculate the quiescent (no-load) power:

$$P_{AMP} = I_{CC} \cdot V_S$$

where

- $V_S = V^+ - V^-$ . (Be sure to include any current through the feedback network if  $V_{CM}$  is not mid-rail.) (1)

2. Calculate the RMS power dissipated in each of the output stages:

$$P_D (rms) = rms ((V_S - V_{OUT}^+) \cdot I_{OUT}^+) + rms ((V_S - V_{OUT}^-) \cdot I_{OUT}^-)$$

where

- $V_{OUT}$  and  $I_{OUT}$  are the voltage and the current measured at the output pins of the differential amplifier as if they were single ended amplifiers and  $V_S$  is the total supply voltage (2)

3. Calculate the total RMS power:

$$P_T = P_{AMP} + P_D \tag{3}$$

The maximum power that the LMH6553 package can dissipate at a given temperature can be derived with the following equation:

$$P_{MAX} = (150^\circ - T_{AMB}) / \theta_{JA}$$

where

- $T_{AMB}$  = Ambient temperature ( $^\circ\text{C}$ )
  - $\theta_{JA}$  = Thermal resistance, from junction to ambient, for a given package ( $^\circ\text{C}/\text{W}$ )
  - For the SO PowerPAD package  $\theta_{JA}$  is  $59^\circ\text{C}/\text{W}$
  - For WSON package  $\theta_{JA}$  is  $58^\circ\text{C}/\text{W}$
- (4)

**Note:** If  $V_{CM}$  is not mid-rail, then there will be quiescent current flowing in the feedback network. This current should be included in the thermal calculations and added into the quiescent power dissipation of the amplifier.

## THERMAL PERFORMANCE

The LMH6553 is available in both the SO PowerPAD and WSON packages. Both packages are designed for enhanced thermal performance and features an exposed die attach pad (DAP) at the bottom center of the package that creates a direct path to the PCB for maximum power dissipation. The DAP is floating and is not electrically connected to internal circuitry.

The thermal advantage of the two packages is fully realized only when the exposed die attach pad is soldered down to a thermal land on the PCB board with thermal vias planted underneath the thermal land. The thermal land can be connected to any power or ground plane within the allowable supply voltage range of the device. The junction-to-ambient thermal resistance ( $\theta_{JA}$ ) of the LMH6553 can be significantly lowered, as opposed to an alternative with no direct soldering to a thermal land. Based on thermal analysis of the WSON package, the junction-to-ambient thermal resistance ( $\theta_{JA}$ ) can be improved by a factor of two when the die attach pad of the WSON package is soldered directly onto the PCB with thermal land and thermal vias are 1.27 mm and 0.33 mm respectively. Typical copper via barrel plating is 1 oz, although thicker copper may be used to further improve thermal performance.

For more information on board layout techniques for the WSON package, refer to Application Note 1187 (literature number [SNOA401](#)). This application note also discusses package handling, solder stencil and the assembly process.

## ESD PROTECTION

The LMH6553 is protected against electrostatic discharge (ESD) on all pins. The LMH6553 will survive 4000V Human Body model and 350V Machine model events. Under normal operation the ESD diodes have no effect on circuit performance. The current that flows through the ESD diodes will either exit the chip through the supply pins or through the device, hence it is possible to power up a chip with a large signal applied to the input pins.

## BOARD LAYOUT

The LMH6553 is a very high performance amplifier. In order to get maximum benefit from the differential circuit architecture, board layout and component selection are very critical. The circuit board should have a low inductance ground plane and well bypassed wide supply lines. External components should be leadless surface mount types. The feedback network and output matching resistors should be composed of short traces and precision resistors (0.1%). The output matching resistors should be placed within 3 or 4 mm of the amplifier as should the supply bypass capacitors. Refer to [POWER SUPPLY BYPASSING](#) for recommendations on bypass circuit layout. Evaluation boards are available free of charge through the product folder on TI's web site.

By design, the LMH6553 is relatively insensitive to parasitic capacitance at its inputs. Nonetheless, ground and power plane metal should be removed from beneath the amplifier and from beneath  $R_F$  and  $R_G$  for best performance at high frequency.

With any differential signal path, symmetry is very important. Even small amounts of asymmetry can contribute to distortion and balance errors.

## EVALUATION BOARD

See the [LMH6553 Product Folder](#) for evaluation board availability and ordering information.

## REVISION HISTORY

Changes from Revision G (March 2013) to Revision H	Page
• Changed layout of National Data Sheet to TI format .....	<a href="#">29</a>

**PACKAGING INFORMATION**

Orderable Device	Status (1)	Package Type	Package Drawing	Pins	Package Qty	Eco Plan (2)	Lead/Ball Finish (6)	MSL Peak Temp (3)	Op Temp (°C)	Device Marking (4/5)	Samples
LMH6553MR/NOPB	ACTIVE	SO PowerPAD	DDA	8	95	Green (RoHS & no Sb/Br)	CU SN	Level-3-260C-168 HR	-40 to 125	LMH65 53MR	<a href="#">Samples</a>
LMH6553MRE/NOPB	ACTIVE	SO PowerPAD	DDA	8	250	Green (RoHS & no Sb/Br)	CU SN	Level-3-260C-168 HR	-40 to 125	LMH65 53MR	<a href="#">Samples</a>
LMH6553MRX/NOPB	ACTIVE	SO PowerPAD	DDA	8	2500	Green (RoHS & no Sb/Br)	CU SN	Level-3-260C-168 HR	-40 to 125	LMH65 53MR	<a href="#">Samples</a>
LMH6553SD/NOPB	ACTIVE	WSON	NGS	8	1000	Green (RoHS & no Sb/Br)	CU SN	Level-1-260C-UNLIM	-40 to 125	6553	<a href="#">Samples</a>
LMH6553SDE/NOPB	ACTIVE	WSON	NGS	8	250	Green (RoHS & no Sb/Br)	CU SN	Level-1-260C-UNLIM	-40 to 125	6553	<a href="#">Samples</a>

(1) The marketing status values are defined as follows:

**ACTIVE:** Product device recommended for new designs.

**LIFEBUY:** TI has announced that the device will be discontinued, and a lifetime-buy period is in effect.

**NRND:** Not recommended for new designs. Device is in production to support existing customers, but TI does not recommend using this part in a new design.

**PREVIEW:** Device has been announced but is not in production. Samples may or may not be available.

**OBSOLETE:** TI has discontinued the production of the device.

(2) Eco Plan - The planned eco-friendly classification: Pb-Free (RoHS), Pb-Free (RoHS Exempt), or Green (RoHS & no Sb/Br) - please check <http://www.ti.com/productcontent> for the latest availability information and additional product content details.

**TBD:** The Pb-Free/Green conversion plan has not been defined.

**Pb-Free (RoHS):** TI's terms "Lead-Free" or "Pb-Free" mean semiconductor products that are compatible with the current RoHS requirements for all 6 substances, including the requirement that lead not exceed 0.1% by weight in homogeneous materials. Where designed to be soldered at high temperatures, TI Pb-Free products are suitable for use in specified lead-free processes.

**Pb-Free (RoHS Exempt):** This component has a RoHS exemption for either 1) lead-based flip-chip solder bumps used between the die and package, or 2) lead-based die adhesive used between the die and leadframe. The component is otherwise considered Pb-Free (RoHS compatible) as defined above.

**Green (RoHS & no Sb/Br):** TI defines "Green" to mean Pb-Free (RoHS compatible), and free of Bromine (Br) and Antimony (Sb) based flame retardants (Br or Sb do not exceed 0.1% by weight in homogeneous material)

(3) MSL, Peak Temp. - The Moisture Sensitivity Level rating according to the JEDEC industry standard classifications, and peak solder temperature.

(4) There may be additional marking, which relates to the logo, the lot trace code information, or the environmental category on the device.

(5) Multiple Device Markings will be inside parentheses. Only one Device Marking contained in parentheses and separated by a "~" will appear on a device. If a line is indented then it is a continuation of the previous line and the two combined represent the entire Device Marking for that device.

<sup>(6)</sup> Lead/Ball Finish - Orderable Devices may have multiple material finish options. Finish options are separated by a vertical ruled line. Lead/Ball Finish values may wrap to two lines if the finish value exceeds the maximum column width.

**Important Information and Disclaimer:**The information provided on this page represents TI's knowledge and belief as of the date that it is provided. TI bases its knowledge and belief on information provided by third parties, and makes no representation or warranty as to the accuracy of such information. Efforts are underway to better integrate information from third parties. TI has taken and continues to take reasonable steps to provide representative and accurate information but may not have conducted destructive testing or chemical analysis on incoming materials and chemicals. TI and TI suppliers consider certain information to be proprietary, and thus CAS numbers and other limited information may not be available for release.

In no event shall TI's liability arising out of such information exceed the total purchase price of the TI part(s) at issue in this document sold by TI to Customer on an annual basis.

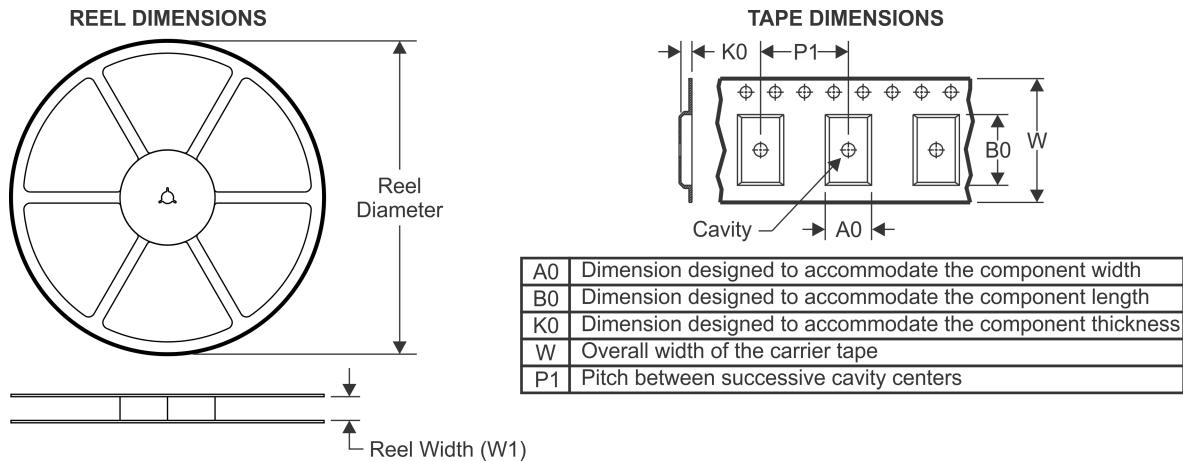

**TAPE AND REEL INFORMATION**

**QUADRANT ASSIGNMENTS FOR PIN 1 ORIENTATION IN TAPE**

\*All dimensions are nominal

Device	Package Type	Package Drawing	Pins	SPQ	Reel Diameter (mm)	Reel Width W1 (mm)	A0 (mm)	B0 (mm)	K0 (mm)	P1 (mm)	W (mm)	Pin1 Quadrant
LMH6553MRE/NOPB	SO Power PAD	DDA	8	250	178.0	12.4	6.5	5.4	2.0	8.0	12.0	Q1
LMH6553MRX/NOPB	SO Power PAD	DDA	8	2500	330.0	12.4	6.5	5.4	2.0	8.0	12.0	Q1
LMH6553SD/NOPB	WSO	NGS	8	1000	178.0	12.4	3.3	2.8	1.0	8.0	12.0	Q1
LMH6553SDE/NOPB	WSO	NGS	8	250	178.0	12.4	3.3	2.8	1.0	8.0	12.0	Q1

**TAPE AND REEL BOX DIMENSIONS**

\*All dimensions are nominal

Device	Package Type	Package Drawing	Pins	SPQ	Length (mm)	Width (mm)	Height (mm)
LMH6553MRE/NOPB	SO PowerPAD	DDA	8	250	213.0	191.0	55.0
LMH6553MRX/NOPB	SO PowerPAD	DDA	8	2500	367.0	367.0	35.0
LMH6553SD/NOPB	WSON	NGS	8	1000	210.0	185.0	35.0
LMH6553SDE/NOPB	WSON	NGS	8	250	210.0	185.0	35.0

DDA (R-PDSO-G8)

PowerPAD™ PLASTIC SMALL OUTLINE

## THERMAL INFORMATION

This PowerPAD™ package incorporates an exposed thermal pad that is designed to be attached to a printed circuit board (PCB). The thermal pad must be soldered directly to the PCB. After soldering, the PCB can be used as a heatsink. In addition, through the use of thermal vias, the thermal pad can be attached directly to the appropriate copper plane shown in the electrical schematic for the device, or alternatively, can be attached to a special heatsink structure designed into the PCB. This design optimizes the heat transfer from the integrated circuit (IC).

For additional information on the PowerPAD package and how to take advantage of its heat dissipating abilities, refer to Technical Brief, PowerPAD Thermally Enhanced Package, Texas Instruments Literature No. SLMA002 and Application Brief, PowerPAD Made Easy, Texas Instruments Literature No. SLMA004. Both documents are available at [www.ti.com](http://www.ti.com).

The exposed thermal pad dimensions for this package are shown in the following illustration.

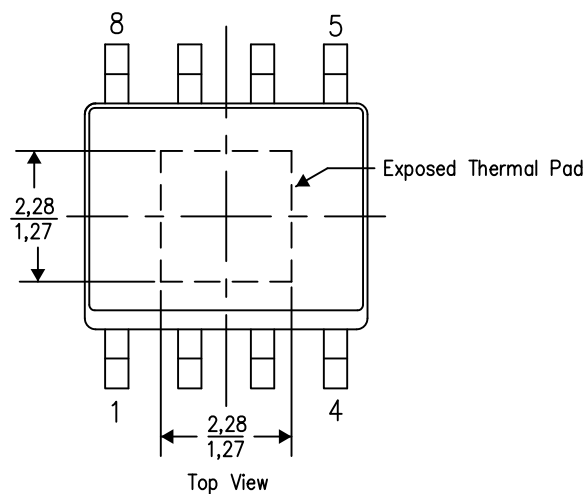

Exposed Thermal Pad Dimensions

4206322-2/L 05/12

NOTE: A. All linear dimensions are in millimeters

PowerPAD is a trademark of Texas Instruments

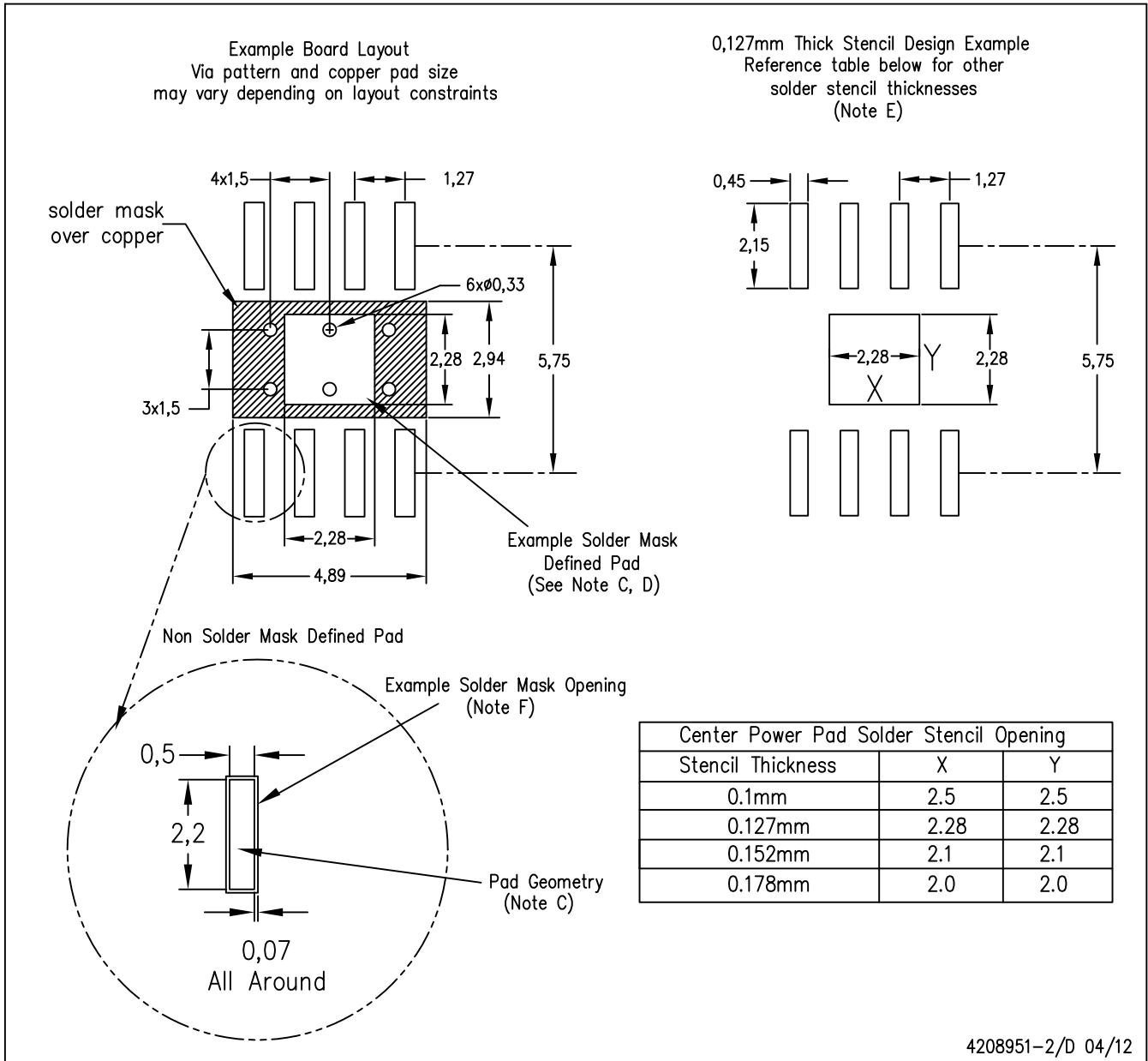

4208951-2/D 04/12

- NOTES:
- A. All linear dimensions are in millimeters.
  - B. This drawing is subject to change without notice.
  - C. Publication IPC-7351 is recommended for alternate designs.
  - D. This package is designed to be soldered to a thermal pad on the board. Refer to Technical Brief, PowerPAD Thermally Enhanced Package, Texas Instruments Literature No. SLMA002, SLMA004, and also the Product Data Sheets for specific thermal information, via requirements, and recommended board layout. These documents are available at [www.ti.com](http://www.ti.com) <<http://www.ti.com>>. Publication IPC-7351 is recommended for alternate designs.
  - E. Laser cutting apertures with trapezoidal walls and also rounding corners will offer better paste release. Customers should contact their board assembly site for stencil design recommendations. Example stencil design based on a 50% volumetric metal load solder paste. Refer to IPC-7525 for other stencil recommendations.
  - F. Customers should contact their board fabrication site for solder mask tolerances between and around signal pads.

PowerPAD is a trademark of Texas Instruments.

# DDA0008A

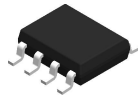

# PACKAGE OUTLINE

## PowerPAD™ SOIC - 1.7 mm max height

PLASTIC SMALL OUTLINE

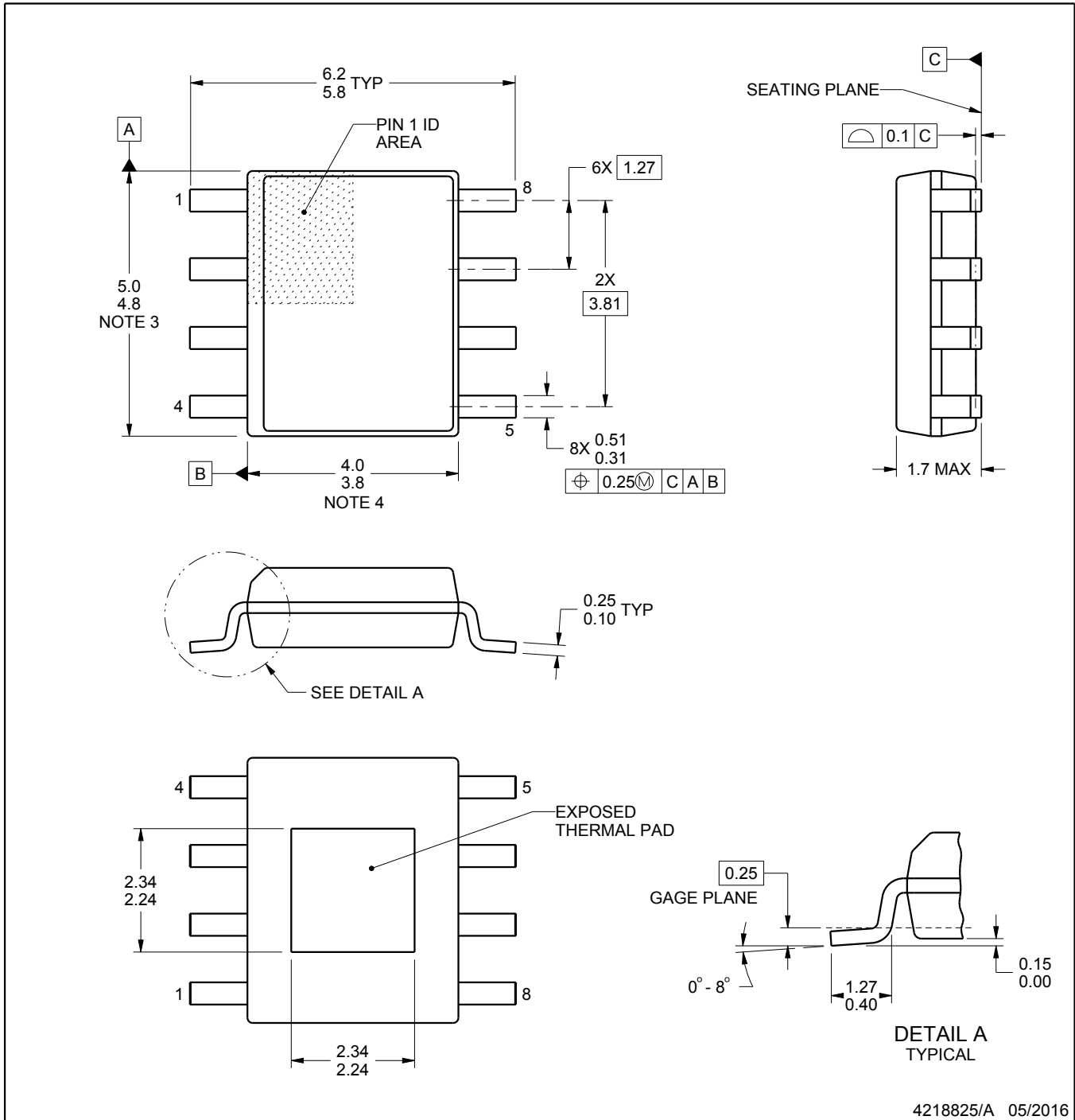

4218825/A 05/2016

PowerPAD is a trademark of Texas Instruments.

### NOTES:

1. All linear dimensions are in millimeters. Any dimensions in parenthesis are for reference only. Dimensioning and tolerancing per ASME Y14.5M.
2. This drawing is subject to change without notice.
3. This dimension does not include mold flash, protrusions, or gate burrs. Mold flash, protrusions, or gate burrs shall not exceed 0.15 mm per side.
4. This dimension does not include interlead flash. Interlead flash shall not exceed 0.25 mm per side.
5. Reference JEDEC registration MS-012.

# EXAMPLE BOARD LAYOUT

DDA0008A

PowerPAD™ SOIC - 1.7 mm max height

PLASTIC SMALL OUTLINE

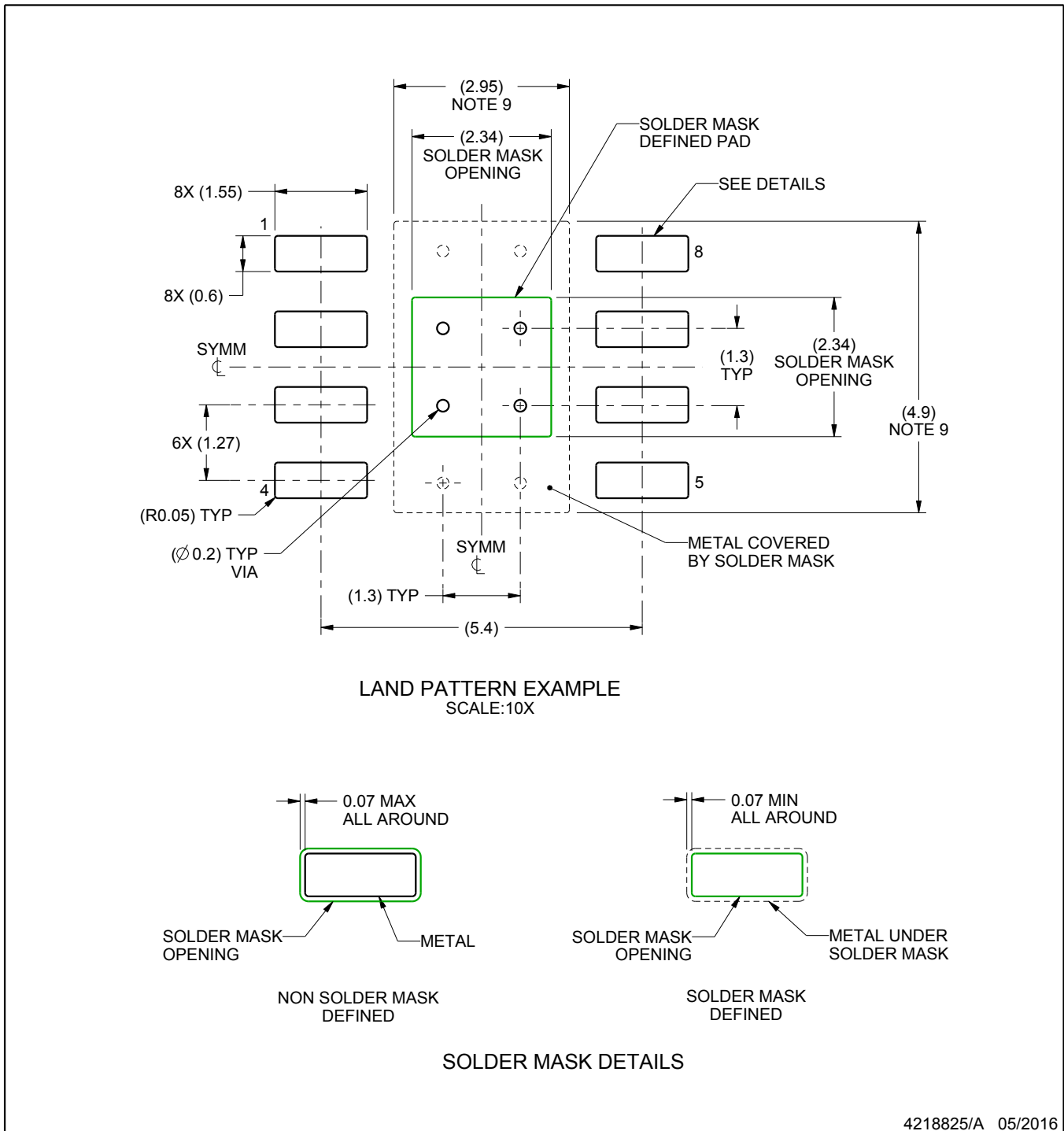

4218825/A 05/2016

NOTES: (continued)

6. Publication IPC-7351 may have alternate designs.
7. Solder mask tolerances between and around signal pads can vary based on board fabrication site.
8. This package is designed to be soldered to a thermal pad on the board. For more information, see Texas Instruments literature numbers SLMA002 ([www.ti.com/lit/slma002](http://www.ti.com/lit/slma002)) and SLMA004 ([www.ti.com/lit/slma004](http://www.ti.com/lit/slma004)).
9. Size of metal pad may vary due to creepage requirement.
10. Vias are optional depending on application, refer to device data sheet. If any vias are implemented, refer to their locations shown on this view. It is recommended that vias under paste be filled, plugged or tented.

# EXAMPLE STENCIL DESIGN

DDA0008A

PowerPAD™ SOIC - 1.7 mm max height

PLASTIC SMALL OUTLINE

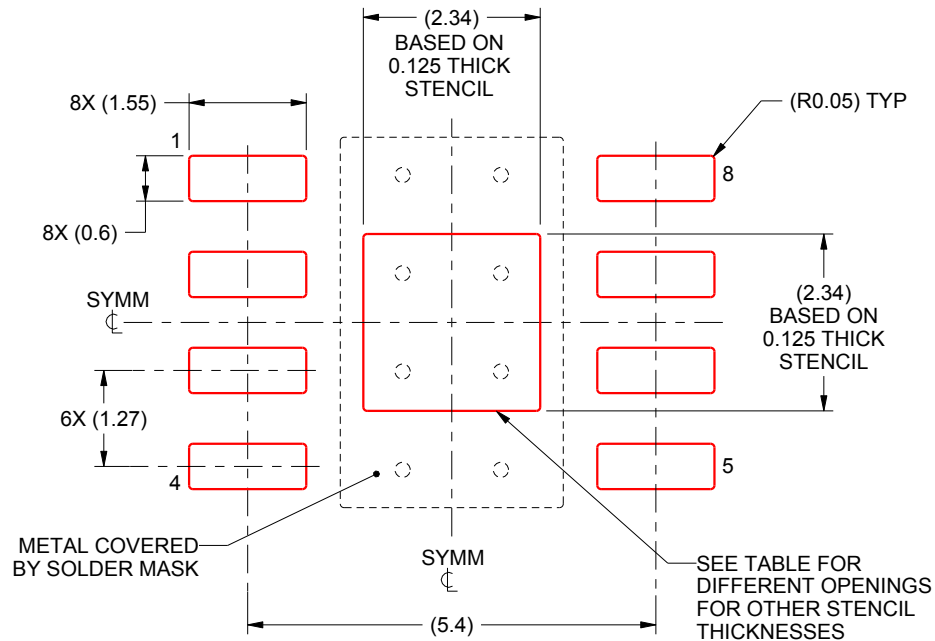

SOLDER PASTE EXAMPLE  
 EXPOSED PAD  
 100% PRINTED SOLDER COVERAGE BY AREA  
 SCALE:10X

STENCIL THICKNESS	SOLDER STENCIL OPENING
0.1	2.62 X 2.62
0.125	2.34 X 2.34 (SHOWN)
0.150	2.14 X 2.14
0.175	1.98 X 1.98

4218825/A 05/2016

NOTES: (continued)

11. Laser cutting apertures with trapezoidal walls and rounded corners may offer better paste release. IPC-7525 may have alternate design recommendations.
12. Board assembly site may have different recommendations for stencil design.

NGS0008C

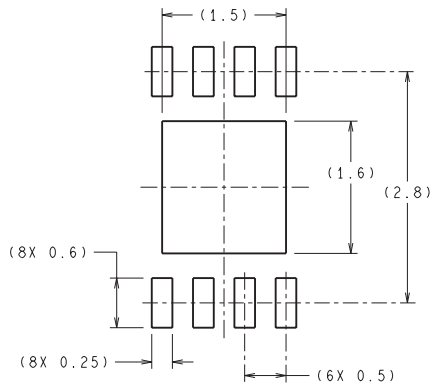

RECOMMENDED LAND PATTERN

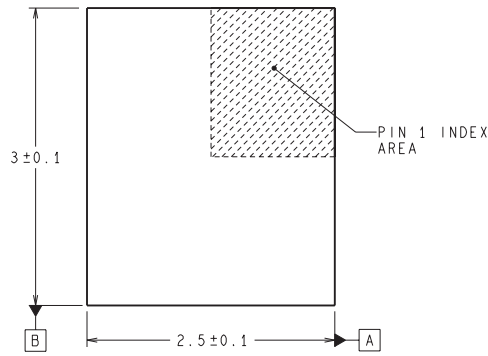

DIMENSIONS ARE IN MILLIMETERS  
DIMENSIONS IN ( ) FOR REFERENCE ONLY

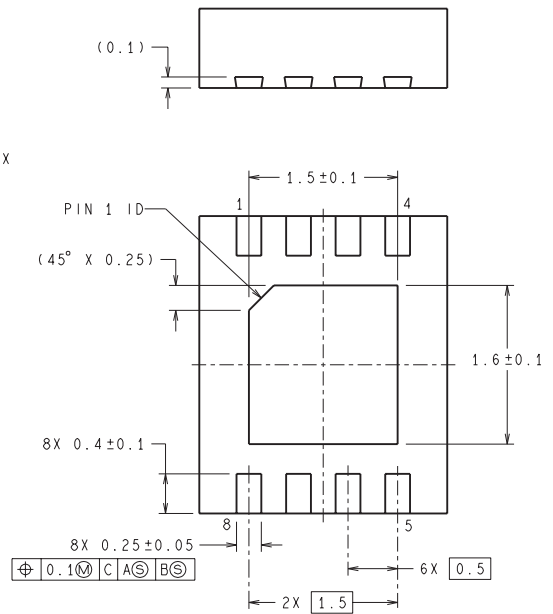
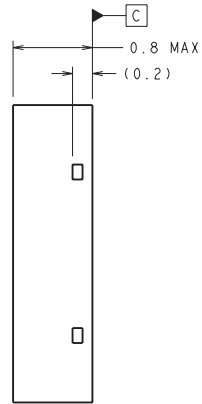

SDA08C (Rev A)



## IMPORTANT NOTICE

Texas Instruments Incorporated and its subsidiaries (TI) reserve the right to make corrections, enhancements, improvements and other changes to its semiconductor products and services per JESD46, latest issue, and to discontinue any product or service per JESD48, latest issue. Buyers should obtain the latest relevant information before placing orders and should verify that such information is current and complete. All semiconductor products (also referred to herein as "components") are sold subject to TI's terms and conditions of sale supplied at the time of order acknowledgment.

TI warrants performance of its components to the specifications applicable at the time of sale, in accordance with the warranty in TI's terms and conditions of sale of semiconductor products. Testing and other quality control techniques are used to the extent TI deems necessary to support this warranty. Except where mandated by applicable law, testing of all parameters of each component is not necessarily performed.

TI assumes no liability for applications assistance or the design of Buyers' products. Buyers are responsible for their products and applications using TI components. To minimize the risks associated with Buyers' products and applications, Buyers should provide adequate design and operating safeguards.

TI does not warrant or represent that any license, either express or implied, is granted under any patent right, copyright, mask work right, or other intellectual property right relating to any combination, machine, or process in which TI components or services are used. Information published by TI regarding third-party products or services does not constitute a license to use such products or services or a warranty or endorsement thereof. Use of such information may require a license from a third party under the patents or other intellectual property of the third party, or a license from TI under the patents or other intellectual property of TI.

Reproduction of significant portions of TI information in TI data books or data sheets is permissible only if reproduction is without alteration and is accompanied by all associated warranties, conditions, limitations, and notices. TI is not responsible or liable for such altered documentation. Information of third parties may be subject to additional restrictions.

Resale of TI components or services with statements different from or beyond the parameters stated by TI for that component or service voids all express and any implied warranties for the associated TI component or service and is an unfair and deceptive business practice. TI is not responsible or liable for any such statements.

Buyer acknowledges and agrees that it is solely responsible for compliance with all legal, regulatory and safety-related requirements concerning its products, and any use of TI components in its applications, notwithstanding any applications-related information or support that may be provided by TI. Buyer represents and agrees that it has all the necessary expertise to create and implement safeguards which anticipate dangerous consequences of failures, monitor failures and their consequences, lessen the likelihood of failures that might cause harm and take appropriate remedial actions. Buyer will fully indemnify TI and its representatives against any damages arising out of the use of any TI components in safety-critical applications.

In some cases, TI components may be promoted specifically to facilitate safety-related applications. With such components, TI's goal is to help enable customers to design and create their own end-product solutions that meet applicable functional safety standards and requirements. Nonetheless, such components are subject to these terms.

No TI components are authorized for use in FDA Class III (or similar life-critical medical equipment) unless authorized officers of the parties have executed a special agreement specifically governing such use.

Only those TI components which TI has specifically designated as military grade or "enhanced plastic" are designed and intended for use in military/aerospace applications or environments. Buyer acknowledges and agrees that any military or aerospace use of TI components which have **not** been so designated is solely at the Buyer's risk, and that Buyer is solely responsible for compliance with all legal and regulatory requirements in connection with such use.

TI has specifically designated certain components as meeting ISO/TS16949 requirements, mainly for automotive use. In any case of use of non-designated products, TI will not be responsible for any failure to meet ISO/TS16949.

### Products

Audio	<a href="http://www.ti.com/audio">www.ti.com/audio</a>
Amplifiers	<a href="http://amplifier.ti.com">amplifier.ti.com</a>
Data Converters	<a href="http://dataconverter.ti.com">dataconverter.ti.com</a>
DLP® Products	<a href="http://www.dlp.com">www.dlp.com</a>
DSP	<a href="http://dsp.ti.com">dsp.ti.com</a>
Clocks and Timers	<a href="http://www.ti.com/clocks">www.ti.com/clocks</a>
Interface	<a href="http://interface.ti.com">interface.ti.com</a>
Logic	<a href="http://logic.ti.com">logic.ti.com</a>
Power Mgmt	<a href="http://power.ti.com">power.ti.com</a>
Microcontrollers	<a href="http://microcontroller.ti.com">microcontroller.ti.com</a>
RFID	<a href="http://www.ti-rfid.com">www.ti-rfid.com</a>
OMAP Applications Processors	<a href="http://www.ti.com/omap">www.ti.com/omap</a>
Wireless Connectivity	<a href="http://www.ti.com/wirelessconnectivity">www.ti.com/wirelessconnectivity</a>

### Applications

Automotive and Transportation	<a href="http://www.ti.com/automotive">www.ti.com/automotive</a>
Communications and Telecom	<a href="http://www.ti.com/communications">www.ti.com/communications</a>
Computers and Peripherals	<a href="http://www.ti.com/computers">www.ti.com/computers</a>
Consumer Electronics	<a href="http://www.ti.com/consumer-apps">www.ti.com/consumer-apps</a>
Energy and Lighting	<a href="http://www.ti.com/energy">www.ti.com/energy</a>
Industrial	<a href="http://www.ti.com/industrial">www.ti.com/industrial</a>
Medical	<a href="http://www.ti.com/medical">www.ti.com/medical</a>
Security	<a href="http://www.ti.com/security">www.ti.com/security</a>
Space, Avionics and Defense	<a href="http://www.ti.com/space-avionics-defense">www.ti.com/space-avionics-defense</a>
Video and Imaging	<a href="http://www.ti.com/video">www.ti.com/video</a>

### TI E2E Community

[e2e.ti.com](http://e2e.ti.com)