

LMH6551 Differential, High Speed Op Amp

Check for Samples: [LMH6551](#)

FEATURES

- 370 MHz –3 dB Bandwidth ($V_{OUT} = 0.5 V_{PP}$)
- 50 MHz 0.1 dB Bandwidth
- 2400 V/ μ s Slew Rate
- 18 ns Settling Time to 0.05%
- –94/–96 dB HD2/HD3 @ 5 MHz

APPLICATIONS

- Differential AD Driver
- Video Over Twisted Pair
- Differential Line Driver
- Single End to Differential Converter
- High Speed Differential Signaling
- IF/RF Amplifier
- SAW Filter Buffer/Driver

Typical Application

DESCRIPTION

The LMHTM6551 is a high performance voltage feedback differential amplifier. The LMH6551 has the high speed and low distortion necessary for driving high performance ADCs as well as the current handling capability to drive signals over balanced transmission lines like CAT 5 data cables. The LMH6551 can handle a wide range of video and data formats.

With external gain set resistors, the LMH6551 can be used at any desired gain. Gain flexibility coupled with high speed makes the LMH6551 suitable for use as an IF amplifier in high performance communications equipment.

The LMH6551 is available in the space saving SOIC and VSSOP packages.

Figure 1. Single Ended to Differential ADC Driver

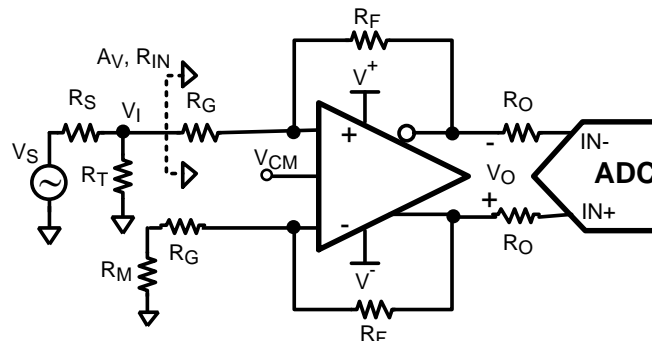

For $R_M \ll R_G$:

$$A_v = \frac{V_O}{V_I} \cong \frac{R_F}{R_G}$$

$$R_{IN} \cong \frac{2R_G(1 + A_v)}{2 + A_v}$$

DesignTarget:

- 1) Set $R_T = \frac{1}{\frac{1}{R_S} - \frac{1}{R_{IN}}}$
- 2) Set $R_M = R_T \parallel R_S$



Please be aware that an important notice concerning availability, standard warranty, and use in critical applications of Texas Instruments semiconductor products and disclaimers thereto appears at the end of this data sheet.

LMH is a trademark of Texas Instruments.

All other trademarks are the property of their respective owners.

Connection Diagram

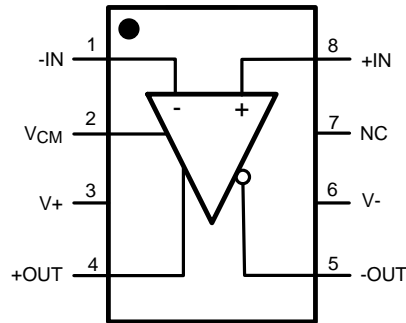

Figure 2. 8-Pin SOIC & VSSOP - Top View
See Package Number D0008A and DGK0008A



These devices have limited built-in ESD protection. The leads should be shorted together or the device placed in conductive foam during storage or handling to prevent electrostatic damage to the MOS gates.

Absolute Maximum Ratings ⁽¹⁾⁽²⁾

ESD Tolerance ⁽³⁾	
Human Body Model	2000V
Machine Model	200V
Supply Voltage	13.2V
Common Mode Input Voltage	±Vs
Maximum Input Current (pins 1, 2, 7, 8)	30mA
Maximum Output Current (pins 4, 5)	⁽⁴⁾
Maximum Junction Temperature	150°C
Soldering Information	
See Product Folder at www.ti.com and SNOA549	

- (1) Absolute Maximum Ratings indicate limits beyond which damage to the device may occur. Operating Ratings indicate conditions for which the device is intended to be functional, but specific performance is not ensured. For ensured specifications, see the Electrical Characteristics tables.
- (2) If Military/Aerospace specified devices are required, please contact the Texas Instruments Sales Office/ Distributors for availability and specifications.
- (3) Human body model: 1.5 kΩ in series with 100 pF. Machine model: 0Ω in series with 200pF.
- (4) The maximum output current (I_{OUT}) is determined by device power dissipation limitations.

Operating Ratings ⁽¹⁾

Operating Temperature Range	-40°C to +125°C
Storage Temperature Range	-65°C to +150°C
Total Supply Voltage	3V to 12V
Package Thermal Resistance (θ _{JA}) ⁽²⁾	
8-Pin VSSOP	235°C/W
8-Pin SOIC	150°C/W

- (1) Absolute Maximum Ratings indicate limits beyond which damage to the device may occur. Operating Ratings indicate conditions for which the device is intended to be functional, but specific performance is not ensured. For ensured specifications, see the Electrical Characteristics tables.
- (2) The maximum power dissipation is a function of T_{J(MAX)}, θ_{JA} and T_A. The maximum allowable power dissipation at any ambient temperature is P_D = (T_{J(MAX)} - T_A) / θ_{JA}. All numbers apply for package soldered directly into a 2 layer PC board with zero air flow.

±5V Electrical Characteristics ⁽¹⁾

Single ended in differential out, $T_A = 25^\circ\text{C}$, $G = +1$, $V_S = \pm 5\text{V}$, $V_{CM} = 0\text{V}$, $R_F = R_G = 365\Omega$, $R_L = 500\Omega$; Unless specified **Boldface** limits apply at the temperature extremes.

Symbol	Parameter	Conditions	Min ⁽²⁾	Typ ⁽³⁾	Max ⁽²⁾	Units
AC Performance (Differential)						
SSBW	Small Signal –3 dB Bandwidth	$V_{OUT} = 0.5 V_{PP}$		370		MHz
LSBW	Large Signal –3 dB Bandwidth	$V_{OUT} = 2 V_{PP}$		340		MHz
	Large Signal –3 dB Bandwidth	$V_{OUT} = 4 V_{PP}$		320		MHz
	0.1 dB Bandwidth	$V_{OUT} = 2 V_{PP}$		50		MHz
	Slew Rate	4V Step ⁽⁴⁾		2400		V/ μs
	Rise/Fall Time	2V Step		1.8		ns
	Settling Time	2V Step, 0.05%		18		ns
V_{CM} Pin AC Performance (Common Mode Feedback Amplifier)						
	Common Mode Small Signal Bandwidth	V_{CM} bypass capacitor removed		200		MHz
Distortion and Noise Response						
HD2		$V_O = 2 V_{PP}$, $f = 5\text{ MHz}$, $R_L = 800\Omega$		-94		dBc
HD2		$V_O = 2 V_{PP}$, $f = 20\text{ MHz}$, $R_L = 800\Omega$		-85		dBc
HD3		$V_O = 2 V_{PP}$, $f = 5\text{ MHz}$, $R_L = 800\Omega$		-96		dBc
HD3		$V_O = 2 V_{PP}$, $f = 20\text{ MHz}$, $R_L = 800\Omega$		-72		dBc
e_n	Input Referred Voltage Noise	Freq $\geq 1\text{ MHz}$		6.0		nV/ $\sqrt{\text{Hz}}$
i_n	Input Referred Noise Current	Freq $\geq 1\text{ MHz}$		1.5		pA/ $\sqrt{\text{Hz}}$
Input Characteristics (Differential)						
V_{OSD}	Input Offset Voltage	Differential Mode, $V_{ID} = 0$, $V_{CM} = 0$		0.5	± 4 ± 6	mV
	Input Offset Voltage Average Temperature Drift	⁽⁵⁾		-0.8		$\mu\text{V}/^\circ\text{C}$
I_{BI}	Input Bias Current	⁽⁶⁾		-4	0 -10	μA
	Input Bias Current Average Temperature Drift	⁽⁵⁾		-2.6		nA/ $^\circ\text{C}$
	Input Bias Difference	Difference in Bias currents between the two inputs		0.03		μA
CMRR	Common Mode Rejection Ratio	DC, $V_{CM} = 0\text{V}$, $V_{ID} = 0\text{V}$	72	80		dBc
R_{IN}	Input Resistance	Differential		5		M Ω
C_{IN}	Input Capacitance	Differential		1		pF
CMVR	Input Common Mode Voltage Range	CMRR > 53dB	+3.1 -4.6	+3.2 -4.7		V
V_{CM} Pin Input Characteristics (Common Mode Feedback Amplifier)						
V_{OSC}	Input Offset Voltage	Common Mode, $V_{ID} = 0$		0.5	± 5 ± 8	mV
	Input Offset Voltage Average Temperature Drift	⁽⁵⁾		8.2		$\mu\text{V}/^\circ\text{C}$
	Input Bias Current	⁽⁶⁾		-2		μA

- (1) Electrical Table values apply only for factory testing conditions at the temperature indicated. Factory testing conditions result in very limited self-heating of the device such that $T_J = T_A$. No specification of parametric performance is indicated in the electrical tables under conditions of internal self-heating where $T_J > T_A$.
- (2) Limits are 100% production tested at 25°C . Limits over the operating temperature range are specified through correlation using Statistical Quality Control (SQC) methods.
- (3) Typical numbers are the most likely parametric norm.
- (4) Slew Rate is the average of the rising and falling edges.
- (5) Drift determined by dividing the change in parameter at temperature extremes by the total temperature change.
- (6) Negative input current implies current flowing out of the device.

±5V Electrical Characteristics ⁽¹⁾ (continued)

Single ended in differential out, $T_A = 25^\circ\text{C}$, $G = +1$, $V_S = \pm 5\text{V}$, $V_{CM} = 0\text{V}$, $R_F = R_G = 365\Omega$, $R_L = 500\Omega$; Unless specified **Boldface** limits apply at the temperature extremes.

Symbol	Parameter	Conditions	Min ⁽²⁾	Typ ⁽³⁾	Max ⁽²⁾	Units
	V_{CM} CMRR	$V_{ID} = 0\text{V}$, 1V step on V_{CM} pin, measure V_{OD}	70	75		dB
	Input Resistance			25		k Ω
	Common Mode Gain	$\Delta V_{O,CM}/\Delta V_{CM}$	0.995	0.999	1.005	V/V
Output Performance						
	Output Voltage Swing	Single Ended, Peak to Peak	± 7.38 ± 7.18	± 7.8		V
	Output Common Mode Voltage Range	$V_{ID} = 0\text{V}$,	± 3.69	± 3.8		V
I_{OUT}	Linear Output Current	$V_{OUT} = 0\text{V}$	± 50	± 65		mA
I_{SC}	Short Circuit Current	Output Shorted to Ground $V_{IN} = 3\text{V}$ Single Ended ⁽⁷⁾		140		mA
	Output Balance Error	ΔV_{OUT} Common Mode $/\Delta V_{OUT}$ Differential, $V_{OUT} = 0.5\text{V}_{pp}$ Differential, $f = 10\text{MHz}$		-70		dB
Miscellaneous Performance						
A_{VOL}	Open Loop Gain	Differential		70		dB
PSRR	Power Supply Rejection Ratio	DC, $\Delta V_S = \pm 1\text{V}$	74	90		dB
	Supply Current	$R_L = \infty$	11	12.5	14.5 16.5	mA

(7) The maximum output current (I_{OUT}) is determined by device power dissipation limitations.

5V Electrical Characteristics ⁽¹⁾

Single ended in differential out, $T_A = 25^\circ\text{C}$, $G = +1$, $V_S = 5\text{V}$, $V_{CM} = 2.5\text{V}$, $R_F = R_G = 365\Omega$, $R_L = 500\Omega$; Unless specified **Boldface** limits apply at the temperature extremes.

Symbol	Parameter	Conditions	Min ⁽²⁾	Typ ⁽³⁾	Max ⁽²⁾	Units
SSBW	Small Signal -3 dB Bandwidth	$R_L = 500\Omega$, $V_{OUT} = 0.5\text{V}_{PP}$		350		MHz
LSBW	Large Signal -3 dB Bandwidth	$R_L = 500\Omega$, $V_{OUT} = 2\text{V}_{PP}$		300		MHz
	0.1 dB Bandwidth	$V_{OUT} = 2\text{V}_{PP}$		50		MHz
	Slew Rate	4V Step ⁽⁴⁾		1800		V/ μs
	Rise/Fall Time, 10% to 90%	4V Step		2		ns
	Settling Time	4V Step, 0.05%		17		ns
V_{CM} Pin AC Performance (Common Mode Feedback Amplifier)						
	Common Mode Small Signal Bandwidth			170		MHz
Distortion and Noise Response						
HD2	2 nd Harmonic Distortion	$V_O = 2\text{V}_{PP}$, $f = 5\text{MHz}$, $R_L = 800\Omega$		-84		dBc
HD2		$V_O = 2\text{V}_{PP}$, $f = 20\text{MHz}$, $R_L = 800\Omega$		-69		dBc
HD3	3 rd Harmonic Distortion	$V_O = 2\text{V}_{PP}$, $f = 5\text{MHz}$, $R_L = 800\Omega$		-93		dBc
HD3		$V_O = 2\text{V}_{PP}$, $f = 20\text{MHz}$, $R_L = 800\Omega$		-67		dBc
e_n	Input Referred Noise Voltage	Freq $\geq 1\text{MHz}$		6.0		nV/ $\sqrt{\text{Hz}}$
i_n	Input Referred Noise Current	Freq $\geq 1\text{MHz}$		1.5		pA/ $\sqrt{\text{Hz}}$

(1) Electrical Table values apply only for factory testing conditions at the temperature indicated. Factory testing conditions result in very limited self-heating of the device such that $T_J = T_A$. No specification of parametric performance is indicated in the electrical tables under conditions of internal self-heating where $T_J > T_A$.

(2) Limits are 100% production tested at 25°C . Limits over the operating temperature range are specified through correlation using Statistical Quality Control (SQC) methods.

(3) Typical numbers are the most likely parametric norm.

(4) Slew Rate is the average of the rising and falling edges.

5V Electrical Characteristics ⁽¹⁾ (continued)

Single ended in differential out, $T_A = 25^\circ\text{C}$, $G = +1$, $V_S = 5\text{V}$, $V_{CM} = 2.5\text{V}$, $R_F = R_G = 365\Omega$, $R_L = 500\Omega$; Unless specified **Boldface** limits apply at the temperature extremes.

Symbol	Parameter	Conditions	Min ⁽²⁾	Typ ⁽³⁾	Max ⁽²⁾	Units
Input Characteristics (Differential)						
V_{OSD}	Input Offset Voltage	Differential Mode, $V_{ID} = 0$, $V_{CM} = 0$		0.5	± 4 ± 6	mV
	Input Offset Voltage Average Temperature Drift	⁽⁵⁾		-0.8		$\mu\text{V}/^\circ\text{C}$
I_{BIAS}	Input Bias Current	⁽⁶⁾		-4	0 -10	μA
	Input Bias Current Average Temperature Drift	⁽⁵⁾		-3		$\text{nA}/^\circ\text{C}$
	Input Bias Current Difference	Difference in Bias currents between the two inputs		0.03		μA
CMRR	Common-Mode Rejection Ratio	DC, $V_{ID} = 0\text{V}$	70	78		dBc
	Input Resistance	Differential		5		$\text{M}\Omega$
	Input Capacitance	Differential		1		pF
V_{ICM}	Input Common Mode Range	CMRR > 53 dB	+3.1 +0.4	+3.2 +0.3		
V_{CM} Pin Input Characteristics (Common Mode Feedback Amplifier)						
	Input Offset Voltage	Common Mode, $V_{ID} = 0$		0.5	± 5 ± 8	mV
	Input Offset Voltage Average Temperature Drift			5.8		$\mu\text{V}/^\circ\text{C}$
	Input Bias Current			3		μA
	V_{CM} CMRR	$V_{ID} = 0$, 1V step on V_{CM} pin, measure V_{OD}	70	75		dB
	Input Resistance	V_{CM} pin to ground		25		$\text{k}\Omega$
	Common Mode Gain	$\Delta V_{O,CM}/\Delta V_{CM}$	0.995	0.991	1.005	V/V
Output Performance						
V_{OUT}	Output Voltage Swing	Single Ended, Peak to Peak, $V_S = \pm 2.5\text{V}$, $V_{CM} = 0\text{V}$	± 2.4	± 2.8		V
I_{OUT}	Linear Output Current	$V_{OUT} = 0\text{V}$ Differential	± 45	± 60		mA
I_{SC}	Output Short Circuit Current	Output Shorted to Ground $V_{IN} = 3\text{V}$ Single Ended ⁽⁷⁾		230		mA
CMVR	Output Common Mode Voltage Range	$V_{ID} = 0$, $V_{CMPin} = 1.2\text{V}$ and 3.8V	3.72 1.23	3.8 1.2		V
	Output Balance Error	$\Delta V_{OUT,CM}$ Common Mode / ΔV_{OUT} Differential, $V_{OUT} = 1\text{Vpp}$ Differential, $f = 10\text{MHz}$		-65		dB
Miscellaneous Performance						
	Open Loop Gain	DC, Differential		70		dB
PSRR	Power Supply Rejection Ratio	DC, $\Delta V_S = \pm 0.5\text{V}$	72	88		dB
I_S	Supply Current	$R_L = \infty$	10	11.5	13.5 15.5	mA

(5) Drift determined by dividing the change in parameter at temperature extremes by the total temperature change.

(6) Negative input current implies current flowing out of the device.

(7) The maximum output current (I_{OUT}) is determined by device power dissipation limitations.

3.3V Electrical Characteristics ⁽¹⁾

Single ended in differential out, $T_A = 25^\circ\text{C}$, $G = +1$, $V_S = 3.3\text{V}$, $V_{CM} = 1.65\text{V}$, $R_F = R_G = 365\Omega$, $R_L = 500\Omega$; Unless specified **Boldface** limits apply at the temperature extremes.

Symbol	Parameter	Conditions	Min ⁽²⁾	Typ ⁽³⁾	Max ⁽²⁾	Units
SSBW	Small Signal -3 dB Bandwidth	$R_L = 500\Omega$, $V_{OUT} = 0.5 V_{PP}$		320		MHz
LSBW	Large Signal -3 dB Bandwidth	$R_L = 500\Omega$, $V_{OUT} = 1 V_{PP}$		300		MHz
	Slew Rate	1V Step ⁽⁴⁾		700		V/ μs
	Rise/Fall Time, 10% to 90%	1V Step		2		ns
V_{CM} Pin AC Performance (Common Mode Feedback Amplifier)						
	Common Mode Small Signal Bandwidth			95		MHz
Distortion and Noise Response						
HD2	2 nd Harmonic Distortion	$V_O = 1 V_{PP}$, $f = 5 \text{ MHz}$, $R_L = 800\Omega$		-93		dBc
HD2		$V_O = 1 V_{PP}$, $f = 20 \text{ MHz}$, $R_L = 800\Omega$		-74		dBc
HD3	3 rd Harmonic Distortion	$V_O = 1 V_{PP}$, $f = 5 \text{ MHz}$, $R_L = 800\Omega$		-85		dBc
HD3		$V_O = 1 V_{PP}$, $f = 20 \text{ MHz}$, $R_L = 800\Omega$		-69		dBc
Input Characteristics (Differential)						
V_{OSD}	Input Offset Voltage	Differential Mode, $V_{ID} = 0$, $V_{CM} = 0$		1		mV
	Input Offset Voltage Average Temperature Drift	⁽⁵⁾		1.6		$\mu\text{V}/^\circ\text{C}$
I_{BIAS}	Input Bias Current	⁽⁶⁾		-8		μA
	Input Bias Current Average Temperature Drift	⁽⁵⁾		9.5		$\text{nA}/^\circ\text{C}$
	Input Bias Current Difference	Difference in Bias currents between the two inputs		0.3		μA
CMRR	Common-Mode Rejection Ratio	DC, $V_{ID} = 0\text{V}$		78		dBc
	Input Resistance	Differential		5		M Ω
	Input Capacitance	Differential		1		pF
V_{ICM}	Input Common Mode Range	CMRR > 53 dB		+1.5 +0.3		
V_{CM} Pin Input Characteristics (Common Mode Feedback Amplifier)						
	Input Offset Voltage	Common Mode, $V_{ID} = 0$		1	± 5	mV
	Input Offset Voltage Average Temperature Drift			18.6		$\mu\text{V}/^\circ\text{C}$
	Input Bias Current			3		μA
	V_{CM} CMRR	$V_{ID} = 0$, 1V step on V_{CM} pin, measure V_{OD}		60		dB
	Input Resistance	V_{CM} pin to ground		25		k Ω
	Common Mode Gain	$\Delta V_{O,CM}/\Delta V_{CM}$		0.999		V/V
Output Performance						
V_{OUT}	Output Voltage Swing	Single Ended, Peak to Peak, $V_S = 3.3\text{V}$, $V_{CM} = 1.65\text{V}$	± 0.75	± 0.9		V
I_{OUT}	Linear Output Current	$V_{OUT} = 0\text{V}$ Differential	± 30	± 40		mA
I_{SC}	Output Short Circuit Current	Output Shorted to Ground $V_{IN} = 2\text{V}$ Single Ended ⁽⁷⁾		200		mA

- (1) Electrical Table values apply only for factory testing conditions at the temperature indicated. Factory testing conditions result in very limited self-heating of the device such that $T_J = T_A$. No specification of parametric performance is indicated in the electrical tables under conditions of internal self-heating where $T_J > T_A$.
- (2) Limits are 100% production tested at 25°C . Limits over the operating temperature range are specified through correlation using Statistical Quality Control (SQC) methods.
- (3) Typical numbers are the most likely parametric norm.
- (4) Slew Rate is the average of the rising and falling edges.
- (5) Drift determined by dividing the change in parameter at temperature extremes by the total temperature change.
- (6) Negative input current implies current flowing out of the device.
- (7) The maximum output current (I_{OUT}) is determined by device power dissipation limitations.

3.3V Electrical Characteristics ⁽¹⁾ (continued)

Single ended in differential out, $T_A = 25^\circ\text{C}$, $G = +1$, $V_S = 3.3\text{V}$, $V_{CM} = 1.65\text{V}$, $R_F = R_G = 365\Omega$, $R_L = 500\Omega$; Unless specified **Boldface** limits apply at the temperature extremes.

Symbol	Parameter	Conditions	Min ⁽²⁾	Typ ⁽³⁾	Max ⁽²⁾	Units
CMVR	Output Common Mode Voltage Range	$V_{ID} = 0$, $V_{CMPin} = 1.2\text{V}$ and 2.1V		2.1 1.2		V
	Output Balance Error	$\Delta V_{OUT\text{Common Mode}} / \Delta V_{OUT\text{Differential}}$, $V_{OUT} = 1\text{Vpp Differential}$, $f = 10\text{ MHz}$		-65		dB
Miscellaneous Performance						
	Open Loop Gain	DC, Differential		70		dB
PSRR	Power Supply Rejection Ratio	DC, $\Delta V_S = \pm 0.5\text{V}$		75		dB
I_S	Supply Current	$R_L = \infty$		8		mA

Typical Performance Characteristics

($T_A = 25^\circ\text{C}$, $V_S = \pm 5\text{V}$, $R_L = 500\Omega$, $R_F = R_G = 365\Omega$; Unless Specified).

Frequency Response vs. Supply Voltage

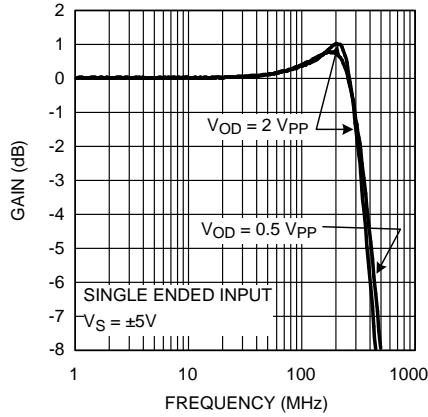

Figure 3.

Frequency Response

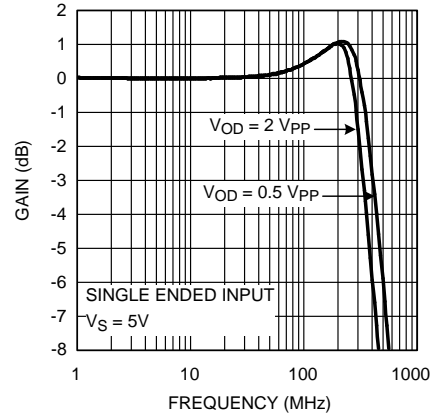

Figure 4.

Frequency Response vs. V_OUT

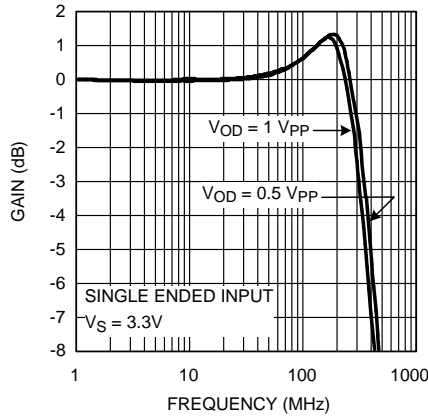

Figure 5.

Frequency Response vs. Capacitive Load

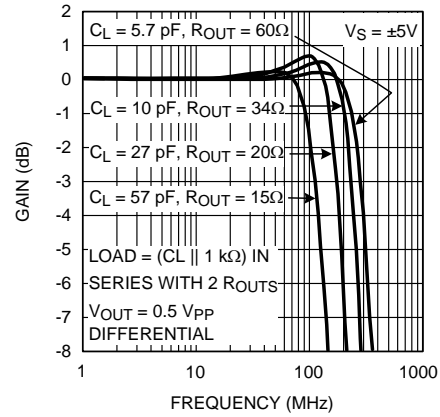

Figure 6.

Suggested R_OUT vs. Cap Load

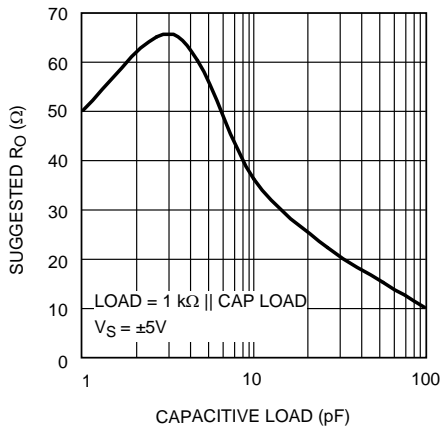

Figure 7.

Suggested R_OUT vs. Cap Load

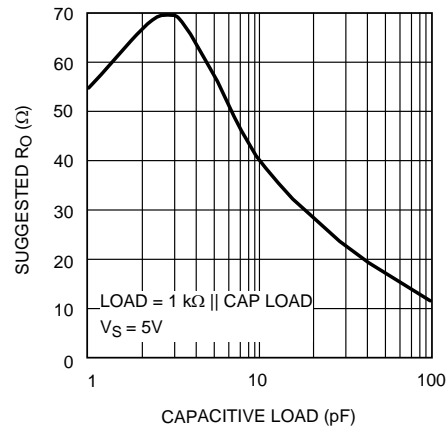

Figure 8.

Typical Performance Characteristics (continued)

($T_A = 25^\circ\text{C}$, $V_S = \pm 5\text{V}$, $R_L = 500\Omega$, $R_F = R_G = 365\Omega$; Unless Specified).

1 V_{PP} Pulse Response Single Ended Input

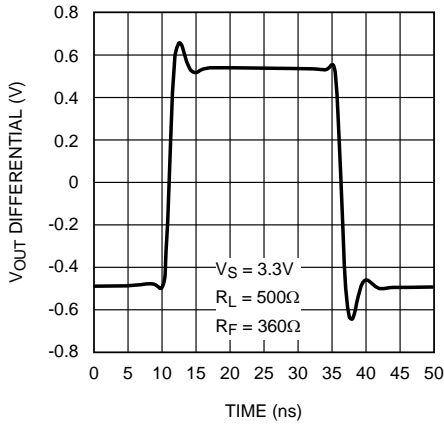

Figure 9.

2 V_{PP} Pulse Response Single Ended Input

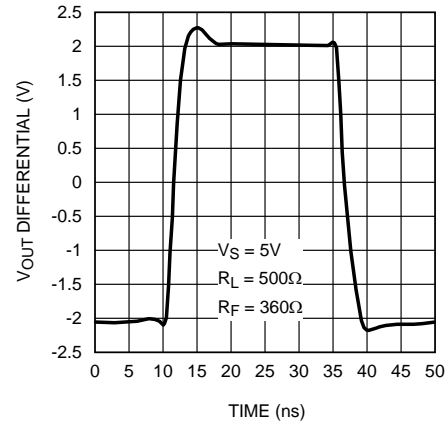

Figure 10.

Large Signal Pulse Response

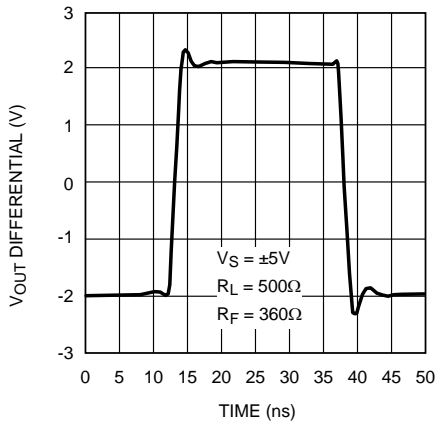

Figure 11.

Output Common Mode Pulse Response

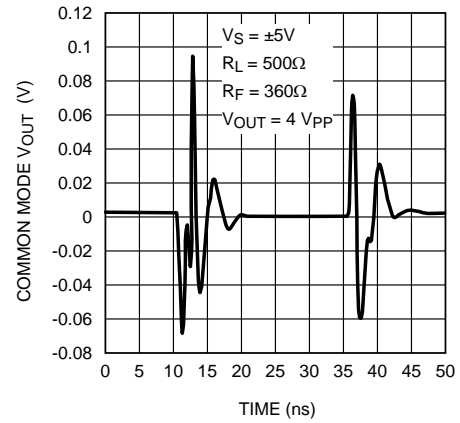

Figure 12.

Distortion vs. Frequency

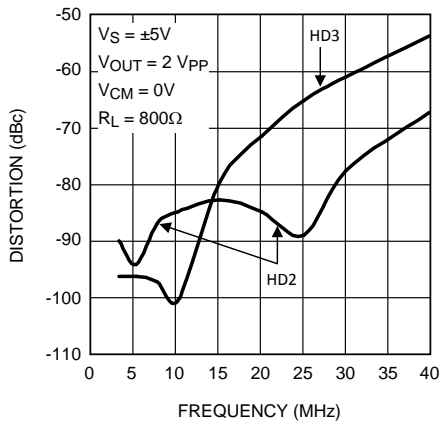

Figure 13.

Distortion vs. Frequency

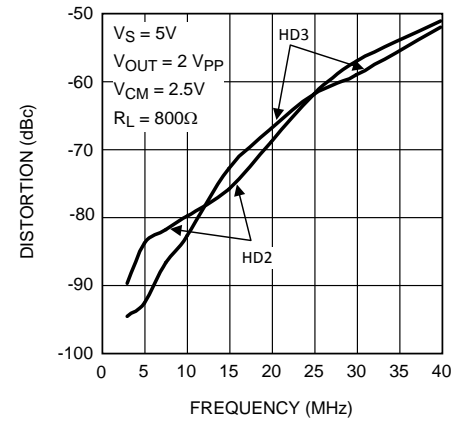

Figure 14.

Typical Performance Characteristics (continued)

($T_A = 25^\circ\text{C}$, $V_S = \pm 5\text{V}$, $R_L = 500\Omega$, $R_F = R_G = 365\Omega$; Unless Specified).

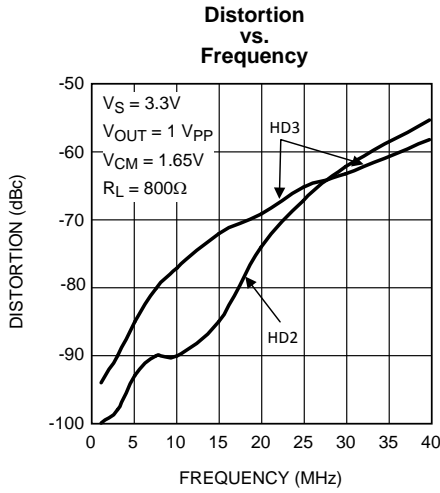

Figure 15.

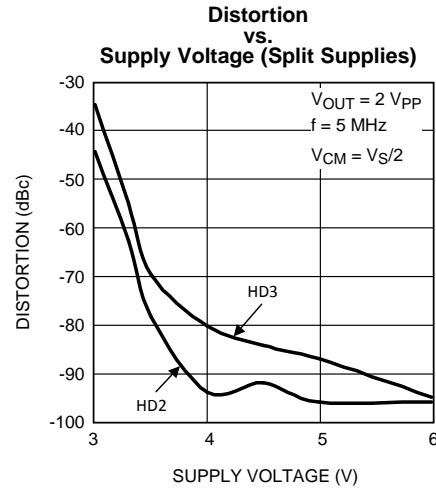

Figure 16.

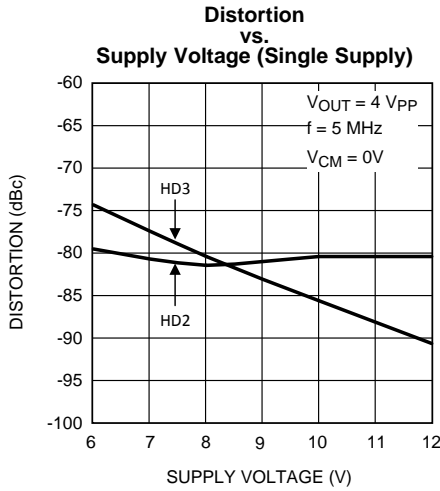

Figure 17.

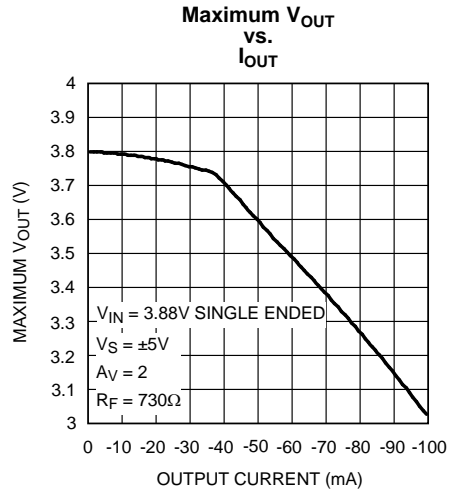

Figure 18.

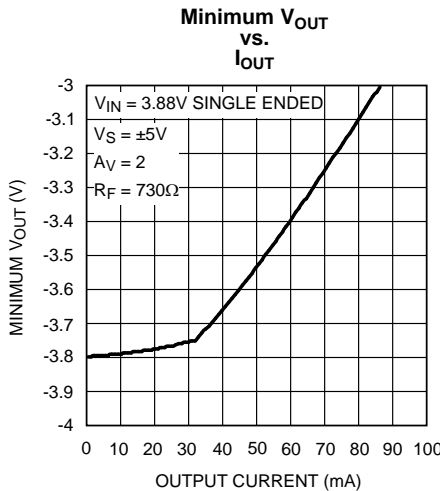

Figure 19.

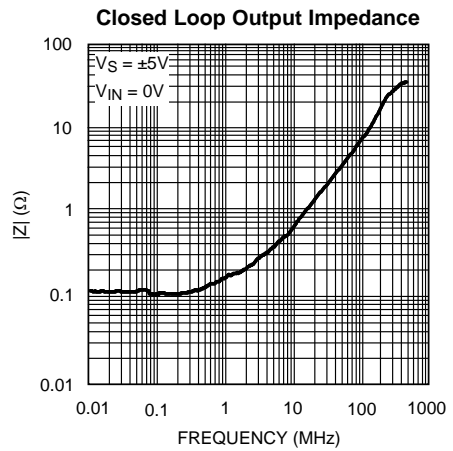

Figure 20.

Typical Performance Characteristics (continued)

($T_A = 25^\circ\text{C}$, $V_S = \pm 5\text{V}$, $R_L = 500\Omega$, $R_F = R_G = 365\Omega$; Unless Specified).

Closed Loop Output Impedance

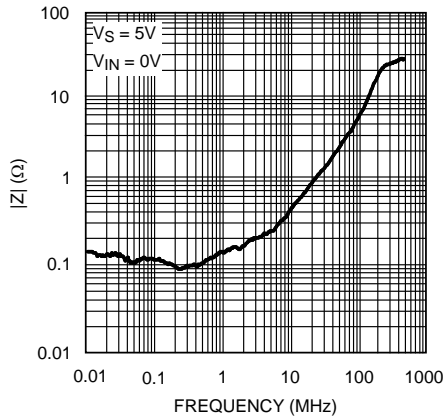

Figure 21.

Closed Loop Output Impedance

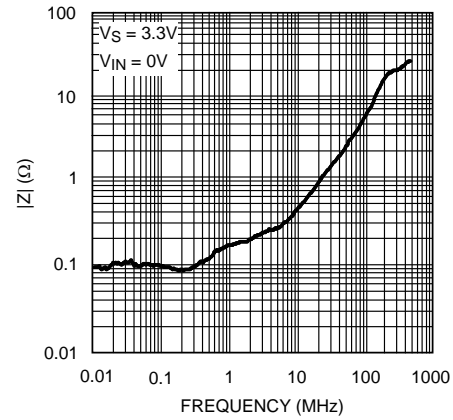

Figure 22.

PSRR

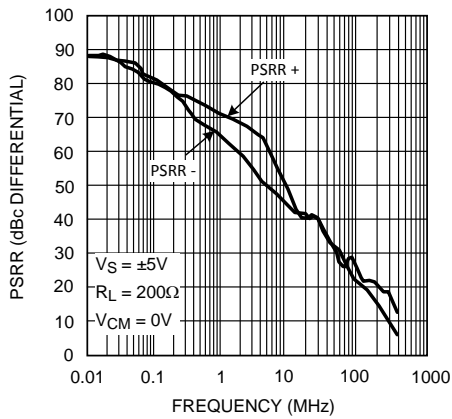

Figure 23.

PSRR

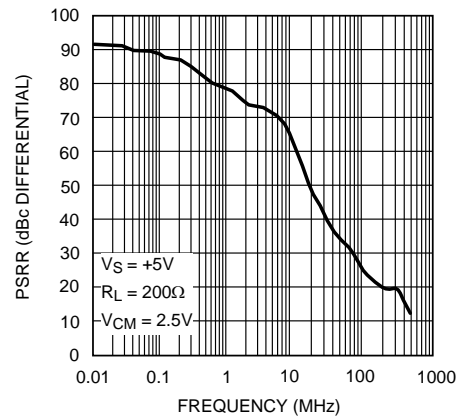

Figure 24.

CMRR

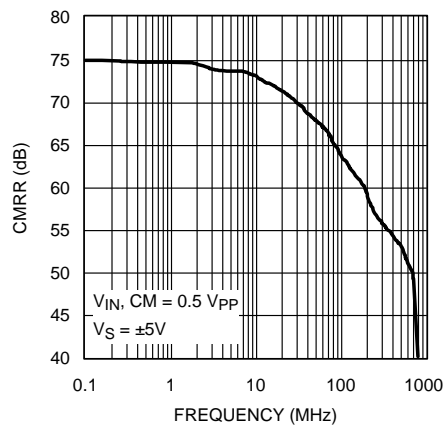

Figure 25.

Balance Error

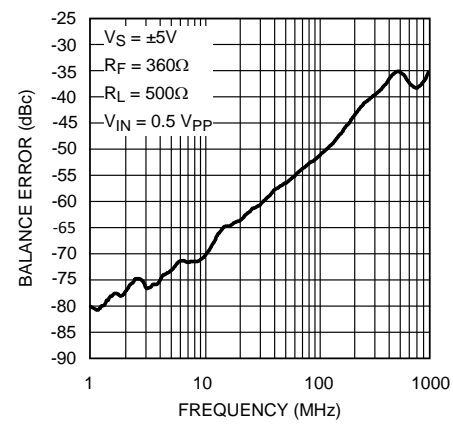

Figure 26.

APPLICATION SECTION

The LMH6551 is a fully differential amplifier designed to provide low distortion amplification to wide bandwidth differential signals. The LMH6551, though fully integrated for ultimate balance and distortion performance, functionally provides three channels. Two of these channels are the V^+ and V^- signal path channels, which function similarly to inverting mode operational amplifiers and are the primary signal paths. The third channel is the common mode feedback circuit. This is the circuit that sets the output common mode as well as driving the V^+ and V^- outputs to be equal magnitude and opposite phase, even when only one of the two input channels is driven. The common mode feedback circuit allows single ended to differential operation.

The LMH6551 is a voltage feedback amplifier with gain set by external resistors. Output common mode voltage is set by the V_{CM} pin. This pin should be driven by a low impedance reference and should be bypassed to ground with a 0.1 μF ceramic capacitor. Any signal coupling into the V_{CM} will be passed along to the output and will reduce the dynamic range of the amplifier.

FULLY DIFFERENTIAL OPERATION

The LMH6551 will perform best when used with split supplies and in a fully differential configuration. See [Figure 27](#) and [Figure 28](#) for recommend circuits.

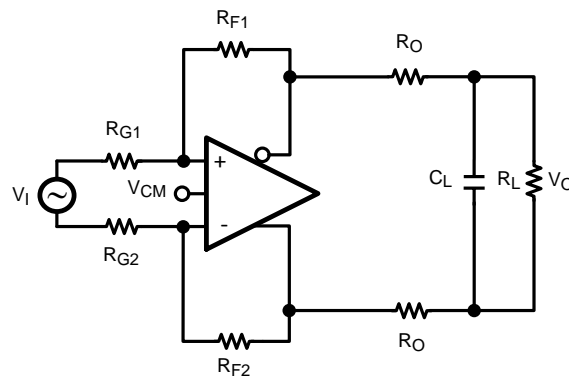

Figure 27. Typical Application

The circuit shown in [Figure 27](#) is a typical fully differential application as might be used to drive an ADC. In this circuit closed loop gain, $(A_V) = V_{OUT}/V_{IN} = R_F/R_G$. For all the applications in this data sheet V_{IN} is presumed to be the voltage presented to the circuit by the signal source. For differential signals this will be the difference of the signals on each input (which will be double the magnitude of each individual signal), while in single ended inputs it will just be the driven input signal.

The resistors R_O help keep the amplifier stable when presented with a load C_L as is typical in an analog to digital converter (ADC). When fed with a differential signal, the LMH6551 provides excellent distortion, balance and common mode rejection provided the resistors R_F , R_G and R_O are well matched and strict symmetry is observed in board layout. With a DC CMRR of over 80dB, the DC and low frequency CMRR of most circuits will be dominated by the external resistors and board trace resistance. At higher frequencies board layout symmetry becomes a factor as well. Precision resistors of at least 0.1% accuracy are recommended and careful board layout will also be required.

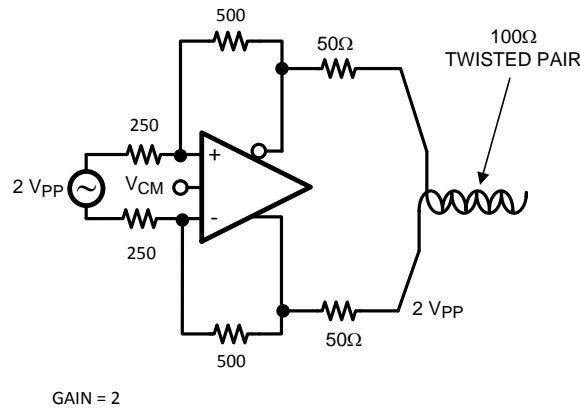

Figure 28. Fully Differential Cable Driver

With up to 15 V_{PP} differential output voltage swing and 80 mA of linear drive current the LMH6551 makes an excellent cable driver as shown in Figure 28. The LMH6551 is also suitable for driving differential cables from a single ended source.

The LMH6551 requires supply bypassing capacitors as shown in Figure 29 and Figure 30. The 0.01 μF and 0.1 μF capacitors should be leadless SMT ceramic capacitors and should be no more than 3 mm from the supply pins. The SMT capacitors should be connected directly to a ground plane. Thin traces or small vias will reduce the effectiveness of bypass capacitors. Also shown in both figures is a capacitor from the V_{CM} pin to ground. The V_{CM} pin is a high impedance input to a buffer which sets the output common mode voltage. Any noise on this input is transferred directly to the output. Output common mode noise will result in loss of dynamic range, degraded CMRR, degraded Balance and higher distortion. The V_{CM} pin should be bypassed even if the pin is not used. There is an internal resistive divider on chip to set the output common mode voltage to the mid point of the supply pins. The impedance looking into this pin is approximately 25 kΩ. If a different output common mode voltage is desired drive this pin with a clean, accurate voltage reference.

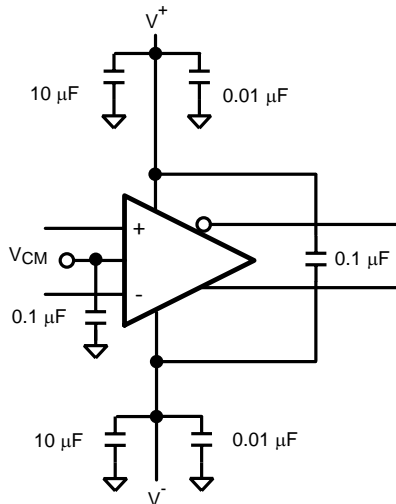

Figure 29. Split Supply Bypassing Capacitors

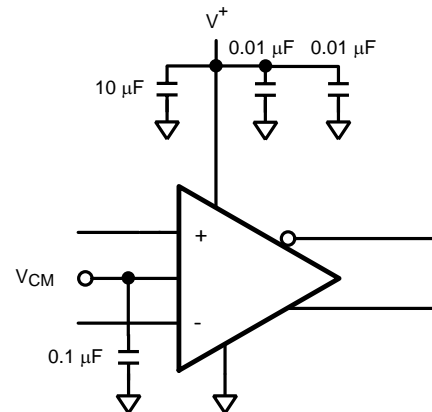
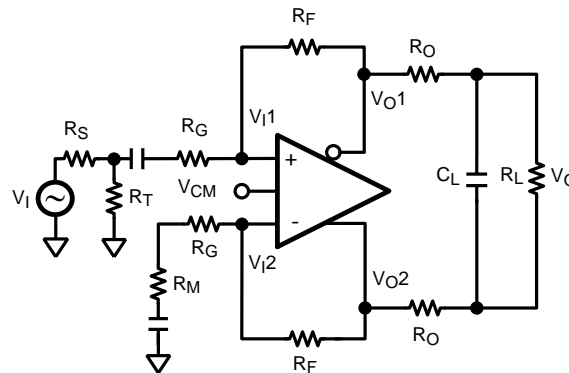

Figure 30. Single Supply Bypassing Capacitors

In Figure 31 closed loop gain = $V_O / V_I \cong R_F / R_G$, where $V_I = V_S / 2$, as long as $R_M \ll R_G$. Note that in single ended to differential operation V_I is measured single ended while V_O is measured differentially. This means that gain is really 1/2 or 6 dB less when measured on either of the output pins separately. Additionally, note that the input signal at R_T (labeled as V_I) is 1/2 of V_S when R_T is chosen to match R_S to R_{IN} .

$V_{ICM} =$ Input common mode voltage = $(V_{I1} + V_{I2}) / 2$.



$$*V_{CM} = \frac{V_{O1} + V_{O2}}{2} \quad *BY\ DESIGN$$

$$V_{ICM} = V_{OCM}$$

$$V_{ICM} = \frac{V_{I1} + V_{I2}}{2}$$

Figure 32. AC Coupled for Single Supply Operation

DRIVING ANALOG TO DIGITAL CONVERTERS

Analog to digital converters (ADC) present challenging load conditions. They typically have high impedance inputs with large and often variable capacitive components. As well, there are usually current spikes associated with switched capacitor or sample and hold circuits. Figure 33 shows a typical circuit for driving an ADC. The two 56Ω resistors serve to isolate the capacitive loading of the ADC from the amplifier and ensure stability. In addition, the resistors form part of a low pass filter which helps to provide anti alias and noise reduction functions. The two 39 pF capacitors help to smooth the current spikes associated with the internal switching circuits of the ADC and also are a key component in the low pass filtering of the ADC input. In the circuit of Figure 33 the cutoff frequency of the filter is $1 / (2 * \pi * 56\Omega * (39\text{ pF} + 14\text{ pF})) = 53\text{ MHz}$ (which is slightly less than the sampling frequency). Note that the ADC input capacitance must be factored into the frequency response of the input filter, and that being a differential input the effective input capacitance is double. Also as shown in Figure 33 the input capacitance to many ADCs is variable based on the clock cycle. See the data sheet for your particular ADC for details.

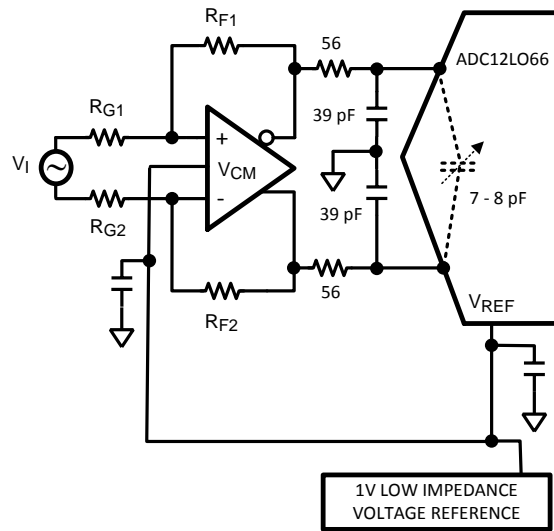

Figure 33. Driving an ADC

The amplifier and ADC should be located as closely together as possible. Both devices require that the filter components be in close proximity to them. The amplifier needs to have minimal parasitic loading on the output traces and the ADC is sensitive to high frequency noise that may couple in on its input lines. Some high performance ADCs have an input stage that has a bandwidth of several times its sample rate. The sampling process results in all input signals presented to the input stage mixing down into the Nyquist range (DC to $F_s/2$). See [AN-236](#) for more details on the subsampling process and the requirements this imposes on the filtering necessary in your system.

USING TRANSFORMERS

Transformers are useful for impedance transformation as well as for single to differential, and differential to single ended conversion. A transformer can be used to step up the output voltage of the amplifier to drive very high impedance loads as shown in [Figure 34](#). [Figure 36](#) shows the opposite case where the output voltage is stepped down to drive a low impedance load.

Transformers have limitations that must be considered before choosing to use one. Compared to a differential amplifier, the most serious limitations of a transformer are the inability to pass DC and balance error (which causes distortion and gain errors). For most applications the LMH6551 will have adequate output swing and drive current and a transformer will not be desirable. Transformers are used primarily to interface differential circuits to 50Ω single ended test equipment to simplify diagnostic testing.

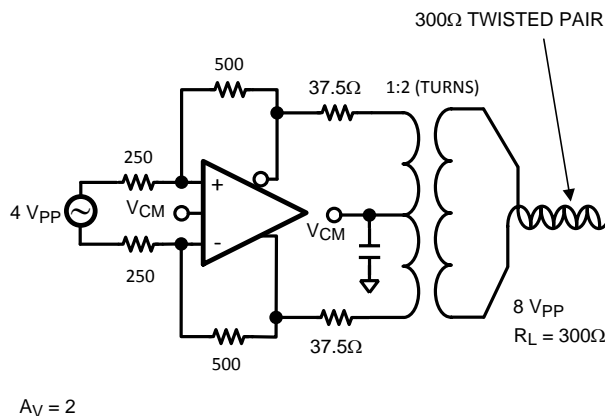

$A_V = 2$

Figure 34. Transformer Out High Impedance Load

$$V_L = \frac{V_{IN} * A_V * N}{\left(\frac{2 R_{OUT} * N^2}{R_L} + 1 \right)}$$

WHERE V_{IN} = DIFFERENTIAL INPUT VOLTAGE

N = TRANSFORMER TURNS RATIO = $\left(\frac{\text{SECONDARY}}{\text{PRIMARY}} \right)$

A_V = CLOSED LOOP AMPLIFIER GAIN

R_{OUT} = SERIES OUTPUT MATCHING RESISTOR

R_L = LOAD RESISTOR

V_L = VOLTAGE ACROSS LOAD RESISTOR

Figure 35. Calculating Transformer Circuit Net Gain

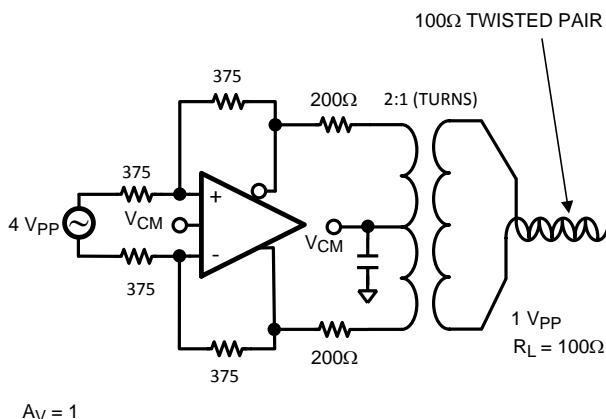

Figure 36. Transformer Out Low Impedance Load

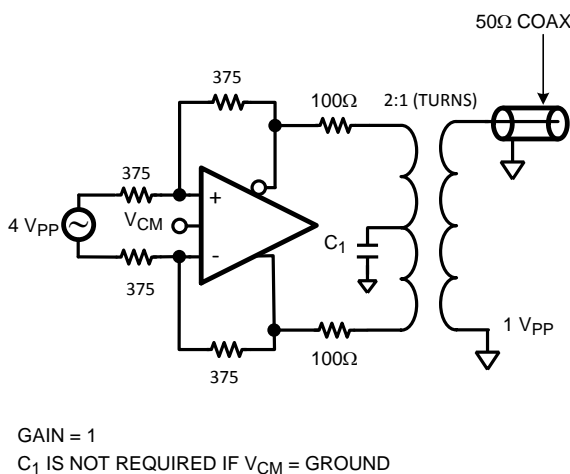

Figure 37. Driving 50Ω Test Equipment

CAPACITIVE DRIVE

As noted in [DRIVING ANALOG TO DIGITAL CONVERTERS](#), capacitive loads should be isolated from the amplifier output with small valued resistors. This is particularly the case when the load has a resistive component that is 500Ω or higher. A typical ADC has capacitive components of around 10 pF and the resistive component could be 1000Ω or higher. If driving a transmission line, such as 50Ω coaxial or 100Ω twisted pair, using matching resistors will be sufficient to isolate any subsequent capacitance. For other applications see [Figure 7](#) and [Figure 8](#) in [Typical Performance Characteristics](#).

POWER DISSIPATION

The LMH6551 is optimized for maximum speed and performance in the small form factor of the standard SOIC package, and is essentially a dual channel amplifier. To ensure maximum output drive and highest performance, thermal shutdown is not provided. Therefore, it is of utmost importance to make sure that the T_{JMAX} of 150°C is never exceeded due to the overall power dissipation.

Follow these steps to determine the Maximum power dissipation for the LMH6551:

1. Calculate the quiescent (no-load) power:

$$P_{AMP} = I_{CC} * (V_S)$$

where

- $V_S = V^+ - V^-$ (1)

Be sure to include any current through the feedback network if V_{OCM} is not mid rail.

2. Calculate the RMS power dissipated in each of the output stages:

$$P_D (rms) = rms ((V_S - V_{OUT}^+) * I_{OUT}^+) + rms ((V_S - V_{OUT}^-) * I_{OUT}^-)$$

where

- V_{OUT} and I_{OUT} are the voltage and the current measured at the output pins of the differential amplifier as if they were single ended amplifiers and V_S is the total supply voltage (2)

3. Calculate the total RMS power:

$$P_T = P_{AMP} + P_D (3)$$

The maximum power that the LMH6551 package can dissipate at a given temperature can be derived with the following equation:

$$P_{MAX} = (150^\circ - T_{AMB}) / \theta_{JA}$$

where

- T_{AMB} = Ambient temperature ($^\circ\text{C}$)
- θ_{JA} = Thermal resistance, from junction to ambient, for a given package ($^\circ\text{C}/\text{W}$)
- For the SOIC package θ_{JA} is $150^\circ\text{C}/\text{W}$. (4)

NOTE

If V_{CM} is not 0V then there will be quiescent current flowing in the feedback network. This current should be included in the thermal calculations and added into the quiescent power dissipation of the amplifier.

ESD PROTECTION

The LMH6551 is protected against electrostatic discharge (ESD) on all pins. The LMH6551 will survive 2000V Human Body model and 200V Machine model events. Under normal operation the ESD diodes have no effect on circuit performance. There are occasions, however, when the ESD diodes will be evident. If the LMH6551 is driven by a large signal while the device is powered down the ESD diodes will conduct. The current that flows through the ESD diodes will either exit the chip through the supply pins or will flow through the device, hence it is possible to power up a chip with a large signal applied to the input pins.

BOARD LAYOUT

The LMH6551 is a very high performance amplifier. In order to get maximum benefit from the differential circuit architecture board layout and component selection is very critical. The circuit board should have a low inductance ground plane and well bypassed broad supply lines. External components should be leadless surface mount types. The feedback network and output matching resistors should be composed of short traces and precision resistors (0.1%). The output matching resistors should be placed within 3-4 mm of the amplifier as should the supply bypass capacitors. The LMH730154 evaluation board is an example of good layout techniques.

The LMH6551 is sensitive to parasitic capacitances on the amplifier inputs and to a lesser extent on the outputs as well. Ground and power plane metal should be removed from beneath the amplifier and from beneath R_F and R_G .

With any differential signal path symmetry is very important. Even small amounts of asymmetry will contribute to distortion and balance errors.

EVALUATION BOARD

Texas Instruments offers evaluation board(s) to aid in device testing and characterization and as a guide for proper layout. Generally, a good high frequency layout will keep power supply and ground traces away from the inverting input and output pins. Parasitic capacitances on these nodes to ground will cause frequency response peaking and possible circuit oscillations (see [Application Note OA-15](#) for more information).

REVISION HISTORY

Changes from Revision B (March 2013) to Revision C	Page
<hr/> <ul style="list-style-type: none">• Changed layout of National Data Sheet to TI format	<hr/> 20

PACKAGING INFORMATION

Orderable Device	Status (1)	Package Type	Package Drawing	Pins	Package Qty	Eco Plan (2)	Lead/Ball Finish	MSL Peak Temp (3)	Op Temp (°C)	Top-Side Markings (4)	Samples
LMH6551MA	ACTIVE	SOIC	D	8	95	TBD	Call TI	Call TI	-40 to 85	LMH6551MA	Samples
LMH6551MA/NOPB	ACTIVE	SOIC	D	8	95	Green (RoHS & no Sb/Br)	CU SN	Level-1-260C-UNLIM	-40 to 85	LMH6551MA	Samples
LMH6551MAX	ACTIVE	SOIC	D	8	2500	TBD	Call TI	Call TI	-40 to 85	LMH6551MAX	Samples
LMH6551MAX/NOPB	ACTIVE	SOIC	D	8	2500	Green (RoHS & no Sb/Br)	CU SN	Level-1-260C-UNLIM	-40 to 85	LMH6551MAX	Samples
LMH6551MM	ACTIVE	VSSOP	DGK	8	1000	TBD	Call TI	Call TI	-40 to 85	AU1A	Samples
LMH6551MM/NOPB	ACTIVE	VSSOP	DGK	8	1000	Green (RoHS & no Sb/Br)	CU SN	Level-1-260C-UNLIM	-40 to 85	AU1A	Samples
LMH6551MMX	ACTIVE	VSSOP	DGK	8	3500	TBD	Call TI	Call TI	-40 to 85	AU1A	Samples
LMH6551MMX/NOPB	ACTIVE	VSSOP	DGK	8	3500	Green (RoHS & no Sb/Br)	CU SN	Level-1-260C-UNLIM	-40 to 85	AU1A	Samples

(1) The marketing status values are defined as follows:

ACTIVE: Product device recommended for new designs.

LIFEBUY: TI has announced that the device will be discontinued, and a lifetime-buy period is in effect.

NRND: Not recommended for new designs. Device is in production to support existing customers, but TI does not recommend using this part in a new design.

PREVIEW: Device has been announced but is not in production. Samples may or may not be available.

OBSOLETE: TI has discontinued the production of the device.

(2) Eco Plan - The planned eco-friendly classification: Pb-Free (RoHS), Pb-Free (RoHS Exempt), or Green (RoHS & no Sb/Br) - please check <http://www.ti.com/productcontent> for the latest availability information and additional product content details.

TBD: The Pb-Free/Green conversion plan has not been defined.

Pb-Free (RoHS): TI's terms "Lead-Free" or "Pb-Free" mean semiconductor products that are compatible with the current RoHS requirements for all 6 substances, including the requirement that lead not exceed 0.1% by weight in homogeneous materials. Where designed to be soldered at high temperatures, TI Pb-Free products are suitable for use in specified lead-free processes.

Pb-Free (RoHS Exempt): This component has a RoHS exemption for either 1) lead-based flip-chip solder bumps used between the die and package, or 2) lead-based die adhesive used between the die and leadframe. The component is otherwise considered Pb-Free (RoHS compatible) as defined above.

Green (RoHS & no Sb/Br): TI defines "Green" to mean Pb-Free (RoHS compatible), and free of Bromine (Br) and Antimony (Sb) based flame retardants (Br or Sb do not exceed 0.1% by weight in homogeneous material)

(3) MSL, Peak Temp. -- The Moisture Sensitivity Level rating according to the JEDEC industry standard classifications, and peak solder temperature.

⁽⁴⁾ Multiple Top-Side Markings will be inside parentheses. Only one Top-Side Marking contained in parentheses and separated by a "~" will appear on a device. If a line is indented then it is a continuation of the previous line and the two combined represent the entire Top-Side Marking for that device.

Important Information and Disclaimer: The information provided on this page represents TI's knowledge and belief as of the date that it is provided. TI bases its knowledge and belief on information provided by third parties, and makes no representation or warranty as to the accuracy of such information. Efforts are underway to better integrate information from third parties. TI has taken and continues to take reasonable steps to provide representative and accurate information but may not have conducted destructive testing or chemical analysis on incoming materials and chemicals. TI and TI suppliers consider certain information to be proprietary, and thus CAS numbers and other limited information may not be available for release.

In no event shall TI's liability arising out of such information exceed the total purchase price of the TI part(s) at issue in this document sold by TI to Customer on an annual basis.

TAPE AND REEL INFORMATION



QUADRANT ASSIGNMENTS FOR PIN 1 ORIENTATION IN TAPE



*All dimensions are nominal

Device	Package Type	Package Drawing	Pins	SPQ	Reel Diameter (mm)	Reel Width W1 (mm)	A0 (mm)	B0 (mm)	K0 (mm)	P1 (mm)	W (mm)	Pin1 Quadrant
LMH6551MAX	SOIC	D	8	2500	330.0	12.4	6.5	5.4	2.0	8.0	12.0	Q1
LMH6551MAX/NOPB	SOIC	D	8	2500	330.0	12.4	6.5	5.4	2.0	8.0	12.0	Q1
LMH6551MM	VSSOP	DGK	8	1000	178.0	12.4	5.3	3.4	1.4	8.0	12.0	Q1
LMH6551MM/NOPB	VSSOP	DGK	8	1000	178.0	12.4	5.3	3.4	1.4	8.0	12.0	Q1
LMH6551MMX	VSSOP	DGK	8	3500	330.0	12.4	5.3	3.4	1.4	8.0	12.0	Q1
LMH6551MMX/NOPB	VSSOP	DGK	8	3500	330.0	12.4	5.3	3.4	1.4	8.0	12.0	Q1

TAPE AND REEL BOX DIMENSIONS

*All dimensions are nominal

Device	Package Type	Package Drawing	Pins	SPQ	Length (mm)	Width (mm)	Height (mm)
LMH6551MAX	SOIC	D	8	2500	367.0	367.0	35.0
LMH6551MAX/NOPB	SOIC	D	8	2500	367.0	367.0	35.0
LMH6551MM	VSSOP	DGK	8	1000	210.0	185.0	35.0
LMH6551MM/NOPB	VSSOP	DGK	8	1000	210.0	185.0	35.0
LMH6551MMX	VSSOP	DGK	8	3500	367.0	367.0	35.0
LMH6551MMX/NOPB	VSSOP	DGK	8	3500	367.0	367.0	35.0

DGK (S-PDSO-G8)

PLASTIC SMALL-OUTLINE PACKAGE



- NOTES:
- A. All linear dimensions are in millimeters.
 - B. This drawing is subject to change without notice.
 - C. Body length does not include mold flash, protrusions, or gate burrs. Mold flash, protrusions, or gate burrs shall not exceed 0.15 per end.
 - D. Body width does not include interlead flash. Interlead flash shall not exceed 0.50 per side.
 - E. Falls within JEDEC MO-187 variation AA, except interlead flash.

D (R-PDSO-G8)

PLASTIC SMALL OUTLINE

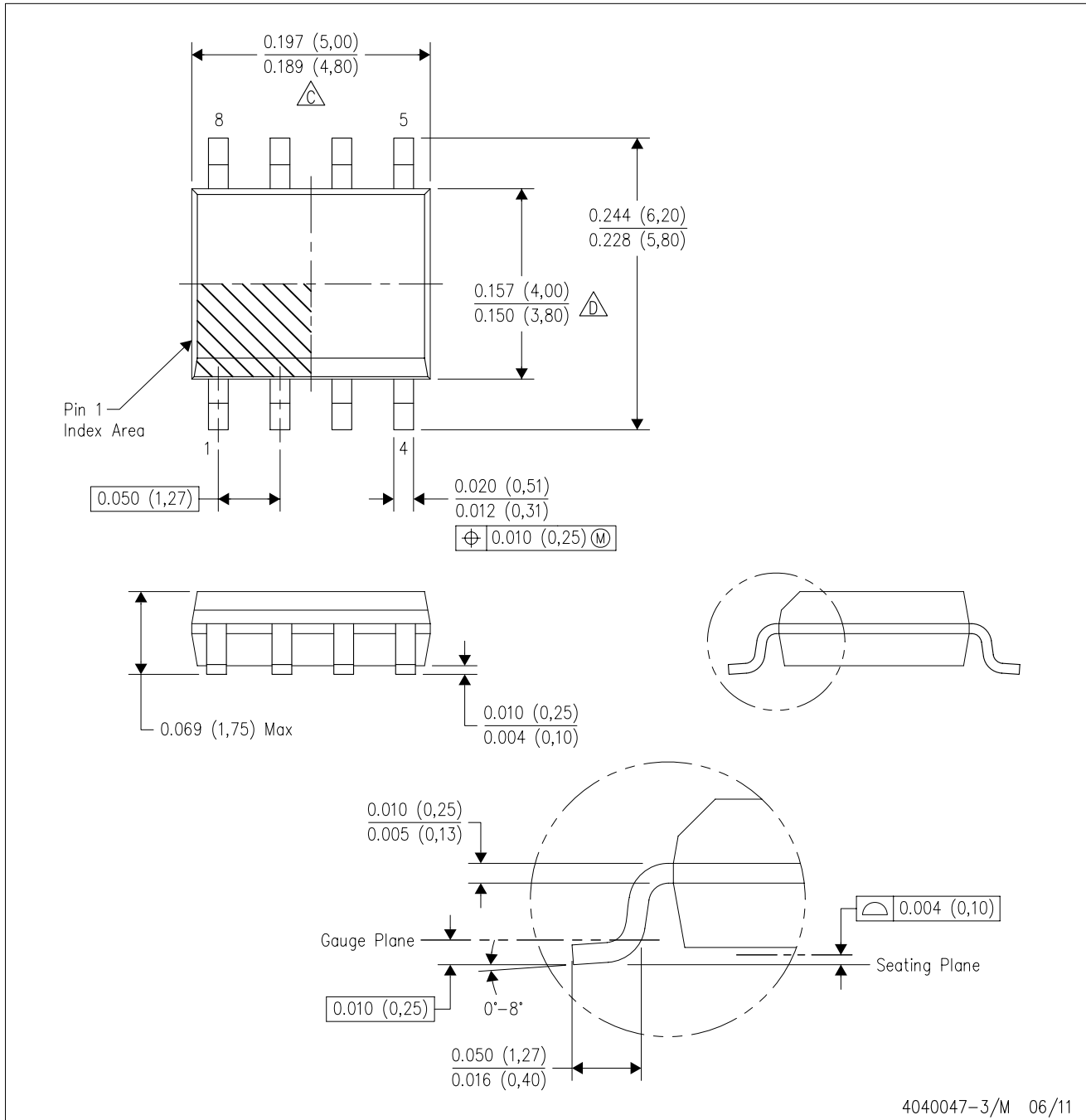

- NOTES:
- All linear dimensions are in inches (millimeters).
 - This drawing is subject to change without notice.
 - Body length does not include mold flash, protrusions, or gate burrs. Mold flash, protrusions, or gate burrs shall not exceed 0.006 (0,15) each side.
 - Body width does not include interlead flash. Interlead flash shall not exceed 0.017 (0,43) each side.
 - Reference JEDEC MS-012 variation AA.

IMPORTANT NOTICE

Texas Instruments Incorporated and its subsidiaries (TI) reserve the right to make corrections, enhancements, improvements and other changes to its semiconductor products and services per JESD46, latest issue, and to discontinue any product or service per JESD48, latest issue. Buyers should obtain the latest relevant information before placing orders and should verify that such information is current and complete. All semiconductor products (also referred to herein as "components") are sold subject to TI's terms and conditions of sale supplied at the time of order acknowledgment.

TI warrants performance of its components to the specifications applicable at the time of sale, in accordance with the warranty in TI's terms and conditions of sale of semiconductor products. Testing and other quality control techniques are used to the extent TI deems necessary to support this warranty. Except where mandated by applicable law, testing of all parameters of each component is not necessarily performed.

TI assumes no liability for applications assistance or the design of Buyers' products. Buyers are responsible for their products and applications using TI components. To minimize the risks associated with Buyers' products and applications, Buyers should provide adequate design and operating safeguards.

TI does not warrant or represent that any license, either express or implied, is granted under any patent right, copyright, mask work right, or other intellectual property right relating to any combination, machine, or process in which TI components or services are used. Information published by TI regarding third-party products or services does not constitute a license to use such products or services or a warranty or endorsement thereof. Use of such information may require a license from a third party under the patents or other intellectual property of the third party, or a license from TI under the patents or other intellectual property of TI.

Reproduction of significant portions of TI information in TI data books or data sheets is permissible only if reproduction is without alteration and is accompanied by all associated warranties, conditions, limitations, and notices. TI is not responsible or liable for such altered documentation. Information of third parties may be subject to additional restrictions.

Resale of TI components or services with statements different from or beyond the parameters stated by TI for that component or service voids all express and any implied warranties for the associated TI component or service and is an unfair and deceptive business practice. TI is not responsible or liable for any such statements.

Buyer acknowledges and agrees that it is solely responsible for compliance with all legal, regulatory and safety-related requirements concerning its products, and any use of TI components in its applications, notwithstanding any applications-related information or support that may be provided by TI. Buyer represents and agrees that it has all the necessary expertise to create and implement safeguards which anticipate dangerous consequences of failures, monitor failures and their consequences, lessen the likelihood of failures that might cause harm and take appropriate remedial actions. Buyer will fully indemnify TI and its representatives against any damages arising out of the use of any TI components in safety-critical applications.

In some cases, TI components may be promoted specifically to facilitate safety-related applications. With such components, TI's goal is to help enable customers to design and create their own end-product solutions that meet applicable functional safety standards and requirements. Nonetheless, such components are subject to these terms.

No TI components are authorized for use in FDA Class III (or similar life-critical medical equipment) unless authorized officers of the parties have executed a special agreement specifically governing such use.

Only those TI components which TI has specifically designated as military grade or "enhanced plastic" are designed and intended for use in military/aerospace applications or environments. Buyer acknowledges and agrees that any military or aerospace use of TI components which have **not** been so designated is solely at the Buyer's risk, and that Buyer is solely responsible for compliance with all legal and regulatory requirements in connection with such use.

TI has specifically designated certain components as meeting ISO/TS16949 requirements, mainly for automotive use. In any case of use of non-designated products, TI will not be responsible for any failure to meet ISO/TS16949.

Products

Audio	www.ti.com/audio
Amplifiers	amplifier.ti.com
Data Converters	dataconverter.ti.com
DLP® Products	www.dlp.com
DSP	dsp.ti.com
Clocks and Timers	www.ti.com/clocks
Interface	interface.ti.com
Logic	logic.ti.com
Power Mgmt	power.ti.com
Microcontrollers	microcontroller.ti.com
RFID	www.ti-rfid.com
OMAP Applications Processors	www.ti.com/omap
Wireless Connectivity	www.ti.com/wirelessconnectivity

Applications

Automotive and Transportation	www.ti.com/automotive
Communications and Telecom	www.ti.com/communications
Computers and Peripherals	www.ti.com/computers
Consumer Electronics	www.ti.com/consumer-apps
Energy and Lighting	www.ti.com/energy
Industrial	www.ti.com/industrial
Medical	www.ti.com/medical
Security	www.ti.com/security
Space, Avionics and Defense	www.ti.com/space-avionics-defense
Video and Imaging	www.ti.com/video

TI E2E Community

e2e.ti.com