

3 Gbps, HD, SD, DVB-ASI SDI Serializer and Cable Driver with LVDS Interface

General Description

The LMH0340/0040/0070/0050 SDI Serializers are part of National's family of FPGA-Attach SER/DES products supporting 5-bit LVDS interfaces with FPGAs. An FPGA Host will format data with supplied IP such that the output of the LMH0340 is compliant with the requirements of DVB-ASI, SMPTE 259M-C, SMPTE 292M and SMPTE 424M standards. See [Table 1](#) for details on which Standards are supported per device.

The interface between the SER (Serializer) and the FPGA consists of a 5 bit wide LVDS data bus, an LVDS clock and an SMBus interface. The LMH0340/0040/0070 SER devices include an integrated cable driver which is fully compliant with all of the SMPTE specifications listed above. The LMH0050 has a CML output driver that can drive a differential transmission line or interface to a cable driver.

The FPGA-Attach SER/DES family is supported by a suite of IP which allows the design engineer to quickly develop video applications using the SER/DES products. The SER is packaged in a physically small 48 pin LLP package.

Key Specifications

- Output compliant with SMPTE 424M, SMPTE 292M, SMPTE 259M-C and DVB-ASI (See Table 1)
- Typical power dissipation: 440 mW
- 30 ps typical output jitter (HD, 3G)

Features

- LVDS Interface to Host FPGA
- No external VCO or clock ref required
- Integrated Variable Output Cable Driver
- 3.3V SMBus configuration interface
- Integrated TXCLK PLL cleans clock noise
- Small 48pin LLP package
- Industrial Temperature range:-40°C to 85°C

Applications

- SDI interfaces for:
 - Video Cameras
 - DVRs
 - Video Switchers
 - Video Editing Systems

General Block Diagram

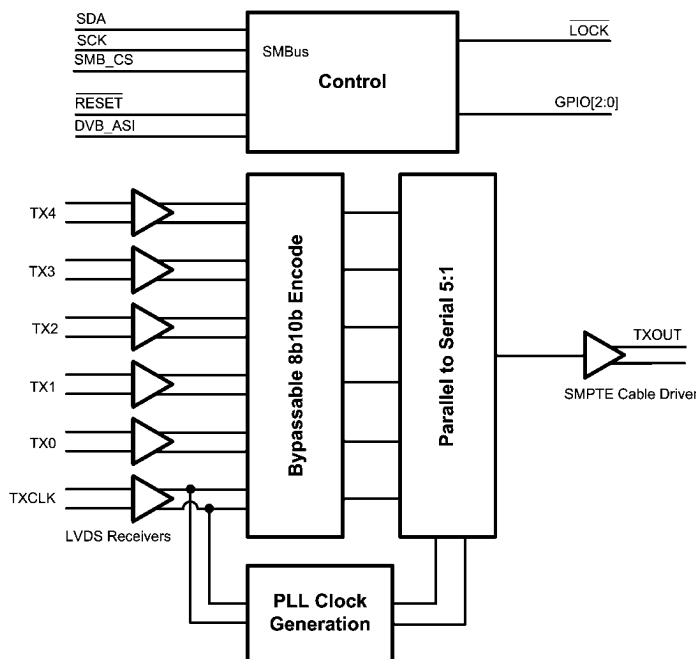

30017001

Pin Descriptions

Pin Name	Type	Description
LVDS Input Interface		
TX[4:0]+ TX[4:0]-	Input, LVDS	LVDS Data Input Pins Five channel wide DDR interface. Internal 100Ω termination.
TXCLK+ TXCLK-	Input, LVDS	LVDS Clock Input Pins DDR Interface. Internal 100Ω termination.
Serial Output Interface		
TXOUT+	Output, CML	Serial Digital Interface Output Pin Non-Inverting Output
TXOUT-	Output, CML	Serial Digital Interface Output Pin Inverting Output
SMBus Interface		
SDA	I/O, LVCMOS	SMBus Data I/O Pin
SCK	Input, LVCMOS	SMBus Clock Input Pin
SMB_CS	Input, LVCMOS	SMBus Chip Select Input Pin Device is selected when High.
Control and Configuration Pins		
RESET	Input, LVCMOS	Reset Input Pin H = normal mode L = device in RESET
LOCK	Output, LVCMOS	PLL LOCK Status Output H = unlock condition L = Device is Locked
DVB_ASI	Input, LVCMOS	DVB_ASI Select Input H = DVB_ASI Mode enabled L = Normal Mode enabled
GPIO[2:0]	I/O, LVCMOS	General Purpose Input / Output Software configurable I/O pins.
RSVD_H	Input, LVCMOS	Configuration Input – Must tie High Pull High via 5 kΩ resistor to V _{DD3V3}
Analog Inputs		
R _{SET}	Input, analog	Serial Output Amplitude Control Resistor connected from this pin to ground to set the signal amplitude. Nominally 8.06kΩ for 800mV output (SMPTE).
LF_CP	Input, analog	Loop Filter Connection
LF_REF	Input, analog	Loop Filter Reference
DNC		Do Not Connect – Leave Open
Power Supply and Ground		
V _{DD3V3}	Power	3.3V Power Supply connection
V _{DDPLL}	Power	3.3V PLL Power Supply connection
V _{DD2V5}	Power	2.5V Power Supply connection
GND	Ground	Ground connection – The DAP (large center pad) is the primary GND connection for the device and must be connected to Ground along with the GND pins.

TABLE 1. Feature Table

Device	SMPTE 424M Support (3G)	SMPTE 292M Support (HD)	SMPTE 259M Support (SD)	DVB-ASI Support	SMPTE compliant Cable Driver
LMH0340	X	X	X	X	X
LMH0040		X	X	X	X
LMH0070			X	X	X
LMH0050		X	X	X	

Absolute Maximum Ratings *(Note 1)*

If Military/Aerospace specified devices are required, please contact the National Semiconductor Sales Office/Distributors for availability and specifications.

Supply Voltage (V_{DD3V3})	-0.3V to +4.0V
Supply Voltage (V_{DD2V5})	-0.3V to +3.0V
LVC MOS input voltage	-0.3V to ($V_{DD3V3}+0.3V$)
LVC MOS output voltage	-0.3V to ($V_{DD3V3}+0.3V$)

SMBus I/O voltage	-0.3V to +3.6V
LVDS Input Voltage	-0.3V to +3.6V
Junction Temperature	+150°C
Storage Temperature	-65° to 150°C
Thermal Resistance—	25°C/W
Junction to Ambient— θ_{JA}	
ESD Rating—Human Body Model,	$\geq \pm 8kV$
1.5 K Ω , 100 pF	

Recommended Operating Conditions

Parameter	Min	Typ	Max	Units
Supply Voltage (V_{DD3V3} -GND)	3.135	3.3	3.465	V
Supply Voltage (V_{DD2V5} -GND)	2.375	2.5	2.625	V
Supply noise amplitude (10 Hz to 50 MHz)			100	mV _{p-p}
Ambient Temperature	-40	+25	+85	°C
Case Temperature			100	°C
TXCLK input frequency – LMH0340	27		297	MHz
TXCLK input frequency – LMH0040	27		149	MHz
TXCLK input frequency – LMH0070	26.5	27	28	MHz
TXCLK input frequency – LMH0050	27		149	MHz
LVDS PCB board trace length (mismatch <2%)			25	cm
Output Driver Pullup Resistor Termination Voltage <i>(Note 10)</i>		2.5	2.625	V

Electrical Characteristics

Over supply and Operating Temperature ranges unless otherwise specified. *(Note 2)*

Symbol	Parameter	Condition	Min	Typ	Max	Units
$I_{DD2.5}$	2.5V supply current for LMH0340, LMH0040, or LMH0070	2.97 Gbps		93	102	mA
		1.485 Gbps		80	87	mA
		270 Mbps		63	69	mA
	2.5V supply current for LMH0050	1.485 Gbps		87	95	mA
		270 Mbps		70	75	mA
$I_{DD3.3}$	3.3V supply current for LMH0340, LMH0040, or LMH0070	2.97 Gbps		73	85	mA
		1.485 Gbps		73	85	mA
		270 Mbps		73	85	mA
	3.3V supply current for LMH0050	1.485 Gbps		73	85	mA
		270 Mbps		73	85	mA
PD	Power Consumption	LMH0340 - 2.97 Gbps		475	545	mW
		LMH0040 - 1.485 Gbps		440	510	mW
		LMH0050 - 1.485 Gbps		460	525	mW
		LMH0050 - 270 Mbps		415	485	mW
		LMH0070 - 270 Mbps		400	470	mW

Control Pin Electrical Characteristics

Over supply and Operating Temperature ranges unless otherwise specified. Applies to DVB_ASI, $\overline{\text{RESET}}$, GPIO[2:0] and $\overline{\text{LOCK}}$. *(Note 2)*

Symbol	Parameter	Condition	Min	Typ	Max	Units
V_{IH}	High Level Input Voltage		2.0		V_{DD3V3}	V
V_{IL}	Low Level Input Voltage		0		0.8	V
V_{OH}	High Level Output Voltage	$I_{OH} = -2$ mA	2.7	3.3		V
V_{OL}	Low Level Output Voltage	$I_{OL} = 2$ mA			0.3	V
V_{CL}	Input Clamp Voltage	$I_{CL} = -18$ mA		-0.79	-1.5	V

Symbol	Parameter	Condition	Min	Typ	Max	Units
I_{IN}	Input Current	$V_{IN}=0.4V, 2.5V$ or V_{DD}	-35		35	μA
I_{OS}	Output Short Circuit Current	$V_{OUT}=0V$		-40		mA

LVDS Input Electrical Characteristics

Over supply and Operating Temperature ranges unless otherwise specified. (Note 2)

Symbol	Parameter	Condition	Min	Typ	Max	Units
V_{TH}	Differential Input High threshold	$0.05V < V_{CM} < 2.4V$			+100	mV
V_{TL}	Differential Input Low threshold		-100			mV
R_{LVIN}	Input Impedance	Measured between LVDS pairs	85	100	115	Ω

LVDS Switching Characteristics

Over supply and Operating Temperature ranges unless otherwise specified. (Note 2)

Symbol	Parameter	Condition	Min	Typ	Max	Units
t_{CIP}	TxCLKIN Period	See Figure 1	3.2	2T	37	ns
t_{CIT}	TxCLKIN Transition Time	See Figure 2	0.5	1.0	3.0	ns
t_{CIH}	TxCLKIN IN High Time	See Figure 1	0.7T	T	1.3T	ns
t_{CIL}	TxCLKIN IN Low Time	See Figure 1	0.7T	T	1.3T	ns
t_{XIT}	TxIN Transition Time		0.15		3	ns
t_{STC}	TxIN Setup to TxCLKIN	See Figure 1, (Note 11)	-550			ps
t_{HTC}	TxIN Hold to TxCLKIN		900			ps

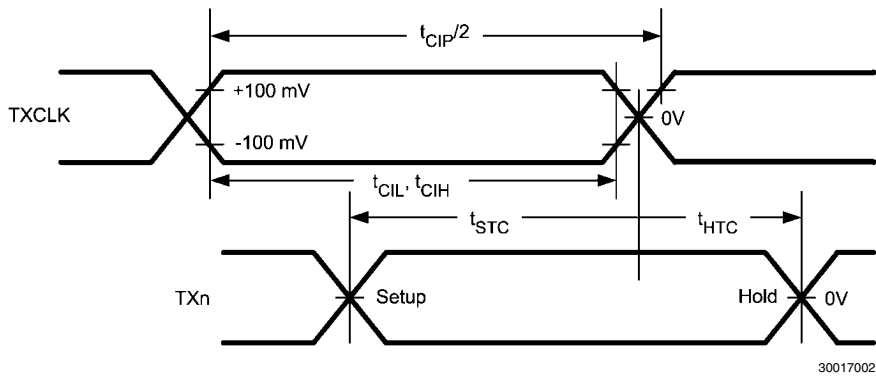

FIGURE 1. LVDS Input Timing Diagram



FIGURE 2. Transmit Clock Transition Times

SMBus Input Electrical Characteristics

Over supply and Operating Temperature ranges unless otherwise specified. (Note 2)

Symbol	Parameter	Condition	Min	Typ	Max	Units
V _{SIL}	Data, Clock Input Low Voltage				0.8	V
V _{SIH}	Data, Clock Input High Voltage		2		V _{SDD}	V
I _{SPULLUP}	Current through pull-up resistor or current source	(Note 3)	4			mA
V _{SDD}	Nominal Bus Voltage		2.375		3.6	V
I _{SLEAKB}	Input Leakage per bus segment	(Note 3)	-200		200	μA
I _{SLEAKP}	Input Leakage per pin		-10		10	μA
C _{SI}	Capacitance for SMBdata and SMBclk	(Note 3, Note 4)			10	pF
R _{STERM}	Termination Resistance	V _{SDD3V3} (Note 5, Note 4, Note 3)		1000		Ω

SMBus Switching Characteristics

Over supply and Operating Temperature ranges unless otherwise specified. (Note 2)

Symbol	Parameter	Condition	Min	Typ	Max	Units
f _{SMB}	Bus Operating Frequency		10		100	kHz
t _{BUF}	Bus free time between stop and start condition		4.7			μs
t _{HD:STA}	Hold time after (repeated) start condition. After this period, the first clock is generated	At I _{SPULLUP} = MAX	4.0			μs
t _{SU:STA}	Repeated Start condition setup time		4.7			μs
t _{SU:STO}	Stop Condition setup time		4.0			μs
t _{HD:DAT}	Data hold time		300			ns
t _{SU:DAT}	Data setup time		250			ns
t _{LOW}	Clock Low Time		4.7			μs
t _{HIGH}	Clock High Time		4.0		50	μs
t _F	Clock/data fall time	20% to 80%			300	ns
t _R	Clock/data rise time				1000	ns
t _{SU:CS}	SMB_CS setup time			30		ns
t _{POR}	Time in which a device must be operational after power on				500	ms

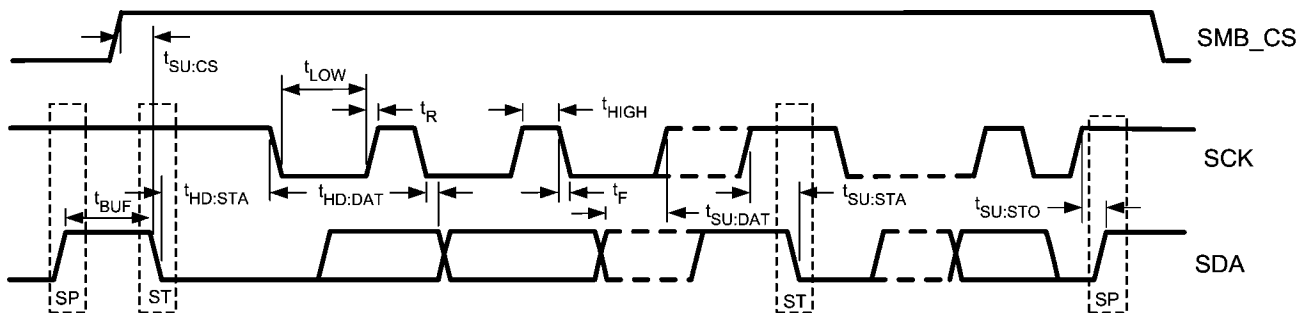

30017004

(levels are V_{SIL} and V_{SIH})

FIGURE 3. SMBus Timing Parameters

SDI Output Characteristics — LMH0340 / LMH0040 / LMH0070

Over supply and Operating Temperature ranges unless otherwise specified. (Note 2)

Symbol	Parameter	Condition	Min	Typ	Max	Units
V_{OD}	SDI Output Voltage	into 75 Ω load	720	800	880	mV
DR	SDI Output Datarate	LMH0340	270		2,970	Mbps
		LMH0040	270		1,485	Mbps
		LMH0070		270		Mbps
t_r	SDI Output Rise Time	2.97 Gbps		90	135	ps
		1.485 Gbps		90	220	ps
		<1.485 Gbps	400	700	1000	ps
t_f	SDI Output Fall Time	2.97 Gbps		90	135	ps
		1.485 Gbps		90	220	ps
		<1.485 Gbps	400	700	1000	ps
Δt_t	Mismatch between rise and fall time	≥ 1.485 Gbps (Note 9)			30	ps
t_{SD}	Propagation Delay Latency	See Figure 4		9.5		TXCLK cycle
t_j	Peak to Peak Alignment Jitter	≥ 1.485 Gbps (Note 6)		30	50	ps
		270 Mbps (Note 6)		100	200	ps
RL	Output Return Loss — EVK Specification (Note 12)	Measured 5 MHz to 1485 MHz	15	20		dB
		Measured 1485 MHz to 2970 MHz	10	15		dB
t_{OS}	Output Overshoot (Note 9)	2.97 Gbps			8	%
		1.485 Gbps			5	%
		270 Mbps			2	%

CML Output Characteristics — LMH0050

Over supply and Operating Temperature ranges unless otherwise specified. (Note 2)

Symbol	Parameter	Condition	Min	Typ	Max	Units
V_{OD}	Output Voltage	into 100 Ω differential load	1175		1450	mV
DR	Data Rate		270		1485	Mbps
t_r	Output Rise Time				100	ps
t_f	Output Fall Time				100	ps
t_j	Peak-to-Peak Alignment Jitter	1.485 Gbps		25	50	ps
R_{OUT}	Output Termination Resistance	Output Pin to V_{DD2V5} Pin	40	50	60	Ω

Device Switching Characteristics

Over supply and Operating Temperature ranges unless otherwise specified. (*Note 2*)

Symbol	Parameter	Condition	Min	Typ	Max	Units
t_{TPLD}	Device Lock Time	2.97 Gbps			10	ms
		1.485 Gbps			11	ms
		270 Mbps			15	ms

Note 1: “Absolute Maximum Ratings” are limits beyond which the safety of the device cannot be guaranteed. It is not implied that the device will operate up to these limits.

Note 2: Typical Parameters measured at $V_{DD3V3}=3.3V$, $V_{DD2V5}=2.5V$, $T_A=25^{\circ}C$. They are for reference purposes and are not production tested.

Note 3: Recommended value—Parameter is not tested.

Note 4: Recommended maximum capacitance load per bus segment is 400 pF.

Note 5: Maximum termination voltage should be identical to the device supply voltage.

Note 6: Measured in accordance with SMPTE RP184. 100% production tested.

Note 7: Register 0x30'h bits [7:5] is at default value of 011'b

Note 8: Measured with $R_{SET} = 8.06\ k\Omega$ and register 0x69'h at default value.

Note 9: Specification guaranteed by characterization.

Note 10: Applies to LMH0340, LMH0040, and LMH0070.

Note 11: Parameter uses default settings in registers: 0x24'h and 0x30'h.

Note 12: Output Return Loss specification applies to measurement on the EVK PCB (LMH0340 ALP Daughter Card) per SMPTE requirements.

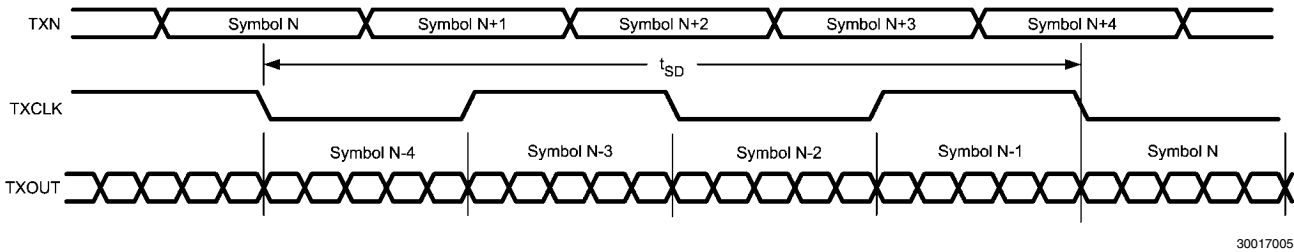

FIGURE 4. LVDS Interface Propagation Delay

Functional Description

DEVICE OPERATION

The SER is used in digital video signal origination equipment. It is intended to be operated in conjunction with an FPGA host which preprocesses data for it, and then provides this data over the five bit wide data path. Provided the host has properly formatted the data for the SER, the output of the device will be compliant with DVB-ASI, SMPTE 259M-C, SMPTE 292M or SMPTE 424M depending upon the output mode selected.

National Semiconductor offers IP in source code format to perform the appropriate formatting of the data, as well as evaluation platforms to assist in the development of target applications. For more information please contact your local National Semiconductor Sales Office/Distributor.

POWER SUPPLIES

The SER has several power supply pins, at 2.5V as well as 3.3V. It is important that these pins all be connected, and properly bypassed. Bypassing should consist of parallel 4.7 μ F and 0.1 μ F capacitors as a minimum, with a 0.1 μ F capacitor on each power pin. The device has a large contact in the center of the bottom of the package. This contact must be connected to the system GND as it is the major ground connection for the device. A 22 μ F capacitor is required on the V_{DDPLL} pin which is connected to the 3.3V rail.

Discrete bypassing is ineffective above 30 MHz to 50 MHz in power plane-based distribution systems. Above this frequency range, the intrinsic capacitance of the power-ground system can be used to provide additional RF bypassing. To make the best use of this, make certain that there are PCB layers dedicated to the Power supplies and to GND, and that they are placed next to each other to provide a distributed capacitance between power and GND.

The SER will work best when powered from linear regulators. The output of linear regulators is generally cleaner with less noise than switching regulators. Output filtering and power system frequency compensation are generally simpler and more effective with linear regulators. Low dropout linear regulators are available which can usually operate from lower input voltages such as logic power supplies, thereby reducing regulator power dissipation. Cascading of low dropout regulators should not be done since this places the entire supply current load of both load systems on the first regulator in the cascade and increases its loading and thermal output.

POWER UP

The 3.3V power supply should be brought up before the 2.5V supply. The timing of the supply sequencing is not important. The device has a power on reset sequence which takes place once both power supplies are brought up. This sequence will reset all register contents to their default values, and will place the PLLs into link acquisition mode, attempting to lock on the TXCLK input.

RESET

There are three ways in which the device may be reset. There is an automatic reset which happens on power-up; there is a reset pin, which when brought low will reset the device, with normal operation resuming when the pin is driven high again. The third way to reset the device is a soft reset, implemented via a write to the reset register. This reset will put all of the register values back to their default values, except it will not affect the address register value if the SMBus default address has been changed.

LVDS INPUTS

The SER has LVDS inputs that conform with the ANSI/TIA/EIA-644–A Standard. These inputs have an internal 100 Ω resistor across the inputs which allows for the closing of a current loop interface from the LVDS driver in the host. It is recommended that the PCB trace between the FPGA and the transmitter be less than 25cm. Longer PCB traces may introduce signal degradation as well as channel skew which could cause serialization errors. This connection between the host and the SER should be over a controlled impedance transmission line with an impedance which matches the termination resistor – usually 100 Ω . Setup and hold times are specified in the LVDS Switching Characteristics table, however there is the ability to change these by use of the CLK delay adjustment available via the SMBus, and writing to register 0x30'h.

LVDS DATA ORDER

When serializing the data, the data bit latched in on TX0 is output first, followed by TX1, TX2, TX3 and then TX4. If starting with a 10 bit word, T0..T9, with T0 being the LSB, and it is desired that this be serialized such that the LSB is sent out first, then the least significant 5 bit word would be provided to the serializer first, followed by the most significant word, and the resulting serialized output would have the LSB being sent first, and the 10 bit MSB (T9) would be transmitted last. If it is desired to reverse the serialization order, such that the bit presented on TX4 is output first, this mode of operation may be selected via register 0x2E'h.

LOOP FILTER

The SER has an internal PLL which is used to generate the serialization clock from the parallel clock input. The loop filter for this PLL is external, and for optimum results in Serial Digital Interface applications, a capacitor and a resistor in series should be connected between pins 26 and 27. Recommended value for the capacitor is 0.1 μ F. Recommended value for the resistor is 500 Ω .

PLL FILTER / BYPASS

The SER has an external filter capacitor for the PLL. The recommended value for this capacitor is 22 μ F with a connection to the 3.3V rail.

DVB_ASI MODE

The SER has a special mode for DVB-ASI. In this mode, the input signal on TX4 \pm is treated as a data valid bit, if high, then the four bit nibbles from TX0-TX3 are taken to form an 8 bit word, which is then converted to a 10 bit code via an internal 8b10b encoder and this 10 bit word is serialized and driven on the output. The nibble taken in on the rising edge of the clock is the most significant nibble and the nibble taken in on the falling edge is the least significant nibble. If TX4 \pm is low, then the input on TX0-TX3 are ignored and the 10b idle character is inserted in the output stream. The Idle character can be reprogrammed to be any 10 bit code desired via registers 0x11'h and 0x12'h.

SDI OUTPUT INTERFACING

The serial outputs provide low-skew complimentary or differential signals. The output buffer is a current mode design, with a high impedance output. To drive a 75 Ω transmission line connect a 75 Ω resistor from each of the output pins to 2.5V. This resistor has two functions – it converts the current output to a voltage, which is used to drive the cable, and it acts as the back termination resistor for the transmission line. The resistor should be placed as close to the output pin as is

practicable. The output driver automatically adjusts its slew rate depending on the input data rate so that it will be in compliance with SMPTE 259M, SMPTE292M or SMPTE 424M as appropriate. In addition to output amplitude and rise/fall time specifications, the SMPTE specs require that SDI outputs meet an Output Return Loss (ORL) specification. There are parasitic capacitances that will be present both at the output pin of the device and on the application printed circuit board. To optimize the return loss implement a series network comprised of a parallel inductor and resistor. The actual values for these components will vary from application to application, but the typical interface circuit shows values that would be a good starting point. *Figure 5* shows an equivalent output circuit for the LMH0340 / LMH0040 / LMH0070. The collectors present a high impedance current source. The external 75Ω resistors will provide the back termination resistance as well as converting the current to a voltage – with the addition of the termination resistance at the load, there will be an overall output resistance of 37.5Ω, which in conjunction with the 24-mA current source will develop the 800mV swings called for in the standard.

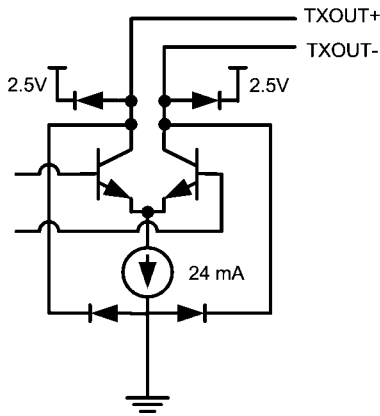

30017007

FIGURE 5. Simplified SDI Output Circuit

Care must be taken in the layout of the output circuitry to meet SMPTE return loss specifications as any parasitic impedances or transmission line discontinuities will result in reflections which will adversely affect the output return loss. For more details on how to get good output return loss, please refer to the application note “Successful design with the FPGA-Attach SER/DES”.

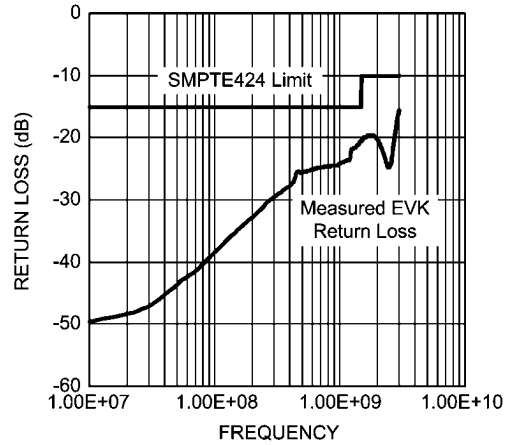

30017011

FIGURE 6. SDI Output Return Loss (EVK Example)

The amplitude of the output is guaranteed to be compliant with SMPTE specifications if the specified value of R_{SET} resistor is used, however if the designer wishes to change the output amplitude, there are two methods by which this can be done. By changing the value of resistor connected to the R_{SET} pin, the output amplitude will be adjusted.

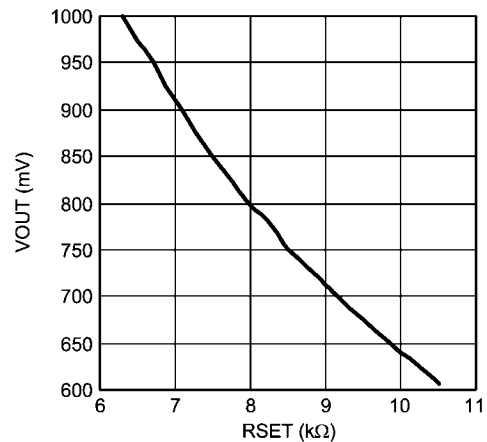

30017012

FIGURE 7. Output Voltage vs. R_{SET}

CML Output Interfacing

The LMH0050 does not include the internal SMPTE cable driver, as its outputs are CML, include internal 50 Ω pull up resistors, and are intended to drive 100 Ω transmission lines. The LMH0050 outputs may either be connected to a differential transmission medium such as twisted pair cable, or used to drive an external cable driver.

Power Down Mode

If the device is not to be used, some power can be saved by writing a '0x40h' to register 0x26'h, and a 0x10'h to register 0x01'h. The write to register 0x26'h will disable the input buffers of the device, and the write to register 0x01'h will power down the output buffer. In this mode, the device power dissipation can be expected to be reduced by approximately 30%. There are portions of the circuit which will automatically power down if there is no clock present on the TXCLK input, so this method can be used to further reduce the power.

SMBus INTERFACE

The configuration bus conforms to the System Management Bus (SMBus) 2.0 specification. SMBus 2.0 includes multiple options. The optional ARP (Address Resolution Protocol) feature is not supported. The I/O rail is 3.3V only and is not 5V tolerant. The use of the SMB_CS signal is recommended for applications with multi-drop applications (multiple devices to a host).

The SMBus is a two wire interface designed for the communication between various system component chips, additional signals maybe required for chip select function depending upon application. By accessing the control functions of the circuit via the SMBus, signal count is kept to a minimum while allowing a maximum amount of versatility. The SMBus has three pins to control it: an SMBus CS pin which enables the SMBus interface for the device, a Clock and a Data line. In applications where there might be several SER devices, the SDA and SCK pins can be bussed together and the individual devices to be communicated with may be selected via their respective SMB_CS pin. The SCK and SDA are both open drain and are pulled high by external pullup resistors. The SER has several internal configuration registers which may be accessed via the SMBus. These registers are listed in [SER Register Detail Table](#).

TRANSFER OF DATA TO THE DEVICE VIA THE SMBus

During normal operation the data on SDA must be stable during the time when SCK is high.

START / STOP / IDLE CONDITIONS

There are three unique states for the SMBus:

- START** A HIGH-to-LOW transition on SDA while SCK is High indicates a message START condition
- STOP** A LOW-to-HIGH transition on SDA while SCK is High indicates a message STOP condition.
- IDLE** If SCK and SDA are both High for a time exceeding t_{BUF} from the last detected STOP condition or if they are high for a total exceeding the maximum specification for t_{HIGH} then the bus will transfer to the IDLE state.

SMBus TRANSACTIONS

A transaction begins with the host placing the SER SMBus into the START condition. Then a byte (8 bits) is transferred, MSB first, followed by a ninth ACK bit. ACK bits are '0' to signify an ACK, or '1' to signify NACK. After this the host holds the SCK line Low, and waits for the receiver to raise the SDA line as an ACKnowledge that the byte has been received.

REGISTER WRITE

To write a data value to a register in the SER, the host writes three bytes to the SER. The first byte is the device address—the device address is a 7 bit value, and if writing to the SER the last bit (LSB) is set to '0' to signify that the operation is a write. The second byte written is the register address, and the third byte written is the data to be written into the addressed register. If additional data writes are performed, the register address is automatically incremented. At the end of the write cycle the host places the bus in the STOP state.

REGISTER READ

To read the data value from a register, first the host writes the device address with the LSB set to a '0' denoting a write, and then the register address is written to the device. The host then reasserts the START condition, and writes the device address once again, but this time with the LSB set to a '1' denoting a read, and following this the SER will drive the SDA line with the data from the addressed register. The host indicates that it has finished reading the data by asserting a '0' for the ACK bit. After reading the last byte, the host will assert a '1' for NACK to indicate to the SER that it does not require any more data.

Note that the SMBus pins are not 5V compliant and they must be driven by a 3.3V source.

SMBus CONFIGURATIONS

Many different configurations of the SMBus are possible and depend upon the specific requirements of the applications. Several possible applications are described.

CONFIGURATION 1

The SER SMB_CS may be tied High (always enabled) since it is the only device on the SMBus. See [Figure 8](#).

CONFIGURATION 2

Since the multiple SER devices have the same address, the use of the individual SMB_CS signals is required. To communicate with a specific device, its SMB_CS is driven High to select the device. After the transaction is complete, its SMB_CS is driven Low to disable its SMB interface. Other devices on the bus may now be selected with their respective chip select signals and communicated with. See [Figure 9](#).

CONFIGURATION 3

The addressing field is limited to 7-bits by the SMBus protocol. Thus it is possible that multiple devices may share the same 7-bit address. An optional feature in the SMBus 2.0 specification supports an Address Resolution Protocol (ARP). This optional feature is not supported by the LMH0340/0040/0070/0050 devices. Solutions for this include: the use of the independent SMB_CS signals, independent SMBus segments, or other means. See [Figure 10](#).

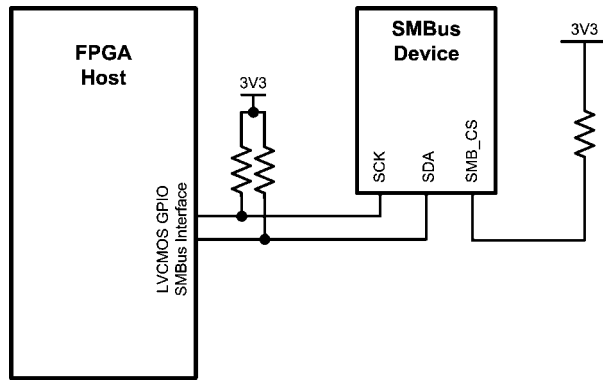

30017015

FIGURE 8. SMBus Configuration 1 — Host to single device

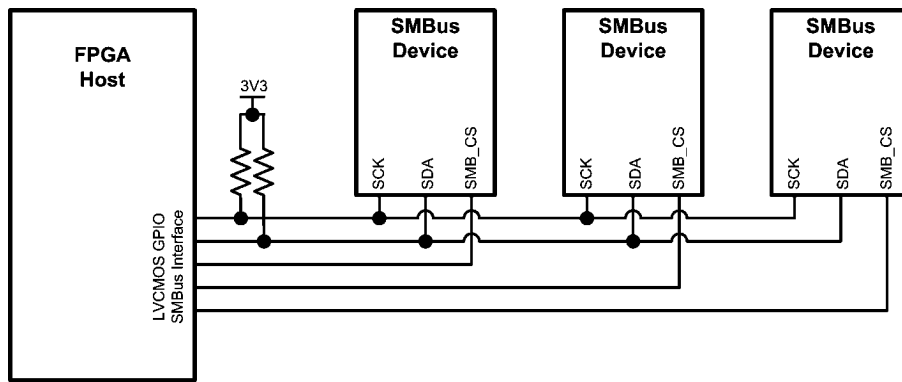

30017016

FIGURE 9. SMBus Configuration 2 — Host to multiple devices with SMB_CS signals

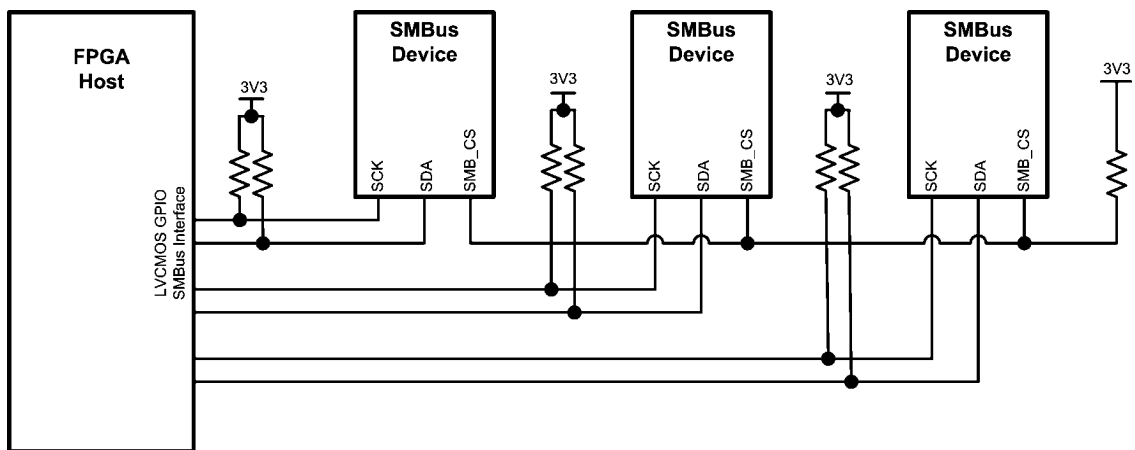

30017017

FIGURE 10. SMBus Configuration 3 — Host to multiple devices with multiple SMBus Interfaces

GENERAL PURPOSE I/O PINS GPIO[2:0]

The SER has three pins which can be configured to provide direct access to certain register values via a dedicated pin. For example if a particular application required fast action to the condition of the serializer losing its input clock, the TXCLK detect status bit could be routed directly to an external pin where it might generate an interrupt for the host processor. GPIO pins can be configured to be in TRI-STATE®(High Impedance) mode, the buffers can be disabled, and when used as inputs can be configured with a pullup resistor, a pulldown resistor or no input pin biasing at all. When the GPIO pins are being used as inputs, there is the ability to have an internal pullup or pull down resistor. This is selected via the GPIO Configuration registers.

Each of the GPIO pins has a register to control it. For each of these registers, the upper 4 bits are used to define what function is desired of the GPIO pin with options being slightly different for each of the three GPIO pins. The pins can be used to monitor the status of various internal states of the SER device, to serve as an input from some external stimulus, and for output to control some external function.

GPIO_0 FUNCTIONS

- Allow for the output of a signal programmed by the SMBus
- Allow the monitoring of an external signal via the SMBus
- Monitor Status of TXCLK signal
- Monitor Status of TXCLKDetect
- Monitor Power On Reset

GPIO_1 FUNCTIONS

- Monitor Power On Reset
- Allow for the output of a signal programmed by the SMBus
- Allow the monitoring of an external signal via the SMBus
- Monitor LOS for data bit 0
- Monitor LOS for data bit 1
- Monitor LOS for data bit 2
- Monitor LOS for data bit 3
- Monitor LOS for data bit 4

GPIO_2 FUNCTIONS

- Allow for the output of a signal programmed by the SMBus
- Allow the monitoring of an external signal via the SMBus
- Serializer Clock output

Bits 2 and 3 are used to determine the status of the internal pullup/pulldown resistors on the device—they are loaded according to the following truth table:

- 00: pullup and pulldown disabled
- 01: pulldown enabled
- 10: pullup enabled
- 11: Reserved

Bit 1 is used to enable or disable the input buffer. If the GPIO pin is to be used as an output pin, then this bit must be set to a '0' disabling the output.

The LSB is used to switch the output between normal output state and high impedance mode. If the GPIO is to be used as an input pin, this bit must be set to '0' placing the output in high Z mode.

As an example, if you wanted to use the GPIO₀ pin to reflect the status of the $\overline{\text{LOCK}}$ pin, you would load the appropriate register with the value 0001 0001b.

POTENTIAL APPLICATION FOR GPIO PINS

In addition to being useful debug tools while bringing a design up, there are other practical uses to which the GPIO pins can be put:

Sensing if a cable is connected to an output –

When connecting the BNC cable to the output, connect the shield of the connector to GND via a capacitor—making it an AC GND, but a DC open. Now connect that shield to one of the GPIO connections which you configure as an input with a pullup. With no cable on the BNC, the GPIO pin will see a high state, but once a terminated cable is connected, the shield will be brought down and you will read a low state.

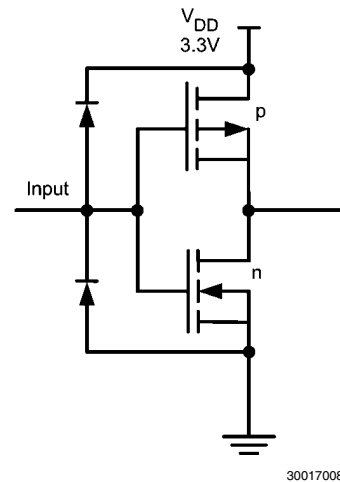

FIGURE 11. Simplified LVCMOS Input Circuit

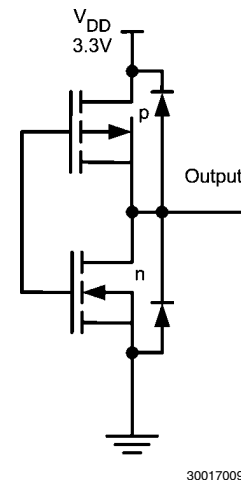

FIGURE 12. Simplified LVCMOS Output Circuit

Application Information

PCB RECOMMENDATIONS

The SMPTE Serial specifications have very stringent requirements for output return loss on drivers. The output return loss will be degraded by non-idealities in the connection between the SER (all variants with the exception of the LMH0050) and the output connector. All efforts should be taken to minimize the trace lengths for this area, and to assure that the characteristic impedance of this trace is 75Ω .

It is recommended that the PCB traces between the host FPGA and the SER be no longer than 10 inches (25cm) and that the traces be routed as differential pairs, with very tight matching of line lengths and coupling within a pair, as well as equal length traces for each of the six pairs. For additional information on layout and soldering of the LLP package, please refer to the applications note 'AN 1187'

PCB Design do's and don'ts:

- DO Whenever possible dedicate an entire layer to each power supply – this will reduce the inductance in the supply plane.
- DO use surface mount components whenever possible
- DO place bypass capacitors close to each power pin
- DON'T create ground loops – pay attention to the cutouts that are made in your power and ground planes to make sure that there are not opportunities for loops.
- DON'T allow discontinuities in the ground planes – return currents will follow the path of least resistance – for high frequency signals this will be the path of least inductance.
- DO place the SER outputs as close as possible to the edge of the PCB where it will connect to the outside world.
- DO make sure to match the trace lengths of all differential traces, both between the sides of an individual pair, and from pair to pair.
- DO remember that VIAs have significant inductance – when using a via to connect to a power supply or ground layer, two in parallel are better than one.
- DO connect the slug on the bottom of the package to a solid Ground connection. This contact is used for the major GND connection to the device as well as serving as a thermal via to keep the die at a low operating temperature.
- There is an application note available which discusses layout suggestions for the SER in greater detail.

TYPICAL SMPTE APPLICATIONS CIRCUIT

A typical application circuit for the LMH0340 is shown in [Figure 13](#). Alternately this could also employ the LMH0040 or LMH0070 Serializers in lower data rate SMPTE applications. The TX interface between the host FPGA and the SER is composed of a 5-bit LVDS Data bus and its LVDS clock. This

is a point-to-point interface and the SER includes on-chip 100 terminations. Pairs should be of equal length to minimize any skew impact. The LVDS clock (TXCLK) uses both edges to transfer the data.

An SMBus is also connected from the host FPGA to the SER. If the SMBus is shared, a chip select signal is used to select the device being addressed. The SCK and SDA signals require a pull up resistor. The SMB_CS is driven by a GPO signal from the FPGA. Depending on the FPGA I/O it may also require a pull up unless it is a push / pull output.

Depending upon the application, several other GPIO signals maybe used. This includes the DVB_ASI and RESET input signals. If these pins are not used, then must be tied off to the desired state. The LOCK signal maybe used to monitor the SER. If it is unused, leave the pin as a NC (or route to a test point).

The SER includes a SMPTE compliant cable driver. While this is a differential driver, it is commonly used single-endedly to drive 75Ω coax cables. External 75Ω pull up resistors are used to the 2.5V rail. The active output(s) also includes a matching network to meet the required Output Return Loss SMPTE specification. While application specific, in general a series 75Ω resistor shunted by a 6.8 nH inductor will provide a starting value to design with. The signal is then AC coupled to the cable with a 4.7 μ F capacitor. If the complementary output is not used, simply terminate it after its AC coupling capacitor to ground. This output (even though its inverting) may still be used for a loop back or 1:2 function due to the nature of the NRZI coding that the SMPTE standards require. The output voltage amplitude of the cable driver is set by the R_{SET} resistor. For single-ended applications, an 8.06 k Ω resistor is connected between this pin and ground to set the swing to 800mV.

The PLL loop filter is external for the SER. A capacitor is connected in series to a resistor between the LF_CP and LF_REF pins. Typical values are 500 Ω and 0.1 μ F.

There are several configuration pins that requiring setting to the proper level. The RSVD_H pins should be pulled High to the 3.3V rail with a 5 k Ω resistor. Depending upon the application the DVB_ASI pin may be tied off or driven.

There are three supply connections (see By Pass discussion and also Pin Descriptions for recommendations). The two main supplies are the 3.3V rail and the 2.5V rail. There is also a 3.3V connection for the PLL circuitry.

There are multiple Ground connections for the device. The main ground connection for the SER is through the large center DAP pad. This **must** be connected to ground for proper device operation. In addition, multiple other inputs are required to be connected to ground as show in the figure and listed in the Pin Description table.

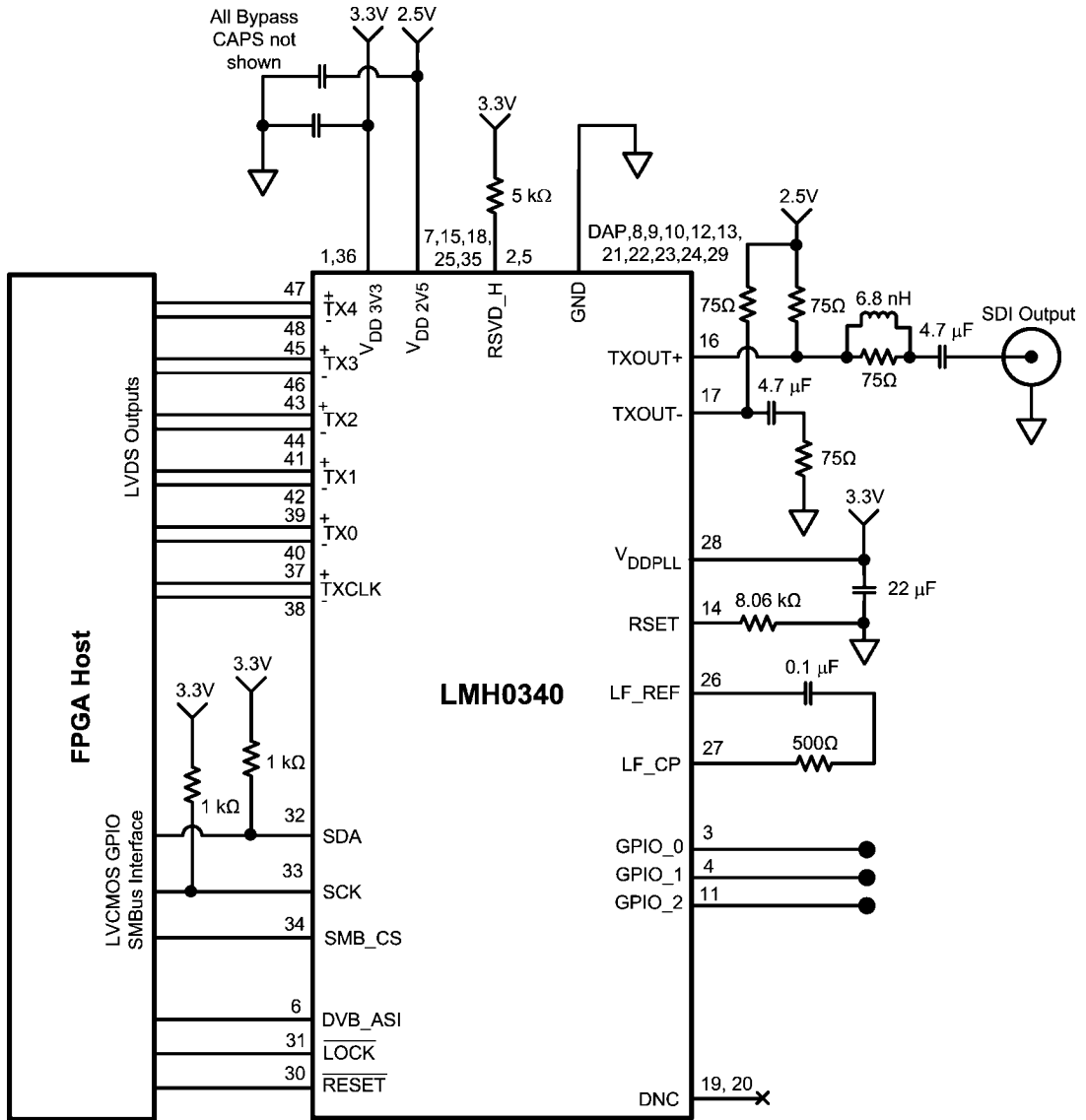

30017006

FIGURE 13. Typical SMPT Application Circuit

TYPICAL LMH0050 CML APPLICATIONS CIRCUIT

A typical application circuit for the LMH0050 is shown in [Figure 14](#).

The TX interface between the host FPGA and the SER is composed of a 5-bit LVDS Data bus and its LVDS clock. This is a point-to-point interface and the SER includes on-chip 100 terminations. Pairs should be of equal length to minimize any skew impact. The LVDS clock (TXCLK) uses both edges to transfer the data.

An SMBus is also connected from the host FPGA to the SER. If the SMBus is shared, a chip select signal is used to select the device being addressed. The SCLK and SDA signals require a pull up resistor. The SMB_CS is driven by a GPO signal from the FPGA. Depending on the FPGA I/O it may also require a pull up unless it is a push / pull output.

Depending upon the application, several other GPIO signals maybe used. This includes the DVB_ASI and RESET input signals. If these pins are not used, then must be tied off to the desired state. The LOCK signal maybe used to monitor the SER. If it is unused, leave the pin as a NC (or route to a test point).

The LMH0050 SER includes a CML cable driver. This is a differential driver, and includes internal 50 Ω pull up resistors

to the 2.5V rail. The output voltage amplitude of the cable driver is set by the R_{SET} resistor. The R_{SET} resistor recommended value for the LMH0050 is 9.1K Ω . It is intended to drive 100 Ω differential pairs or twisted pair cables.

The PLL loop filter is external for the SER. A capacitor is connected in series to a resistor between the LF_CP and LF_REF pins. Typical values are 500 Ω and 0.1 μ F.

There are several configuration pins that requiring setting to the proper level. The RSVD_H pins should be pulled High to the 3.3V rail with a 5 k Ω resistor. Depending upon the application the DVB_ASI pin may be tied off or driven.

There are three supply connections (see By Pass discussion and also Pin Descriptions for recommendations). The two main supplies are the 3.3V rail and the 2.5V rail. There is also a 3.3V connection for the PLL circuitry.

There are multiple Ground connections for the device. The main ground connection for the SER is through the large center DAP pad. This **must** be connected to ground for proper device operation. In addition, multiple other inputs are required to be connected to ground as show in the figure and listed in the Pin Description table.

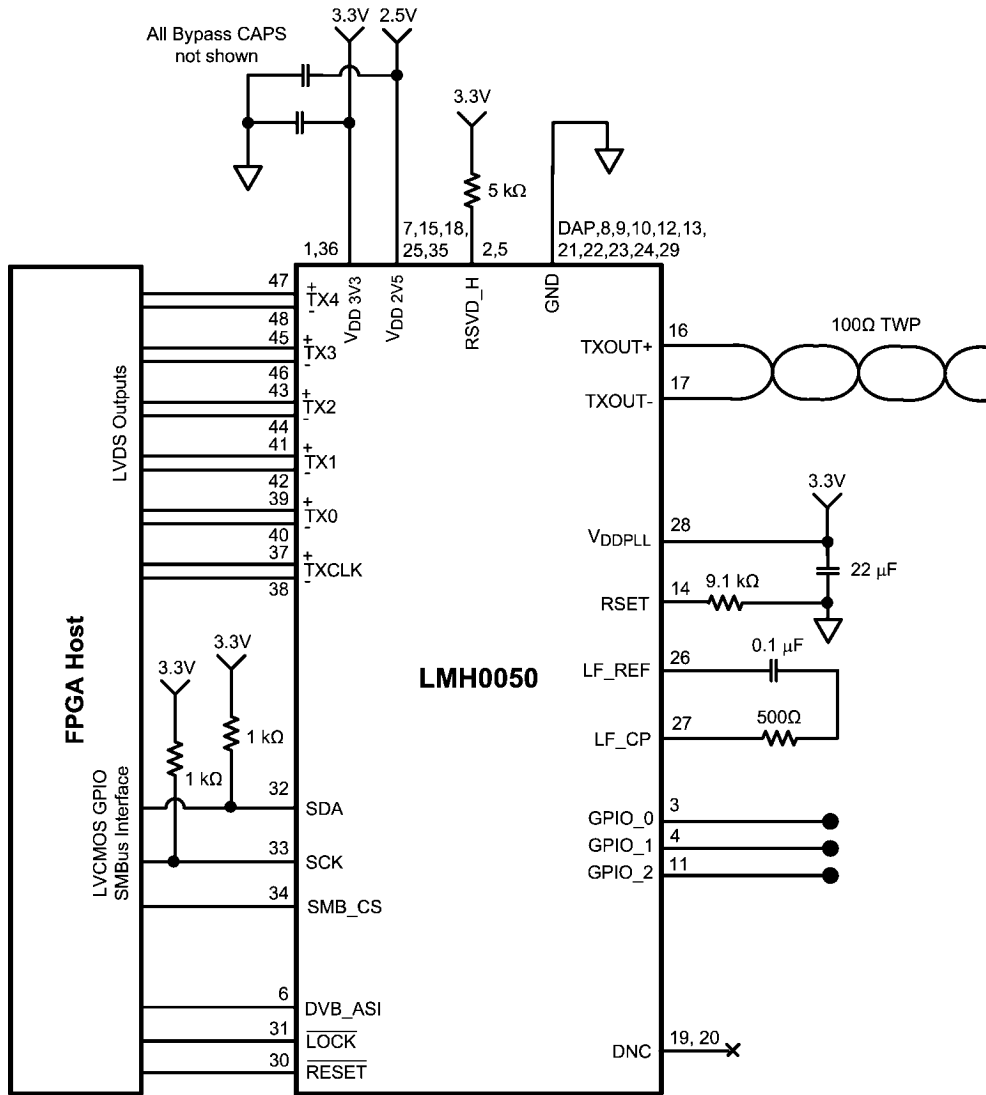

30017013

FIGURE 14. Typical LMH0050 CML Application Circuit

SERIAL JITTER OPTIMIZATION

The SER is capable of very low jitter operation, however it is dependent on the TXCLK provided by the host in order to operate, and depending on the quality of the TXCLK provided, the SER output jitter may not be as low as it could be.

The SER includes circuitry to filter out any TXCLK jitter at frequencies above 1MHz (see [Figure 15](#)), however, for frequencies below 100 kHz, any jitter that is in the TXCLK is passed directly through to the serialized output.

In most cases, passing the TXCLK through the FPGA will add high frequency noise to the signal, which will be filtered out by the SER, resulting in a clean output, however for better jitter performance, it is best to minimize the noise that is on the TXCLK that is provided to the SER. This can be done by careful routing of the CLK signals, both within the FPGA and on the board.

Very clean clocks can be derived from video reference signals through the use of the LMH1981 Sync Separator and the LMH1982 Clock Generator products from National Semiconductor. These products allow low jitter video frequency clocks to be generated either independently, or phase locked to a video reference signal.

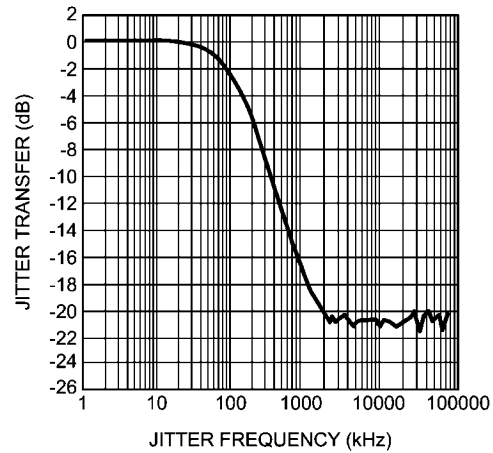

30017014

FIGURE 15. SER Jitter Transfer Function

Register Descriptions

The following table provides details on the device's configuration registers.

SER Register Detail Table

ADD 'h	Name	Bits	Field	R/W	Default	Description
00	device_identification	The seven MSBs of this register define the SMBus address for the device – the default value is 0x57'h, but this may be overwritten. The LSB of this register must always be '0' Note that since the address is shifted over by 1 bit, some systems may address the 57'h as AE'h.				
		7:1	device id	r/w	57'h	SMBus device ID
		0	Reserved		0'b	
01	reset	If a '1' is written to bit 0 (LSB) of this register the device will do a soft reset, restoring it's internal state to the same as at powerup except device_id register. Once the reset operation is complete, the value in this register is reset to '0' Bit 4 of this register has a default of 0, if a '1' is written to this location it will disable the analog output buffer of the device, allowing for some power savings.				
		7:5	Reserved			
		4	Analog Dis	r/w	0'b	Disables Analog
		3:1	Reserved			
		0	sw_rst	r/w	0'b	software reset
02	GPIO_0 Configuration	This register configures GPIO_0. Note, if this pin is to be used as an input, then the output must be TRI-STATE (bit[0]='0') and if used as an output, then the input buffer must be disabled (bit[1]='0').				
		7:4	GPIO_0_mode[3:0]	r/w	0000'b	0000: GPout register 0011: TXCLK LOS 0100: TXCLK Detect 0110: Power On Reset all others: reserved
		3:2	GPIO_0_ren[1:0]	r/w	01'b	00: pullup and pulldown disabled 01: pulldown enabled 10: pullup enabled 11: Reserved
		1	GPIO_0_sleepz	r/w	0'b	0: input buffer disabled 1: input buffer enabled
		0	GPout0 enable	r/w	1'b	0: output TRI-STATE 1: output enabled

ADD 'h	Name	Bits	Field	R/W	Default	Description
03	GPIO_1 Configuration	This register configures GPIO_1. Note, if this pin is to be used as an input, then the output must be TRI-STATE (bit[0]='0') and if used as an output, then the input buffer must be disabled (bit[1]='0').				
		7:4	GPIO_1_mode[3:0]	r/w	0000'b	0000: Power On Reset 0001: GPout register 0010: pll lock 0100: Data LOS [0] 0101: Data LOS [1] 0110: Data LOS [2] 0111: Data LOS [3] 1000: Data LOS [4] all others: reserved
		3:2	GPIO_1_ren[1:0]	r/w	01'b	00: pullup and pulldown disabled 01: pulldown enabled 10: pullup enabled 11: Reserved
		1	GPIO_1_sleepz	r/w	0'b	0: input buffer disabled 1: input buffer enabled
		0	GPout1 enable	r/w	1'b	0: output in TRI-STATE mode 1: output enabled
04	GPIO_2 Configuration	This register configures GPIO_2. Note, if this pin is to be used as an input, then the output must be TRI-STATE (bit[0]='0') and if used as an output, then the input buffer must be disabled (bit[1]='0').				
		7:4	GPIO_2_mode[3:0]	r/w	0000'b	0000: GPout register 0001: always on out 0010: parallel to serial clk out 0011: parallel clock output 0100: TXCLK Digital out all others: reserved
		3:2	GPIO_2_ren[1:0]	r/w	01'b	00: pullup and pulldown disabled 01: pulldown enabled 10: pullup enabled 11: Reserved
		1	GPIO_2_sleepz	r/w	0'b	0: input buffer disabled 1: input buffer enabled
		0	GPout2 enable	r/w	0'b	0: output TRI-STATEd 1: output enabled
05	GP INPUT	If any of the GPIO pins are configured as inputs, then reading from this register provides the values on those input pins.				
		7:3	Reserved			
		2		r		input data on GPIO_2
		1		r		input data on GPIO_1
		0		r		input data on GPIO_0
06	GP OUTPUT	If the GPIO pins are configured as general purpose output pins, then writing to this register has the effect of transferring the bits in this register to the output buffers of the appropriate GPIO pins.				
		7:3	Reserved			
		2		r/w	0'b	output data on GPIO_2
		1		r/w	0'b	output data on GPIO_1
		0		r/w	0'b	output data on GPIO_0
07-10	Reserved					

ADD 'h	Name	Bits	Field	R/W	Default	Description
11	DVB_ASI Idle_A	When in DVB-ASI mode, idle characters are inserted into the datastream when there is no valid data to transmit. The idle character default is K28.5 but if desired, that can be redefined via this register pair.				
		7:0		r/w	BC'h	K28.5 Idle character used for DVB_ASI
12	DVB_ASI Idle_B	DVB-ASI mode, idle character LSBs				
		7:2	Reserved			
		1:0		r/w	01'b	K28.5 Idle character used for DVB_ASI
13-1C	Reserved					
1D	Device Type	Reading from this register will return an 8 bit value which indicates which product from the SER family is being addressed				
		7:0	Device	r		xx1xxx00 for the LMH0340 xx1xxx01 for the LMH0040 xx1xxx10 for the LMH0070 xx0xxx01 for the LMH0050
1E-20	Reserved					
21	Mode	This register returns the mode that the device is operating in.				
		7:2	Reserved			
		1:0		r/w		11 = DVB ASI mode 01, 10, 00 = SDI mode
22	DVB_ASI Override	In normal operation, the DVB_ASI mode is selected via the external pin. By setting the 0 bit in this register, the function of this pin is overridden, and the mode is set via register 21'h instead. After setting this bit, a channel reset must be executed via reg 0x26h, bit 7				
		7:1	Reserved			
		0		r/w	0'b	1: contents of register 21h will override the DVB_ASI pin 0: Pin control
23	Reserved					
24	LVDS Clock Delay Bypass	This register selects of the TXCLK delay adjust is enabled or bypassed.				
		7		r/w	0'b	1: Bypasses TXCLK delay 0: Delay Enabled
		6:0	Reserved			
25	Reserved					
26	Powerdown	Individual bits from this register can power down different parts of the SER – to place the part into a low power standby mode, write a '0' to this register.				
		7	channel reset	r/w	0'b	Used to reset the channel, needed when changing between DVB_ASI mode and normal operating mode via SMBus
		6:0	Powerdown	r/w	0x3Fh	for normal operation, write x011 1111b to this register. For low power mode write x100 0000b to the register.

ADD 'h	Name	Bits	Field	R/W	Default	Description
27	Event Disable	The SER keeps counts of various types of events. These include FIFO over/underflows, and loss of the input signals or clocks. This register allows the user to mask these errors from being counted.				
		7:5	Reserved			
		4	PLL_CLK_disable	r/w	0'b	1: Clock Error disabled 0: Clock Errors counted
		3	fifo_error_disable	r/w	0'b	1: FIFO Errors ignored 0: FIFO Errors counted
		2	TXCLK_detect_disable	r/w	0'b	1: TXCLK Detect Errors ignored 0: TXCLK Detect Errors counted
		1	CLK_LOS_disable	r/w	0'b	1: CLK_LOS Errors ignored 0: CLK_LOS Errors counted
		0	Data_LOS_disable	r/w	0'b	1: Data_LOS Errors ignored 0: Data_LOS Errors counted
28	LVDS LOS Override Operation	These bits are used to force the LOS indicator regardless of the input signal level on the LVDS pins.				
		7:2	Reserved			
		1	LVDS Preset LOS	r/w	0'b	LVDS Preset LOS 1: Forces LOS to be Low 0: normal mode
		0	LVDS Reset LOS	r/w	0'b	LVDS Reset LOS (has priority over Preset) 1: Forces LOS to be High 0: normal mode
29	LOS Status	Reading the LOS status register will provide a byte which has six bits which represent the presence or absence of a signal at each of the LVDS inputs to the SER.				
		7:6	Reserved			
		5	LOS_CLK	r	0'b	1: No clock present on TXCLK 0: Clock present
		4:0	LOS_Data	r	0'b	1: No data present 0: Data Present(one bit per TX channel)
2A	Event Status	The event status register has two user readable bits which indicate if the device is locked, and if there is a signal present on the TXCLK input.				
		7:4	Reserved			
		3	TXCLK_detect	r	0'b	1: TXCLK detected 0: TXCLK not detected
		2	PLL_lock	r	0'b	1: PLL locked 0: PLL not locked
		1:0	Reserved			
2B-2D	Reserved					
2E	Reverse Bit Order	This bit can be used to reverse the serialization order, however it will only work properly when the device is NOT in DVB_ASI mode				
		7	Reserved			
		6	Reverse Bit Order	r/w	0'b	1: reverses serialization order 0: normal order
		5:0	Reserved			
2F	Reserved					

ADD 'h	Name	Bits	Field	R/W	Default	Description
30	CLK_Delay	The three msbs from this register are used to insert a programmable delay into the TXCLK path, if the host FPGA does not provide adequate setup and hold times for the SER, this register can be used to shift the window in 125ps increments.				
		7:5	TCLK Delay	r/w	011'b	000'b is minimum delay setting, 111'b is maximum delay setting, each step is approx 125ps
		4:0	Reserved			

Connection Diagram

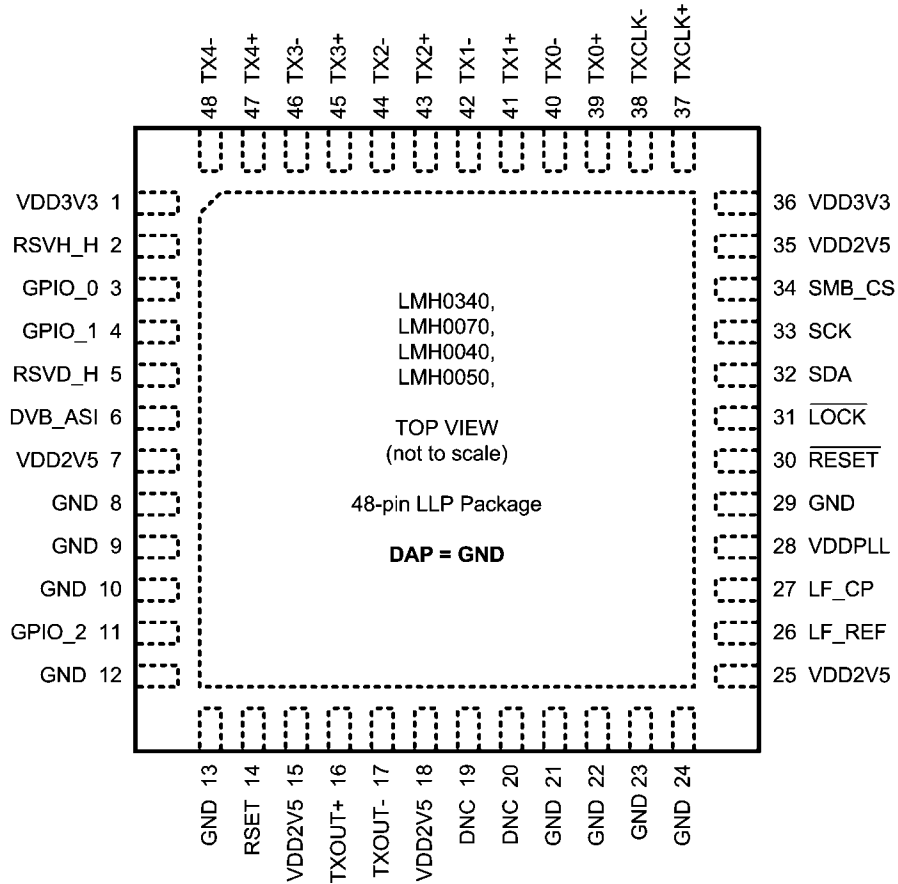

30017010

FIGURE 16. Connection Diagram for 48L LLP Package

Ordering Information

NSID	Speed	Cable Driver	Units per T&R	Package
LMH0340SQ	3G / HD / SD	SMPTE	1,000	SQA48A
LMH0340SQX			2,500	
LMH0340SQE			250	
LMH0040SQ	HD / SD	SMPTE	1,000	SQA48A
LMH0040SQX			2,500	
LMH0040SQE			250	
LMH0070SQ	SD	SMPTE	1,000	SQA48A
LMH0070SQX			2,500	
LMH0070SQE			250	
LMH0050SQ	HD / SD	CML	1,000	SQA48A
LMH0050SQX			2,500	
LMH0050SQE			250	

Physical Dimensions inches (millimeters) unless otherwise noted

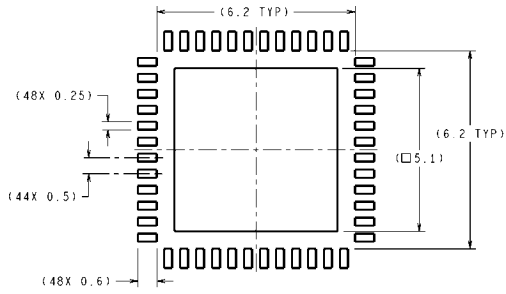

DIMENSIONS ARE IN MILLIMETERS
DIMENSIONS IN () FOR REFERENCE ONLY

RECOMMENDED LAND PATTERN

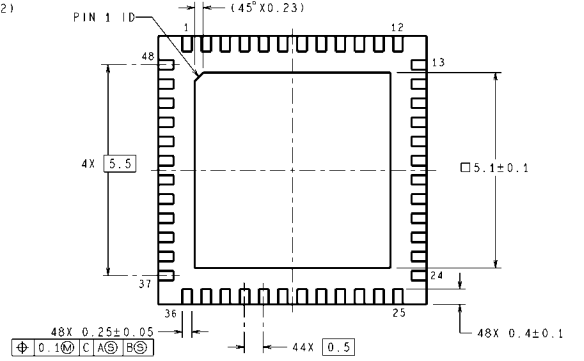
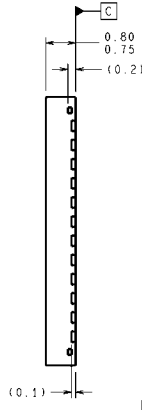
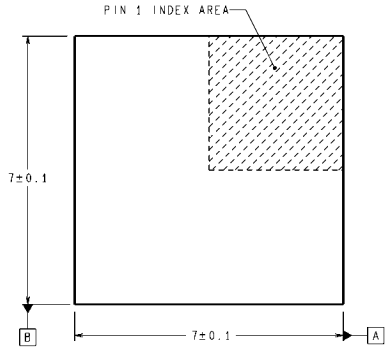

SQA48A (Rev B)

48-Lead LLP Plastic Quad Package
NS Package Number SQA48A

Notes

Notes

For more National Semiconductor product information and proven design tools, visit the following Web sites at:

Products		Design Support	
Amplifiers	www.national.com/amplifiers	WEBENCH® Tools	www.national.com/webench
Audio	www.national.com/audio	App Notes	www.national.com/appnotes
Clock and Timing	www.national.com/timing	Reference Designs	www.national.com/refdesigns
Data Converters	www.national.com/adc	Samples	www.national.com/samples
Interface	www.national.com/interface	Eval Boards	www.national.com/evalboards
LVDS	www.national.com/lvds	Packaging	www.national.com/packaging
Power Management	www.national.com/power	Green Compliance	www.national.com/quality/green
Switching Regulators	www.national.com/switchers	Distributors	www.national.com/contacts
LDOs	www.national.com/ldo	Quality and Reliability	www.national.com/quality
LED Lighting	www.national.com/led	Feedback/Support	www.national.com/feedback
Voltage Reference	www.national.com/vref	Design Made Easy	www.national.com/easy
PowerWise® Solutions	www.national.com/powerwise	Solutions	www.national.com/solutions
Serial Digital Interface (SDI)	www.national.com/sdi	Mil/Aero	www.national.com/milaero
Temperature Sensors	www.national.com/tempensors	SolarMagic™	www.national.com/solarmagic
Wireless (PLL/VCO)	www.national.com/wireless	PowerWise® Design University	www.national.com/training

THE CONTENTS OF THIS DOCUMENT ARE PROVIDED IN CONNECTION WITH NATIONAL SEMICONDUCTOR CORPORATION ("NATIONAL") PRODUCTS. NATIONAL MAKES NO REPRESENTATIONS OR WARRANTIES WITH RESPECT TO THE ACCURACY OR COMPLETENESS OF THE CONTENTS OF THIS PUBLICATION AND RESERVES THE RIGHT TO MAKE CHANGES TO SPECIFICATIONS AND PRODUCT DESCRIPTIONS AT ANY TIME WITHOUT NOTICE. NO LICENSE, WHETHER EXPRESS, IMPLIED, ARISING BY ESTOPPEL OR OTHERWISE, TO ANY INTELLECTUAL PROPERTY RIGHTS IS GRANTED BY THIS DOCUMENT.

TESTING AND OTHER QUALITY CONTROLS ARE USED TO THE EXTENT NATIONAL DEEMS NECESSARY TO SUPPORT NATIONAL'S PRODUCT WARRANTY. EXCEPT WHERE MANDATED BY GOVERNMENT REQUIREMENTS, TESTING OF ALL PARAMETERS OF EACH PRODUCT IS NOT NECESSARILY PERFORMED. NATIONAL ASSUMES NO LIABILITY FOR APPLICATIONS ASSISTANCE OR BUYER PRODUCT DESIGN. BUYERS ARE RESPONSIBLE FOR THEIR PRODUCTS AND APPLICATIONS USING NATIONAL COMPONENTS. PRIOR TO USING OR DISTRIBUTING ANY PRODUCTS THAT INCLUDE NATIONAL COMPONENTS, BUYERS SHOULD PROVIDE ADEQUATE DESIGN, TESTING AND OPERATING SAFEGUARDS.

EXCEPT AS PROVIDED IN NATIONAL'S TERMS AND CONDITIONS OF SALE FOR SUCH PRODUCTS, NATIONAL ASSUMES NO LIABILITY WHATSOEVER, AND NATIONAL DISCLAIMS ANY EXPRESS OR IMPLIED WARRANTY RELATING TO THE SALE AND/OR USE OF NATIONAL PRODUCTS INCLUDING LIABILITY OR WARRANTIES RELATING TO FITNESS FOR A PARTICULAR PURPOSE, MERCHANTABILITY, OR INFRINGEMENT OF ANY PATENT, COPYRIGHT OR OTHER INTELLECTUAL PROPERTY RIGHT.

LIFE SUPPORT POLICY

NATIONAL'S PRODUCTS ARE NOT AUTHORIZED FOR USE AS CRITICAL COMPONENTS IN LIFE SUPPORT DEVICES OR SYSTEMS WITHOUT THE EXPRESS PRIOR WRITTEN APPROVAL OF THE CHIEF EXECUTIVE OFFICER AND GENERAL COUNSEL OF NATIONAL SEMICONDUCTOR CORPORATION. As used herein:

Life support devices or systems are devices which (a) are intended for surgical implant into the body, or (b) support or sustain life and whose failure to perform when properly used in accordance with instructions for use provided in the labeling can be reasonably expected to result in a significant injury to the user. A critical component is any component in a life support device or system whose failure to perform can be reasonably expected to cause the failure of the life support device or system or to affect its safety or effectiveness.

National Semiconductor and the National Semiconductor logo are registered trademarks of National Semiconductor Corporation. All other brand or product names may be trademarks or registered trademarks of their respective holders.

Copyright© 2009 National Semiconductor Corporation

For the most current product information visit us at www.national.com



National Semiconductor Americas Technical Support Center
Email: support@nsc.com
Tel: 1-800-272-9959

National Semiconductor Europe Technical Support Center
Email: europe.support@nsc.com

National Semiconductor Asia Pacific Technical Support Center
Email: ap.support@nsc.com

National Semiconductor Japan Technical Support Center
Email: jpn.feedback@nsc.com