

LMH0001 SMPTE 259M / 344M Serial Digital Cable Driver

Check for Samples: [LMH0001](#)

FEATURES

- **SMPTE 259M and SMPTE 344M Compliant**
- **Data Rates to 540 Mbps**
- **Supports DVB-ASI at 270 Mbps**
- **Differential Input**
- **75Ω Differential Output**
- **Adjustable Output Amplitude**
- **Single 3.3V Supply Operation**
- **Industrial Temperature Range: –40°C to +85°C**
- **125mW Typical Power Consumption**
- **16–pin WQFN Package**
- **Footprint Compatible with the LMH0002SQ and the GS9078A.**

DESCRIPTION

The LMH0001 SMPTE 259M / 344M Serial Digital Cable Driver is designed for use in SMPTE 259M / 344M serial digital video applications. The LMH0001 drives 75Ω transmission lines (Belden 8281, Belden 1694A or equivalent) at data rates up to 540 Mbps.

The output voltage swing of the LMH0001 is adjustable via a single external resistor.

The LMH0001 is powered from a single 3.3V supply. Power consumption is typically 125mW. The LMH0001 is available in a 16-pin WQFN package.

APPLICATIONS

- **SMPTE 259M and SMPTE 344M Serial Digital Interfaces**
- **DVB-ASI Applications**
- **Sonet/SDH and ATM Interfaces**
- **Digital Routers and Switches**
- **Distribution Amplifiers**
- **Buffer Applications**
- **Set Top Boxes**
- **Security Cameras**

Typical Application

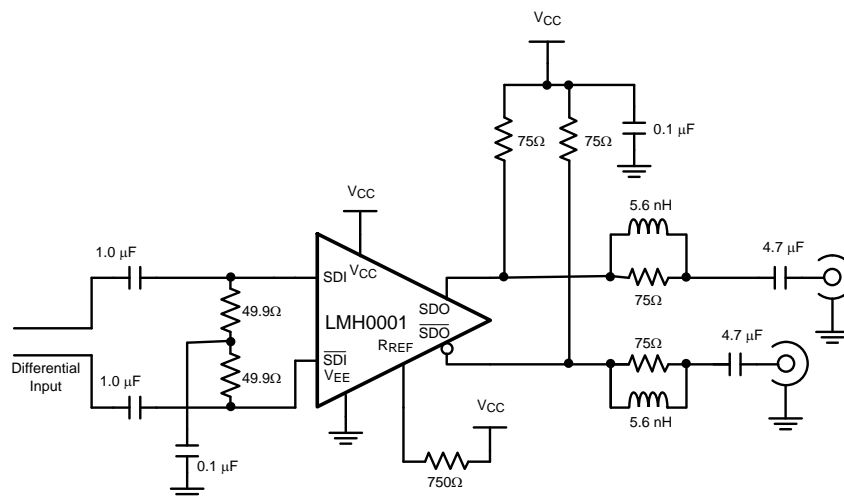

Please be aware that an important notice concerning availability, standard warranty, and use in critical applications of Texas Instruments semiconductor products and disclaimers thereto appears at the end of this data sheet.

All trademarks are the property of their respective owners.



These devices have limited built-in ESD protection. The leads should be shorted together or the device placed in conductive foam during storage or handling to prevent electrostatic damage to the MOS gates.

Absolute Maximum Ratings ⁽¹⁾

Supply Voltage:	-0.5V to 3.6V
Input Voltage (all inputs)	-0.3V to $V_{CC}+0.3V$
Output Current	28mA
Storage Temperature Range	-65°C to +150°C
Junction Temperature	+150°C
Lead Temperature (Soldering 4 Sec)	+260°C
Package Thermal Resistance θ_{JA} 16-pin WQFN θ_{JC} 16-pin WQFN	+78.9°C/W +42.7°C/W
ESD Rating (HBM)	5kV
ESD Rating (MM)	250V

- (1) Absolute Maximum Ratings are those parameter values beyond which the life and operation of the device cannot be ensured. The stating herein of these maximums shall not be construed to imply that the device can or should be operated at or beyond these values. The table of [Electrical Characteristics](#) specifies acceptable device operating conditions.

Recommended Operating Conditions

Supply Voltage ($V_{CC} - V_{EE}$):	3.3V $\pm 5\%$
Operating Free Air Temperature (T_A)	-40°C to +85°C

DC Electrical Characteristics

Over Supply Voltage and Operating Temperature ranges, unless otherwise specified ⁽¹⁾⁽²⁾.

Parameter		Test Conditions	Reference	Min	Typ	Max	Unit
V_{CMIN}	Input Common Mode Voltage		SDI, \overline{SDI}	1.6 + $V_{SDI}/2$		$V_{CC} -$ $V_{SDI}/2$	V
V_{SDI}	Input Voltage Swing	Differential		100		2000	mV _{P-P}
V_{CMOUT}	Output Common Mode Voltage		SDO, \overline{SDO}		$V_{CC} -$ V_{SDO}		V
V_{SDO}	Output Voltage Swing	Single-ended, 75Ω load, $R_{REF} = 750\Omega$ 1%		750	800	850	mV _{P-P}
		Single-ended, 75Ω load, $R_{REF} = 590\Omega$ 1%		900	1000	1100	mV _{P-P}
I_{CC}	Supply Current				⁽³⁾ 38	43	mA

- (1) Current flow into device pins is defined as positive. Current flow out of device pins is defined as negative. All voltages are stated referenced to $V_{EE} = 0$ Volts.
(2) Typical values are stated for $V_{CC} = +3.3V$ and $T_A = +25^\circ C$.
(3) Maximum I_{CC} is measured at $V_{CC} = +3.465V$ and $T_A = +70^\circ C$.

AC Electrical Characteristics

Over Supply Voltage and Operating Temperature ranges, unless otherwise specified ⁽¹⁾.

Parameter		Test Conditions	Reference	Min	Typ	Max	Unit
DR _{SDI}	Input Data Rate		⁽²⁾ SDI, $\overline{\text{SDI}}$			540	Mbps
t _{jit}	Additive Jitter	270 Mbps	SDO, $\overline{\text{SDO}}$		18		pSp,p
t _r , t _f	Output Rise Time, Fall Time	20% – 80%		400	560	800	ps
	Mismatch in Rise/Fall Time	⁽²⁾				30	ps
	Duty Cycle Distortion	⁽²⁾				100	ps
t _{OS}	Output Overshoot	⁽²⁾				8	%
RL _{SDO}	Output Return Loss			⁽³⁾ 15	20		dB

(1) Typical values are stated for V_{CC} = +3.3V and T_A = +25°C.

(2) Specification is ensured by characterization.

(3) Output return loss is dependent on board design. The LMH0001 meets this specification on the SD001SQ evaluation board from 5MHz to 1.5GHz.

CONNECTION DIAGRAM

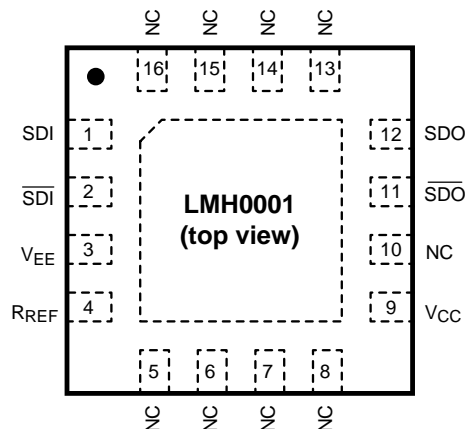

Figure 1. 16-Pin WQFN Package
See Package Number RUM0016A

PIN DESCRIPTIONS

SOIC Pin No.	WQFN Pin No.	Name	Description
1	1	SDI	Serial data true input.
2	2	$\overline{\text{SDI}}$	Serial data complement input.
3	3	V _{EE}	Negative power supply (ground).
4	4	R _{REF}	Output driver level control. Connect a resistor to V _{CC} to set output voltage swing.
5	9	V _{CC}	Positive power supply (+3.3V).
7	11	$\overline{\text{SDO}}$	Serial data complement output.
8	12	SDO	Serial data true output.
—	5, 6, 7, 8, 10, 13, 14, 15, 16	NC	No connect.
—	DAP	V _{EE}	Connect exposed DAP to negative power supply (ground).

DEVICE OPERATION

INPUT INTERFACING

The LMH0001 accepts either differential or single-ended input. The inputs are self-biased, allowing for simple AC or DC coupling. DC-coupled inputs must be kept within the specified common-mode range. $\overline{\text{SDI}}$ and $\overline{\text{SDI}}$ are self-biased at approximately 2.1V with $V_{CC} = 3.3\text{V}$. Figure 2 shows the differential input stage for $\overline{\text{SDI}}$ and $\overline{\text{SDI}}$.

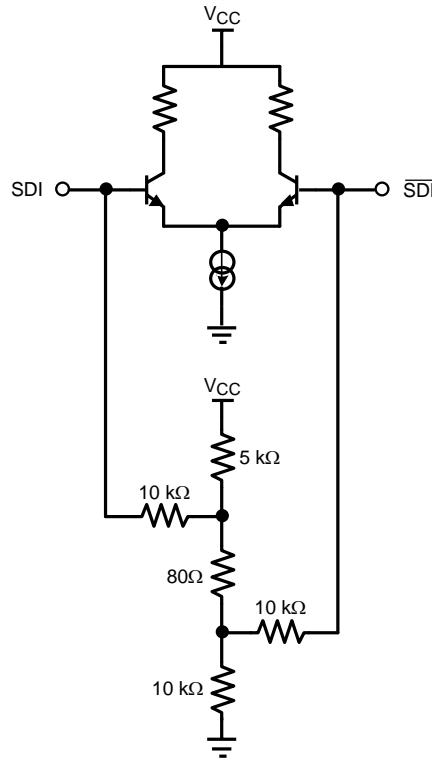

Figure 2. Differential Input Stage for $\overline{\text{SDI}}$ and $\overline{\text{SDI}}$.

OUTPUT INTERFACING

The LMH0001 uses current mode outputs. Single-ended output levels are 800 mV_{P-P} into 75Ω AC-coupled coaxial cable (with $R_{REF} = 750\Omega$). Output level is controlled by the value of the R_{REF} resistor connected between the R_{REF} pin and V_{CC} .

The R_{REF} resistor should be placed as close as possible to the R_{REF} pin. In addition, the copper in the plane layers below the R_{REF} network should be removed to minimize parasitic capacitance.

REVISION HISTORY

Changes from Revision B (April 2013) to Revision C	Page
• Changed layout of National Data Sheet to TI format	4

PACKAGING INFORMATION

Orderable Device	Status (1)	Package Type	Package Drawing	Pins	Package Qty	Eco Plan (2)	Lead/Ball Finish (6)	MSL Peak Temp (3)	Op Temp (°C)	Device Marking (4/5)	Samples
LMH0001SQ/NOPB	ACTIVE	WQFN	RUM	16	1000	Green (RoHS & no Sb/Br)	CU SN	Level-1-260C-UNLIM	-40 to 85	L001	Samples
LMH0001SQE/NOPB	ACTIVE	WQFN	RUM	16	250	Green (RoHS & no Sb/Br)	CU SN	Level-1-260C-UNLIM	-40 to 85	L001	Samples

(1) The marketing status values are defined as follows:

ACTIVE: Product device recommended for new designs.

LIFEBUY: TI has announced that the device will be discontinued, and a lifetime-buy period is in effect.

NRND: Not recommended for new designs. Device is in production to support existing customers, but TI does not recommend using this part in a new design.

PREVIEW: Device has been announced but is not in production. Samples may or may not be available.

OBsolete: TI has discontinued the production of the device.

(2) Eco Plan - The planned eco-friendly classification: Pb-Free (RoHS), Pb-Free (RoHS Exempt), or Green (RoHS & no Sb/Br) - please check <http://www.ti.com/productcontent> for the latest availability information and additional product content details.

TBD: The Pb-Free/Green conversion plan has not been defined.

Pb-Free (RoHS): TI's terms "Lead-Free" or "Pb-Free" mean semiconductor products that are compatible with the current RoHS requirements for all 6 substances, including the requirement that lead not exceed 0.1% by weight in homogeneous materials. Where designed to be soldered at high temperatures, TI Pb-Free products are suitable for use in specified lead-free processes.

Pb-Free (RoHS Exempt): This component has a RoHS exemption for either 1) lead-based flip-chip solder bumps used between the die and package, or 2) lead-based die adhesive used between the die and leadframe. The component is otherwise considered Pb-Free (RoHS compatible) as defined above.

Green (RoHS & no Sb/Br): TI defines "Green" to mean Pb-Free (RoHS compatible), and free of Bromine (Br) and Antimony (Sb) based flame retardants (Br or Sb do not exceed 0.1% by weight in homogeneous material)

(3) MSL, Peak Temp. - The Moisture Sensitivity Level rating according to the JEDEC industry standard classifications, and peak solder temperature.

(4) There may be additional marking, which relates to the logo, the lot trace code information, or the environmental category on the device.

(5) Multiple Device Markings will be inside parentheses. Only one Device Marking contained in parentheses and separated by a "~" will appear on a device. If a line is indented then it is a continuation of the previous line and the two combined represent the entire Device Marking for that device.

(6) Lead/Ball Finish - Orderable Devices may have multiple material finish options. Finish options are separated by a vertical ruled line. Lead/Ball Finish values may wrap to two lines if the finish value exceeds the maximum column width.

Important Information and Disclaimer: The information provided on this page represents TI's knowledge and belief as of the date that it is provided. TI bases its knowledge and belief on information provided by third parties, and makes no representation or warranty as to the accuracy of such information. Efforts are underway to better integrate information from third parties. TI has taken and continues to take reasonable steps to provide representative and accurate information but may not have conducted destructive testing or chemical analysis on incoming materials and chemicals. TI and TI suppliers consider certain information to be proprietary, and thus CAS numbers and other limited information may not be available for release.

In no event shall TI's liability arising out of such information exceed the total purchase price of the TI part(s) at issue in this document sold by TI to Customer on an annual basis.

TAPE AND REEL INFORMATION

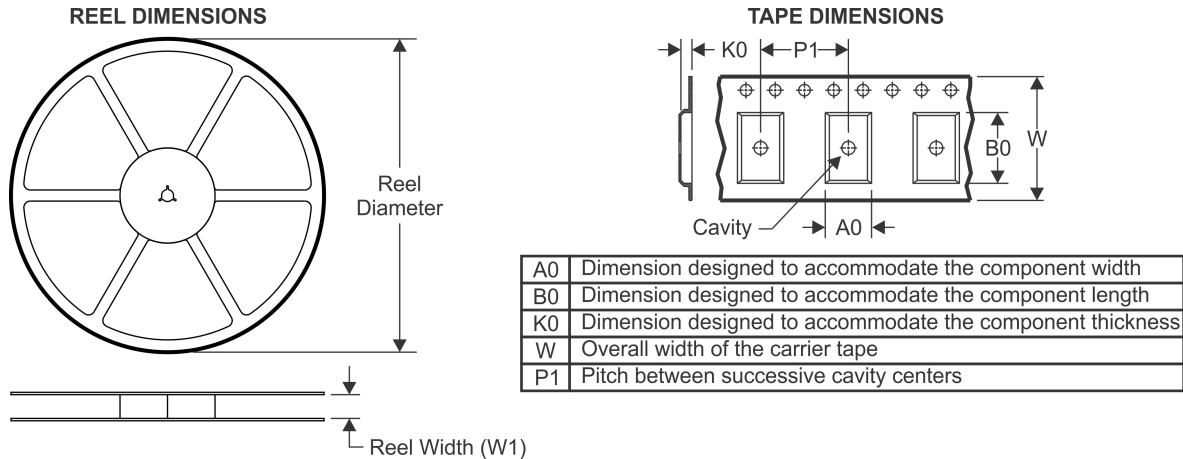

QUADRANT ASSIGNMENTS FOR PIN 1 ORIENTATION IN TAPE



*All dimensions are nominal

Device	Package Type	Package Drawing	Pins	SPQ	Reel Diameter (mm)	Reel Width W1 (mm)	A0 (mm)	B0 (mm)	K0 (mm)	P1 (mm)	W (mm)	Pin1 Quadrant
LMH0001SQ/NOPB	WQFN	RUM	16	1000	178.0	12.4	4.3	4.3	1.3	8.0	12.0	Q1
LMH0001SQE/NOPB	WQFN	RUM	16	250	178.0	12.4	4.3	4.3	1.3	8.0	12.0	Q1

TAPE AND REEL BOX DIMENSIONS

*All dimensions are nominal

Device	Package Type	Package Drawing	Pins	SPQ	Length (mm)	Width (mm)	Height (mm)
LMH0001SQ/NOPB	WQFN	RUM	16	1000	210.0	185.0	35.0
LMH0001SQE/NOPB	WQFN	RUM	16	250	210.0	185.0	35.0

RUM0016A

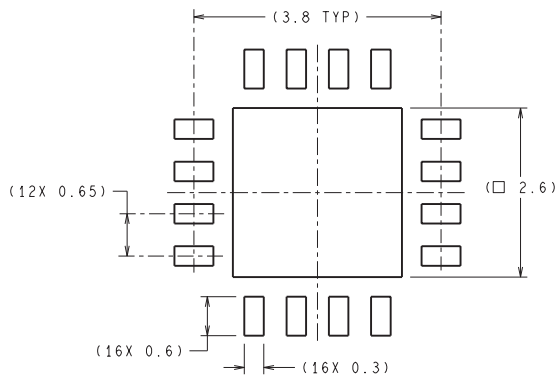

RECOMMENDED LAND PATTERN

DIMENSIONS ARE IN MILLIMETERS
DIMENSIONS IN () FOR REFERENCE ONLY

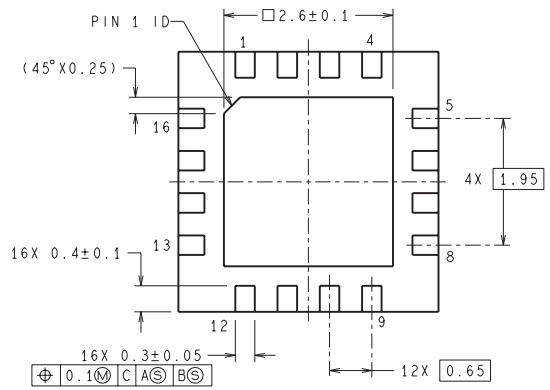
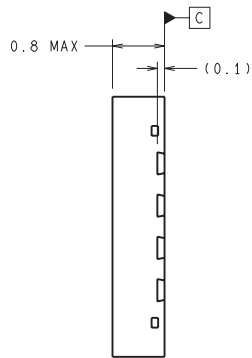
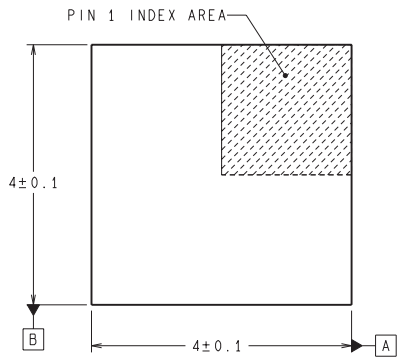
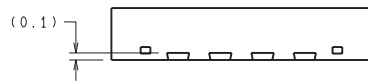

SQB16A (Rev A)

IMPORTANT NOTICE

Texas Instruments Incorporated and its subsidiaries (TI) reserve the right to make corrections, enhancements, improvements and other changes to its semiconductor products and services per JESD46, latest issue, and to discontinue any product or service per JESD48, latest issue. Buyers should obtain the latest relevant information before placing orders and should verify that such information is current and complete. All semiconductor products (also referred to herein as "components") are sold subject to TI's terms and conditions of sale supplied at the time of order acknowledgment.

TI warrants performance of its components to the specifications applicable at the time of sale, in accordance with the warranty in TI's terms and conditions of sale of semiconductor products. Testing and other quality control techniques are used to the extent TI deems necessary to support this warranty. Except where mandated by applicable law, testing of all parameters of each component is not necessarily performed.

TI assumes no liability for applications assistance or the design of Buyers' products. Buyers are responsible for their products and applications using TI components. To minimize the risks associated with Buyers' products and applications, Buyers should provide adequate design and operating safeguards.

TI does not warrant or represent that any license, either express or implied, is granted under any patent right, copyright, mask work right, or other intellectual property right relating to any combination, machine, or process in which TI components or services are used. Information published by TI regarding third-party products or services does not constitute a license to use such products or services or a warranty or endorsement thereof. Use of such information may require a license from a third party under the patents or other intellectual property of the third party, or a license from TI under the patents or other intellectual property of TI.

Reproduction of significant portions of TI information in TI data books or data sheets is permissible only if reproduction is without alteration and is accompanied by all associated warranties, conditions, limitations, and notices. TI is not responsible or liable for such altered documentation. Information of third parties may be subject to additional restrictions.

Resale of TI components or services with statements different from or beyond the parameters stated by TI for that component or service voids all express and any implied warranties for the associated TI component or service and is an unfair and deceptive business practice. TI is not responsible or liable for any such statements.

Buyer acknowledges and agrees that it is solely responsible for compliance with all legal, regulatory and safety-related requirements concerning its products, and any use of TI components in its applications, notwithstanding any applications-related information or support that may be provided by TI. Buyer represents and agrees that it has all the necessary expertise to create and implement safeguards which anticipate dangerous consequences of failures, monitor failures and their consequences, lessen the likelihood of failures that might cause harm and take appropriate remedial actions. Buyer will fully indemnify TI and its representatives against any damages arising out of the use of any TI components in safety-critical applications.

In some cases, TI components may be promoted specifically to facilitate safety-related applications. With such components, TI's goal is to help enable customers to design and create their own end-product solutions that meet applicable functional safety standards and requirements. Nonetheless, such components are subject to these terms.

No TI components are authorized for use in FDA Class III (or similar life-critical medical equipment) unless authorized officers of the parties have executed a special agreement specifically governing such use.

Only those TI components which TI has specifically designated as military grade or "enhanced plastic" are designed and intended for use in military/aerospace applications or environments. Buyer acknowledges and agrees that any military or aerospace use of TI components which have **not** been so designated is solely at the Buyer's risk, and that Buyer is solely responsible for compliance with all legal and regulatory requirements in connection with such use.

TI has specifically designated certain components as meeting ISO/TS16949 requirements, mainly for automotive use. In any case of use of non-designated products, TI will not be responsible for any failure to meet ISO/TS16949.

Products

Audio	www.ti.com/audio
Amplifiers	amplifier.ti.com
Data Converters	dataconverter.ti.com
DLP® Products	www.dlp.com
DSP	dsp.ti.com
Clocks and Timers	www.ti.com/clocks
Interface	interface.ti.com
Logic	logic.ti.com
Power Mgmt	power.ti.com
Microcontrollers	microcontroller.ti.com
RFID	www.ti-rfid.com
OMAP Applications Processors	www.ti.com/omap
Wireless Connectivity	www.ti.com/wirelessconnectivity

Applications

Automotive and Transportation	www.ti.com/automotive
Communications and Telecom	www.ti.com/communications
Computers and Peripherals	www.ti.com/computers
Consumer Electronics	www.ti.com/consumer-apps
Energy and Lighting	www.ti.com/energy
Industrial	www.ti.com/industrial
Medical	www.ti.com/medical
Security	www.ti.com/security
Space, Avionics and Defense	www.ti.com/space-avionics-defense
Video and Imaging	www.ti.com/video

TI E2E Community

e2e.ti.com