

LM73 2.7-V, SOT-23, 11- to 14-Bit Digital Temperature Sensor With 2-Wire Interface

1 Features

- Single Address Pin Offers Choice of Three Selectable Addresses Per Version for a Total of Six Possible Addresses.
- SMBus and I²C-compatible Two-Wire Interface
- Supports 400-Khz Operation
- Shutdown Mode With One-shot Feature Available for Very Low Average Power Consumption
- Programmable Digital Temperature Resolution From 11 Bits to 14 Bits
- Fast Conversion Rate Ideal for Quick Power Up and Measuring Rapidly Changing Temperature
- Open-Drain ALERT Output Pin Goes Active When Temperature is Above a Programmed Temperature Limit
- Very Stable, Low-noise Digital Output
- UL Recognized Component
- **Key Specifications**
 - Supply Current
 - Operating
 - 320 μ A (Typical)
 - 495 μ A (Maximum)
 - Shutdown
 - 8 μ A (Maximum)
 - 1.9 μ A (Typical)
 - Temperature Accuracy
 - -10°C to 80°C : $\pm 1.0^{\circ}\text{C}$ (Maximum)
 - -25°C to 115°C : $\pm 1.5^{\circ}\text{C}$ (Maximum)
 - -40°C to 150°C : $\pm 2^{\circ}\text{C}$ (Maximum)
 - Resolution
 - 0.25°C to 0.03125°C
 - Conversion Time
 - 11-Bit (0.25°C): 14 ms (Maximum)
 - 14-Bit (0.03125°C): 112 ms (Maximum)

2 Applications

- Portable Electronics
- Notebook Computers
- Automotive
- System Thermal Management
- Office Electronics

3 Description

The LM73 is an integrated, digital-output temperature sensor featuring an incremental Delta-Sigma ADC with a two-wire interface that is compatible with the SMBus and I²C interfaces. The host can query the LM73 at any time to read temperature.

Available in a 6-pin SOT package, the LM73 occupies very little board area while operating over a wide temperature range (-40°C to 150°C) and providing $\pm 1^{\circ}\text{C}$ accuracy from -10°C to 80°C . The user can optimize between the conversion time and the sensitivity of the LM73 by programming it to report temperature in any of four different resolutions. Defaulting to 11-bit mode ($0.25^{\circ}\text{C}/\text{LSB}$), the LM73 measures temperature in a maximum time of 14 ms, making it ideal for applications that require temperature data very soon after power-up. In its maximum resolution, 14-bit mode ($0.03125^{\circ}\text{C}/\text{LSB}$), the LM73 is optimized to sense very small changes in temperature.

A single multi-level address line selects one of three unique device addresses. An open-drain ALERT output goes active when the temperature exceeds a programmable limit. Both the data and clock lines are filtered for excellent noise tolerance and reliable communication. Additionally, a time-out feature on the clock and data lines causes the LM73 to automatically reset these lines if either is held low for an extended time, thus exiting any bus lock-up condition without processor intervention.

Device Information⁽¹⁾

PART NUMBER	PACKAGE	BODY SIZE (NOM)
LM73	SOT (6)	2.90 mm x 1.60 mm

(1) For all available packages, see the orderable addendum at the end of the datasheet.

Typical Application

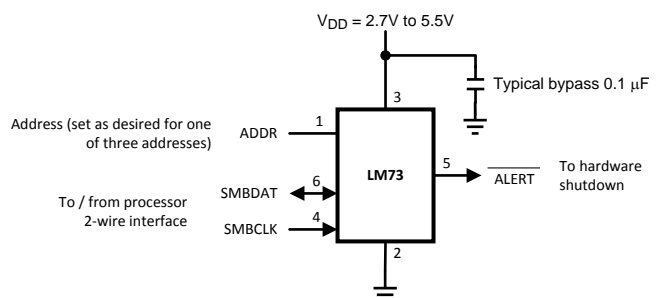

Table of Contents

1 Features 1 2 Applications 1 3 Description 1 4 Revision History 2 5 Pin Configuration and Functions 3 6 Specifications 4 6.1 Absolute Maximum Ratings 4 6.2 ESD Ratings 4 6.3 Recommended Operating Conditions 4 6.4 Thermal Information 4 6.5 Temperature-to-Digital Converter Characteristics..... 5 6.6 Logic Electrical Characteristics- Digital DC Characteristics 6 6.7 Logic Electrical Characteristics- SMBus Digital Switching Characteristics 7 6.8 Typical Characteristics 8 7 Detailed Description 9 7.1 Overview 9	7.2 Functional Block Diagram 9 7.3 Feature Description..... 9 7.4 Device Functional Modes..... 15 7.5 Register Map 16 8 Application and Implementation 20 8.1 Application Information..... 20 8.2 Typical Application 20 9 Power Supply Recommendations 22 10 Layout 22 10.1 Layout Guidelines 22 10.2 Layout Example 22 11 Device and Documentation Support 23 11.1 Community Resources..... 23 11.2 Trademarks 23 11.3 Electrostatic Discharge Caution..... 23 11.4 Glossary 23 12 Mechanical, Packaging, and Orderable Information 23
--	---

4 Revision History

Changes from Revision E (January 2015) to Revision F Page

- Changed Temperature Accuracy spec typo on the front page..... 1

Changes from Revision D (May 2009) to Revision E Page

- Added *Pin Configuration and Functions* section, *ESD Ratings* table, *Feature Description* section, *Device Functional Modes*, *Application and Implementation* section, *Power Supply Recommendations* section, *Layout* section, *Device and Documentation Support* section, and *Mechanical, Packaging, and Orderable Information* section 1

5 Pin Configuration and Functions

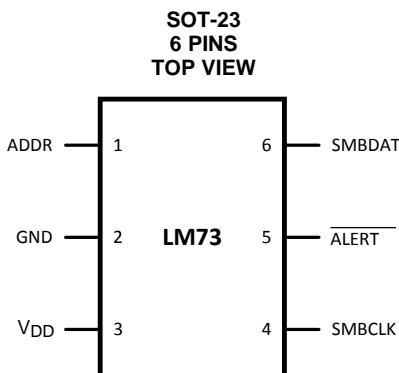

Pin Functions

PIN		TYPE	EQUIVALENT CIRCUIT	FUNCTION
NO.	NAME			
1	ADDR	CMOS Logic Input (three levels)		Address Select Input: One of three device addresses is selected by connecting to ground, left floating, or connecting to V_{DD} .
2	GND	Ground		Ground
3	V_{DD}	Power		Supply Voltage
4	SMBCLK	CMOS Logic Input		Serial Clock: SMBus clock signal. Operates up to 400 kHz. Low-pass filtered.
5	$\overline{\text{ALERT}}$	Open-Drain Output		Digital output which goes active whenever the measured temperature exceeds a programmable temperature limit.
6	SMBDAT	Open-Drain Input/Output		Serial Data: SMBus bi-directional data signal used to transfer serial data synchronous to the SMBCLK. Low-pass filtered.

6 Specifications

6.1 Absolute Maximum Ratings

 over operating free-air temperature range (unless otherwise noted)⁽¹⁾⁽²⁾

	MIN	NOM	MAX	UNIT
Supply Voltage	-0.3		V to 6	V
Voltage at SMBCLK and SMBDAT pins	-0.3 V to V		6	V
Voltage at All Other Pins	-0.3	(V _{DD} + 0.5)	6	V
Input Current at Any Pin ⁽³⁾			±5	mA
Storage Temperature, T _{stg}	-65		150	°C

- (1) Stresses beyond those listed under *Absolute Maximum Ratings* may cause permanent damage to the device. These are stress ratings only, which do not imply functional operation of the device at these or any other conditions beyond those indicated under *Recommended Operating Conditions*. Exposure to absolute-maximum-rated conditions for extended periods may affect device reliability.
- (2) Soldering process must comply with Texas Instruments' Reflow Temperature Profile specifications. Refer to www.ti.com/packaging. Reflow temperature profiles are different for lead-free and non-lead-free packages.
- (3) When the input voltage (V_I) at any pin exceeds the power supplies (V_I < GND or V_I > V_{DD}), the current at that pin should be limited to 5 mA.

6.2 ESD Ratings

		VALUE	UNIT
V _(ESD) Electrostatic discharge	Human-body model (HBM), per ANSI/ESDA/JEDEC JS-001 ⁽¹⁾	±2000	V
	Machine Model	±200	

- (1) JEDEC document JEP155 states that 500-V HBM allows safe manufacturing with a standard ESD control process.

6.3 Recommended Operating Conditions

over operating free-air temperature range (unless otherwise noted)

	MIN	MAX	UNIT
LM73CIMK-0, LM73CIMK-1	-40	150	°C
Supply Voltage Range (V _{DD})	2.7	5.5	V

6.4 Thermal Information

THERMAL METRIC ⁽¹⁾		LM73	UNIT
		DDC (SOT)	
		6 PINS	
R _{θJA}	Junction-to-ambient thermal resistance	224	°C/W
R _{θJC(top)}	Junction-to-case (top) thermal resistance	89	

- (1) For more information about traditional and new thermal metrics, see the *IC Package Thermal Metrics* application report, [SPRA953](http://www.ti.com/lit/zip/Spra953).

6.5 Temperature-to-Digital Converter Characteristics

Unless otherwise noted, these specifications apply for $V_{DD} = 2.7\text{ V}$ to 5.5 V . All limits $T_A = T_J = 25^\circ\text{C}$, unless otherwise noted. T_A is the ambient temperature. T_J is the junction temperature.

PARAMETER	TEST CONDITIONS		MIN	TYP	MAX ⁽¹⁾	UNIT
Accuracy ⁽²⁾	$V_{DD} = 2.7\text{ V}$ to $V_{DD} = 4.5\text{ V}$	$T_A = -10^\circ\text{C}$ to 80°C	$T_A = T_J = T_{MIN}$ to T_{MAX}		± 1	$^\circ\text{C}$
		$T_A = -25^\circ\text{C}$ to 115°C	$T_A = T_J = T_{MIN}$ to T_{MAX}		± 1.5	$^\circ\text{C}$
		$T_A = -40^\circ\text{C}$ to 150°C	$T_A = T_J = T_{MIN}$ to T_{MAX}		± 2	$^\circ\text{C}$
	$V_{DD} > 4.5\text{ V}$ to $V_{DD} = 5.5\text{ V}$	$T_A = -10^\circ\text{C}$ to 80°C	$T_A = T_J = T_{MIN}$ to T_{MAX}		± 1.5	$^\circ\text{C}$
		$T_A = -25^\circ\text{C}$ to 115°C	$T_A = T_J = T_{MIN}$ to T_{MAX}		± 2	$^\circ\text{C}$
		$T_A = -40^\circ\text{C}$ to 150°C	$T_A = T_J = T_{MIN}$ to T_{MAX}		± 2.5	$^\circ\text{C}$
Resolution	RES1 Bit = 0, RES0 Bit = 0				11	Bits
					0.25	$^\circ\text{C}/\text{LSB}$
	RES1 Bit = 0, RES0 Bit = 1				12	Bits
					0.125	$^\circ\text{C}/\text{LSB}$
	RES1 Bit = 1, RES0 Bit = 0				13	Bits
					0.0625	$^\circ\text{C}/\text{LSB}$
RES1 Bit = 1, RES0 Bit = 1				14	Bits	
				0.03125	$^\circ\text{C}/\text{LSB}$	
Temperature Conversion Time ⁽³⁾	RES1 Bit = 0, RES0 Bit = 0				10.1	ms
			$T_A = T_J = T_{MIN}$ to T_{MAX}		14	
	RES1 Bit = 0, RES0 Bit = 1				20.2	ms
			$T_A = T_J = T_{MIN}$ to T_{MAX}		28	
	RES1 Bit = 1, RES0 Bit = 0				40.4	ms
			$T_A = T_J = T_{MIN}$ to T_{MAX}		56	
	RES1 Bit = 1, RES0 Bit = 1				80.8	ms
			$T_A = T_J = T_{MIN}$ to T_{MAX}		112	
Quiescent Current	Continuous Conversion Mode, SMBus inactive				320	μA
			$T_A = T_J = T_{MIN}$ to T_{MAX}		495	
	Shutdown, bus-idle timers on				120	μA
			$T_A = T_J = T_{MIN}$ to T_{MAX}		175	
	Shutdown, bus-idle timers off				1.9	μA
			$T_A = T_J = T_{MIN}$ to T_{MAX}		8	
Power-On Reset Threshold	Measured on V_{DD} input, falling edge		$T_A = T_J = T_{MIN}$ to T_{MAX}		0.9	V

(1) Limits are specified to AOQL (Average Outgoing Quality Level).

(2) Local temperature accuracy does not include the effects of self-heating. The rise in temperature due to self-heating is the product of the internal power dissipation of the LM73 and the thermal resistance.

(3) This specification is provided only to indicate how often temperature data is updated. The LM73 can be read at any time without regard to conversion state (and will yield last conversion result).

6.6 Logic Electrical Characteristics- Digital DC Characteristics

Unless otherwise noted, these specifications apply for $V_{DD} = 2.7\text{ V}$ to 5.5 V . All limits $T_A = T_J = 25^\circ\text{C}$, unless otherwise noted. T_A is the ambient temperature. T_J is the junction temperature.

PARAMETER		TEST CONDITIONS		MIN	TYP ⁽¹⁾	MAX ⁽²⁾	UNIT
SMBDAT, SMBCLK INPUTS							
V_{IH}	Logical 1 Input Voltage	$T_A = T_J = T_{MIN}$ to T_{MAX}		$0.7 \times V_{DD}$			V
V_{IL}	Logical 0 Input Voltage	$T_A = T_J = T_{MIN}$ to T_{MAX}		$0.3 \times V_{DD}$			V
$V_{IN;HYST}$	SMBDAT and SMBCLK Digital Input Hysteresis			$0.07 \times V_{DD}$			V
I_{IH}	Logical 1 Input Current	$V_{IN} = V_{DD}$		0.01			μA
			$T_A = T_J = T_{MIN}$ to T_{MAX}	2			
I_{IL}	Logical 0 Input Current	$V_{IN} = 0\text{ V}$		-0.01			μA
			$T_A = T_J = T_{MIN}$ to T_{MAX}	-2			
C_{IN}	Input Capacitance			5			pF
SMBDAT, ALERT OUTPUTS							
I_{OH}	High Level Output Current	$V_{OH} = V_{DD}$		0.01			μA
			$T_A = T_J = T_{MIN}$ to T_{MAX}	2			
V_{OL}	SMBus Low Level Output Voltage	$I_{OL} = 3\text{ mA}$	$T_A = T_J = T_{MIN}$ to T_{MAX}	0.4			V
ADDRESS INPUT							
$V_{IH;ADDR}$	Address Pin High Input Voltage	$T_A = T_J = T_{MIN}$ to T_{MAX}		$V_{DD} - 0.100$			V
$V_{IL;ADDR}$	Address Pin Low Input Voltage	$T_A = T_J = T_{MIN}$ to T_{MAX}		0.100			V
$I_{IH;ADDRESS}$	Address Pin High Input Current	$V_{IN} = V_{DD}$		0.01			μA
			$T_A = T_J = T_{MIN}$ to T_{MAX}	2			
$I_{IL;ADDR}$	Address Pin Low Input Current	$V_{IN} = 0\text{ V}$		-0.01			μA
			$T_A = T_J = T_{MIN}$ to T_{MAX}	-2			

(1) Typicals are at $T_A = 25^\circ\text{C}$ and represent most likely parametric norm.

(2) Limits are specified to AOQL (Average Outgoing Quality Level).

6.7 Logic Electrical Characteristics- SMBus Digital Switching Characteristics

Unless otherwise noted, these specifications apply for $V_{DD} = 2.7\text{ V}$ to 5.5 V , C_L (load capacitance) on output lines = 400 pF . All limits $T_A = T_J = 25^\circ\text{C}$, unless otherwise noted. See [Figure 1](#).

PARAMETER		TEST CONDITIONS		MIN	TYP ⁽¹⁾	MAX ⁽²⁾	UNIT
f_{SMB}	SMBus Clock Frequency	No minimum clock frequency if Time-Out feature is disabled.	$T_A = T_J = T_{MIN}$ to T_{MAX}			400	kHz
t_{LOW}	SMBus Clock Low Time	$T_A = T_J = T_{MIN}$ to T_{MAX}		300			ns
t_{HIGH}	SMBus Clock High Time	$T_A = T_J = T_{MIN}$ to T_{MAX}		300			ns
$t_{F,SMB}$ t_{O}	Output Fall Time ⁽³⁾	$C_L = 400\text{ pF}$ $I_{PULL-UP} \leq 3\text{ mA}$	$T_A = T_J = T_{MIN}$ to T_{MAX}			250	ns
t_{TIMEO} t_{UT}	SMBDAT and SMBCLK Time Low for Reset of Serial Interface ⁽⁴⁾	$T_A = T_J = T_{MIN}$ to T_{MAX}		15		45	ms
$t_{SU,DA}$ t_{TI}	Data In Setup Time to SMBCLK High	$T_A = T_J = T_{MIN}$ to T_{MAX}		100			ns
$t_{HD,DA}$ t_{TI}	Data Hold Time: Data In Stable after SMBCLK Low	$T_A = T_J = T_{MIN}$ to T_{MAX}		0			ns
$t_{HD,DA}$ t_{TO}	Data Hold Time: Data Out Stable after SMBCLK Low	$T_A = T_J = T_{MIN}$ to T_{MAX}		30			ns
$t_{HD,STA}$	Start Condition SMBDAT Low to SMBCLK Low (Start condition hold before the first clock falling edge)	$T_A = T_J = T_{MIN}$ to T_{MAX}		60			ns
$t_{SU,ST}$ t_{O}	Stop Condition SMBCLK High to SMBDAT Low (Stop Condition Setup)	$T_A = T_J = T_{MIN}$ to T_{MAX}		50			ns
$t_{SU,STA}$	SMBus Repeated Start-Condition Setup Time, SMBCLK High to SMBDAT Low	$T_A = T_J = T_{MIN}$ to T_{MAX}		50			ns
t_{BUF}	SMBus Free Time Between Stop and Start Conditions	$T_A = T_J = T_{MIN}$ to T_{MAX}		1.2			μs
t_{POR}	Power-On Reset Time ⁽⁵⁾	$T_A = T_J = T_{MIN}$ to T_{MAX}				1	ms

(1) Typicals are at $T_A = 25^\circ\text{C}$ and represent most likely parametric norm.

(2) Limits are specified to AOQL (Average Outgoing Quality Level).

(3) The output fall time is measured from $(V_{IH,MIN} + 0.15\text{V})$ to $(V_{IL,MAX} - 0.15\text{V})$.

(4) Holding the SMBDAT and/or SMBCLK lines Low for a time interval greater than $t_{TIMEOUT}$ will reset the LM73's SMBus state machine, setting SMBDAT and SMBCLK pins to a high impedance state.

(5) Represents the time from V_{DD} reaching the power-on-reset level to the LM73 communications being functional. After an additional time equal to one temperature conversion time, valid temperature is available in the [Temperature Data Register](#).

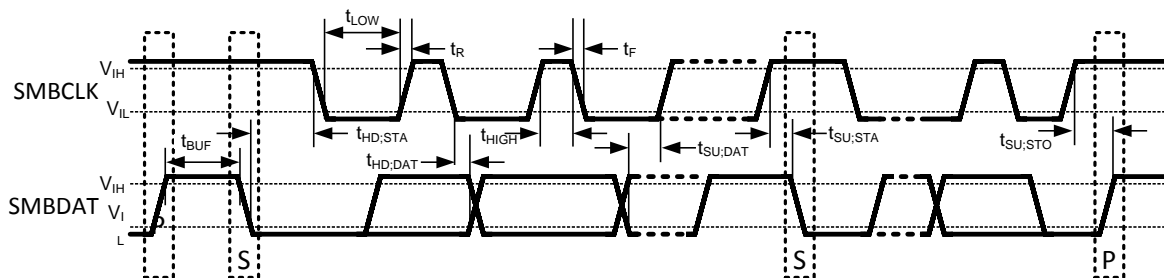

Figure 1. SMBus Communication

6.8 Typical Characteristics

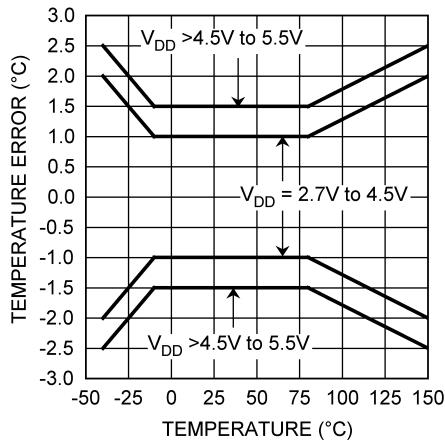

Figure 2. Accuracy vs. Temperature

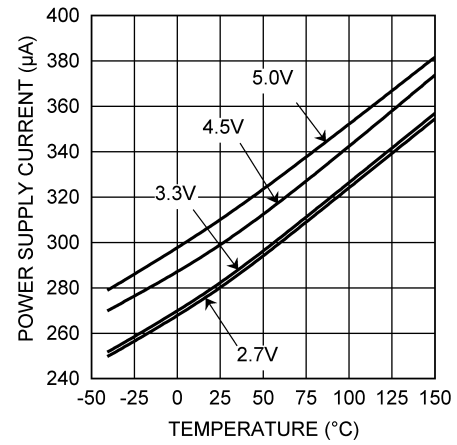

Figure 3. Operating Current vs. Temperature

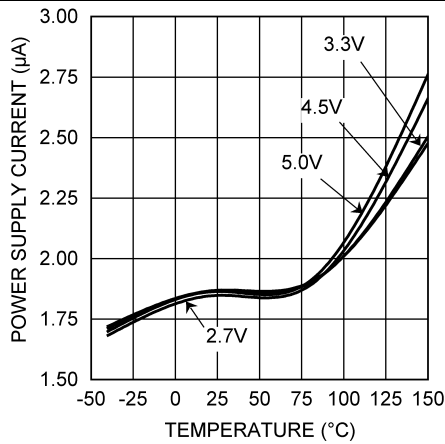

Figure 4. Shutdown Current vs. Temperature

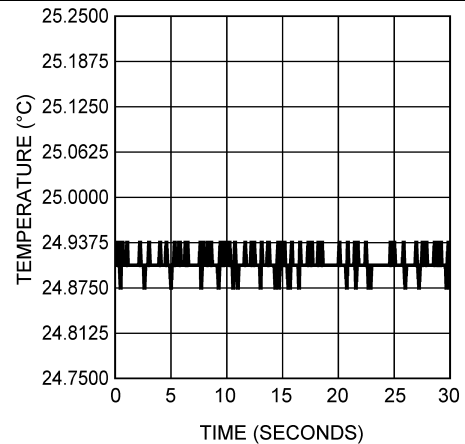

Figure 5. Typical Output Noise

7 Detailed Description

7.1 Overview

The LM73 is a digital temperature sensor that senses the temperature of its die using a sigma-delta analog-to-digital converter and stores the temperature in the Temperature Register. The LM73's 2-wire serial interface is compatible with SMBus 2.0 and I²C. Please see the SMBus 2.0 specification for a detailed description of the differences between the I²C bus and SMBus.

The temperature resolution is programmable, allowing the host system to select the optimal configuration between sensitivity and conversion time. The LM73 can be placed in shutdown to minimize power consumption when temperature data is not required. While in shutdown, a 1-shot conversion mode allows system control of the conversion rate for ultimate flexibility.

7.2 Functional Block Diagram

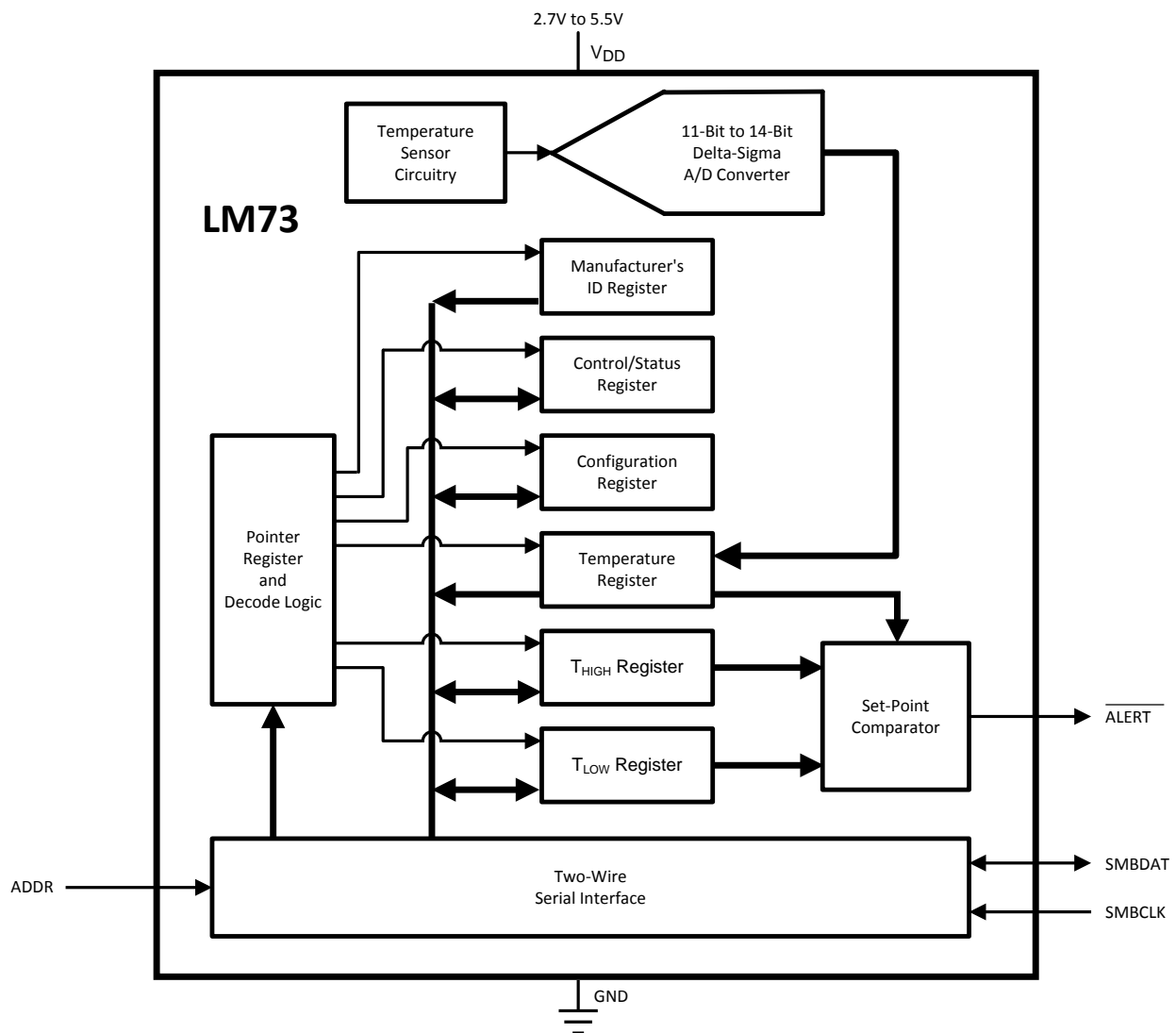

7.3 Feature Description

The LM73 features the following registers. See [LM73 Registers](#) for a complete list of the pointer address, content, and reset state of each register.

- Pointer Register

Feature Description (continued)

- Temperature Register
- Configuration Register
- T_{HIGH} Register
- T_{LOW} Register
- Control/Status Register
- Identification Register

7.3.1 Power-On Reset

The power-on reset (POR) state is the point at which the supply voltage rises above the power-on reset threshold (specified in the [Electrical Characteristics](#)), generating an internal reset. Each of the registers contains a defined value upon POR and this data remains there until any of the following occurs:

- The first temperature conversion is completed, causing the Temperature Register and various status bits to be updated internally, depending on the value of the measured temperature.
- The master writes different data to any Read/Write (R/W) bits, or
- The LM73 is powered down.

7.3.2 One-Shot Conversion

The LM73 features a one-shot conversion bit, which is used to initiate a single conversion and comparison cycle when the LM73 is in shutdown mode. While the LM73 is in shutdown mode, writing a 1 to the One-Shot bit in the Configuration Register will cause the LM73 to perform a single temperature conversion and update the Temperature Register and the affected status bits. Operating the LM73 in this one-shot mode allows for extremely low average-power consumption, making it ideal for low-power applications.

When the One-Shot bit is set, the LM73 initiates a temperature conversion. After this initiation, but before the completion of the conversion and resultant register updates, the LM73 is in a "one-shot" state. During this state, the Data Available (DAV) flag in the Control/Status register is 0 and the Temperature Register contains the value 8000h (-256°C). All other registers contain the data that was present before initiating the one-shot conversion. After the temperature measurement is complete, the DAV flag will be set to 1 and the temperature register will contain the resultant measured temperature.

7.3.3 Temperature Data Format

The resolution of the temperature data and the size of the data word are user-selectable through bits RES1 and RES0 in the [Control/Status Register](#). By default, the LM73 temperature stores the measured temperature in an 11-bit (10 bits plus sign) word with one least significant bit (LSB) equal to 0.25°C. The maximum word size is 14 bits (13-bits plus sign) with a resolution of 0.03125 °C/LSB.

CONTROL BIT		DATA FORMAT	
RES1	RES0	WORD SIZE	RESOLUTION
0	0	11 bits	0.25 °C/LSB
0	1	12 bits	0.125 °C/LSB
1	0	13 bits	0.0625 °C/LSB
1	1	14 bits	0.03125 °C/LSB

The temperature data is reported in 2's complement format. The word is stored in the 16-bit Temperature Register and is left justified in this register. Unused temperature-data bits are always reported as 0.

Table 1. 11-Bit (10-Bit Plus Sign)

TEMPERATURE	DIGITAL OUTPUT	
	BINARY	HEX
150°C	0100 1011 0000 0000	4B00h
25°C	0000 1100 1000 0000	0C80h
1°C	0000 0000 1000 0000	0080h
0.25°C	0000 0000 0010 0000	0020h

Table 1. 11-Bit (10-Bit Plus Sign) (continued)

TEMPERATURE	DIGITAL OUTPUT	
	BINARY	HEX
0°C	0000 0000 0000 0000	0000h
-0.25°C	1111 1111 1110 0000	FFE0h
-1°C	1111 1111 1000 0000	FF80h
-25°C	1111 0011 1000 0000	F380h
-40°C	1110 1100 0000 0000	EC00h

Table 2. 12-Bit (11-Bit Plus Sign)

TEMPERATURE	DIGITAL OUTPUT	
	BINARY	HEX
150°C	0100 1011 0000 0000	4B00h
25°C	0000 1100 1000 0000	0C80h
1°C	0000 0000 1000 0000	0080h
0.125°C	0000 0000 0001 0000	0010h
0°C	0000 0000 0000 0000	0000h
-0.125°C	1111 1111 1111 0000	FFF0h
-1°C	1111 1111 1000 0000	FF80h
-25°C	1111 0011 1000 0000	F380h
-40°C	1110 1100 0000 0000	EC00h

Table 3. 13-Bit (12-Bit Plus Sign)

TEMPERATURE	DIGITAL OUTPUT	
	BINARY	HEX
150°C	0100 1011 0000 0000	4B00h
25°C	0000 1100 1000 0000	0C80h
1°C	0000 0000 1000 0000	0080h
0.0625°C	0000 0000 0000 1000	0008h
0°C	0000 0000 0000 0000	0000h
-0.0625°C	1111 1111 1111 1000	FFF8h
-1°C	1111 1111 1000 0000	FF80h
-25°C	1111 0011 1000 0000	F380h
-40°C	1110 1100 0000 0000	EC00h

Table 4. 14-Bit (13-Bit Plus Sign)

TEMPERATURE	DIGITAL OUTPUT	
	BINARY	HEX
150°C	0100 1011 0000 0000	4B00h
25°C	0000 1100 1000 0000	0C80h
1°C	0000 0000 1000 0000	0080h
0.03125°C	0000 0000 0000 0100	0004h
0°C	0000 0000 0000 0000	0000h
-0.03125°C	1111 1111 1111 1100	FFFC h
-1°C	1111 1111 1000 0000	FF80h
-25°C	1111 0011 1000 0000	F380h
-40°C	1110 1100 0000 0000	EC00h

7.3.4 SMBus Interface

The LM73 operates as a slave on the SMBus. The SMBDAT line is bidirectional. The SMBCLK line is an input only. The LM73 never drives the SMBCLK line and it does not support clock stretching.

The LM73 uses a 7-bit slave address. It is available in two versions. Each version can be configured for one of three unique slave addresses, for a total of six unique address.

PART NUMBER	ADDRESS PIN	DEVICE ADDRESS
LM73-0	Float	1001 000
	Ground	1001 001
	V _{DD}	1001 010
LM73-1	Float	1001 100
	Ground	1001 101
	V _{DD}	1001 110

The SMBDAT output is an open-drain output and does not have internal pull-ups. A “high” level will not be observed on this pin until pull-up current is provided by some external source, typically a pull-up resistor. Choice of resistor value depends on many system factors but, in general, the pull-up resistor should be as large as possible without effecting the SMBus desired data rate. This will minimize any internal temperature reading errors due to internal heating of the LM73.

The LM73 features an integrated low-pass filter on both the SMBCLK and the SMBDAT line. These filters increase communications reliability in noisy environments.

If either the SMBCLK or SMBDAT line is held low for a time greater than t_{TIMEOUT} (see [Logic Electrical Characteristics](#) for the value of t_{TIMEOUT}), the LM73 state machine will reset to the SMBus idle state, releasing the data line. Once the SMBDAT is released high, the master may initiate an SMBus start.

7.3.5 ALERT Function

The $\overline{\text{ALERT}}$ output is an over-temperature indicator. At the end of every temperature conversion, the measured temperature is compared to the value in the T_{HIGH} Register. If the measured temperature exceeds the value stored in T_{HIGH}, the $\overline{\text{ALERT}}$ output goes active (see [Figure 6](#)). This over-temperature condition will also cause the ALRT_STAT bit in the Control/Status Register to change value (this bit mirrors the logic level of the $\overline{\text{ALERT}}$ pin).

The $\overline{\text{ALERT}}$ pin and the ALRT_STAT bit are cleared when any of the following occur:

- The measured temperature falls below the value stored in the T_{LOW} Register
- A 1 is written to the $\overline{\text{ALERT}}$ Reset bit in the Configuration Register
- The master resets it through an SMBus Alert Response Address (ARA) procedure

If $\overline{\text{ALERT}}$ has been cleared by the master writing a 1 to the $\overline{\text{ALERT}}$ Reset bit, while the measured temperature still exceeds the T_{HIGH} setpoint, $\overline{\text{ALERT}}$ will go active again after the completion of the next temperature conversion.

Each temperature reading is associated with a Temperature High (THI) and a Temperature Low (TLOW) flag in the Control/Status Register. A digital comparison determines whether that reading is above the T_{HIGH} setpoint or below the T_{LOW} setpoint. If so, the corresponding flag is set. All digital comparisons to the T_{HIGH}, and T_{LOW} values are based on an 11-bit temperature comparison. Regardless of the resolution setting of the LM73, the lower three temperature LSBs will not affect the state of the $\overline{\text{ALERT}}$ output, THI flag, and TLOW flag.

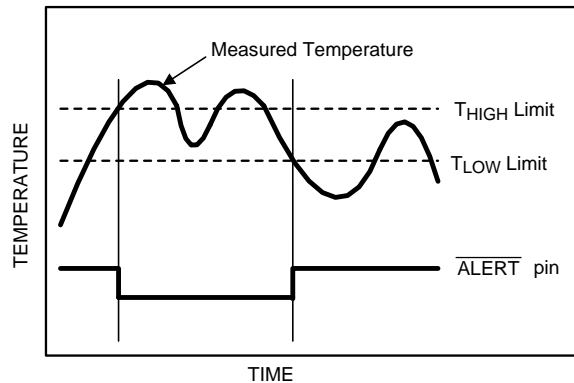

Figure 6. $\overline{\text{ALERT}}$ Temperature Response Cleared When Temperature Crosses T_{LOW}

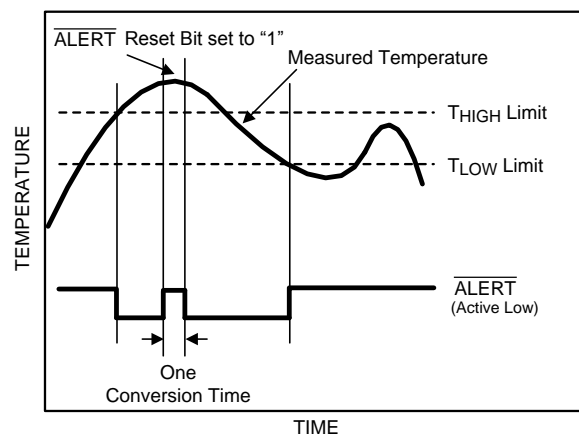

Figure 7. $\overline{\text{ALERT}}$ Temperature Response Cleared by Writing a 1 to the $\overline{\text{ALERT}}$ Reset Bit.

7.3.6 Communicating With the LM73

The data registers in the LM73 are selected by the Pointer Register. At power-up the Pointer Register is set to 00h, the location for the Temperature Register. The Pointer Register latches the last location it was set to. Note that all Pointer Register bits are decoded; any incorrect pointer values will not be acknowledged and will not be stored in the Pointer Register.

NOTE

A write to an invalid pointer address is not allowed. If the master writes an invalid address to the Pointer Register, the LM73 will not acknowledge the address and the Pointer Register will continue to contain the last value stored in it.

A **Write** to the LM73 will always include the address byte and the pointer byte.

A **Read** from the LM73 can occur in either of the following ways:

- If the location latched in the Pointer Register is correct (that is, the Pointer Register is pre-set prior to the read), then the read can simply consist of an address byte, followed by retrieving the data byte. Most of the time it is expected that the Pointer Register will point to Temperature Registers because that will be the data most frequently read from the LM73.
- If the Pointer Register needs to be set, then an address byte, pointer byte, repeat start, and another address byte will accomplish a read.

The data byte is read out of the LM73 by the most significant bit first. At the end of a read, the LM73 can accept either an Acknowledge or No Acknowledge bit from the Master. No Acknowledge is typically used as a signal to the slave that the Master has read its last byte.

7.3.6.1 Reading from the LM73

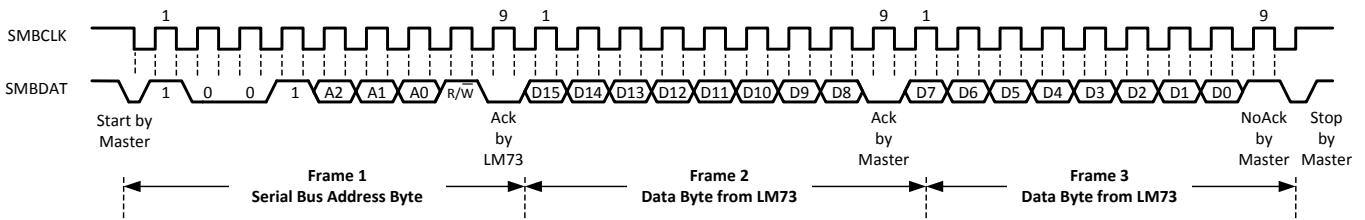

Figure 8. Typical Read from a 2-Byte Register with Preset Pointer

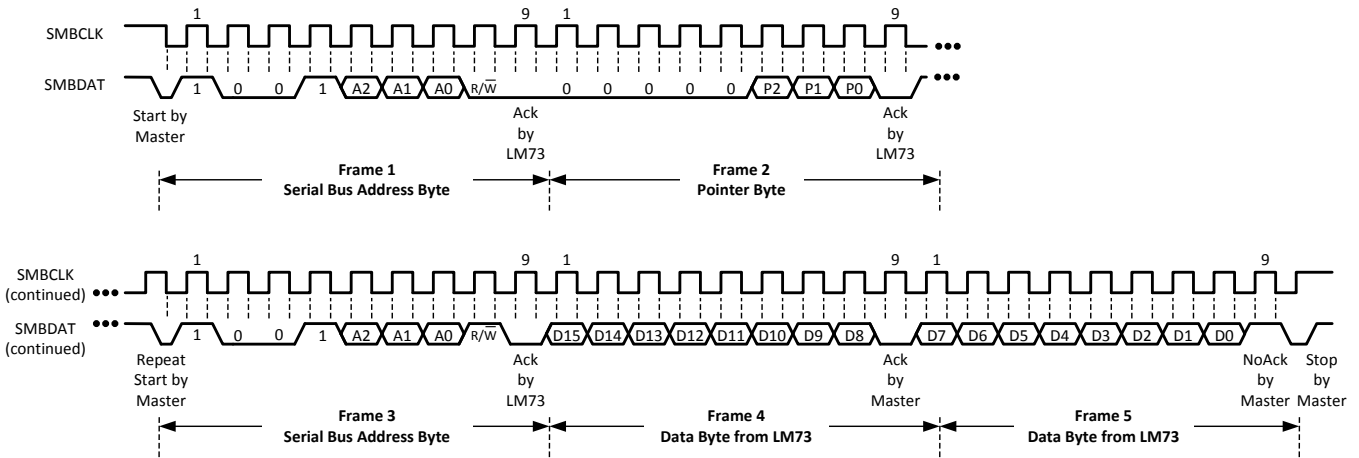

Figure 9. Typical Pointer Set Followed by Immediate Read of a 2-Byte Register

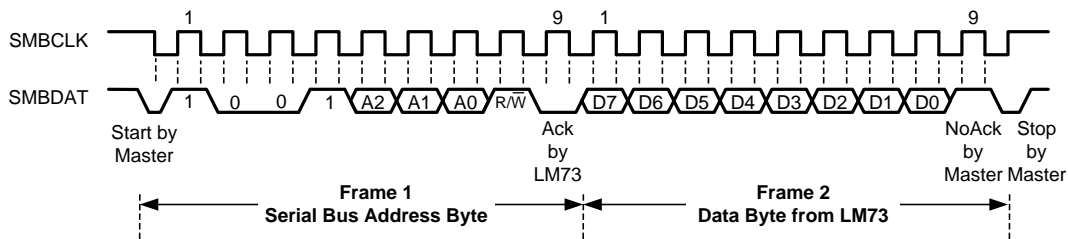

Figure 10. Typical Read from a 1-Byte Register with Preset Pointer

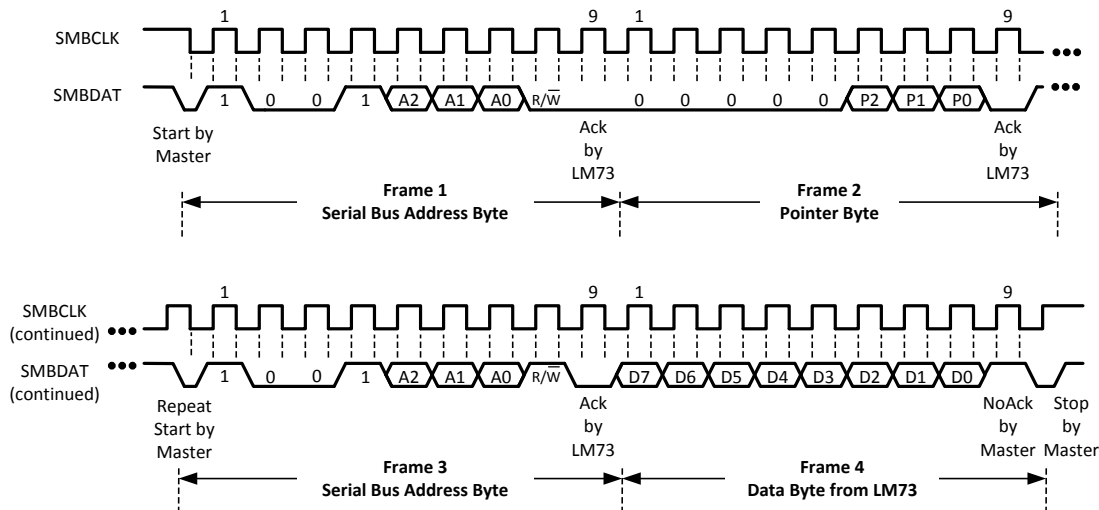

Figure 11. Typical Pointer Set Followed by Immediate Read of a 1-Byte Register

7.3.6.2 Writing to the LM73

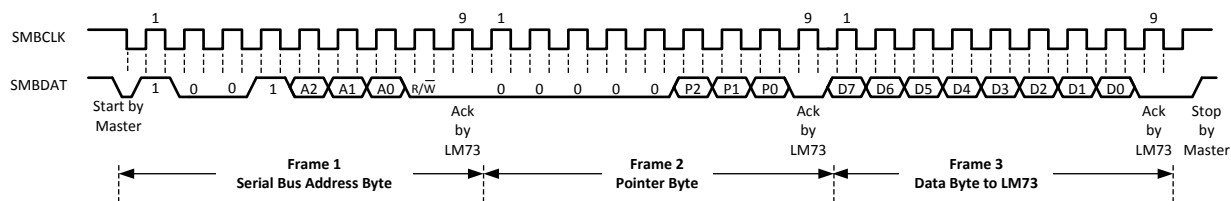

Figure 12. Typical 1-Byte Write

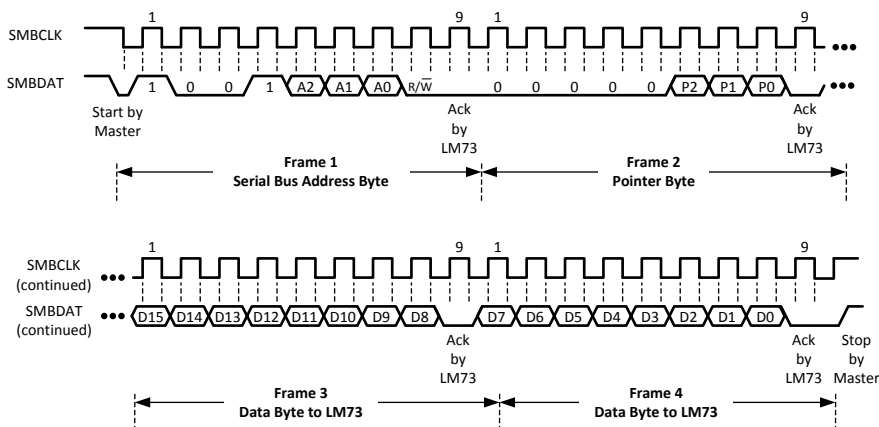

Figure 13. Typical 2-Byte Write

7.4 Device Functional Modes

7.4.1 Shutdown Mode

Shutdown Mode is enabled by writing a “1” to the Full Power Down Bit, Bit 7 of the Configuration Register, and holding it high for at least the specified maximum conversion time at the existing temperature resolution setting. (see Temperature Conversion Time specifications under the *Temperature-to-Digital Converter Characteristics*). For example, if the LM73 is set for 12-bit resolution before shutdown, then Bit 7 of the Configuration register must go high and stay high for the specified maximum conversion time for 12-bits resolution.

Device Functional Modes (continued)

The LM73 will always finish a temperature conversion and update the temperature registers before shutting down.

Writing a “0” to the Full Power Down Bit restores the LM73 to normal mode. The user should wait at least the specified maximum conversion time, at the existing resolution setting, before accurate data appears in the temperature register.

7.5 Register Map

7.5.1 LM73 Registers

The LM73's internal registers are selected by the Pointer register. The Pointer register latches the last location that it was set to. The pointer register and all internal registers are described below. All registers reset at device power up.

7.5.1.1 Pointer Register

The diagram below shows the Pointer Register, the six internal registers to which it points, and their associated pointer addresses.

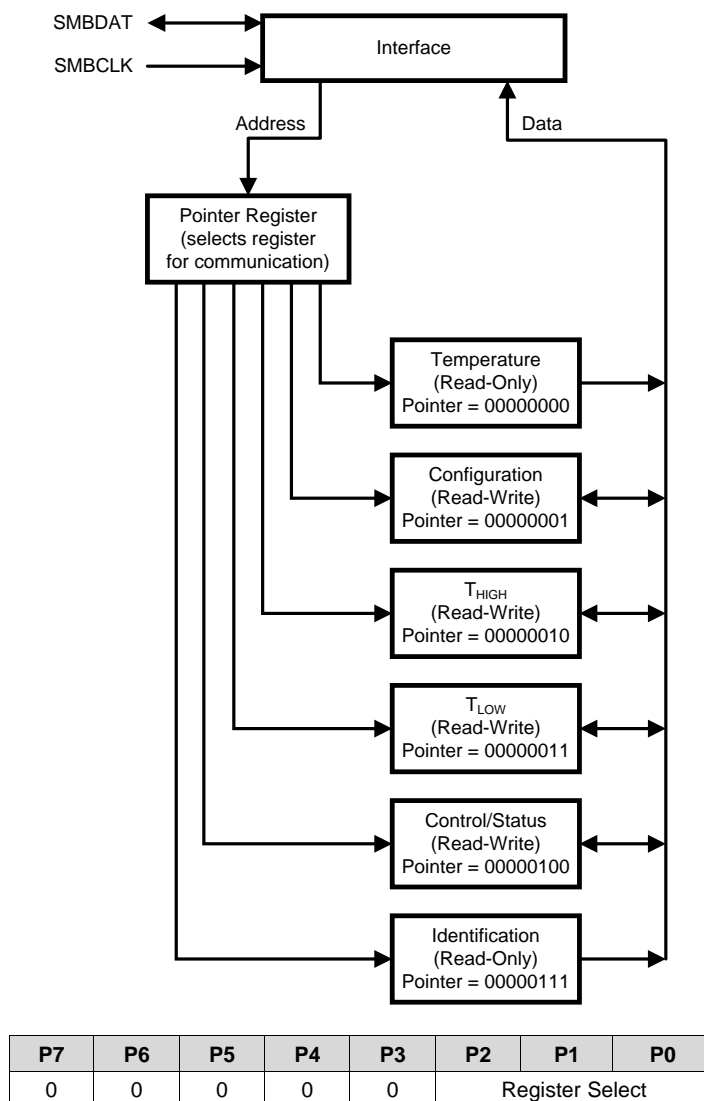

Bits	Name	Description
7:3	Not Used	Must write zeros only.
2:0	Register Select	Pointer address. Points to desired register. See table below.

P2	P1	P0	REGISTER ⁽¹⁾
0	0	0	Temperature
0	0	1	Configuration
0	1	0	T _{HIGH}
0	1	1	T _{LOW}
1	0	0	Control / Status
1	1	1	Identification

- (1) A write to an invalid pointer address is not allowed. If the master writes an invalid address to the Pointer Register,
- (a) the LM73 will not acknowledge the address and
 - (b) the Pointer Register will continue to contain the last value stored in it.

7.5.1.2 Temperature Data Register

Pointer Address 00h (Read Only)

Reset State: 7FFCh (+255.96875°C)

One-Shot State: 8000h (-256°C)

D15	D14	D13	D12	D11	D10	D9	D8
SIGN	128°C	64°C	32°C	16°C	8°C	4°C	2°C

D7	D6	D5	D4	D3	D2	D1	D0
1°C	0.5°C	0.25°C	0.125°C	0.0625°C	0.03125°C	reserved	reserved

Bits	Name	Description
15:2	Temperature Data	Represents the temperature that was measured by the most recent temperature conversion. On Power-up, this data is invalid until the Data Available (DAV) bit in the Control/Status register is high (after the completion of the first temperature conversion). The resolution is user-programmable from 11-bit resolution (0.25°C/LSB) through 14-bit resolution (0.03125°C/LSB). The desired resolution is programmed with bits 5 and 6 of the Control/Status register.
1:0	Not Used	Return zeros upon read.

LM73

SNIS141F –OCTOBER 2005–REVISED OCTOBER 2015

www.ti.com
7.5.1.3 Configuration Register

Pointer Address 01h (R/W)

Reset State: 40h

D7	D6	D5	D4	D3	D2	D1	D0
PD	reserved	ALRT EN	ALRT POL	ALRT RST	ONE SHOT	reserved	

Bits	Name	Description
7	Full Power Down	Writing a 1 to this bit and holding it high for at least the specified maximum conversion time, at the existing temperature resolution setting, puts the LM73 in shutdown mode for power conservation. Writing a 0 to this bit restores the LM73 to normal mode. Waiting one specified maximum conversion time for the existing resolution setting assures accurate data in the temperature register.
6	reserved	User must write only a 1 to this bit
5	ALERT Enable	A 0 in this location enables the $\overline{\text{ALERT}}$ output. A 1 disables it. This bit also controls the $\overline{\text{ALERT}}$ Status bit (the Control/Status Register, Bit 3) since that bit reflects the state of the Alert pin.
4	ALERT Polarity	When set to 1, the $\overline{\text{ALERT}}$ pin and $\overline{\text{ALERT}}$ Status bit are active-high. When 0, it is active-low.
3	ALERT Reset	Writing a 1 to this bit resets the $\overline{\text{ALERT}}$ pin and the $\overline{\text{ALERT}}$ Status bit. It will always be 0 when read.
2	One Shot	When in shutdown mode (Bit 7 is 1), initiates a single temperature conversion and update of the temperature register with new temperature data. Has no effect when in continuous conversion mode (i.e., when Bit 7 is 0). Always returns a 0 when read.
1:0	Reserved	User must write only a 0 to these bits.

7.5.1.4 T_{HIGH} Upper-Limit Register

Pointer Address 02h (R/W)

Reset State: 7FE0h (+255.75°C)

D15	D14	D13	D12	D11	D10	D9	D8
SIGN	128°C	64°C	32°C	16°C	8°C	4°C	2°C

D7	D6	D5	D4	D3	D2	D1	D0
1°C	0.5°C	0.25°C	reserved				

Bits	Name	Description
15:5	Upper-Limit Temperature	If the measured temperature that is stored in this register exceeds this user-programmable upper temperature limit, the $\overline{\text{ALERT}}$ pin will go active and the THIGH flag in the Control/Status register will be set to 1. Two's complement format.
4:0	Reserved	Returns zeros upon read. Recommend writing zeros only in these bits.

7.5.1.5 T_{LOW} Lower-Limit Register

Pointer Address 03h (R/W)

Reset State: 8000h (–256°C)

D15	D14	D13	D12	D11	D10	D9	D8
SIGN	128°C	64°C	32°C	16°C	8°C	4°C	2°C

D7	D6	D5	D4	D3	D2	D1	D0
1°C	0.5°C	0.25°C	reserved				

Bits	Name	Description
15:5	Lower-Limit Temperature	If the measured temperature that is stored in the temperature register falls below this user-programmable lower temperature limit, the $\overline{\text{ALERT}}$ pin will be deactivated and the T_{LOW} flag in the Control/Status register will be set to 1. Two's complement format.
4:0	Reserved	Returns zeros upon read. Recommend writing zeros only in these bits.

7.5.1.6 Control/Status Register

Pointer Address 04h (R/W)

Reset State: 08h

D7	D6	D5	D4	D3	D2	D1	D0
TO_DIS	RES1	RES0	reserved	ALRT_STAT	THI	TLOW	DAV

BITS	NAME	DESCRIPTION
7	Time-Out Disable	Disable the time-out feature on the SMBDAT and SMBCLK lines if set to 1. Setting this bit turns off the bus-idle timers, enabling the LM73 to operate at lowest shutdown current.
6:5	Temperature Resolution	Selects one of four user-programmable temperature data resolutions 00: 0.25°C/LSB, 11-bit word (10 bits plus Sign) 01: 0.125°C/LSB, 12-bit word (11 bits plus Sign) 10: 0.0625°C/LSB, 13-bit word (12 bits plus Sign) 11: 0.03125°C/LSB, 14-bit word (13 bits plus Sign)
4	reserved	Always returns zero when read. Recommend customer write zero only.
3	ALERT Pin Status	Value is 0 when $\overline{\text{ALERT}}$ output pin is low. Value is 1 when $\overline{\text{ALERT}}$ output pin is high. The $\overline{\text{ALERT}}$ output pin is reset under any of the following conditions: (1) Cleared by writing a 1 to the ALERT Reset bit in the configuration register, (2) Measured temperature falls below the T_{LOW} limit, or (3) cleared via the ARA sequence. Recommend customer write zero only.
2	Temperature High Flag	Bit is set to 1 when the measured temperature exceeds the T_{HIGH} limit stored in the programmable T_{HIGH} register. Flag is reset to 0 when both of the following conditions are met: (1) measured temperature no longer exceeds the programmed T_{HIGH} limit <i>and</i> (2) upon reading the Control/Status register. If the temperature is not longer above the T_{HIGH} limit, this status bit remains set until it is read by the master so that the system can check the history of what caused the ALERT output to go active. This bit is not cleared after every read if the measured temperature is still above the T_{HIGH} limit.
1	Temperature Low Flag	Bit is set to 1 when the measured temperature falls below the T_{LOW} limit stored in the programmable T_{LOW} register. Flag is reset to 0 when both of the following conditions are met: (1) measured temperature is no longer below the programmed T_{LOW} limit <i>and</i> (2) upon reading the Control/Status register. If the temperature is no longer below the T_{LOW} limit, the status bit remains set until it is read by the master so that the system can check the history of what caused the ALERT output to go active. This bit is not cleared after every read if temperature is still below T_{LOW} limit.
0	Data Available Flag	This bit is 0 when the LM73 is in the process of converting a new temperature. It is 1 when the conversion is done. After initiating a temperature conversion while operating in the one-shot mode, this status bit can be monitored to indicate when the conversion is done. After triggering the one-shot conversion, the data in the temperature register is invalid until this bit is high (that is, after completion of the conversion). On power-up, the LM73 is in continuous conversion mode; while in continuous conversion mode (the default mode after power-on reset) this bit will always be high. Recommend customer write zero only.

7.5.1.7 Identification Register

Pointer Address 07h (Read Only)

Reset State: 0190h

D15	D14	D13	D12	D11	D10	D9	D8
0	0	0	0	0	0	0	1

D7	D6	D5	D4	D3	D2	D1	D0
1	0	0	1	0	0	0	0

BITS	NAME	DESCRIPTION
15:8	Manufacturer Identification Byte	Always returns 01h to uniquely identify the manufacturer as Texas Instruments.
7:4	Product Identification Nibble	Always returns 9h to uniquely identify this part as the LM73 Temperature Sensor.
3:0	Die Revision Step Nibble	Always returns 0h to uniquely identify the revision as level zero.

8 Application and Implementation

NOTE

Information in the following applications sections is not part of the TI component specification, and TI does not warrant its accuracy or completeness. TI's customers are responsible for determining suitability of components for their purposes. Customers should validate and test their design implementation to confirm system functionality.

8.1 Application Information

8.1.1 Thermal Path Considerations

To get the expected results when measuring temperature with an integrated circuit temperature sensor like the LM73, it is important to understand that the sensor measures its own die temperature. For the LM73, the best thermal path between the die and the outside world is through the LM73's pins. In the SOT23 package, all the pins on the LM73 will have an equal effect on the die temperature. Because the pins represent a good thermal path to the LM73 die, the LM73 will provide an accurate measurement of the temperature of the printed circuit board on which it is mounted. There is a less efficient thermal path between the plastic package and the LM73 die. If the ambient air temperature is significantly different from the printed circuit board temperature, it will have a small effect on the measured temperature.

8.1.2 Output Considerations: Tight Accuracy, Resolution and Low Noise

The LM73 is well suited for applications that require tight temperature measurement accuracy. In many applications, the low temperature error can mean better system performance and, by eliminating a system calibration step, lower production cost.

With digital resolution as fine as 0.03125 °C/LSB, the LM73 senses and reports very small changes in its temperature, making it ideal for applications where temperature sensitivity is important. For example, the LM73 enables the system to quickly identify the direction of temperature change, allowing the processor to take compensating action before the system reaches a critical temperature.

The LM73 has very low output noise, typically 0.015°C rms, which makes it ideal for applications where stable thermal compensation is a priority. For example, in a temperature-compensated oscillator application, the very small deviation in successive temperature readings translates to a stable frequency output from the oscillator.

8.2 Typical Application

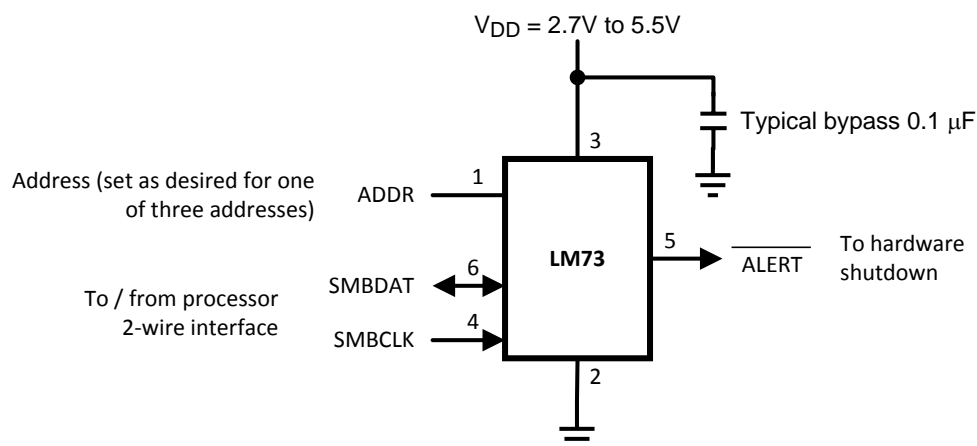

Figure 14. Digital Temperature Sensing

8.2.1 Design Requirements

The LM73 requires positive supply voltage of 2.7 V to 5.5 V to be applied between +V_{DD} and GND. For best results, bypass capacitors of 100 nF and 10 μF are recommended.

Typical Application (continued)

8.2.2 Detailed Design Procedure

The temperature resolution is programmable, allowing the host system to select the optimal configuration between sensitivity and conversion time. The LM73 can be placed in shutdown to minimize power consumption when temperature data is not required. While in shutdown, a 1-shot conversion mode allows system control of the conversion rate for ultimate flexibility.

8.2.3 Application Curve

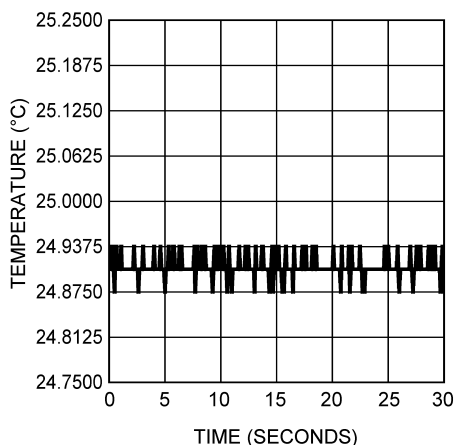

Figure 15. Typical Performance

9 Power Supply Recommendations

In systems where there is a large amount of capacitance on the V_{DD} node, the LM73 power supply ramp-up time can become excessively long. Slow power-supply ramp times may result in abnormal temperature readings. A linear power-on-ramp of less than 0.7 V/msec and an exponential ramp with an RC time constant of more than 1.25 msec is categorized as a slow power-supply ramp. To avoid errors, use the power up sequence described below.

The software reset sequence is as follows:

1. Allow V_{DD} to reach the specified minimum operating voltage, as specified in the [Recommended Operating Conditions](#) section.
2. Write a 1 to the Full Power Down bit, Bit 7 of the Configuration Register, and hold it high for the specified maximum conversion time for the initial default of 11-bits resolution. This ensures that a complete reset operation has occurred. See the Temperature Conversion Time specifications within the [Temperature-to-Digital Converter Characteristics](#) for more details.
3. Write a 0 to the Full Power Down bit to restore the LM73 to normal mode.

10 Layout

10.1 Layout Guidelines

To achieve the expected results when measuring temperature with an integrated circuit temperature sensor like the LM73, it is important to understand that the sensor measures its own die temperature. For the LM73, the best thermal path between the die and the outside world is through the LM73's pins. In the SOT-23 package, all the pins on the LM73 will have an equal effect on the die temperature. Because the pins represent a good thermal path to the LM73 die, the LM73 will provide an accurate measurement of the temperature of the printed circuit board on which it is mounted.

10.2 Layout Example

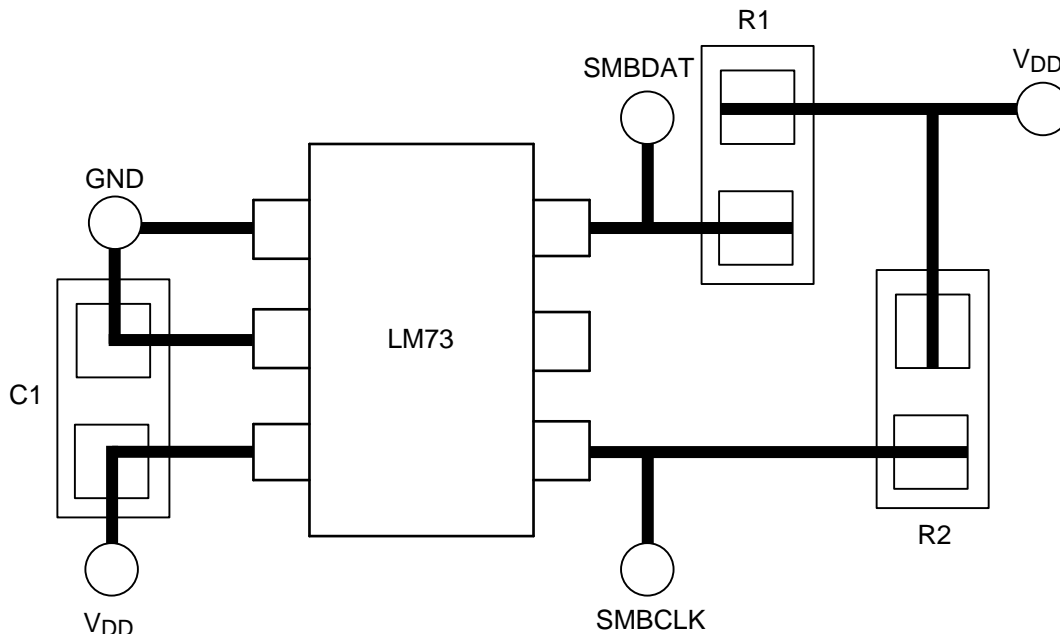

Figure 16. PBC Layout

11 Device and Documentation Support

11.1 Community Resources

The following links connect to TI community resources. Linked contents are provided "AS IS" by the respective contributors. They do not constitute TI specifications and do not necessarily reflect TI's views; see TI's [Terms of Use](#).

TI E2E™ Online Community *TI's Engineer-to-Engineer (E2E) Community*. Created to foster collaboration among engineers. At e2e.ti.com, you can ask questions, share knowledge, explore ideas and help solve problems with fellow engineers.

Design Support *TI's Design Support* Quickly find helpful E2E forums along with design support tools and contact information for technical support.

11.2 Trademarks

E2E is a trademark of Texas Instruments.
All other trademarks are the property of their respective owners.

11.3 Electrostatic Discharge Caution



These devices have limited built-in ESD protection. The leads should be shorted together or the device placed in conductive foam during storage or handling to prevent electrostatic damage to the MOS gates.

11.4 Glossary

[SLYZ022](#) — *TI Glossary*.

This glossary lists and explains terms, acronyms, and definitions.

12 Mechanical, Packaging, and Orderable Information

The following pages include mechanical, packaging, and orderable information. This information is the most current data available for the designated devices. This data is subject to change without notice and revision of this document. For browser-based versions of this data sheet, refer to the left-hand navigation.

PACKAGING INFORMATION

Orderable Device	Status (1)	Package Type	Package Drawing	Pins	Package Qty	Eco Plan (2)	Lead/Ball Finish (6)	MSL Peak Temp (3)	Op Temp (°C)	Device Marking (4/5)	Samples
LM73CIMK-0/NOPB	ACTIVE	SOT	DDC	6	1000	Green (RoHS & no Sb/Br)	CU NIPDAU	Level-1-260C-UNLIM	-40 to 150	T730	Samples
LM73CIMK-1/NOPB	ACTIVE	SOT	DDC	6	1000	Green (RoHS & no Sb/Br)	CU NIPDAU	Level-1-260C-UNLIM	-40 to 150	T731	Samples
LM73CIMKX-0/NOPB	ACTIVE	SOT	DDC	6	3000	Green (RoHS & no Sb/Br)	CU NIPDAU	Level-1-260C-UNLIM	-40 to 150	T730	Samples
LM73CIMKX-1/NOPB	ACTIVE	SOT	DDC	6	3000	Green (RoHS & no Sb/Br)	CU NIPDAU	Level-1-260C-UNLIM	-40 to 150	T731	Samples

(1) The marketing status values are defined as follows:

ACTIVE: Product device recommended for new designs.

LIFEBUY: TI has announced that the device will be discontinued, and a lifetime-buy period is in effect.

NRND: Not recommended for new designs. Device is in production to support existing customers, but TI does not recommend using this part in a new design.

PREVIEW: Device has been announced but is not in production. Samples may or may not be available.

OBSELETE: TI has discontinued the production of the device.

(2) Eco Plan - The planned eco-friendly classification: Pb-Free (RoHS), Pb-Free (RoHS Exempt), or Green (RoHS & no Sb/Br) - please check <http://www.ti.com/productcontent> for the latest availability information and additional product content details.

TBD: The Pb-Free/Green conversion plan has not been defined.

Pb-Free (RoHS): TI's terms "Lead-Free" or "Pb-Free" mean semiconductor products that are compatible with the current RoHS requirements for all 6 substances, including the requirement that lead not exceed 0.1% by weight in homogeneous materials. Where designed to be soldered at high temperatures, TI Pb-Free products are suitable for use in specified lead-free processes.

Pb-Free (RoHS Exempt): This component has a RoHS exemption for either 1) lead-based flip-chip solder bumps used between the die and package, or 2) lead-based die adhesive used between the die and leadframe. The component is otherwise considered Pb-Free (RoHS compatible) as defined above.

Green (RoHS & no Sb/Br): TI defines "Green" to mean Pb-Free (RoHS compatible), and free of Bromine (Br) and Antimony (Sb) based flame retardants (Br or Sb do not exceed 0.1% by weight in homogeneous material)

(3) MSL, Peak Temp. - The Moisture Sensitivity Level rating according to the JEDEC industry standard classifications, and peak solder temperature.

(4) There may be additional marking, which relates to the logo, the lot trace code information, or the environmental category on the device.

(5) Multiple Device Markings will be inside parentheses. Only one Device Marking contained in parentheses and separated by a "~" will appear on a device. If a line is indented then it is a continuation of the previous line and the two combined represent the entire Device Marking for that device.

(6) Lead/Ball Finish - Orderable Devices may have multiple material finish options. Finish options are separated by a vertical ruled line. Lead/Ball Finish values may wrap to two lines if the finish value exceeds the maximum column width.

Important Information and Disclaimer: The information provided on this page represents TI's knowledge and belief as of the date that it is provided. TI bases its knowledge and belief on information provided by third parties, and makes no representation or warranty as to the accuracy of such information. Efforts are underway to better integrate information from third parties. TI has taken and continues to take reasonable steps to provide representative and accurate information but may not have conducted destructive testing or chemical analysis on incoming materials and chemicals. TI and TI suppliers consider certain information to be proprietary, and thus CAS numbers and other limited information may not be available for release.

In no event shall TI's liability arising out of such information exceed the total purchase price of the TI part(s) at issue in this document sold by TI to Customer on an annual basis.

TAPE AND REEL INFORMATION

QUADRANT ASSIGNMENTS FOR PIN 1 ORIENTATION IN TAPE

*All dimensions are nominal

Device	Package Type	Package Drawing	Pins	SPQ	Reel Diameter (mm)	Reel Width W1 (mm)	A0 (mm)	B0 (mm)	K0 (mm)	P1 (mm)	W (mm)	Pin1 Quadrant
LM73CIMK-0/NOPB	SOT	DDC	6	1000	178.0	8.4	3.2	3.2	1.4	4.0	8.0	Q3
LM73CIMK-1/NOPB	SOT	DDC	6	1000	178.0	8.4	3.2	3.2	1.4	4.0	8.0	Q3
LM73CIMKX-0/NOPB	SOT	DDC	6	3000	178.0	8.4	3.2	3.2	1.4	4.0	8.0	Q3
LM73CIMKX-1/NOPB	SOT	DDC	6	3000	178.0	8.4	3.2	3.2	1.4	4.0	8.0	Q3

TAPE AND REEL BOX DIMENSIONS

*All dimensions are nominal

Device	Package Type	Package Drawing	Pins	SPQ	Length (mm)	Width (mm)	Height (mm)
LM73CIMK-0/NOPB	SOT	DDC	6	1000	210.0	185.0	35.0
LM73CIMK-1/NOPB	SOT	DDC	6	1000	210.0	185.0	35.0
LM73CIMKX-0/NOPB	SOT	DDC	6	3000	210.0	185.0	35.0
LM73CIMKX-1/NOPB	SOT	DDC	6	3000	210.0	185.0	35.0

DDC (R-PDSO-G6)

PLASTIC SMALL-OUTLINE

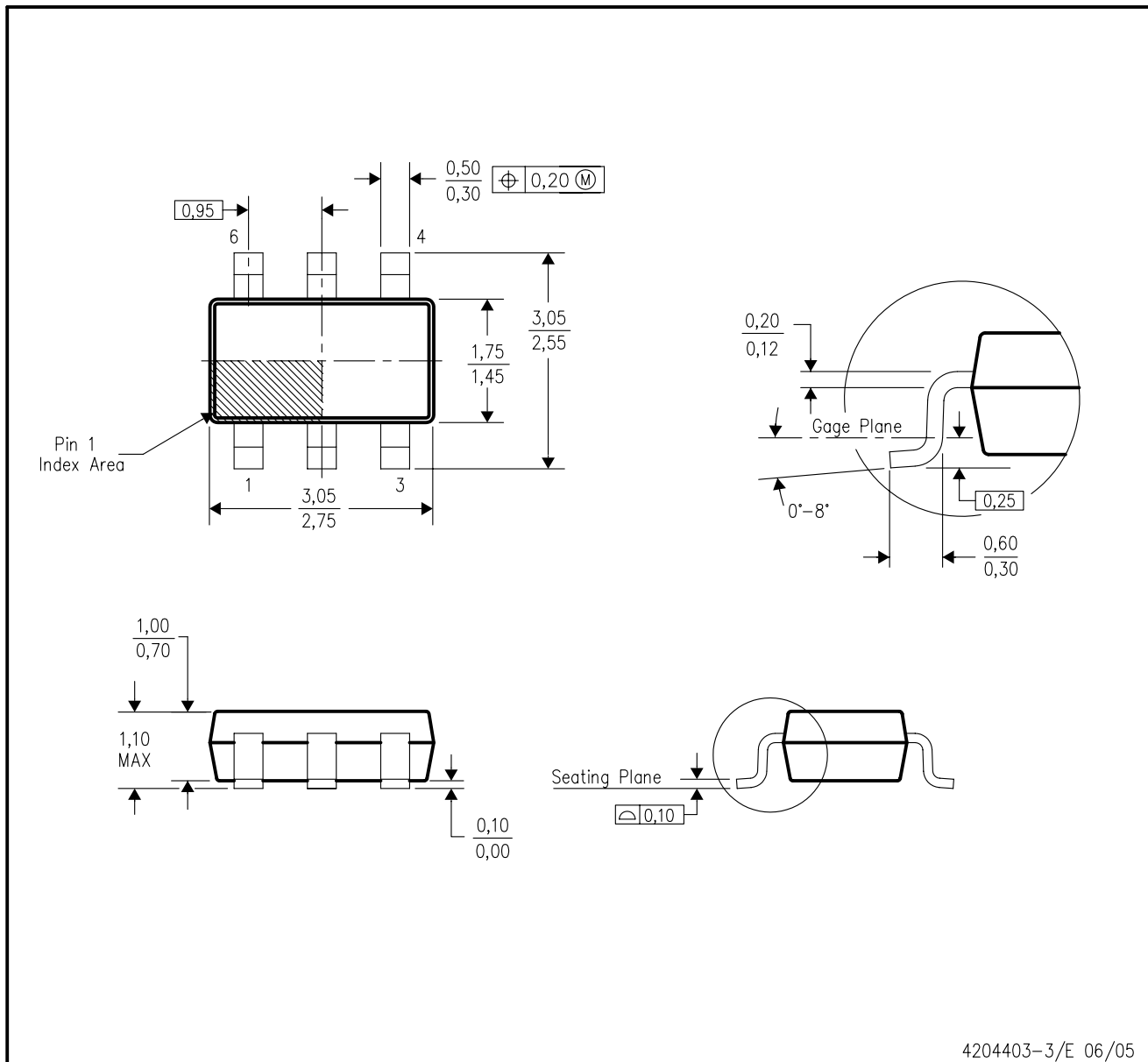

- NOTES:
- All linear dimensions are in millimeters.
 - This drawing is subject to change without notice.
 - Body dimensions do not include mold flash or protrusion.
 - Falls within JEDEC MO-193 variation AA (6 pin).

DDC (R-PDSO-G6)

PLASTIC SMALL OUTLINE

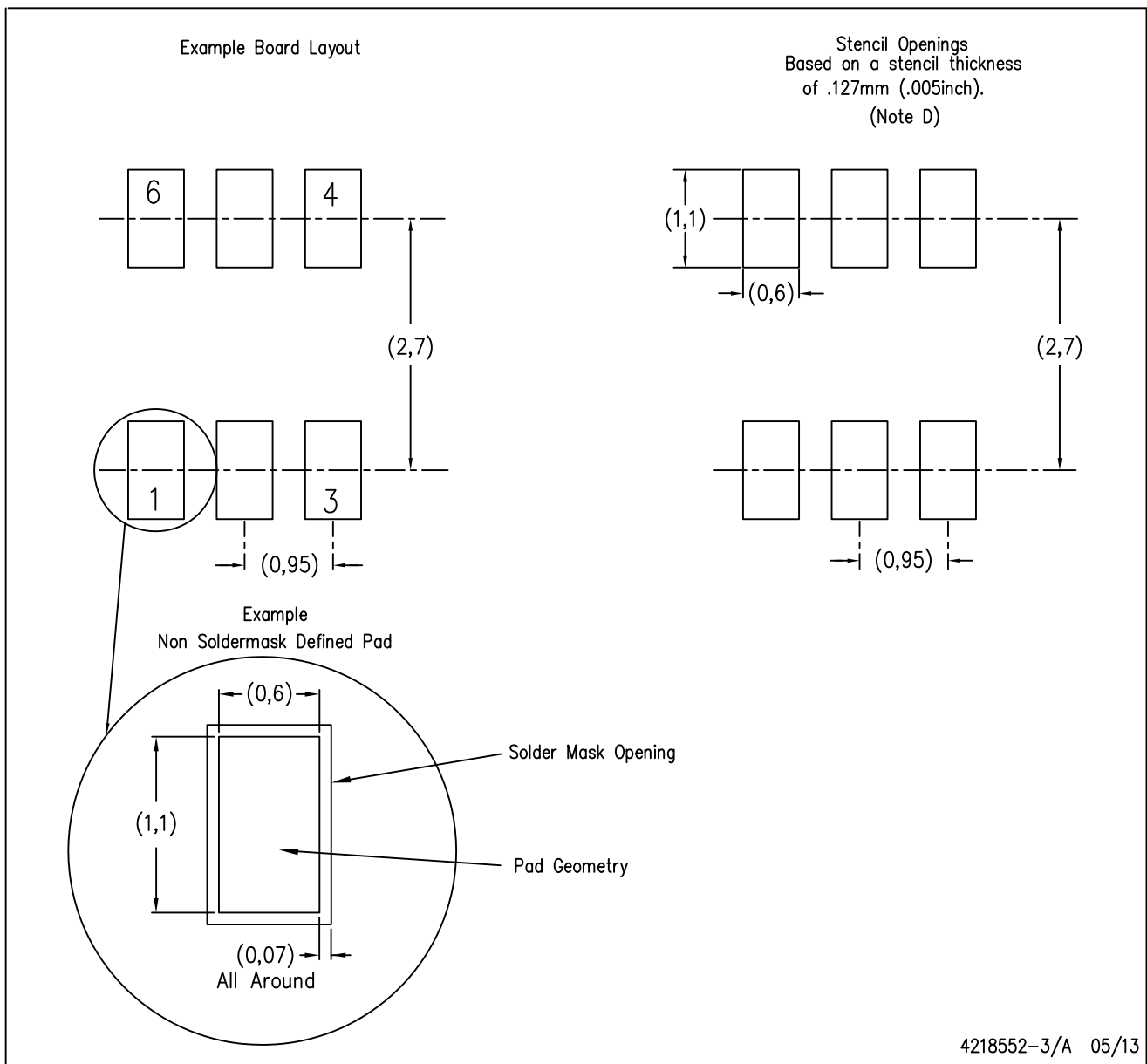

- NOTES:
- A. All linear dimensions are in millimeters.
 - B. This drawing is subject to change without notice.
 - C. Publication IPC-7351 is recommended for alternate designs.
 - D. Laser cutting apertures with trapezoidal walls and also rounding corners will offer better paste release. Customers should contact their board assembly site for stencil design recommendations. Example stencil design based on a 50% volumetric metal load solder paste. Refer to IPC-7525 for other stencil recommendations.

IMPORTANT NOTICE

Texas Instruments Incorporated and its subsidiaries (TI) reserve the right to make corrections, enhancements, improvements and other changes to its semiconductor products and services per JESD46, latest issue, and to discontinue any product or service per JESD48, latest issue. Buyers should obtain the latest relevant information before placing orders and should verify that such information is current and complete. All semiconductor products (also referred to herein as "components") are sold subject to TI's terms and conditions of sale supplied at the time of order acknowledgment.

TI warrants performance of its components to the specifications applicable at the time of sale, in accordance with the warranty in TI's terms and conditions of sale of semiconductor products. Testing and other quality control techniques are used to the extent TI deems necessary to support this warranty. Except where mandated by applicable law, testing of all parameters of each component is not necessarily performed.

TI assumes no liability for applications assistance or the design of Buyers' products. Buyers are responsible for their products and applications using TI components. To minimize the risks associated with Buyers' products and applications, Buyers should provide adequate design and operating safeguards.

TI does not warrant or represent that any license, either express or implied, is granted under any patent right, copyright, mask work right, or other intellectual property right relating to any combination, machine, or process in which TI components or services are used. Information published by TI regarding third-party products or services does not constitute a license to use such products or services or a warranty or endorsement thereof. Use of such information may require a license from a third party under the patents or other intellectual property of the third party, or a license from TI under the patents or other intellectual property of TI.

Reproduction of significant portions of TI information in TI data books or data sheets is permissible only if reproduction is without alteration and is accompanied by all associated warranties, conditions, limitations, and notices. TI is not responsible or liable for such altered documentation. Information of third parties may be subject to additional restrictions.

Resale of TI components or services with statements different from or beyond the parameters stated by TI for that component or service voids all express and any implied warranties for the associated TI component or service and is an unfair and deceptive business practice. TI is not responsible or liable for any such statements.

Buyer acknowledges and agrees that it is solely responsible for compliance with all legal, regulatory and safety-related requirements concerning its products, and any use of TI components in its applications, notwithstanding any applications-related information or support that may be provided by TI. Buyer represents and agrees that it has all the necessary expertise to create and implement safeguards which anticipate dangerous consequences of failures, monitor failures and their consequences, lessen the likelihood of failures that might cause harm and take appropriate remedial actions. Buyer will fully indemnify TI and its representatives against any damages arising out of the use of any TI components in safety-critical applications.

In some cases, TI components may be promoted specifically to facilitate safety-related applications. With such components, TI's goal is to help enable customers to design and create their own end-product solutions that meet applicable functional safety standards and requirements. Nonetheless, such components are subject to these terms.

No TI components are authorized for use in FDA Class III (or similar life-critical medical equipment) unless authorized officers of the parties have executed a special agreement specifically governing such use.

Only those TI components which TI has specifically designated as military grade or "enhanced plastic" are designed and intended for use in military/aerospace applications or environments. Buyer acknowledges and agrees that any military or aerospace use of TI components which have **not** been so designated is solely at the Buyer's risk, and that Buyer is solely responsible for compliance with all legal and regulatory requirements in connection with such use.

TI has specifically designated certain components as meeting ISO/TS16949 requirements, mainly for automotive use. In any case of use of non-designated products, TI will not be responsible for any failure to meet ISO/TS16949.

Products

Audio	www.ti.com/audio
Amplifiers	amplifier.ti.com
Data Converters	dataconverter.ti.com
DLP® Products	www.dlp.com
DSP	dsp.ti.com
Clocks and Timers	www.ti.com/clocks
Interface	interface.ti.com
Logic	logic.ti.com
Power Mgmt	power.ti.com
Microcontrollers	microcontroller.ti.com
RFID	www.ti-rfid.com
OMAP Applications Processors	www.ti.com/omap
Wireless Connectivity	www.ti.com/wirelessconnectivity

Applications

Automotive and Transportation	www.ti.com/automotive
Communications and Telecom	www.ti.com/communications
Computers and Peripherals	www.ti.com/computers
Consumer Electronics	www.ti.com/consumer-apps
Energy and Lighting	www.ti.com/energy
Industrial	www.ti.com/industrial
Medical	www.ti.com/medical
Security	www.ti.com/security
Space, Avionics and Defense	www.ti.com/space-avionics-defense
Video and Imaging	www.ti.com/video

TI E2E Community

e2e.ti.com