

## High Voltage (80V) Step Down Switching Regulator

Check for Samples: [LM5007](#)

### FEATURES

- Integrated 80V, 0.7A N-Channel Buck Switch
- Internal HV Vcc Regulator
- No Control Loop Compensation Required
- Ultra-Fast Transient Response
- On Time Varies Inversely with Line Voltage
- Operating Frequency Nearly Constant with Varying Line Voltage
- Adjustable Output Voltage
- Highly Efficient Operation
- Precision Reference
- Low Bias Current
- Intelligent Current Limit Protection
- Thermal Shutdown
- External Shutdown Control
- VSSOP-8 and WSON-8 (4mm x 4mm) Packages

### DESCRIPTION

The LM5007 Step Down Switching Regulator features all of the functions needed to implement low cost, efficient, Buck bias regulators. This high voltage regulator contains an 80 V, 0.7A N-Channel Buck Switch. The device is easy to apply and is provided in the VSSOP-8 and the thermally enhanced WSON-8 packages. The regulator is based on a hysteretic control scheme using an on time inversely proportional to  $V_{IN}$ . This feature allows the operating frequency to remain relatively constant with load and input voltage variations. The hysteretic control requires no control loop compensation, while providing very fast load transient response. An intelligent current limit is implemented in the LM5007 with forced off time that is inversely proportional to  $V_{OUT}$ . This current limiting scheme reduces load current foldback. Additional protection features include: Thermal Shutdown, Vcc undervoltage lockout, gate drive undervoltage lockout, and Max Duty Cycle limiter.

### APPLICATIONS

- Non-Isolated Buck Regulator
- Secondary High Voltage Post Regulator
- +42V Automotive Systems

### Connection Diagram

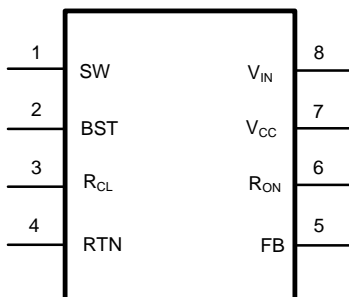
**Figure 1. 8-Lead VSSOP or WSON**

Please be aware that an important notice concerning availability, standard warranty, and use in critical applications of Texas Instruments semiconductor products and disclaimers thereto appears at the end of this data sheet.

All trademarks are the property of their respective owners.

### Typical Application Circuit and Block Diagram

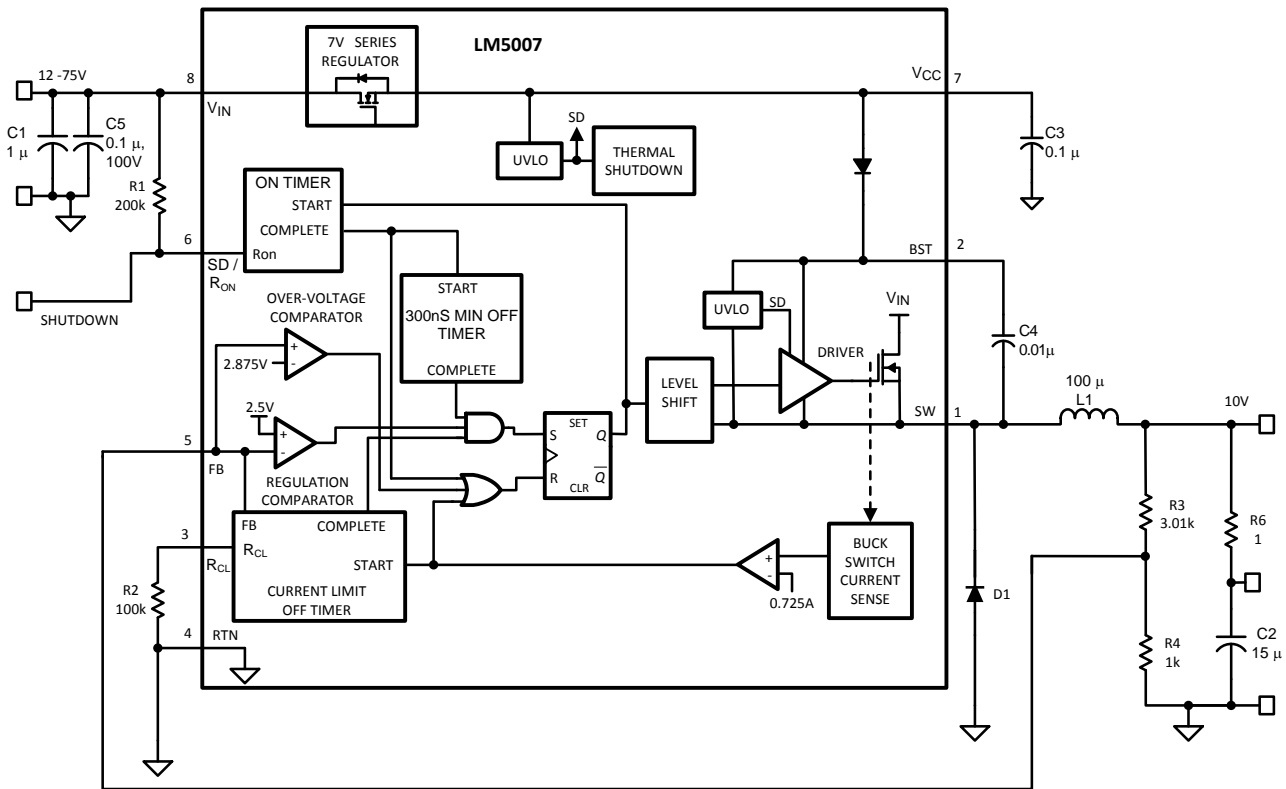

### Pin Functions

Table 1. Pin Descriptions

Pin	Name	Description	Application Information
1	SW	Switching Node	Power switching node. Connect to the LC output filter.
2	BST	Boost Boot-strap capacitor input	An external capacitor is required between the BST and the SW pins. A 0.01uF ceramic capacitor is recommended. An internal diode between Vcc and BST completes the Buck gate drive bias network.
3	R <sub>CL</sub>	Current Limit OFF time programming pin $T_{off} = 10^{-5} / (0.59 + (FB / 7.22 \times 10^{-6} \times R_{CL}))$	A resistor between this pin and RTN determines the variation of off time, along with the FB pin voltage, per cycle while in current limit. The off time is preset to 17uS if FB =0V and decreases as the FB pin voltage increases.
4	RTN	Circuit Ground	
5	FB	Feedback Signal from Regulated Output	This pin is connected to the inverting input of the internal regulation comparator. The regulation threshold is 2.5V.
6	R <sub>ON</sub>	On time set pin $T_{on} = 1.42 \times 10^{-10} R_{ON} / V_{in}$	A resistor between this pin and Vin sets the switch on time as a function of Vin. The minimum recommended on time is 300ns at the maximum input voltage.
7	Vcc	Output from the internal high voltage bias regulator. V <sub>CC</sub> is nominally regulated to 7 V.	If an auxiliary voltage is available to raise the voltage on this pin, above the regulation set point (7V), the internal series pass regulator will shutdown, reducing the IC power dissipation. Do not exceed 14V. This output provides gate drive power for the internal Buck switch. An internal diode is provided between this pin and the BST pin. A local 0.1uF decoupling capacitor is recommended. Series pass regulator is current limited to 10mA.
8	Vin	Input supply voltage	Recommended operating range: 9V to 75V.
-	EP	Exposed PAD, underside of the WSON package option	Internally bonded to the die substrate. Connect to GND potential for low thermal impedance.



These devices have limited built-in ESD protection. The leads should be shorted together or the device placed in conductive foam during storage or handling to prevent electrostatic damage to the MOS gates.

### Absolute Maximum Ratings <sup>(1)</sup>

$V_{IN}$ to GND	80V
BST to GND	94V
SW to GND (Steady State)	-1V
ESD Rating, Human Body Model <sup>(2)</sup>	2kV
Machine Model	200V
BST to $V_{CC}$	80V
BST to SW	14V
$V_{CC}$ to GND	14V
All Other Inputs to GND	-0.3 to 7V
Lead Temperature (Soldering 4 sec)	260°C
Storage Temperature Range	-55°C to +150°C

- (1) Absolute Maximum Ratings are limits beyond which damage to the device may occur. Operating Ratings are conditions under which operation of the device is intended to be functional. For specifications and test conditions, see the Electrical Characteristics.
- (2) The human body model is a 100pF capacitor discharge through a 1.5kΩ resistor into each pin. The machine model is a 200pF capacitor discharged directly into each pin. The machine model ESD compliance level for Pin 5 is 150V. The human body ESD compliance level for Pin 7 and 8 is 1000V.

### Operating Ratings <sup>(1)</sup>

$V_{IN}$	9V to 75V
Junction Temperature	-40°C to + 125°C

- (1) Absolute Maximum Ratings are limits beyond which damage to the device may occur. Operating Ratings are conditions under which operation of the device is intended to be functional. For specifications and test conditions, see the Electrical Characteristics.

## Electrical Characteristics

Specifications with standard typeface are for  $T_J = 25^\circ\text{C}$ , and those with **boldface** type apply over full **Operating Junction Temperature range**.  $V_{IN} = 48\text{V}$ , unless otherwise stated <sup>(1)</sup>.

Symbol	Parameter	Conditions	Min	Typ	Max	Unit
<b>Startup Regulator</b>						
$V_{CC}$ Reg	$V_{CC}$ Regulator Output		<b>6.6</b>	7	<b>7.4</b>	V
	$V_{CC}$ Current Limit <sup>(2)</sup>			11		mA
<b><math>V_{CC}</math> Supply</b>						
	$V_{CC}$ undervoltage Lockout Voltage ( $V_{CC}$ increasing)			6.3		V
	$V_{CC}$ Undervoltage Hysteresis			206		mV
	$V_{CC}$ UVLO Delay (filter)			3		$\mu\text{s}$
	Operating Current (ICC)	Non-Switching, FB = 3V		500	<b>675</b>	$\mu\text{A}$
	Shutdown/Standby Current	$R_{ON} = 0\text{V}$		100	<b>200</b>	$\mu\text{A}$
<b>Switch Characteristics</b>						
	Buck Switch $R_{ds(on)}$	$I_{TEST} = 200\text{mA}$ , $V_{BST} - V_{SW} = 6.3\text{V}$ <sup>(3)</sup>		0.74	<b>1.34</b>	$\Omega$
	Gate Drive UVLO (VBST – VSW)	Rising	<b>3.4</b>	4.5	<b>5.5</b>	V
	Gate Drive UVLO Hysteresis			400		mV
	Breakdown Voltage, $V_{IN}$ to Ground	$T_J = 25^\circ\text{C}$	<b>80</b>			V
		$T_J = -40^\circ\text{C}$ to $+125^\circ\text{C}$	<b>76</b>			V
	Breakdown Voltage, BST to $V_{CC}$	$T_J = 25^\circ\text{C}$	<b>80</b>			V
		$T_J = -40^\circ\text{C}$ to $+125^\circ\text{C}$	<b>76</b>			V
<b>Current Limit</b>						
	Current Limit Threshold		<b>535</b>	725	<b>900</b>	mA
	Current Limit Response Time	$I_{switch}$ Overdrive = 0.1A Time to Switch Off		225		ns
	OFF time generator (test 1)	FB=0V, RCL = 100K		17		$\mu\text{s}$
	OFF time generator (test 2)	FB=2.3V, RCL = 100K		2.65		$\mu\text{s}$
<b>On Time Generator</b>						
	TON -1	$V_{in} = 10\text{V}$ , $R_{on} = 200\text{K}$	<b>2.15</b>	2.77	<b>3.5</b>	$\mu\text{s}$
	TON -2	$V_{in} = 75\text{V}$ , $R_{on} = 200\text{K}$	<b>290</b>	390	<b>490</b>	ns
	Remote Shutdown Threshold	Rising	<b>0.45</b>	0.7	<b>1.1</b>	V
	Remote Shutdown Hysteresis			40		mV
<b>Minimum Off Time</b>						
	Minimum Off Timer	FB = 0V		300		ns
<b>Regulation and OV Comparators</b>						
	FB Reference Threshold	Internal reference, Trip point for switch ON	<b>2.445</b>	2.5	<b>2.550</b>	V
	FB Over-Voltage Threshold	Trip point for switch OFF		2.875		V
	FB Bias Current			100		nA
<b>Thermal Shutdown</b>						
$T_{sd}$	Thermal Shutdown Temp.			165		$^\circ\text{C}$
	Thermal Shutdown Hysteresis			25		$^\circ\text{C}$
<b>Thermal Resistance</b>						
$\theta_{JA}$	Junction to Ambient	VSSOP-8 Package		200		$^\circ\text{C/W}$
		WSOP-8 Package		40		$^\circ\text{C/W}$

- (1) All electrical characteristics having room temperature limits are tested during production with  $T_A = T_J = 25^\circ\text{C}$ . All hot and cold limits are specified by correlating the electrical characteristics to process and temperature variations and applying statistical process control.
- (2) The  $V_{CC}$  output is intended as a self bias for the internal gate drive power and control circuits. Device thermal limitations limit external loading.
- (3) For devices in the WSON-8 package, the  $R_{ds(on)}$  limits are specified by design characterization data only.

## DETAILED OPERATING DESCRIPTION

The LM5007 Step Down Switching Regulator features all of the functions needed to implement low cost, efficient, Buck bias regulators. This high voltage regulator contains an 80V, 0.7A N-Channel Buck Switch. The device is easy to apply and is provided in the VSSOP-8 and the thermally enhanced WSON-8 packages. The regulator is based on a hysteretic control scheme using an on time inversely proportional to  $V_{in}$ . This feature allows the operating frequency to remain relatively constant with load and input voltage variations. The hysteretic control requires no control loop compensation, while providing very fast load transient response. An intelligent current limit scheme is implemented in the LM5007 with forced off time, after current limit detection, which is inversely proportional to  $V_{out}$ . This current limiting scheme reduces load current foldback. Additional protection features include: Thermal Shutdown,  $V_{cc}$  undervoltage lockout, Gate drive undervoltage lockout and Max Duty Cycle limiter. The LM5007 can be applied in numerous applications to efficiently regulate step down higher voltage inputs. This regulator is well suited for 48 Volt Telcom and the new 42V Automotive power bus ranges.

### Hysteretic Control Circuit Overview

The LM5007 is a Buck DC-DC regulator that uses an on time control scheme. The on time is programmed by an external resistor and varies inversely with line input voltage ( $V_{in}$ ). The core regulation elements of the LM5007 are the feedback comparator and the on time one-shot. The regulator output voltage is sensed at the feedback pin (FB) and is compared to an internal reference voltage (2.5V). If the FB signal is below the reference voltage, the buck switch is turned on for a fixed time pulse determined by the line voltage and a programming resistor ( $R_{ON}$ ). Following the on period the switch will remain off for at least the minimum off timer period of 300ns. If the FB pin voltage is still below the reference after the 300ns off time, the switch will turn on again for another on time period. This switching behavior will continue until the FB pin voltage reaches the reference voltage level.

The LM5007 operates in discontinuous conduction mode at light load currents or continuous conduction mode at heavier load currents. In discontinuous conduction mode, current through the output inductor starts at zero and ramps up to a peak value during the buck switch on time and then back to zero during the off time. The inductor current remains at zero until the next on time period starts when FB falls below the internal reference. In discontinuous mode the operating frequency can be relatively low and will vary with load. Therefore at light loads the conversion efficiency is maintained, since the switching losses decrease with the reduction in load current and switching frequency. The approximate discontinuous mode operating frequency can be calculated as follows:

$$F = \frac{V_{OUT}^2 \times L}{1 \times 10^{-20} \times R_{Load} \times (R_{ON})^2} \quad (1)$$

In continuous conduction mode, current flows continuously through the inductor and never ramps down to zero. In this mode the operating frequency is greater than the discontinuous mode frequency and remains relatively constant with load and line variations. The approximate continuous mode operating frequency can be calculated as follows:

$$F = \frac{V_{OUT}}{1.42 \times 10^{-10} \times R_{ON}} \quad (2)$$

The output voltage ( $V_{out}$ ) can be programmed by two external resistors as shown in [Figure 2](#). The regulation point can be calculated as follows:

$$V_{OUT} = 2.5 \times (R1 + R2) / R2 \quad (3)$$

The feedback comparator in hysteretic regulators depend upon the output ripple voltage to switch the output transistor on and off at regular intervals. In order for the internal comparator to respond quickly to changes in output voltage, proportional to inductor current, a minimum amount of capacitor Equivalent Series Resistance (ESR) is required. A ripple voltage of 25mV to 50mV is recommended at the feedback pin (FB) for stable operation. In cases where the intrinsic capacitor ESR is too small, additional series resistance may be added.

For applications where lower output voltage ripple is required the load can be connected directly to the low ESR output capacitor, as shown in [Figure 2](#). The series resistor (R) will degrade the load regulation. Another technique for enhancing the ripple voltage at the FB pin is to place a capacitor in parallel with the feedback divider resistor R1. The addition of the capacitor reduces the attenuation of the ripple voltage from the feedback divider

## High Voltage Bias Regulator

The LM5007 contains an internal high voltage bias regulator. The input pin ( $V_{in}$ ) can be connected directly to line voltages from 9 V to 75 V. To avoid supply voltage transients due to long lead inductances on the input pin ( $V_{in}$  Pin 8), it is always recommended to connect low ESR ceramic chip capacitor ( $\approx 0.1\mu\text{F}$ ) between "Vin" pin and "RTN" pin (pin 4), located close to LM5007. The regulator is internally current limited to 10mA. Upon power up, the regulator is enabled and sources current into an external capacitor connected to the  $V_{cc}$  pin. When the voltage on the  $V_{cc}$  pin reaches the regulation point of 7V, the controller output is enabled.

An external auxiliary supply voltage can be applied to the  $V_{cc}$  pin. If the auxiliary voltage is greater than 7 V, the internal regulator will essentially shutoff, thus reducing internal power dissipation.

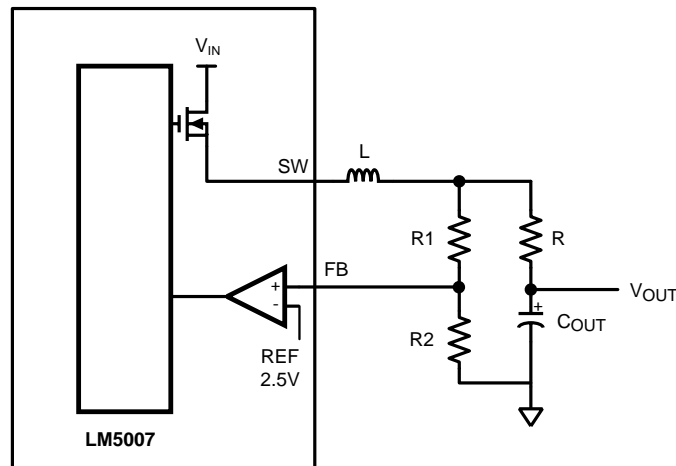

Figure 2. Low Ripple Output Configuration

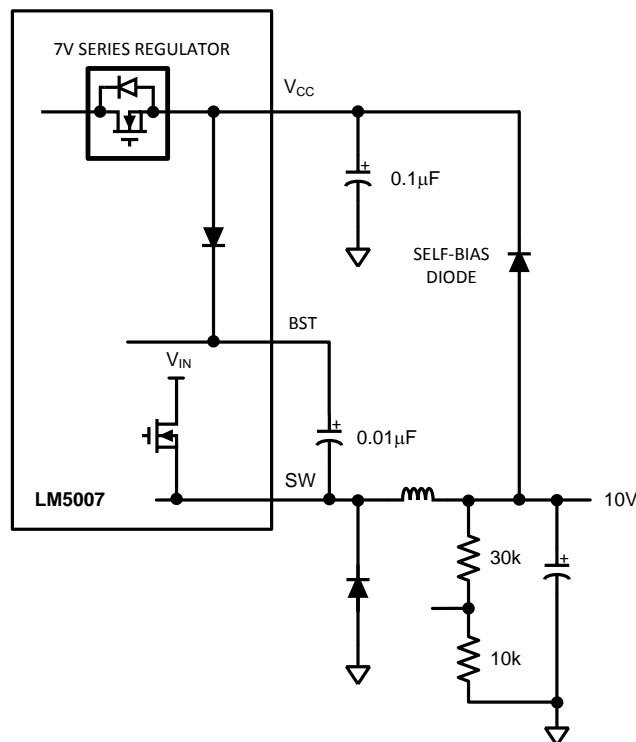

Figure 3. Self Biased Configuration

## Over-Voltage Comparator

The over-voltage comparator is provided to protect the output from overvoltage conditions due to sudden input line voltage changes or output loading changes. The over-voltage comparator monitors the FB pin versus an internal 2.875V reference (OV\_REF). If the voltage at FB rises above OV\_REF the comparator immediately terminates the buck switch on time pulse.

## ON Time generator and Shutdown

The on time of the LM5007 is set inversely proportional to the input voltage by an external resistor connected between Ron and Vin. The Ron terminal is a low impedance input biased at approximately 1.5V. Thus the current through the resistor and into the Ron terminal is approximately proportional to Vin and used internally to control the on timer. This scheme of input voltage feed-forward hysteretic operation achieves nearly constant operational frequency over varying line and load conditions. The on time equation for the LM5007 is :

$$T_{on} = 1.42 \times 10^{-10} \times R_{ON} / V_{IN} \quad (4)$$

The R<sub>ON</sub> pin of the LM5007 also provides a shutdown function which disables the regulator and significantly decreases quiescent power dissipation. By pulling the R<sub>ON</sub> pin to below 0.7V logic threshold activates the low power shutdown mode. The V<sub>IN</sub> quiescent current in the shutdown mode is approximately 100µA internal to the LM5007 plus the current in the R<sub>ON</sub> resistor.

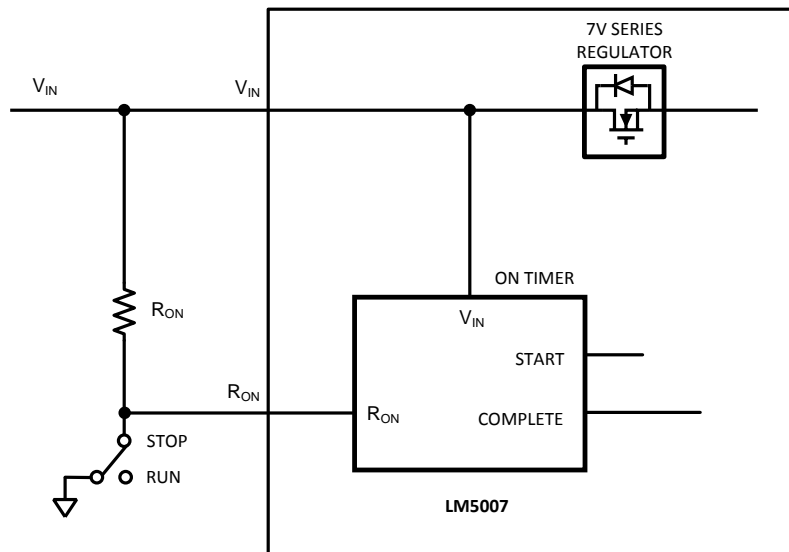

Figure 4. Shutdown Implementation

## Current Limit

The LM5007 contains an intelligent current limit off timer intended to reduce the foldback characteristic inherent with fixed off-time over-current protection. If the current in the Buck switch exceeds 725mA the present cycle on time is immediately terminated (cycle by cycle current limit). Following the termination of the cycle a non-resettable current limit off timer is initiated. The duration of the off time is a function of the external resistor (R<sub>CL</sub>) and the FB pin voltage. When the FB pin voltage equals zero, the current limit off time is internally preset to 17µS. This condition occurs in short circuit operation when a maximum amount of off time is required.

In cases of overload (not complete short circuit) the current limit off time can be reduced as a function of the output voltage (measured at the FB pin). Reducing the off time with smaller overloads reduces the amount of foldback and also reduces the initial start-up time. The current limit off time for a given FB pin voltage and R<sub>CL</sub> resistor can be calculated by the following equation:

$$T_{OFF} = \frac{10^{-5}}{0.59 + \left( \frac{V_{FB}}{7.22 \times 10^{-6} \times R_{CL}} \right)} \quad (5)$$

Applications utilizing low resistance inductors and/or a low voltage drop rectifier may require special evaluation at high line, short circuit conditions. In this special case the preset  $17\mu\text{s}$  ( $\text{FB} = 0\text{V}$ ) off time may be insufficient to balance the inductor volt\*time product. Additional inductor resistance, output resistance or a larger voltage drop rectifier may be necessary to balance the inductor cycle volt\*time product and limit the short circuit current.

## N-Channel Buck Switch and Driver

The LM5007 integrates an N-Channel Buck switch and associated floating high voltage gate driver. This gate driver circuit works in conjunction with an external bootstrap capacitor and an internal high voltage diode. The bootstrap capacitor is charged by  $V_{\text{CC}}$  through the internal high voltage diode. A  $0.01\mu\text{F}$  ceramic capacitor connected between the BST pin and SW pin is recommended.

During each cycle when the Buck switch turns off, the SW pin is approximately  $0\text{V}$ . When the SW pin voltage is low, the bootstrap capacitor will be charged from  $V_{\text{CC}}$  through the internal diode. The minimum off timer, set to  $300\text{ns}$ , ensures that there will be a minimum interval every cycle to recharge the bootstrap capacitor.

An external re-circulating diode from the SW pin to ground is necessary to carry the inductor current after the internal Buck switch turns off. This external diode must be of the Ultra-fast or Schottky type to reduce turn-on losses and current over-shoot. The reverse voltage rating of the re-circulating diode must be greater than the maximum line input voltage.

## Thermal Protection

Internal Thermal Shutdown circuitry is provided to protect the integrated circuit in the event the maximum junction temperature is exceeded. When thermal protection is activated, typically at  $165$  degrees Celsius, the controller is forced into a low power reset state, disabling the output driver. This feature is provided to prevent catastrophic failures from accidental device overheating.

## Minimum Load Current

A minimum load current of  $1\text{ mA}$  is required to maintain proper operation. If the load current falls below that level, the bootstrap capacitor may discharge during the long off-time, and the circuit will either shutdown, or cycle on and off at a low frequency. If the load current is expected to drop below  $1\text{ mA}$  in the application, the feedback resistors should be chosen low enough in value so they provide the minimum required current at nominal  $V_{\text{OUT}}$ .

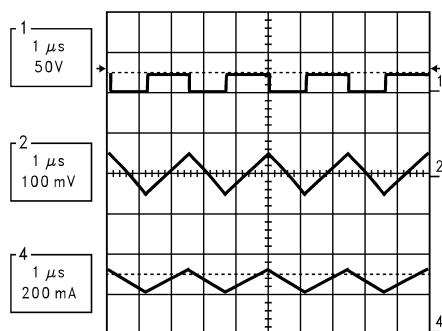

**Figure 5. Operational Waveforms:  
LM5007 Operation:**  
 $V_{\text{OUT}} = 10\text{V}$ ,  $V_{\text{IN}} = 20\text{V}$ ,  $I_{\text{OUT}} = 250\text{mA}$   
CH1: Switch Node, CH2:  $V_{\text{OUT}}$  (AC),  
CH4: Inductor Current

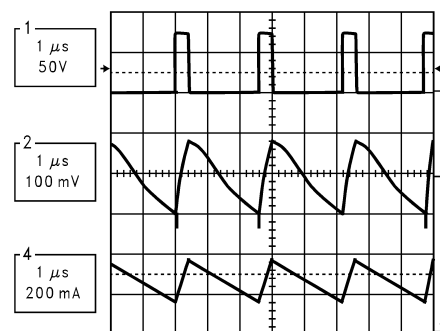

**Figure 6. Operational Waveforms:  
LM5007 Operation:**  
 $V_{\text{OUT}} = 10\text{V}$ ,  $V_{\text{IN}} = 75\text{V}$ ,  $I_{\text{OUT}} = 250\text{mA}$   
CH1: Switch Node, CH2:  $V_{\text{OUT}}$  (AC),  
CH4: Inductor Current



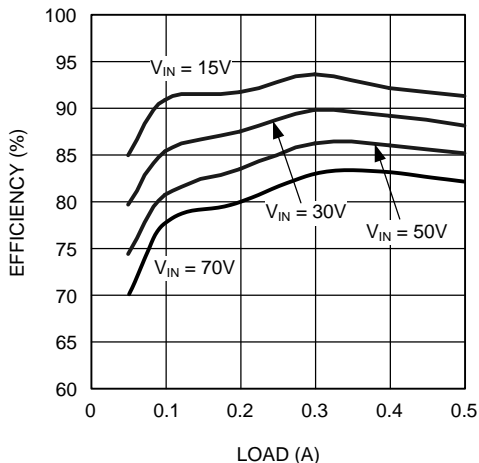

Figure 7. LM5007 10V Output Efficiency

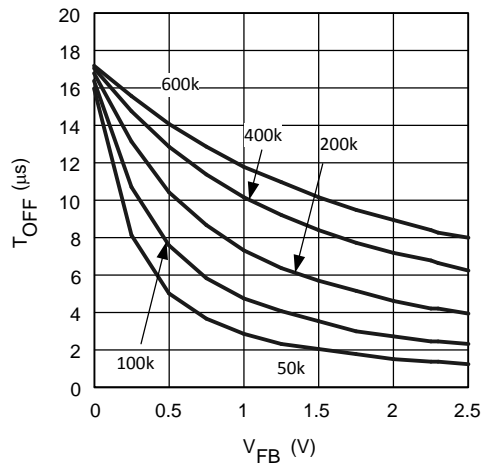

Figure 8. Current Limit  $V_{FB}$  vs  $T_{OFF}$   
 $R_{CL} = 50k - 600k$

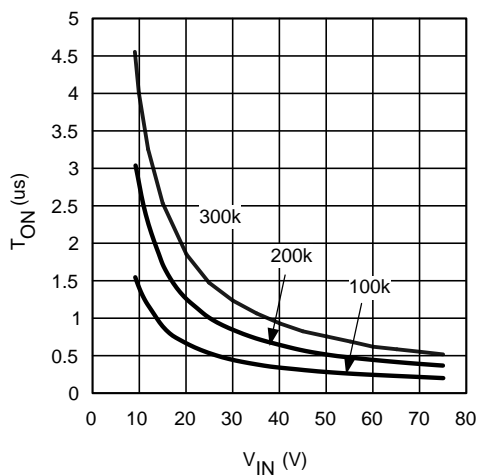

Figure 9.  $V_{IN}$  vs  $T_{ON}$   
 $R_{ON} = 100k, 200k, 300k$

Table 2. 10V, 400mA Demo Board Bill of Materials

ITEM	PART NUMBER	DESCRIPTION	VALUE
C1	C4532X7R2A105M	CAPACITOR, CER, TDK	1µ, 100V
C2	C4532X7R1E156M	CAPACITOR, CER, TDK	15µ, 25V
C3	C1206C104K5RAC	CAPACITOR, CER, KEMET	0.1µ, 50V
C4	C1206C103K5RAC	CAPACITOR, CER, KEMET	0.01µ, 50V
C5	C3216X7R2A104KT	CAPACITOR, CER, TDK	0.1µ, 100V
D1	MURA110T3	DIODE, 100V, ON SEMI	
L1	SLF7045T-101MR60-1	BUCK INDUCTOR, TDK	100µH
R1	CRCW12062003F	RESISTOR	200K
R2	CRCW12061003F	RESISTOR	100K
R3	CRCW12063011F	RESISTOR	3.01K
R4	CRCW12061001F	RESISTOR	1K
R5	CRCW12061R00F	RESISTOR	1
U1	LM5007	REGULATOR, TI	

## REVISION HISTORY

Changes from Revision E (March 2013) to Revision F	Page
• Changed layout of National Data Sheet to TI format .....	<a href="#">9</a>

**PACKAGING INFORMATION**

Orderable Device	Status (1)	Package Type	Package Drawing	Pins	Package Qty	Eco Plan (2)	Lead/Ball Finish	MSL Peak Temp (3)	Op Temp (°C)	Top-Side Markings (4)	Samples
LM5007MM	ACTIVE	VSSOP	DGK	8	1000	TBD	Call TI	Call TI	-40 to 125	S81B	<a href="#">Samples</a>
LM5007MM/NOPB	ACTIVE	VSSOP	DGK	8	1000	Green (RoHS & no Sb/Br)	CU SN	Level-1-260C-UNLIM	-40 to 125	S81B	<a href="#">Samples</a>
LM5007MMX	ACTIVE	VSSOP	DGK	8	3500	TBD	Call TI	Call TI	-40 to 125	S81B	<a href="#">Samples</a>
LM5007MMX/NOPB	ACTIVE	VSSOP	DGK	8	3500	Green (RoHS & no Sb/Br)	CU SN	Level-1-260C-UNLIM	-40 to 125	S81B	<a href="#">Samples</a>
LM5007SD	ACTIVE	WSON	NGT	8	1000	TBD	Call TI	Call TI	-40 to 125	L00031B	<a href="#">Samples</a>
LM5007SD/NOPB	ACTIVE	WSON	NGT	8	1000	Green (RoHS & no Sb/Br)	SN	Level-1-260C-UNLIM	-40 to 125	L00031B	<a href="#">Samples</a>
LM5007SDX/NOPB	ACTIVE	WSON	NGT	8	4500	Green (RoHS & no Sb/Br)	SN	Level-1-260C-UNLIM	-40 to 125	L00031B	<a href="#">Samples</a>

(1) The marketing status values are defined as follows:

**ACTIVE:** Product device recommended for new designs.

**LIFEBUY:** TI has announced that the device will be discontinued, and a lifetime-buy period is in effect.

**NRND:** Not recommended for new designs. Device is in production to support existing customers, but TI does not recommend using this part in a new design.

**PREVIEW:** Device has been announced but is not in production. Samples may or may not be available.

**OBSOLETE:** TI has discontinued the production of the device.

(2) Eco Plan - The planned eco-friendly classification: Pb-Free (RoHS), Pb-Free (RoHS Exempt), or Green (RoHS & no Sb/Br) - please check <http://www.ti.com/productcontent> for the latest availability information and additional product content details.

**TBD:** The Pb-Free/Green conversion plan has not been defined.

**Pb-Free (RoHS):** TI's terms "Lead-Free" or "Pb-Free" mean semiconductor products that are compatible with the current RoHS requirements for all 6 substances, including the requirement that lead not exceed 0.1% by weight in homogeneous materials. Where designed to be soldered at high temperatures, TI Pb-Free products are suitable for use in specified lead-free processes.

**Pb-Free (RoHS Exempt):** This component has a RoHS exemption for either 1) lead-based flip-chip solder bumps used between the die and package, or 2) lead-based die adhesive used between the die and leadframe. The component is otherwise considered Pb-Free (RoHS compatible) as defined above.

**Green (RoHS & no Sb/Br):** TI defines "Green" to mean Pb-Free (RoHS compatible), and free of Bromine (Br) and Antimony (Sb) based flame retardants (Br or Sb do not exceed 0.1% by weight in homogeneous material)

(3) MSL, Peak Temp. -- The Moisture Sensitivity Level rating according to the JEDEC industry standard classifications, and peak solder temperature.

(4) Multiple Top-Side Markings will be inside parentheses. Only one Top-Side Marking contained in parentheses and separated by a "~" will appear on a device. If a line is indented then it is a continuation of the previous line and the two combined represent the entire Top-Side Marking for that device.

**Important Information and Disclaimer:** The information provided on this page represents TI's knowledge and belief as of the date that it is provided. TI bases its knowledge and belief on information provided by third parties, and makes no representation or warranty as to the accuracy of such information. Efforts are underway to better integrate information from third parties. TI has taken and continues to take reasonable steps to provide representative and accurate information but may not have conducted destructive testing or chemical analysis on incoming materials and chemicals. TI and TI suppliers consider certain information to be proprietary, and thus CAS numbers and other limited information may not be available for release.

In no event shall TI's liability arising out of such information exceed the total purchase price of the TI part(s) at issue in this document sold by TI to Customer on an annual basis.

**TAPE AND REEL INFORMATION**

**QUADRANT ASSIGNMENTS FOR PIN 1 ORIENTATION IN TAPE**

\*All dimensions are nominal

Device	Package Type	Package Drawing	Pins	SPQ	Reel Diameter (mm)	Reel Width W1 (mm)	A0 (mm)	B0 (mm)	K0 (mm)	P1 (mm)	W (mm)	Pin1 Quadrant
LM5007MM	VSSOP	DGK	8	1000	178.0	12.4	5.3	3.4	1.4	8.0	12.0	Q1
LM5007MM/NOPB	VSSOP	DGK	8	1000	178.0	12.4	5.3	3.4	1.4	8.0	12.0	Q1
LM5007MMX	VSSOP	DGK	8	3500	330.0	12.4	5.3	3.4	1.4	8.0	12.0	Q1
LM5007MMX/NOPB	VSSOP	DGK	8	3500	330.0	12.4	5.3	3.4	1.4	8.0	12.0	Q1
LM5007SD	WSOP	NGT	8	1000	178.0	12.4	4.3	4.3	1.3	8.0	12.0	Q1
LM5007SD/NOPB	WSOP	NGT	8	1000	178.0	12.4	4.3	4.3	1.3	8.0	12.0	Q1
LM5007SDX/NOPB	WSOP	NGT	8	4500	330.0	12.4	4.3	4.3	1.3	8.0	12.0	Q1

**TAPE AND REEL BOX DIMENSIONS**

\*All dimensions are nominal

Device	Package Type	Package Drawing	Pins	SPQ	Length (mm)	Width (mm)	Height (mm)
LM5007MM	VSSOP	DGK	8	1000	203.0	190.0	41.0
LM5007MM/NOPB	VSSOP	DGK	8	1000	203.0	190.0	41.0
LM5007MMX	VSSOP	DGK	8	3500	367.0	367.0	35.0
LM5007MMX/NOPB	VSSOP	DGK	8	3500	367.0	367.0	35.0
LM5007SD	WSON	NGT	8	1000	203.0	190.0	41.0
LM5007SD/NOPB	WSON	NGT	8	1000	203.0	190.0	41.0
LM5007SDX/NOPB	WSON	NGT	8	4500	367.0	367.0	35.0

DGK (S-PDSO-G8)

PLASTIC SMALL-OUTLINE PACKAGE

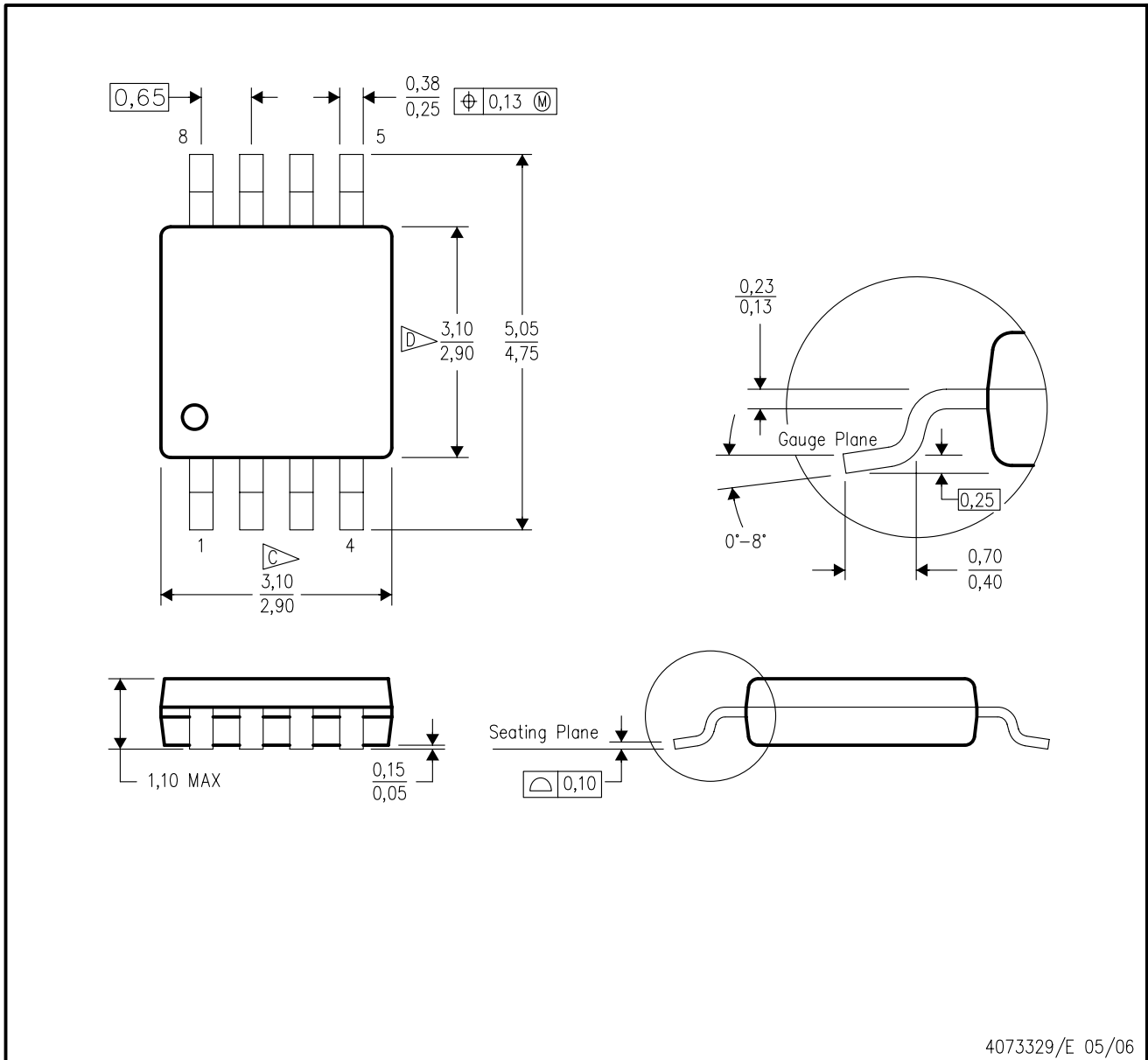

4073329/E 05/06

- NOTES:
- A. All linear dimensions are in millimeters.
  - B. This drawing is subject to change without notice.
  - C. Body length does not include mold flash, protrusions, or gate burrs. Mold flash, protrusions, or gate burrs shall not exceed 0.15 per end.
  - D. Body width does not include interlead flash. Interlead flash shall not exceed 0.50 per side.
  - E. Falls within JEDEC MO-187 variation AA, except interlead flash.

NGT0008A

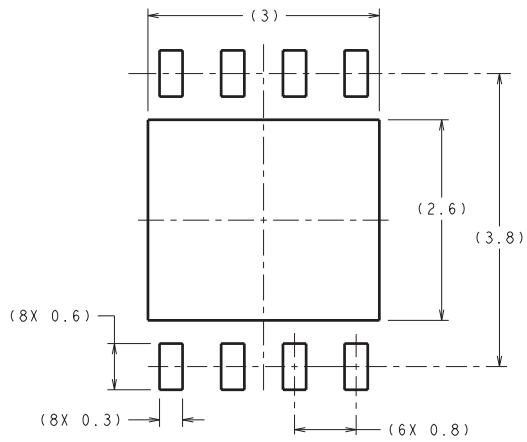

DIMENSIONS ARE IN MILLIMETERS  
DIMENSIONS IN ( ) FOR REFERENCE ONLY



RECOMMENDED LAND PATTERN

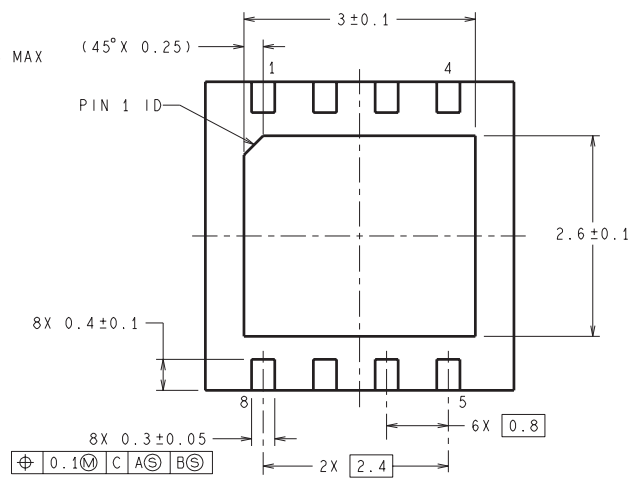
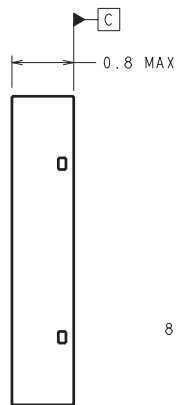
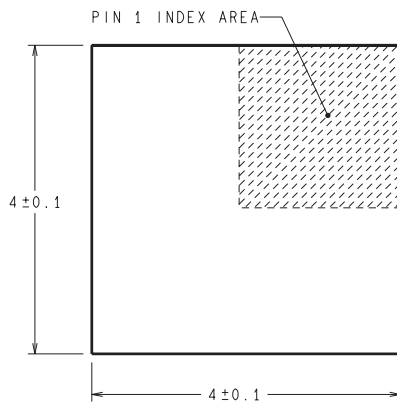

SDC08A (Rev A)



## IMPORTANT NOTICE

Texas Instruments Incorporated and its subsidiaries (TI) reserve the right to make corrections, enhancements, improvements and other changes to its semiconductor products and services per JESD46, latest issue, and to discontinue any product or service per JESD48, latest issue. Buyers should obtain the latest relevant information before placing orders and should verify that such information is current and complete. All semiconductor products (also referred to herein as "components") are sold subject to TI's terms and conditions of sale supplied at the time of order acknowledgment.

TI warrants performance of its components to the specifications applicable at the time of sale, in accordance with the warranty in TI's terms and conditions of sale of semiconductor products. Testing and other quality control techniques are used to the extent TI deems necessary to support this warranty. Except where mandated by applicable law, testing of all parameters of each component is not necessarily performed.

TI assumes no liability for applications assistance or the design of Buyers' products. Buyers are responsible for their products and applications using TI components. To minimize the risks associated with Buyers' products and applications, Buyers should provide adequate design and operating safeguards.

TI does not warrant or represent that any license, either express or implied, is granted under any patent right, copyright, mask work right, or other intellectual property right relating to any combination, machine, or process in which TI components or services are used. Information published by TI regarding third-party products or services does not constitute a license to use such products or services or a warranty or endorsement thereof. Use of such information may require a license from a third party under the patents or other intellectual property of the third party, or a license from TI under the patents or other intellectual property of TI.

Reproduction of significant portions of TI information in TI data books or data sheets is permissible only if reproduction is without alteration and is accompanied by all associated warranties, conditions, limitations, and notices. TI is not responsible or liable for such altered documentation. Information of third parties may be subject to additional restrictions.

Resale of TI components or services with statements different from or beyond the parameters stated by TI for that component or service voids all express and any implied warranties for the associated TI component or service and is an unfair and deceptive business practice. TI is not responsible or liable for any such statements.

Buyer acknowledges and agrees that it is solely responsible for compliance with all legal, regulatory and safety-related requirements concerning its products, and any use of TI components in its applications, notwithstanding any applications-related information or support that may be provided by TI. Buyer represents and agrees that it has all the necessary expertise to create and implement safeguards which anticipate dangerous consequences of failures, monitor failures and their consequences, lessen the likelihood of failures that might cause harm and take appropriate remedial actions. Buyer will fully indemnify TI and its representatives against any damages arising out of the use of any TI components in safety-critical applications.

In some cases, TI components may be promoted specifically to facilitate safety-related applications. With such components, TI's goal is to help enable customers to design and create their own end-product solutions that meet applicable functional safety standards and requirements. Nonetheless, such components are subject to these terms.

No TI components are authorized for use in FDA Class III (or similar life-critical medical equipment) unless authorized officers of the parties have executed a special agreement specifically governing such use.

Only those TI components which TI has specifically designated as military grade or "enhanced plastic" are designed and intended for use in military/aerospace applications or environments. Buyer acknowledges and agrees that any military or aerospace use of TI components which have **not** been so designated is solely at the Buyer's risk, and that Buyer is solely responsible for compliance with all legal and regulatory requirements in connection with such use.

TI has specifically designated certain components as meeting ISO/TS16949 requirements, mainly for automotive use. In any case of use of non-designated products, TI will not be responsible for any failure to meet ISO/TS16949.

### Products

Audio	<a href="http://www.ti.com/audio">www.ti.com/audio</a>
Amplifiers	<a href="http://amplifier.ti.com">amplifier.ti.com</a>
Data Converters	<a href="http://dataconverter.ti.com">dataconverter.ti.com</a>
DLP® Products	<a href="http://www.dlp.com">www.dlp.com</a>
DSP	<a href="http://dsp.ti.com">dsp.ti.com</a>
Clocks and Timers	<a href="http://www.ti.com/clocks">www.ti.com/clocks</a>
Interface	<a href="http://interface.ti.com">interface.ti.com</a>
Logic	<a href="http://logic.ti.com">logic.ti.com</a>
Power Mgmt	<a href="http://power.ti.com">power.ti.com</a>
Microcontrollers	<a href="http://microcontroller.ti.com">microcontroller.ti.com</a>
RFID	<a href="http://www.ti-rfid.com">www.ti-rfid.com</a>
OMAP Applications Processors	<a href="http://www.ti.com/omap">www.ti.com/omap</a>
Wireless Connectivity	<a href="http://www.ti.com/wirelessconnectivity">www.ti.com/wirelessconnectivity</a>

### Applications

Automotive and Transportation	<a href="http://www.ti.com/automotive">www.ti.com/automotive</a>
Communications and Telecom	<a href="http://www.ti.com/communications">www.ti.com/communications</a>
Computers and Peripherals	<a href="http://www.ti.com/computers">www.ti.com/computers</a>
Consumer Electronics	<a href="http://www.ti.com/consumer-apps">www.ti.com/consumer-apps</a>
Energy and Lighting	<a href="http://www.ti.com/energy">www.ti.com/energy</a>
Industrial	<a href="http://www.ti.com/industrial">www.ti.com/industrial</a>
Medical	<a href="http://www.ti.com/medical">www.ti.com/medical</a>
Security	<a href="http://www.ti.com/security">www.ti.com/security</a>
Space, Avionics and Defense	<a href="http://www.ti.com/space-avionics-defense">www.ti.com/space-avionics-defense</a>
Video and Imaging	<a href="http://www.ti.com/video">www.ti.com/video</a>

### TI E2E Community

[e2e.ti.com](http://e2e.ti.com)