

LM3658 Dual Source USB/AC Li Chemistry Charger IC for Portable Applications

Check for Samples: [LM3658](#)

FEATURES

- **Integrated Power FETs with Thermal Regulation**
- **Charges from Either an AC Wall Adapter or USB Power Source with Automatic Source Selection**
- **50 mA to 1000 mA Charge Currents Using AC Wall Adapter**
- **Pin-Selectable USB Charge Currents of 100 mA or 500 mA**
- **LDO Mode with 1A of Source Current is Automatically Invoked When the Battery is Absent and the AC Wall Adapter is Connected**
- **Continuous Battery Temperature Monitoring**
- **Built-in Multiple Safety Timers**
- **Charge Status Indication**
- **Continuous Over-current and Temperature Protection**
- **Near-depleted Battery Pre-conditioning**
- **Sleep Mode with Ultra Low Quiescent Current**
- **On-board Kelvin-sensing Achieves $\pm 0.35\%$ Termination Accuracy**
- **Maintenance Mode with Automatic Recharge**
- **Thermally Enhanced 3 mm x 3 mm WSON Package**

APPLICATIONS

- **Smartphones**
- **Digital Still Cameras**
- **PDA's**
- **Hard Drive and Flash-based MP3 Players**
- **USB-powered Devices**

DESCRIPTION

The LM3658 is a single chip charger IC designed for handheld applications. It can safely charge and maintain a single cell Li-Ion/Polymer battery operating from an AC wall adapter or USB power source. Input power source selection of USB/AC is automatic. With both power sources present, the AC power source has priority. Charge current is programmed through an external resistor when operating from an AC wall adapter allowing charge currents from 50 mA to 1000 mA. When the battery is charged using USB power, charge currents of 100 mA or 500 mA are pin-selectable. The termination voltage is controlled to within $\pm 0.35\%$ of 4.2V.

The LM3658 requires few external components and integrates internal power FETs, reverse current protection and current sensing. The internal power FETs are thermally regulated to obtain the most efficient charging rate for a given ambient temperature.

The LM3658 operates in five modes: pre-qualification mode, constant-current mode, constant-voltage mode, top-off mode and maintenance mode. Additionally, the charger IC operates as a linear regulator in "LDO mode", when the AC wall adapter is connected and no battery is present. Optimal battery management is obtained through thermal regulation, battery temperature measurement and multiple safety timers. The LM3658 provides two open-drain outputs for LED status indication or connection to GPIOs.

Typical Application

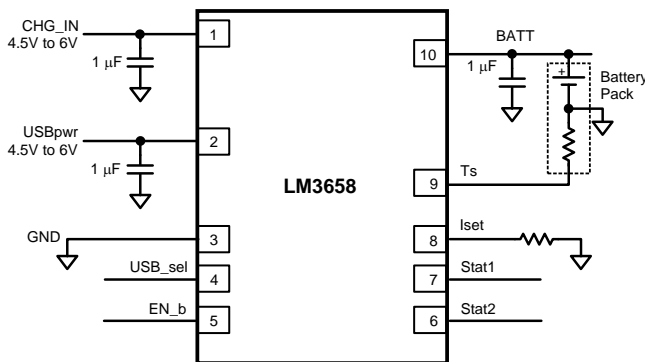

Please be aware that an important notice concerning availability, standard warranty, and use in critical applications of Texas Instruments semiconductor products and disclaimers thereto appears at the end of this data sheet.

All trademarks are the property of their respective owners.

Connection Diagram and Package Mark Information

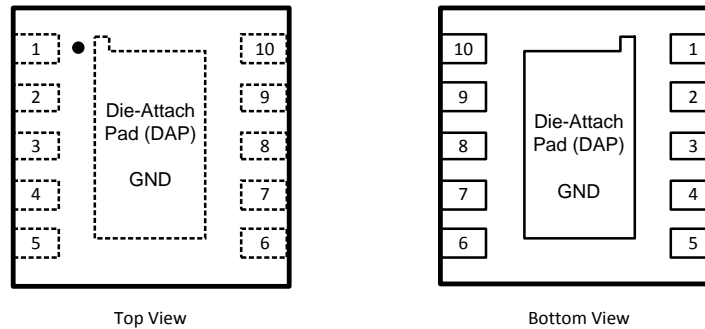

Figure 1. WSON10 Package Drawing

Pin Descriptions

Pin #	Name	Description
1	CHG_IN	AC wall adapter input pin.
2	USBpwr	USB power input pin.
3	GND	Power and signal ground pin.
4	USB_sel	Pulling this pin low limits the USB charge current to 100 mA. Pulling this pin high limits the USB charge current to 500 mA.
5	EN_b	Pulling this pin low enables the charger. Pulling this pin high disables the charger.
6	STAT2	Active low open-drain output. Indicates charger status. This pin is capable of driving an LED as well as GPIOs. See Operation Description section for more detail.
7	STAT1	Active low open-drain output. Indicates charger status. This pin is capable of driving an LED as well as GPIO. See Operation Description section for more detail.
8	I _{SET}	A resistor is connected between this pin and GND. The resistor value determines the full-rate charge current when using the AC source.
9	T _S	Battery temperature sense pin. This pin must be connected to battery pack's temperature sense output pin. For the LM3658SD-B version, leaving this pin open indicates that the battery pack is not present. The charger IC will invoke LDO mode if this pin is left floating. See Operation Description section for more detail.
10	BATT	Positive battery terminal connection.



These devices have limited built-in ESD protection. The leads should be shorted together or the device placed in conductive foam during storage or handling to prevent electrostatic damage to the MOS gates.

ABSOLUTE MAXIMUM RATINGS ⁽¹⁾⁽²⁾⁽³⁾

CHG_IN, USBpwr (V _{CC})		-0.3V to +6.5V
All other pins except GND		-0.3V to CHG_IN or USBpwr
Power Dissipation ⁽⁴⁾		Internally Limited
Junction Temperature (T _{J-MAX})		+150°C
Storage Temperature Range		-65°C to +150°C
ESD Rating ⁽⁵⁾	Human Body Model:	2.0 kV
	Machine Model:	200V

- (1) All voltages are with respect to the potential at the GND pin.
- (2) Absolute Maximum Ratings indicate limits beyond which damage to the component may occur. Operating Ratings are conditions under which operation of the device is specified. Operating Ratings do not imply specified performance limits. For specified performance limits and associated test conditions, see the Electrical Characteristics tables.
- (3) If Military/Aerospace specified devices are required, please contact the Texas Instruments Sales Office/ Distributors for availability and specifications.
- (4) The LM3658 has built-in thermal regulation to regulate the die temperature to 120°C. See [Operation Description](#) section for more detail.
- (5) The Human body model is a 100 pF capacitor discharged through a 1.5 kΩ resistor into each pin. The machine model is a 200 pF capacitor discharged directly into each pin. MIL-STD-883 3015.7

OPERATING RATINGS ⁽¹⁾⁽²⁾

Input Voltage Range for CHG_IN	4.5V to 6.0V
Input Voltage Range for USB_pwr	4.35V to 6.0V
Recommended Load Current	0 to 1000 mA
Power Dissipation ⁽³⁾	Internally Limited
Junction Temperature (T _J) Range	-40°C to +125°C
Ambient Temperature (T _A) Range	-40°C to +85°C

- (1) Absolute Maximum Ratings indicate limits beyond which damage to the component may occur. Operating Ratings are conditions under which operation of the device is specified. Operating Ratings do not imply specified performance limits. For specified performance limits and associated test conditions, see the Electrical Characteristics tables.
- (2) All voltages are with respect to the potential at the GND pin.
- (3) The LM3658 has built-in thermal regulation to regulate the die temperature to 120°C. See [Operation Description](#) section for more detail.

THERMAL PROPERTIES

θ _{JA} , Junction-to-Ambient Thermal Resistance ⁽¹⁾	54°C/W
---	--------

- (1) Junction-to-ambient thermal resistance is highly application and board-layout dependent. In applications where high maximum power dissipation exists, special care must be paid to thermal dissipation issues in board design. Please refer to application note AN-1187 ([SNOA401](#)) for more detail.

ELECTRICAL CHARACTERISTICS

Unless otherwise noted, V_{CC} (V_{CHG_IN} and/or V_{USBpwr}) = 5V, V_{BATT} = 3.5V. C_{CHG_IN} = 1 μF, C_{USBpwr} = 1 μF, C_{BATT} = 1 μF. Typical values and limits appearing in normal type apply for T_J = 25°C. Limits appearing in **boldface** type apply over T_J = 0°C to +85°C. ⁽¹⁾⁽²⁾⁽³⁾

Symbol	Parameter	Conditions	Min	Typ	Max	Units
CHARGER						
V _{CHG_IN}	AC Wall Adapter Input Voltage Range		4.5		6.0	V
V _{USBpwr}	USB Input Voltage Range		4.35		6.0	V
I _{CC_PD}	Quiescent Current in Power Down Mode	V _{BATT} > V _{CC} - V _{OK_CHG}		1	5	μA
I _{CC_STBY}	Quiescent Current in Standby Mode	V _{BATT} < V _{CC} - V _{OK_CHG} V _{CC} > V _{POR} EN_b = High		400	600	μA
I _{BATT_PD}	Battery Leakage Current in Power Down Mode	V _{BATT} > V _{CC} + V _{OK_CHG}		0.01	2.0	μA
I _{BATT_MAINT}	Battery Leakage Current in Maintenance Mode	STAT1 = off, STAT2 = on, adapter or USB connected, V _{BATT} = 4.2V		7	15	μA
V _{OK_CHG}	CHG_IN or USBpwr OK Trip-Point	V _{CC} - V _{BATT} (Rising) V _{CC} - V _{BATT} (Falling)		200 50		mV
V _{POR}	V _{CC} POR Trip-Point	V _{CC} (Rising) V _{BATT} < V _{CC} - V _{OK_CHG} V _{FULL_RATE} < V _{BATT} < V _{TERM}		3.0		V
V _{TERM}	Battery Charge Termination Voltage	I _{CHG} = 10% of its value when V _{BATT} = 3.5V		4.2		V
	Battery Charge Termination Voltage Tolerance	T _A = 25°C	-0.35		+0.35	%
		T _A = 0°C to 85°C	-1.5		+1.5	
V _{CHG_DO}	CHG_IN Drop-Out Voltage	V _{BATT} = V _{TERM} , I _{CHG} = 1A V _{CC} > V _{BATT} + V _{CHG_DO_MAX}		500		mV
V _{USB_DO}	USBpwr Drop-Out Voltage	V _{BATT} = V _{TERM} , USB_sel = high V _{CC} > V _{BATT} + V _{USB_DO_MAX}		250		mV

- (1) All voltages are with respect to the potential at the GND pin.
- (2) Min and Max limits are specified by design, test, or statistical analysis. Typical numbers are not specified, but do represent the most likely norm.
- (3) LM3658 is not intended as a Li-Ion battery protection device; battery used in this application should have an adequate internal protection.

ELECTRICAL CHARACTERISTICS (continued)

Unless otherwise noted, V_{CC} (V_{CHG_IN} and/or V_{USBpwr}) = 5V, $V_{BATT} = 3.5V$. $C_{CHG_IN} = 1 \mu F$, $C_{USBpwr} = 1 \mu F$, $C_{BATT} = 1 \mu F$. Typical values and limits appearing in normal type apply for $T_J = 25^\circ C$. Limits appearing in **boldface** type apply over $T_J = 0^\circ C$ to $+85^\circ C$. ⁽¹⁾⁽²⁾⁽³⁾

Symbol	Parameter	Conditions	Min	Typ	Max	Units
I_{CHG}	CHG_IN Full-Rate Charge Current Range (see full-rate charge mode description)	$6V \geq V_{CC} \geq 4.5V$ $V_{BATT} < V_{CC} - V_{OK_CHG}$ $V_{FULL_RATE} < V_{BATT} < V_{TERM}$ $I_{CHG} = K_{ISET}/R_{ISET}$	50		1000	mA
I_{CHG}	CHG_IN Full Rate Charge Current	$R_{ISET} = 10k\Omega$	220	245	270	mA
		$R_{ISET} = 5 k\Omega$	465	500	535	
		$R_{ISET} = 3.3k\Omega$	700	760	820	
K_{ISET}	Charge Current Set Coefficient $I_{CHG} = K_{ISET}/R_{ISET}$ (see full-rate charge mode description)	$6V \geq V_{CC} \geq 4.5V$ $V_{BATT} < V_{CC} - V_{OK_CHG}$ $V_{FULL_RATE} < V_{BATT} < V_{TERM}$		2500		AQ
V_{ISET}	Charge Current Set Voltage	$6V \geq V_{CC} \geq 4.5V$ $V_{BATT} < V_{CC} - V_{OK_CHG}$ $V_{FULL_RATE} < V_{BATT} < V_{TERM}$		2.5		V
I_{USB_L}	USB Full-Rate Charge Low Current		80	90	100	mA
I_{USB_H}	USB Full-Rate Charge High Current		400	450	500	mA
$I_{PREQUAL}$	Pre-Qualification Current	$V_{BATT} = 2V$, for both AC adapter and USB	35	45	55	mA
V_{FULL_RATE}	Full-Rate Qualification Threshold	V_{BATT} rising, transition from pre-qualification to full-rate charging	2.9	3.0	3.1	V
	Full Rate Hysteresis	V_{BATT} falling	50	60	70	mV
I_{EOC}	End-of-Charge Current, Percent from Full-Range Current	$6V \geq V_{CC} \geq 4.5V$ $V_{BATT} < V_{CC} - V_{OK_CHG}$ $V_{FULL_RATE} < V_{BATT} < V_{TERM}$	7	9	11	%
I_{TOPOFF}	Minimum Top-Off Charge Current	$6V \geq V_{CC} \geq 4.5V$ $V_{BATT} < V_{CC} - V_{OK_CHG}$ $V_{BATT} = V_{TERM}$	1.25	2.5	3.75	%
$V_{RESTART}$	Restart Threshold Voltage	V_{BATT} falling, transition from EOC to pre-qualification mode	3.94	4.0	4.07	V
V_{TL}	Battery Temperature Sense Comparator Low-Voltage Threshold		0.46	0.49	0.52	V
V_{TH}	Battery Temperature Sense Comparator High-Voltage Threshold		2.44	2.49	2.54	V
I_{TSENSE}	Battery Temperature Sense Current		94	100	106	μA
T_{REG}	Regulated Junction Temperature			120		$^\circ C$
T_{SD}	Thermal Shutdown Temperature			165		$^\circ C$
V_{TLDO}	LDO mode detection threshold	TS pin voltage for entry into LDO mode. For LM3658SD-B only	3.95	4.0		v
V_{LDO}	LDO Mode Regulation	$6V \geq V_{CHG_IN} \geq 4.5V$ $T_S = \text{Floating}$ $I_{BATT} = 100mA$	-3.0	4.2	+3.0	%
DETECTION AND TIMING						
T_{POK}	Power OK Deglitch Time	$V_{BATT} < V_{CC} - V_{OK_CHG}$	40	60	100	ms
$T_{PREQUAL}$	Pre-Qualification Timer		27	30	33	mins
T_{PQ_FULL}	Deglitch Time for Pre-Qualification to Full-Rate Charge Transition		270	300	330	ms
T_{FULL_PQ}	Deglitch Time for Full-Rate to Pre-Qualification Transition		270	300	330	ms

ELECTRICAL CHARACTERISTICS (continued)

Unless otherwise noted, V_{CC} (V_{CHG_IN} and/or V_{USBpwr}) = 5V, V_{BATT} = 3.5V. C_{CHG_IN} = 1 μ F, C_{USBpwr} = 1 μ F, C_{BATT} = 1 μ F. Typical values and limits appearing in normal type apply for T_J = 25°C. Limits appearing in **boldface** type apply over T_J = 0°C to +85°C. ⁽¹⁾⁽²⁾⁽³⁾

Symbol	Parameter	Conditions	Min	Typ	Max	Units
T_{CHG}	Charge Timer	LM3658SD, LM3658SD-B and LM3658SD-A with USB_sel=high	270	300	330	mins
		LM3658SD-A with USB_sel=low	540	600	660	
T_{EOC}	Deglintch Time for End-of-Charge Transition		270	300	330	ms
$T_{BATTEMP}$	Deglintch Time for Battery Temperature Fault		20	40	80	ms
T_{DGL}	Deglintch Time for EN_b and USB_sel Pins		20	40	80	ms
$T_{ITOPPOFF}$	Deglintch Time for I_{TOPOFF}		270	300	330	ms
T_{TOPOFF}	Top-Off Charging Timer	LM3658SD, LM3658SD-B and LM3658SD-A with USB_sel=high	27	30	33	mins
		LM3658SD-A with USB_sel=low	54	60	66	
I/O						
V_{IL}	Low-Level Input Voltage	EN_b	0		0.7	V
		USB_sel			1.5	
V_{IH}	High-Level Input Voltage	EN_b	1.4			V
		USB_sel	2.5			
I_{OL}	Low-Level Output Current	STAT1, STAT2, output voltage = 0.25V	10	25		mA
I_{OH}	High-Level Output Current	STAT1, STAT2, output voltage = 6.0V		0.01	1	μ A

BLOCK DIAGRAM

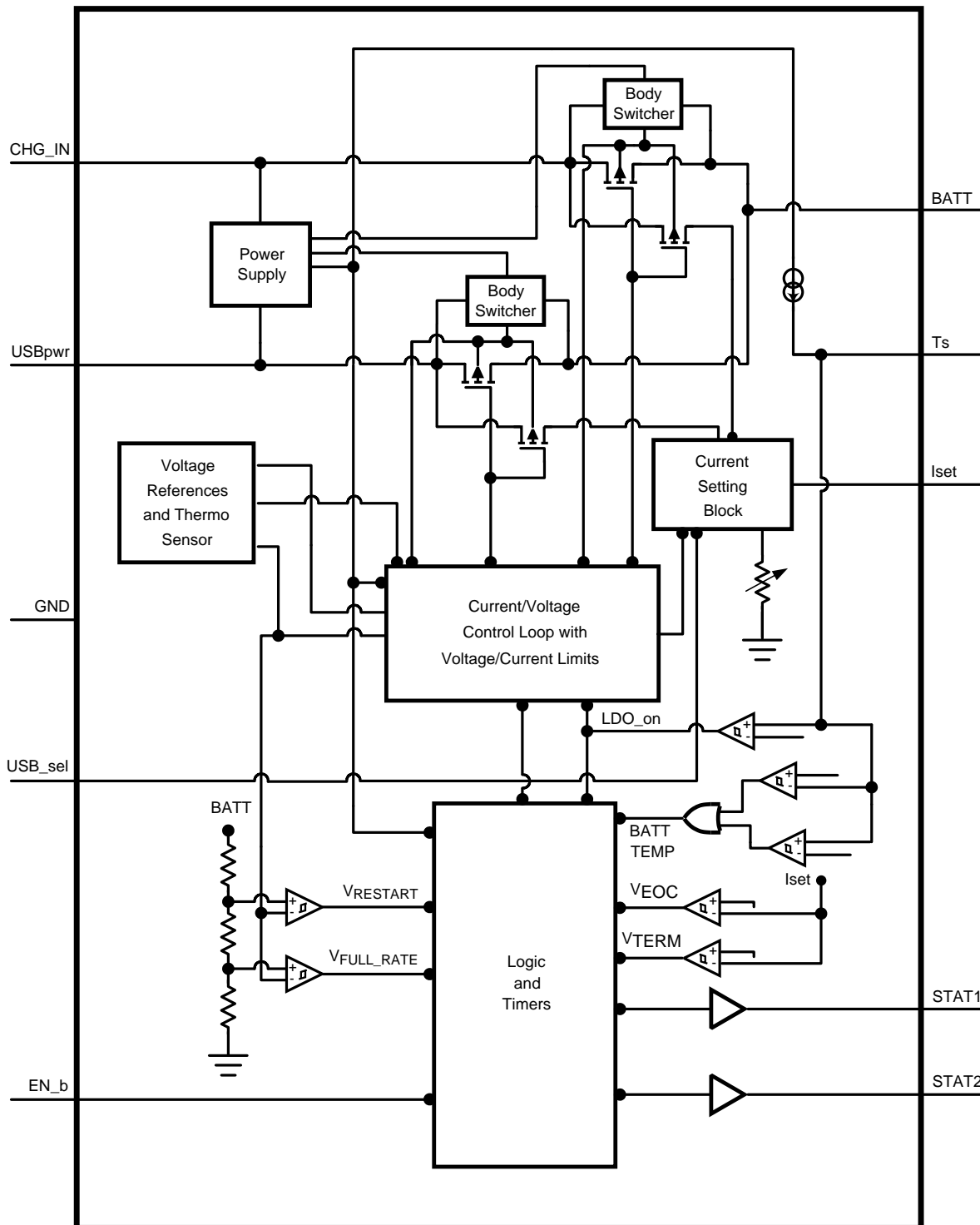

Li-Ion Charging Profile

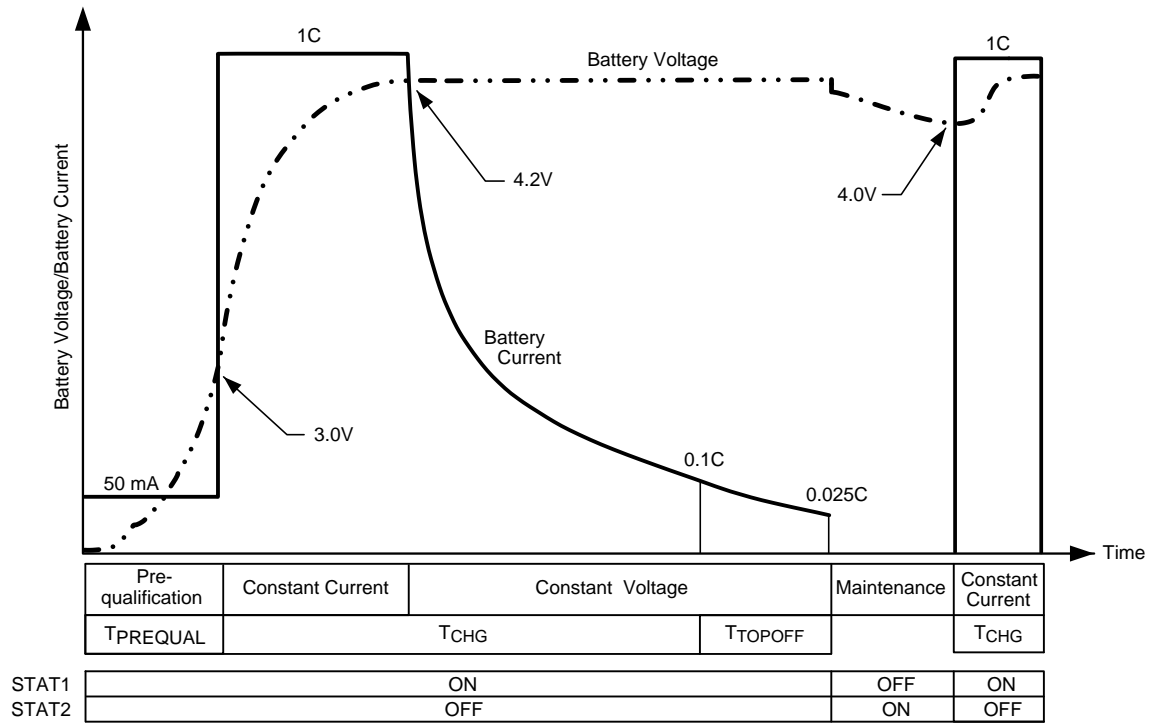

LM3658 OPERATION DESCRIPTION

POWER-DOWN MODE

The LM3658 will power down automatically when the voltage on the USBpwr or CHG_IN pin drops below the battery voltage with an amount that is equal to V_{OK_CHG} ($V_{BATT} > V_{CC} - V_{OK_CHG}$). Power-Down mode shuts off the internal power FETs as well as the open-drain pull-down transistors on the status pins STAT1 and STAT2. The only current consumed by the LM3658 is an ultra-low quiescent current of 1 μ A typical.

POWER-ON RESET

As soon as the voltage of one of the power sources rises above $V_{BATT} + V_{OK_CHG}$, the charger will wake up. However, charging will not be initiated unless the supply voltage source exceeds the V_{POR} .

AUTOMATIC POWER SOURCE DETECTION

When the voltage of one of the power sources exceeds the V_{POR} threshold, the LM3658 detects which power source is a valid charge supply. When both supply voltages are valid and present, CHG_IN will automatically be selected over USBpwr. The USBpwr will be the designated power source only if no CHG_IN is present or when the voltage on the CHG_IN pin is less than the battery voltage.

THERMAL POWER FET REGULATION

The internal power FETs are thermally regulated to the junction temperature of 120°C to specify optimal charging of the battery. At all times is the charge current limited by the I_{SET} resistor setting, the USB 100 mA/500 mA selection, or the 100°C junction temperature of the LM3658. The charge current is therefore a function of the charge current settings, the thermal conductivity of the package and the ambient temperature as described in the following equation:

$$I_{CHG} = \min \left[\frac{K_{ISET}}{R_{ISET}} \text{ or } USB_sel \text{ or } \frac{120^\circ\text{C} - T_A}{\theta_{JA}(V_{CC} - V_{BATT})} \right]$$

Where T_A is the ambient temperature and θ_{JA} is the thermal resistance of the package. Thermal regulation specifies maximum charge current and superior charge rate without exceeding the power dissipation limits of the LM3658.

PRE-QUALIFICATION MODE

During pre-qualification, STAT1 is on and STAT2 is off, and the charger supplies a constant current of 50 mA to the battery. When the battery voltage reaches V_{FULL_RATE} , the charger transitions from pre-qualification to full-rate charging. The pre-qualification mode aborts when the battery doesn't reach V_{FULL_RATE} within the time allowed in $T_{PREQUAL}$ timer. In this event, charging stops and STAT1 and STAT2 will both be on, indicating a bad battery condition.

CHG_IN FULL-RATE CHARGING MODE

The full-rate charge cycle is initiated following the successful completion of the pre-qualification mode. Timer T_{CHG} starts to count when the charger enters full-rate charging, with STAT1 on and STAT2 off. When charging with an AC wall adapter, the full-rate charge current is proportional to the value of the resistor that is connected to the I_{SET} pin as described in the following equation:

$$I_{CHG} = \frac{K_{ISET}}{R_{ISET}}$$

It is recommended to charge Li-Ion batteries at 1C rate, where "C" is the capacity of the battery. As an example, it is recommended to charge a 750 mAh battery at 750 mA, or 1C. Charging at a higher rate can cause damage to the battery.

USBpwr FULL-RATE CHARGING MODE

The full-rate charge cycle is initiated following the successful completion of the pre-qualification mode. Timer T_{CHG} starts to count when the charger enters full-rate charging, with STAT1 on and STAT2 off. If the USB bus provides the charger supply, then the default full-rate charge current is 100 mA max unless the USB_sel pin is pulled high, which sets the charge current to 500 mA max.

CONSTANT-VOLTAGE CHARGING MODE AND END-OF-CHARGE (EOC) DETECTION

The battery voltage increases rapidly as a result of full-rate charging and will reach the 4.2V termination voltage, triggering the constant-voltage charge cycle. Timer T_{CHG} continues to count in this cycle. STAT1 is on and STAT2 is off. The charge current gradually decreases during constant-voltage charging until it reaches the End-Of-Charge (EOC), which is equal to 10% of the full-rate current set either by the resistor connected to the I_{SET} pin or the USB_sel pin. If Timer T_{CHG} times out before EOC is reached, charging stops and STAT1 and STAT2 will both be on, indicating a bad battery condition.

TOP-OFF CHARGING MODE

Once EOC has been reached, a top-off cycle continues to charge the battery. Timed top-off cycle provides optimal battery capacity following a complete charge cycle. During this cycle, charging terminates when I_{CHG} reaches 2.5% of the full-rate charge current or when T_{TOPOFF} times out, whichever occurs first. STAT1 will turn off and STAT2 will turn on once the top-off cycle completes successfully, indicating that charging is done.

MAINTENANCE MODE

Maintenance mode begins immediately after the charger successfully finishes the top-off cycle. In the maintenance mode, the battery voltage is being monitored by the LM3658 continuously. If the battery voltage drops 200 mV below V_{TERM} , a new full-rate charge cycle starts to replenish the battery. As this new full-rate charge cycle begins, STAT1 will turn on and STAT2 will turn off, and all the timers will reset. Refer to the [LM3658 Flowchart](#).

CHARGE STATUS OUTPUTS

The LM3658 provides two open-drain outputs STAT1 and STAT2 that can be connected to external LEDs or to General Purpose I/O's (GPIO) of a peripheral IC. All charge status of the LM3658 is illustrated in [Table 1](#). "ON" means that STATx pin is pulled low as its pull-down transistor is turned on, representing a logic 0.

Table 1. Status Pins Summary

STAT1	STAT2	Condition
OFF	OFF	Power-Down, charging is suspended or interrupted
ON	OFF	Pre-qualification mode, CC and CV charging, Top-off mode
OFF	ON	Charge is completed
ON	ON	Bad battery (Safety timer expired), or LDO mode

SAFETY TIMERS

In order to prevent endless charging of the battery, which can cause damage to the battery, there are three safety timers that forcefully terminate charging if the charging mode is not completed within the time allowed.

Pre-Qualification Timer ($T_{PREQUAL}$)

The pre-qualification timer starts with the initiation of the pre-qualification mode and allows 30 minutes to transition from pre-qualification to full rate charging. If the battery voltage does not reach V_{FULL_RATE} in 30 minutes, charging stops and status pins STAT1 and STAT2 both turn on to indicate a bad battery status.

Charger Timer (T_{CHG})

The charge timer starts with the initiation of full-rate charging and has a duration of 5 hours for the LM3658. If the charge current does not reach EOC, charging stops and STAT1 and STAT2 both turn on to indicate a bad battery status. Once the charge control declares a bad battery, removing the input source is the only means to clear the bad battery status.

Top-Off Timer (T_{TOPOFF})

Once the charger successfully completes constant current constant voltage charging, it enters top-off mode and starts T_{TOPOFF} timer. Topoff lasts 30 minutes for the LM3658. During top-off, charging stops when T_{TOPOFF} reaches its count or when I_{CHG} reaches 2.5% of the full-rate charge current. There is no time-out condition in top-off mode.

When charging is interrupted either by battery temperature out of range or disabling the LM3658, the applicable safety timer will store its count value for the duration of the interruption and subsequently resumes counting from its stored count value when charging continues, only if the charger resumes to the same operation mode it was in before the interrupt.

The LM3658SD-A version has selectable timers for T_{CHG} and T_{TOPOFF} . Based on the logic level applied to the USB_sel pin, timers can be chosen as follow:

Input	USB_SEL	T_{PREQUAL}	T_{CHG}	T_{TOPOFF}
CHG_IN	Low	30 minutes	10 hours	60 minutes
CHG_IN	High	30 minutes	5 hours	30 minutes
USBpwr	Low	30 minutes	10 hours	60 minutes
USBpwr	High	30 minutes	5 hours	30 minutes

BATTERY TEMPERATURE MONITORING (SUSPEND MODE)

The LM3658 is equipped with a battery thermistor interface to continuously monitor the battery temperature by measuring the voltage between the T_S pin and ground. Charging is allowed only if the battery temperature is within the acceptable temperature range set by a pair of internal comparators inside the LM3658. If the battery temperature is out of range, STAT1 and STAT2 both turn off and charging is suspended. Timer holds its count value.

The T_S pin is only active during charging and draws no current from the battery when no external power source is present.

If the T_S pin is not used in the application, it should be connected to GND through 10k Ω pulldown resistor.

When the T_S pin is left floating (battery removal), then the charger will be disabled as the T_S voltage exceeds the upper temperature limit.

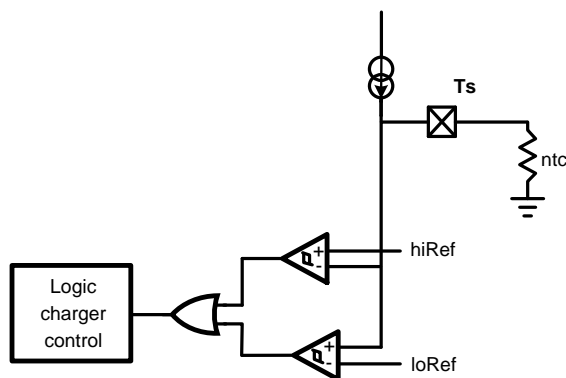

The LM3658 battery temperature feature is tailored to use negative temperature coefficient (NTC) 103AT thermistors with 10k Ω impedance. If alternative thermistors need to be used in the system, supplemental external resistors are needed to create a circuit with equivalent impedance.

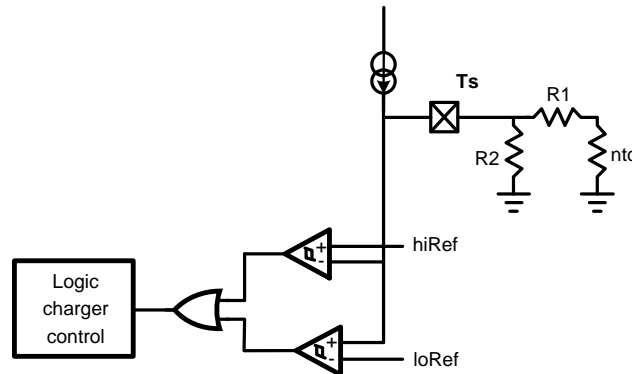

DISABLING CHARGER (CHARGE INTERRUPT MODE)

Charging can be safely interrupted by pulling the EN_b pin high and charging can resume upon pulling the EN_b pin low. The enable pin can be permanently tied to GND with no extra current consumption penalty during power down mode. When the charger is disabled, timer holds its count value, and STAT1 and STAT2 are both off.

LDO MODE (AVAILABLE ONLY IN LM3658SD-B VERSION)

The LM3658SD-B version enters LDO mode when the T_s pin is floating and AC wall adapter is still connected to CHG_IN pin. In LDO mode, STAT1 and STAT2 are both on. The LM3658SD-B becomes a linear regulator capable of delivering 1A of source current. Normally the T_s pin is connected to the thermistor from the battery pack for temperature monitoring purpose. If this pin is disconnected, the LM3658SD-B assumes that there is no battery present and will automatically invoke the LDO mode. LDO mode allows applications to operate without a battery provided that the AC wall adapter supplies power to the CHG_IN pin. The LDO mode is not possible in USB mode.

For the other versions of the LM3658, floating the T_s pin does not invoke LDO mode. Instead, it will go to suspend mode. Please refer to “[Battery Temperature Monitoring](#)” section for more detail.

5 HOUR/ 10 HOUR SELECTABLE TIMER (AVAILABLE ONLY IN LM3658SD-A VERSION)

The LM3658SD-A allows the user to select between 5 hour or 10 hour timer based on the polarity of the USB_sel pin, in both CHG_IN mode and USBpwr mode. By pulling the USB_sel pin high, the timer is set to 5 hours. In the USBpwr mode, the polarity of the USB_sel pin determines the charge current as well as the timer. In CHG_IN mode, the polarity of the USB_sel pin determines only the timer. The charge current is set by the resistor at I_{set} pin.

INPUT/OUTPUT BYPASS CAPACITORS

Care should be taken to support the stability of the charge system by connecting a 1 μ F capacitor as close as possible to the BATT pin. An input capacitor ranging from 1.0 μ F– 10.0 μ F must be connected to the CHG_IN and USBpwr input pins. Low cost ceramic capacitors can be selected.

THERMAL PERFORMANCE OF THE WSON PACKAGE

The LM3658 is a monolithic device with integrated power FETs. For that reason, it is important to pay special attention to the thermal impedance of the WSON package and to the PCB layout rules in order to maximize power dissipation of the WSON package.

The WSON package is designed for enhanced thermal performance and features an exposed die attach pad at the bottom center of the package that creates a direct path to the PCB for maximum power dissipation. Compared to the traditional leaded packages where the die attach pad is embedded inside the molding compound, the WSON reduces one layer in the thermal path.

The thermal advantage of the WSON package is fully realized only when the exposed die attach pad is soldered down to a thermal land on the PCB board with thermal vias planted underneath the thermal land. Based on thermal analysis of the WSON package, the junction-to-ambient thermal resistance (θ_{JA}) can be improved by a factor of two when the die attach pad of the WSON package is soldered directly onto the PCB with thermal land and thermal vias, as opposed to an alternative with no direct soldering to a thermal land. Typical pitch and outer diameter for thermal vias are 1.27 mm and 0.33 mm respectively. Typical copper via barrel plating is 1 oz, although thicker copper may be used to further improve thermal performance. The LM3658 die attach pad is connected to the substrate of the IC and therefore, the thermal land and vias on the PCB board need to be connected to ground (GND pin).

For more information on board layout techniques, refer to Application Note 1187 ([SNOA401](#)) “Leadless Lead Frame Package (LLP).” This application note also discusses package handling, solder stencil and the assembly process.

LM3658 FLOWCHARTS

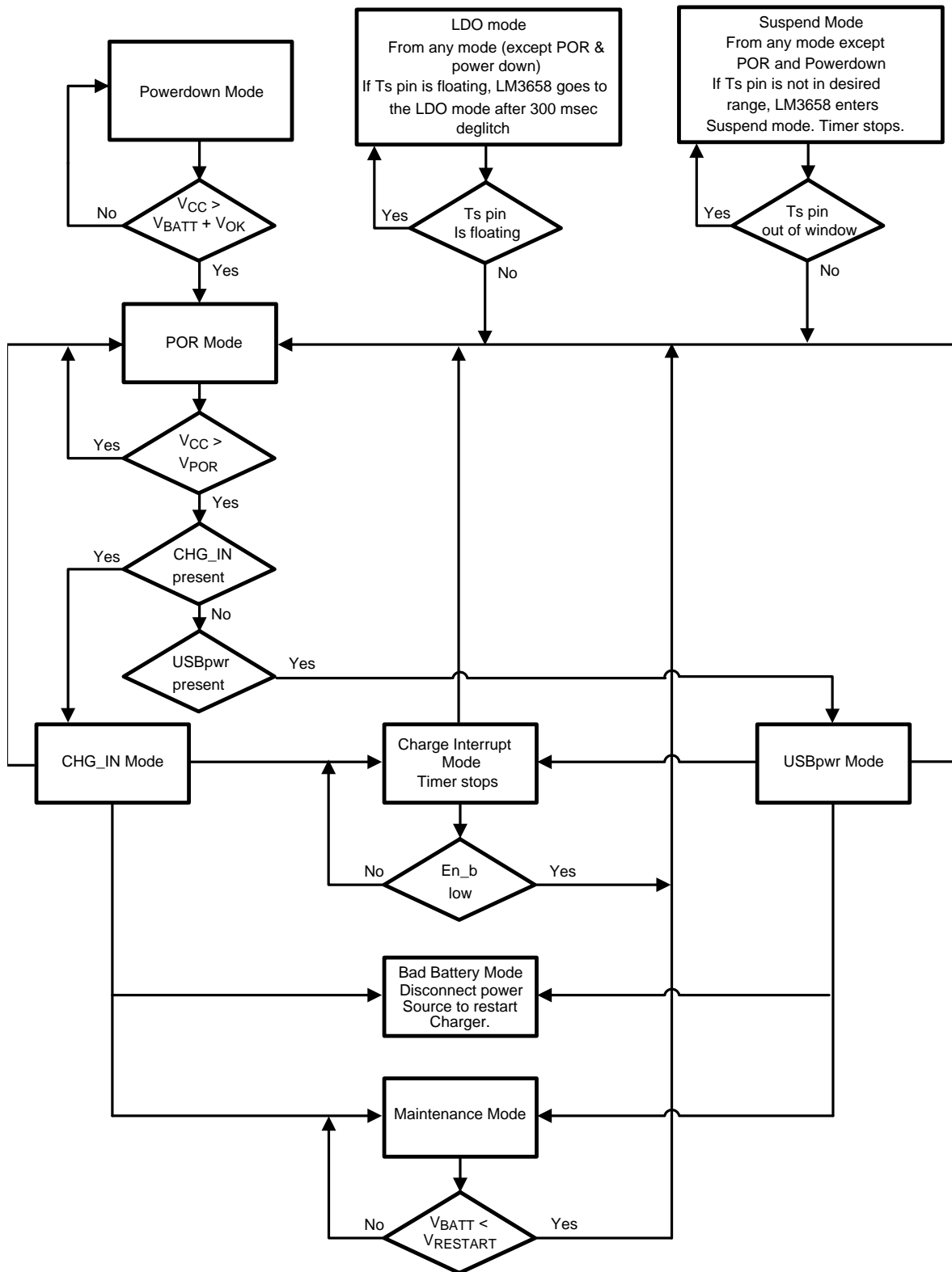

Figure 2. LM3658 Flowchart

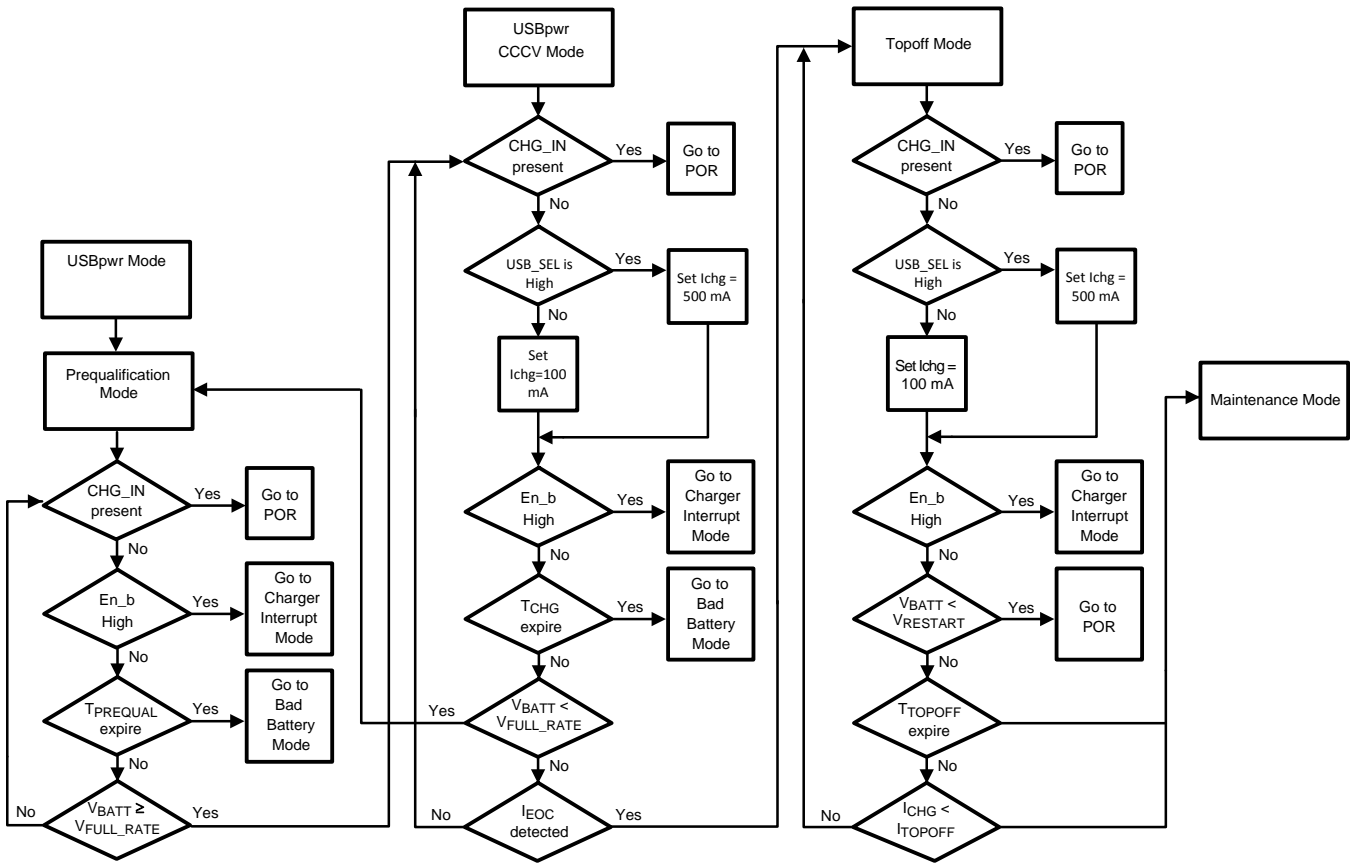

Figure 3. LM3658 USBpwr Mode Flowchart

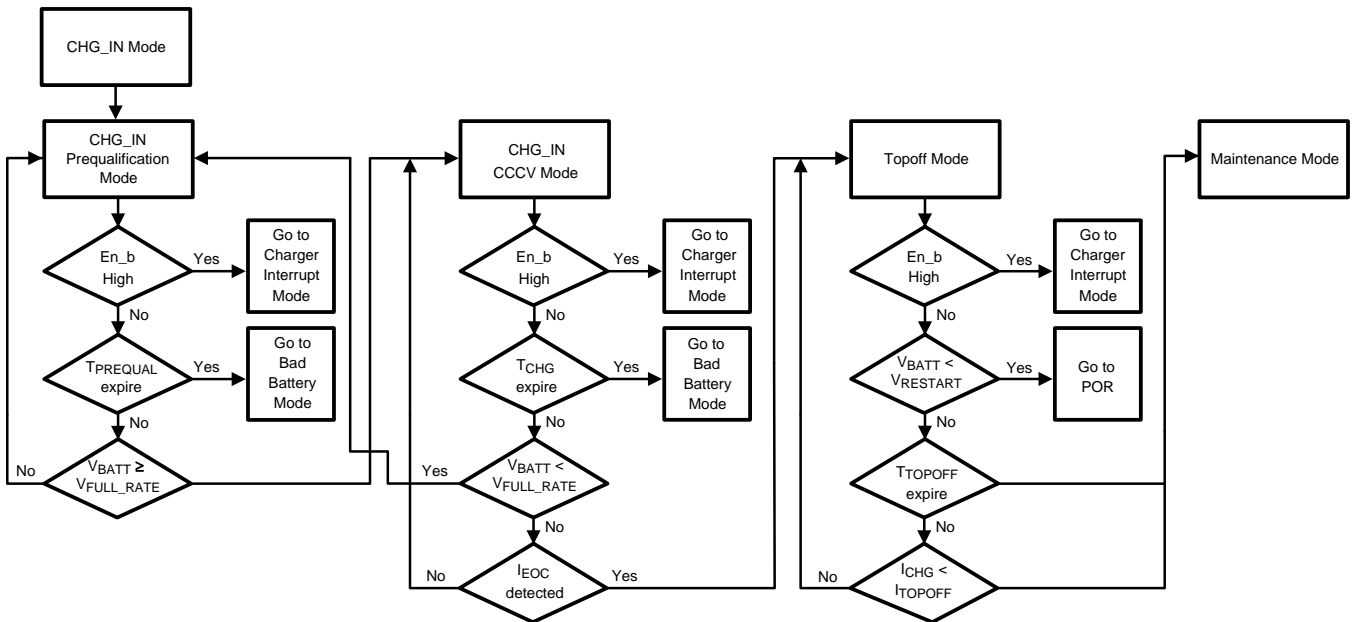

Figure 4. LM3658 CHG_IN Mode Flowchart

PACKAGING INFORMATION

Orderable Device	Status (1)	Package Type	Package Drawing	Pins	Package Qty	Eco Plan (2)	Lead/Ball Finish (6)	MSL Peak Temp (3)	Op Temp (°C)	Device Marking (4/5)	Samples
LM3658SD	NRND	WSON	DSC	10	1000	TBD	Call TI	Call TI	-40 to 85	L111B	
LM3658SD-A/NOPB	ACTIVE	WSON	DSC	10	1000	Green (RoHS & no Sb/Br)	CU SN	Level-1-260C-UNLIM	-40 to 85	L155B	Samples
LM3658SD-B/NOPB	ACTIVE	WSON	DSC	10	1000	Green (RoHS & no Sb/Br)	CU SN	Level-1-260C-UNLIM	-40 to 85	L156B	Samples
LM3658SD/NOPB	ACTIVE	WSON	DSC	10	1000	Green (RoHS & no Sb/Br)	CU SN	Level-1-260C-UNLIM	-40 to 85	L111B	Samples
LM3658SDX-A/NOPB	ACTIVE	WSON	DSC	10	4500	Green (RoHS & no Sb/Br)	CU SN	Level-1-260C-UNLIM	-40 to 85	L155B	Samples
LM3658SDX-B/NOPB	ACTIVE	WSON	DSC	10	4500	Green (RoHS & no Sb/Br)	CU SN	Level-1-260C-UNLIM	-40 to 85	L156B	Samples
LM3658SDX/NOPB	ACTIVE	WSON	DSC	10	4500	Green (RoHS & no Sb/Br)	CU SN	Level-1-260C-UNLIM	-40 to 85	L111B	Samples

(1) The marketing status values are defined as follows:

ACTIVE: Product device recommended for new designs.

LIFEBUY: TI has announced that the device will be discontinued, and a lifetime-buy period is in effect.

NRND: Not recommended for new designs. Device is in production to support existing customers, but TI does not recommend using this part in a new design.

PREVIEW: Device has been announced but is not in production. Samples may or may not be available.

OBSELETE: TI has discontinued the production of the device.

(2) Eco Plan - The planned eco-friendly classification: Pb-Free (RoHS), Pb-Free (RoHS Exempt), or Green (RoHS & no Sb/Br) - please check <http://www.ti.com/productcontent> for the latest availability information and additional product content details.

TBD: The Pb-Free/Green conversion plan has not been defined.

Pb-Free (RoHS): TI's terms "Lead-Free" or "Pb-Free" mean semiconductor products that are compatible with the current RoHS requirements for all 6 substances, including the requirement that lead not exceed 0.1% by weight in homogeneous materials. Where designed to be soldered at high temperatures, TI Pb-Free products are suitable for use in specified lead-free processes.

Pb-Free (RoHS Exempt): This component has a RoHS exemption for either 1) lead-based flip-chip solder bumps used between the die and package, or 2) lead-based die adhesive used between the die and leadframe. The component is otherwise considered Pb-Free (RoHS compatible) as defined above.

Green (RoHS & no Sb/Br): TI defines "Green" to mean Pb-Free (RoHS compatible), and free of Bromine (Br) and Antimony (Sb) based flame retardants (Br or Sb do not exceed 0.1% by weight in homogeneous material)

(3) MSL, Peak Temp. - The Moisture Sensitivity Level rating according to the JEDEC industry standard classifications, and peak solder temperature.

(4) There may be additional marking, which relates to the logo, the lot trace code information, or the environmental category on the device.

⁽⁵⁾ Multiple Device Markings will be inside parentheses. Only one Device Marking contained in parentheses and separated by a "-" will appear on a device. If a line is indented then it is a continuation of the previous line and the two combined represent the entire Device Marking for that device.

⁽⁶⁾ Lead/Ball Finish - Orderable Devices may have multiple material finish options. Finish options are separated by a vertical ruled line. Lead/Ball Finish values may wrap to two lines if the finish value exceeds the maximum column width.

Important Information and Disclaimer:The information provided on this page represents TI's knowledge and belief as of the date that it is provided. TI bases its knowledge and belief on information provided by third parties, and makes no representation or warranty as to the accuracy of such information. Efforts are underway to better integrate information from third parties. TI has taken and continues to take reasonable steps to provide representative and accurate information but may not have conducted destructive testing or chemical analysis on incoming materials and chemicals. TI and TI suppliers consider certain information to be proprietary, and thus CAS numbers and other limited information may not be available for release.

In no event shall TI's liability arising out of such information exceed the total purchase price of the TI part(s) at issue in this document sold by TI to Customer on an annual basis.

TAPE AND REEL INFORMATION

QUADRANT ASSIGNMENTS FOR PIN 1 ORIENTATION IN TAPE

*All dimensions are nominal

Device	Package Type	Package Drawing	Pins	SPQ	Reel Diameter (mm)	Reel Width W1 (mm)	A0 (mm)	B0 (mm)	K0 (mm)	P1 (mm)	W (mm)	Pin1 Quadrant
LM3658SD	WSON	DSC	10	1000	178.0	12.4	3.3	3.3	1.0	8.0	12.0	Q1
LM3658SD-A/NOPB	WSON	DSC	10	1000	178.0	12.4	3.3	3.3	1.0	8.0	12.0	Q1
LM3658SD-B/NOPB	WSON	DSC	10	1000	178.0	12.4	3.3	3.3	1.0	8.0	12.0	Q1
LM3658SD/NOPB	WSON	DSC	10	1000	178.0	12.4	3.3	3.3	1.0	8.0	12.0	Q1
LM3658SDX-A/NOPB	WSON	DSC	10	4500	330.0	12.4	3.3	3.3	1.0	8.0	12.0	Q1
LM3658SDX-B/NOPB	WSON	DSC	10	4500	330.0	12.4	3.3	3.3	1.0	8.0	12.0	Q1
LM3658SDX/NOPB	WSON	DSC	10	4500	330.0	12.4	3.3	3.3	1.0	8.0	12.0	Q1

TAPE AND REEL BOX DIMENSIONS

*All dimensions are nominal

Device	Package Type	Package Drawing	Pins	SPQ	Length (mm)	Width (mm)	Height (mm)
LM3658SD	WSON	DSC	10	1000	210.0	185.0	35.0
LM3658SD-A/NOPB	WSON	DSC	10	1000	210.0	185.0	35.0
LM3658SD-B/NOPB	WSON	DSC	10	1000	210.0	185.0	35.0
LM3658SD/NOPB	WSON	DSC	10	1000	210.0	185.0	35.0
LM3658SDX-A/NOPB	WSON	DSC	10	4500	367.0	367.0	35.0
LM3658SDX-B/NOPB	WSON	DSC	10	4500	367.0	367.0	35.0
LM3658SDX/NOPB	WSON	DSC	10	4500	367.0	367.0	35.0

IMPORTANT NOTICE

Texas Instruments Incorporated and its subsidiaries (TI) reserve the right to make corrections, enhancements, improvements and other changes to its semiconductor products and services per JESD46, latest issue, and to discontinue any product or service per JESD48, latest issue. Buyers should obtain the latest relevant information before placing orders and should verify that such information is current and complete. All semiconductor products (also referred to herein as "components") are sold subject to TI's terms and conditions of sale supplied at the time of order acknowledgment.

TI warrants performance of its components to the specifications applicable at the time of sale, in accordance with the warranty in TI's terms and conditions of sale of semiconductor products. Testing and other quality control techniques are used to the extent TI deems necessary to support this warranty. Except where mandated by applicable law, testing of all parameters of each component is not necessarily performed.

TI assumes no liability for applications assistance or the design of Buyers' products. Buyers are responsible for their products and applications using TI components. To minimize the risks associated with Buyers' products and applications, Buyers should provide adequate design and operating safeguards.

TI does not warrant or represent that any license, either express or implied, is granted under any patent right, copyright, mask work right, or other intellectual property right relating to any combination, machine, or process in which TI components or services are used. Information published by TI regarding third-party products or services does not constitute a license to use such products or services or a warranty or endorsement thereof. Use of such information may require a license from a third party under the patents or other intellectual property of the third party, or a license from TI under the patents or other intellectual property of TI.

Reproduction of significant portions of TI information in TI data books or data sheets is permissible only if reproduction is without alteration and is accompanied by all associated warranties, conditions, limitations, and notices. TI is not responsible or liable for such altered documentation. Information of third parties may be subject to additional restrictions.

Resale of TI components or services with statements different from or beyond the parameters stated by TI for that component or service voids all express and any implied warranties for the associated TI component or service and is an unfair and deceptive business practice. TI is not responsible or liable for any such statements.

Buyer acknowledges and agrees that it is solely responsible for compliance with all legal, regulatory and safety-related requirements concerning its products, and any use of TI components in its applications, notwithstanding any applications-related information or support that may be provided by TI. Buyer represents and agrees that it has all the necessary expertise to create and implement safeguards which anticipate dangerous consequences of failures, monitor failures and their consequences, lessen the likelihood of failures that might cause harm and take appropriate remedial actions. Buyer will fully indemnify TI and its representatives against any damages arising out of the use of any TI components in safety-critical applications.

In some cases, TI components may be promoted specifically to facilitate safety-related applications. With such components, TI's goal is to help enable customers to design and create their own end-product solutions that meet applicable functional safety standards and requirements. Nonetheless, such components are subject to these terms.

No TI components are authorized for use in FDA Class III (or similar life-critical medical equipment) unless authorized officers of the parties have executed a special agreement specifically governing such use.

Only those TI components which TI has specifically designated as military grade or "enhanced plastic" are designed and intended for use in military/aerospace applications or environments. Buyer acknowledges and agrees that any military or aerospace use of TI components which have **not** been so designated is solely at the Buyer's risk, and that Buyer is solely responsible for compliance with all legal and regulatory requirements in connection with such use.

TI has specifically designated certain components as meeting ISO/TS16949 requirements, mainly for automotive use. In any case of use of non-designated products, TI will not be responsible for any failure to meet ISO/TS16949.

Products

Audio	www.ti.com/audio
Amplifiers	amplifier.ti.com
Data Converters	dataconverter.ti.com
DLP® Products	www.dlp.com
DSP	dsp.ti.com
Clocks and Timers	www.ti.com/clocks
Interface	interface.ti.com
Logic	logic.ti.com
Power Mgmt	power.ti.com
Microcontrollers	microcontroller.ti.com
RFID	www.ti-rfid.com
OMAP Applications Processors	www.ti.com/omap
Wireless Connectivity	www.ti.com/wirelessconnectivity

Applications

Automotive and Transportation	www.ti.com/automotive
Communications and Telecom	www.ti.com/communications
Computers and Peripherals	www.ti.com/computers
Consumer Electronics	www.ti.com/consumer-apps
Energy and Lighting	www.ti.com/energy
Industrial	www.ti.com/industrial
Medical	www.ti.com/medical
Security	www.ti.com/security
Space, Avionics and Defense	www.ti.com/space-avionics-defense
Video and Imaging	www.ti.com/video

TI E2E Community

e2e.ti.com