

FEATURES

- Output Voltage Range Adjustable From -1.2 V to -37 V
- Output Current Capability of 1.5 A Max
- Input Regulation Typically 0.01% Per Input-Voltage Change
- Output Regulation Typically 0.3%
- Peak Output Current Constant Over Temperature Range of Regulator
- Ripple Rejection Typically 77 dB
- Direct Replacement for Industry-Standard LM237 and LM337

LM237, LM337...KC (TO-220) PACKAGE
(TOP VIEW)

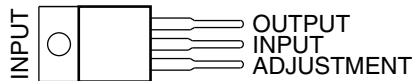

LM337...KCS (TO-220) PACKAGE
(TOP VIEW)

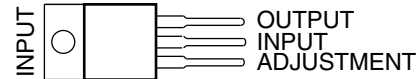

LM337...KTE, KTP, OR KVV PACKAGE
(TOP VIEW)

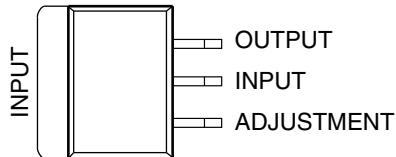

LM337...KTT (TO-263) PACKAGE
(TOP VIEW)

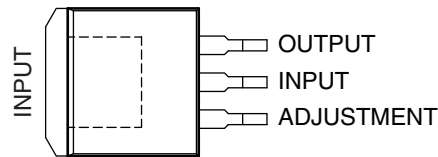

DESCRIPTION/ORDERING INFORMATION

The LM237 and LM337 are adjustable 3-terminal negative-voltage regulators capable of supplying in excess of -1.5 A over an output voltage range of -1.2 V to -37 V . They are exceptionally easy to use, requiring only two external resistors to set the output voltage and one output capacitor for frequency compensation. The current design has been optimized for excellent regulation and low thermal transients. In addition, the LM237 and LM337 feature internal current limiting, thermal shutdown, and safe-area compensation, making them virtually immune to failure by overloads.

The LM237 and LM337 serve a wide variety of applications, including local on-card regulation, programmable output-voltage regulation, and precision current regulation.

ORDERING INFORMATION

T_J	PACKAGE ⁽¹⁾		ORDERABLE PART NUMBER	TOP-SIDE MARKING
-25°C to 150°C	TO-220 – KC	Tube of 50	LM237KC	LM237
0°C to 125°C	PowerFLEX™ – KTE	Reel of 2000	LM337KTER	LM337
	PowerFLEX – KTP	Reel of 3000	LM337KTPR	L337
	TO-220 – KC	Tube of 50	LM337KC	LM337
	TO-220 – KCS	Tube of 50	LM337KCSE3	LM337
	TO-252 – KVV	Reel of 2500	LM337KVURG3	LM337
	TO-263 – KTT	Reel of 500	LM337KTTR	LM337

(1) Package drawings, standard packing quantities, thermal data, symbolization, and PCB design guidelines are available at www.ti.com/sc/package.



Please be aware that an important notice concerning availability, standard warranty, and use in critical applications of Texas Instruments semiconductor products and disclaimers thereto appears at the end of this data sheet.

PowerFLEX is a trademark of Texas Instruments.

LM237, LM337 3-TERMINAL ADJUSTABLE REGULATORS

SLVS047J–NOVEMBER 1981–REVISED MAY 2007

SCHEMATIC DIAGRAM

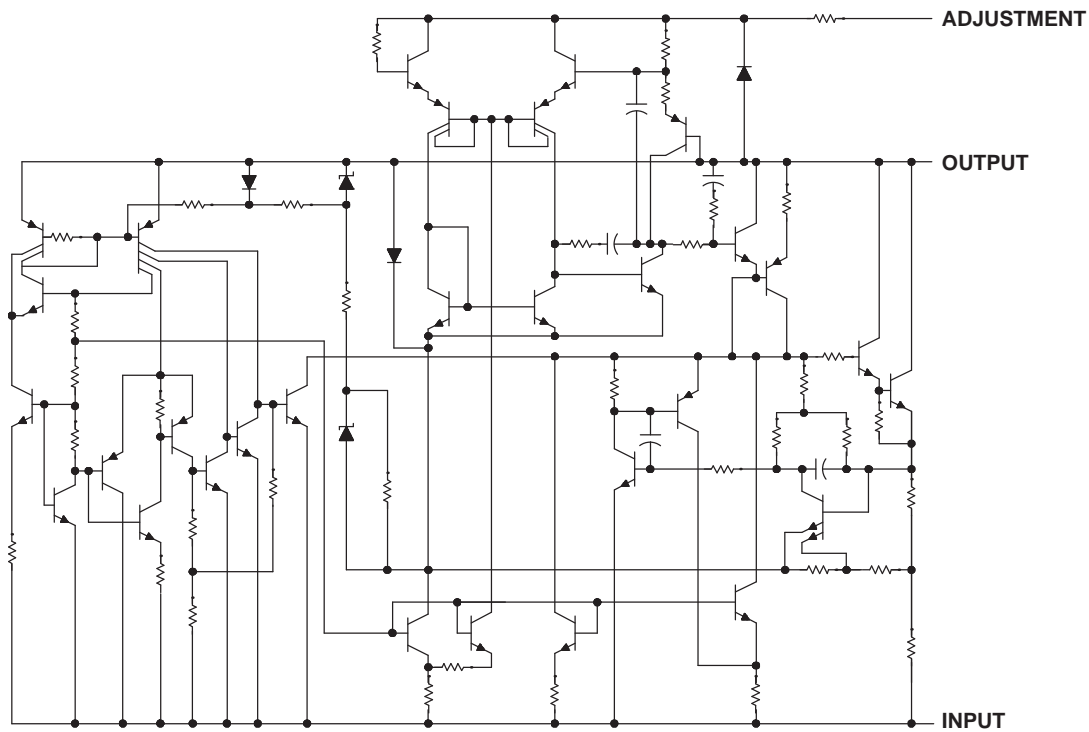

Absolute Maximum Ratings⁽¹⁾

over operating temperature ranges (unless otherwise noted)

	MIN	MAX	UNIT
$V_I - V_O$ Input-to-output differential voltage		-40	V
T_J Operating virtual junction temperature		150	°C
Lead temperature		260	°C
		1,6 mm (1/16 in) from case for 10 s	
T_{stg} Storage temperature range	-65	150	°C

(1) Stresses beyond those listed under "absolute maximum ratings" may cause permanent damage to the device. These are stress ratings only, and functional operation of the device at these or any other conditions beyond those indicated under "recommended operating conditions" is not implied. Exposure to absolute-maximum-rated conditions for extended periods may affect device reliability.

Package Thermal Data⁽¹⁾

PACKAGE	BOARD	θ_{JC}	θ_{JA}
PowerFLEX (KTE)	High K, JESD 51-5	3°C/W	23°C/W
PowerFLEX (KTP)	High K, JESD 51-5	19°C/W	28°C/W
TO-220 (KC)	High K, JESD 51-5	3°C/W	19°C/W
TO-220 (KCS)	High K, JESD 51-5	3°C/W	24.8°C/W
TO-252 (KVU)	High K, JESD 51-5		30.3°C/W
TO-263 (KTT)	High K, JESD 51-5	18°C/W	25.3°C/W

(1) Maximum power dissipation is a function of $T_J(\max)$, θ_{JA} , and T_A . The maximum allowable power dissipation at any allowable ambient temperature is $P_D = (T_J(\max) - T_A)/\theta_{JA}$. Operating at the absolute maximum T_J of 150°C can affect reliability.

Recommended Operating Conditions

			MIN	MAX	UNIT
I_O	Output current	$ V_I - V_O \leq 40 \text{ V}, P \leq 15 \text{ W}$	10	1500	mA
		$ V_I - V_O \leq 10 \text{ V}, P \leq 15 \text{ W}$	6	1500	
T_J	Operating virtual junction temperature	LM237	-25	150	°C
		LM337	0	125	

Electrical Characteristics

over recommended ranges of operating virtual junction temperature (unless otherwise noted)

PARAMETER	TEST CONDITIONS ⁽¹⁾		LM237			LM337			UNIT
			MIN	TYP	MAX	MIN	TYP	MAX	
Input regulation ⁽²⁾	$V_I - V_O = -3 \text{ V to } -40 \text{ V}$	$T_J = 25^\circ\text{C}$	0.01	0.02		0.01	0.04	%V	
		$T_J = \text{MIN to MAX}$	0.02	0.05		0.02	0.07		
Ripple rejection	$V_O = -10 \text{ V}, f = 120 \text{ Hz}$		60			60			dB
	$V_O = -10 \text{ V}, f = 120 \text{ Hz}, C_{\text{ADJ}} = 10 \mu\text{F}$		66	77		66	77		
Output regulation	$I_O = 10 \text{ mA to } 1.5 \text{ A}, T_J = 25^\circ\text{C}$	$ V_O \leq 5 \text{ V}$	25			50			mV
		$ V_O \geq 5 \text{ V}$	0.3	0.5		0.3	1	%	
	$I_O = 10 \text{ mA to } 1.5 \text{ A}$	$ V_O \leq 5 \text{ V}$	50			70			mV
		$ V_O \geq 5 \text{ V}$	1			1.5			%
Output-voltage change with temperature	$T_J = \text{MIN to MAX}$		0.6			0.6			%
Output-voltage long-term drift	After 1000 h at $T_J = \text{MAX}$ and $V_I - V_O = -40 \text{ V}$		0.3	1		0.3	1	%	
Output noise voltage	$f = 10 \text{ Hz to } 10 \text{ kHz}, T_J = 25^\circ\text{C}$		0.003			0.003			%
Minimum output current to maintain regulation	$ V_I - V_O \leq 40 \text{ V}$		2.5	5		2.5	10	mA	
	$ V_I - V_O \leq 10 \text{ V}$		1.2	3		1.5	6		
Peak output current	$ V_I - V_O \leq 15 \text{ V}$		1.5	2.2		1.5	2.2	A	
	$ V_I - V_O \leq 40 \text{ V}, T_J = 25^\circ\text{C}$		0.24	0.4		0.15	0.4		
ADJUSTMENT current			65	100		65	100	μA	
Change in ADJUSTMENT current	$V_I - V_O = -2.5 \text{ V to } -40 \text{ V}, I_O = 10 \text{ mA to MAX}, T_J = 25^\circ\text{C}$		2	5		2	5	μA	
Reference voltage (OUTPUT to ADJUSTMENT)	$V_I - V_O = -3 \text{ V to } -40 \text{ V}, I_O = 10 \text{ mA to } 1.5 \text{ A}, P \leq \text{rated dissipation}$	$T_J = 25^\circ\text{C}$	-1.225	-1.25	-1.275	-1.213	-1.25	-1.287	V
		$T_J = \text{MIN to MAX}$	-1.2	-1.25	-1.3	-1.2	-1.25	-1.3	
Thermal regulation	Initial $T_J = 25^\circ\text{C}$, 10-ms pulse		0.002	0.02		0.003	0.04	%/W	

- (1) Unless otherwise noted, the following test conditions apply: $|V_I - V_O| = 5 \text{ V}$ and $I_O = 0.5 \text{ A}$. For conditions shown as MIN or MAX, use the appropriate value specified under recommended operating conditions. All characteristics are measured with a 0.1- μF capacitor across the input and a 1- μF capacitor across the output. Pulse-testing techniques are used to maintain the junction temperature as close to the ambient temperature as possible. Thermal effects must be taken into account separately.
- (2) Input regulation is expressed here as the percentage change in output voltage per 1-V change at the input.

LM237, LM337

3-TERMINAL ADJUSTABLE REGULATORS

SLVS047J–NOVEMBER 1981–REVISED MAY 2007

Electrical Characteristics

$T_J = 25^\circ\text{C}$

PARAMETER	TEST CONDITIONS ⁽¹⁾	LM237, LM337			UNIT
		MIN	TYP	MAX	
Input regulation ⁽²⁾	$V_I - V_O = -3\text{ V to }-40\text{ V}$		0.01	0.04	%/V
Ripple rejection	$V_O = -10\text{ V}, f = 120\text{ Hz}$		60		dB
	$V_O = -10\text{ V}, f = 120\text{ Hz}, C_{\text{ADJ}} = 10\ \mu\text{F}$		66	77	
Output regulation	$I_O = 10\text{ mA to }1.5\text{ A}$	$ V_O \leq 5\text{ V}$		50	mV
		$ V_O \geq 5\text{ V}$	0.3	1	%
Output noise voltage	$f = 10\text{ Hz to }10\text{ kHz}$		0.003		%
Minimum output current to maintain regulation	$ V_I - V_O \leq 40\text{ V}$		2.5	10	mA
	$ V_I - V_O \leq 10\text{ V}$		1.5	6	
Peak output current	$ V_I - V_O \leq 15\text{ V}$	1.5	2.2		A
	$ V_I - V_O \leq 40\text{ V}$	0.15	0.4		
ADJUSTMENT current			65	100	μA
Change in ADJUSTMENT current	$V_I - V_O = -2.5\text{ V to }-40\text{ V}, I_O = 10\text{ mA to MAX}$		2	5	μA
Reference voltage (OUTPUT to ADJUSTMENT)	$V_I - V_O = -3\text{ V to }-40\text{ V}, I_O = 10\text{ mA to }1.5\text{ A}, P \leq \text{rated dissipation}$	-1.213	-1.25	-1.287	V

- (1) Unless otherwise noted, the following test conditions apply: $|V_I - V_O| = 5\text{ V}$ and $I_O = 0.5\text{ A}$. All characteristics are measured with a $0.1\text{-}\mu\text{F}$ capacitor across the input and a $1\text{-}\mu\text{F}$ capacitor across the output. Pulse-testing techniques are used to maintain the junction temperature as close to the ambient temperature as possible. Thermal effects must be taken into account separately.
- (2) Input regulation is expressed here as the percentage change in output voltage per 1-V change at the input.

APPLICATION INFORMATION

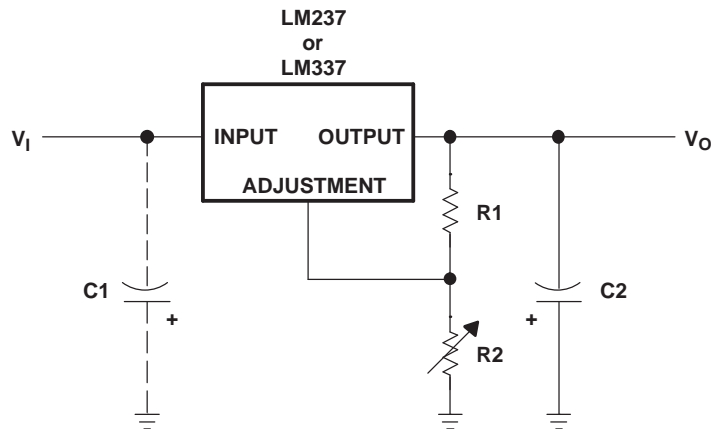

R1 typically is 120 Ω.

$$R2 = R1 \left(\frac{-V_O}{-1.25} - 1 \right), \text{ where } V_O \text{ is the output in volts.}$$

C1 is a 1-μF solid tantalum capacitor required only if the regulator is more than 10 cm (4 in) from the power-supply filter capacitor. C2 is a 1-μF solid tantalum or 10-μF aluminum electrolytic capacitor required for stability.

Figure 1. Adjustable Negative-Voltage Regulator

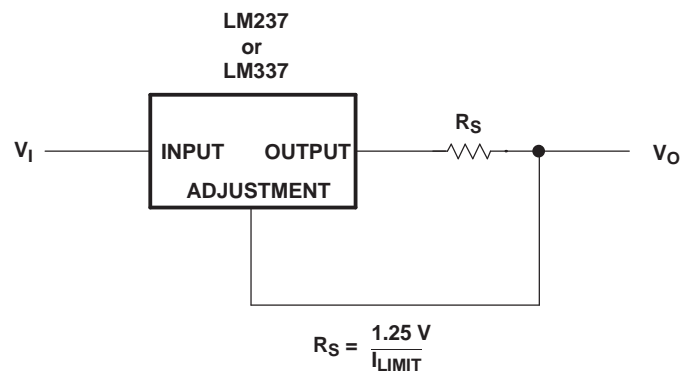

Figure 2. Current-Limiting Circuit

PACKAGING INFORMATION

Orderable Device	Status ⁽¹⁾	Package Type	Package Drawing	Pins	Package Qty	Eco Plan ⁽²⁾	Lead/Ball Finish	MSL Peak Temp ⁽³⁾
LM237KC	NRND	TO-220	KC	3	50	Pb-Free (RoHS)	CU SN	N / A for Pkg Type
LM237KCE3	NRND	TO-220	KC	3	50	Pb-Free (RoHS)	CU SN	N / A for Pkg Type
LM237KCSE3	ACTIVE	TO-220	KCS	3	50	Pb-Free (RoHS)	CU SN	N / A for Pkg Type
LM237KTER	OBSOLETE	PFM	KTE	3		TBD	Call TI	Call TI
LM337KC	NRND	TO-220	KC	3	50	Pb-Free (RoHS)	CU SN	N / A for Pkg Type
LM337KCE3	NRND	TO-220	KC	3	50	Pb-Free (RoHS)	CU SN	N / A for Pkg Type
LM337KCSE3	ACTIVE	TO-220	KCS	3	50	Pb-Free (RoHS)	CU SN	N / A for Pkg Type
LM337KTER	NRND	PFM	KTE	3	2000	TBD	CU SN	Level-3-240C-168 HR
LM337KTPR	NRND	PFM	KTP	2	3000	Green (RoHS & no Sb/Br)	CU SN	Level-1-260C-UNLIM
LM337KTPRG3	NRND	PFM	KTP	2	3000	Green (RoHS & no Sb/Br)	CU SN	Level-1-260C-UNLIM
LM337KTTR	ACTIVE	DDPAK/ TO-263	KTT	3	500	Green (RoHS & no Sb/Br)	CU SN	Level-3-245C-168 HR
LM337KTTRG3	ACTIVE	DDPAK/ TO-263	KTT	3	500	Green (RoHS & no Sb/Br)	CU SN	Level-3-245C-168 HR
LM337KVURG3	ACTIVE	PFM	KVU	3	2500	Green (RoHS & no Sb/Br)	CU SN	Level-3-260C-168 HR
LM337Y	OBSOLETE	DIESALE	Y	0		TBD	Call TI	Call TI

⁽¹⁾ The marketing status values are defined as follows:

ACTIVE: Product device recommended for new designs.

LIFEBUY: TI has announced that the device will be discontinued, and a lifetime-buy period is in effect.

NRND: Not recommended for new designs. Device is in production to support existing customers, but TI does not recommend using this part in a new design.

PREVIEW: Device has been announced but is not in production. Samples may or may not be available.

OBSOLETE: TI has discontinued the production of the device.

⁽²⁾ Eco Plan - The planned eco-friendly classification: Pb-Free (RoHS), Pb-Free (RoHS Exempt), or Green (RoHS & no Sb/Br) - please check <http://www.ti.com/productcontent> for the latest availability information and additional product content details.

TBD: The Pb-Free/Green conversion plan has not been defined.

Pb-Free (RoHS): TI's terms "Lead-Free" or "Pb-Free" mean semiconductor products that are compatible with the current RoHS requirements for all 6 substances, including the requirement that lead not exceed 0.1% by weight in homogeneous materials. Where designed to be soldered at high temperatures, TI Pb-Free products are suitable for use in specified lead-free processes.

Pb-Free (RoHS Exempt): This component has a RoHS exemption for either 1) lead-based flip-chip solder bumps used between the die and package, or 2) lead-based die adhesive used between the die and leadframe. The component is otherwise considered Pb-Free (RoHS compatible) as defined above.

Green (RoHS & no Sb/Br): TI defines "Green" to mean Pb-Free (RoHS compatible), and free of Bromine (Br) and Antimony (Sb) based flame retardants (Br or Sb do not exceed 0.1% by weight in homogeneous material)

⁽³⁾ MSL, Peak Temp. -- The Moisture Sensitivity Level rating according to the JEDEC industry standard classifications, and peak solder temperature.

Important Information and Disclaimer:The information provided on this page represents TI's knowledge and belief as of the date that it is provided. TI bases its knowledge and belief on information provided by third parties, and makes no representation or warranty as to the accuracy of such information. Efforts are underway to better integrate information from third parties. TI has taken and continues to take reasonable steps to provide representative and accurate information but may not have conducted destructive testing or chemical analysis on

incoming materials and chemicals. TI and TI suppliers consider certain information to be proprietary, and thus CAS numbers and other limited information may not be available for release.

In no event shall TI's liability arising out of such information exceed the total purchase price of the TI part(s) at issue in this document sold by TI to Customer on an annual basis.

TAPE AND REEL BOX INFORMATION

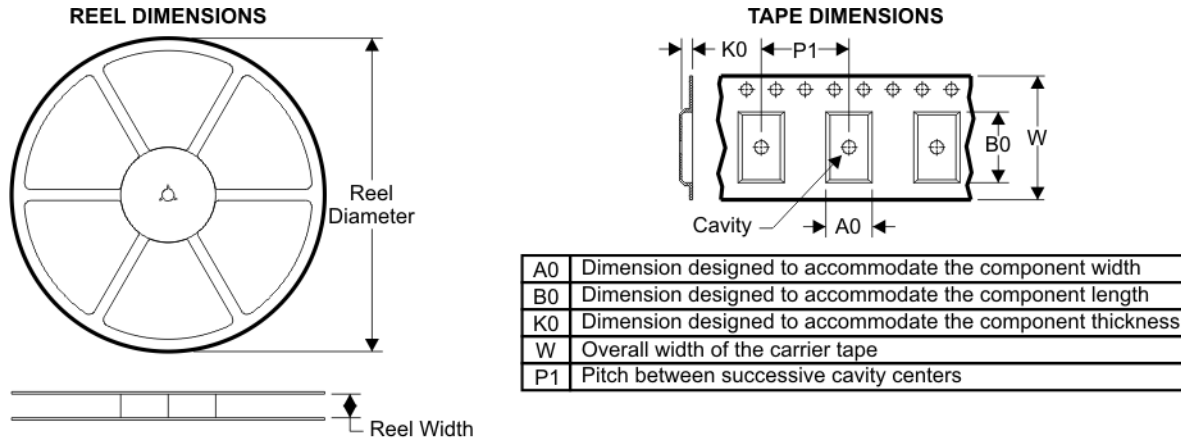

QUADRANT ASSIGNMENTS FOR PIN 1 ORIENTATION IN TAPE



Device	Package	Pins	Site	Reel Diameter (mm)	Reel Width (mm)	A0 (mm)	B0 (mm)	K0 (mm)	P1 (mm)	W (mm)	Pin1 Quadrant
LM337KTTR	KTT	3	SITE 45	330	24	10.6	15.8	4.9	16	24	Q2
LM337KVURG3	KVU	3	SITE 45	330	16	6.9	10.5	2.7	8	16	Q2

TAPE AND REEL BOX DIMENSIONS



Device	Package	Pins	Site	Length (mm)	Width (mm)	Height (mm)
LM337KTTR	KTT	3	SITE 45	340.0	340.0	38.0
LM337KVURG3	KVU	3	SITE 45	340.0	340.0	38.0

KTE (R-PSFM-G3)

PowerFLEX™ PLASTIC FLANGE-MOUNT

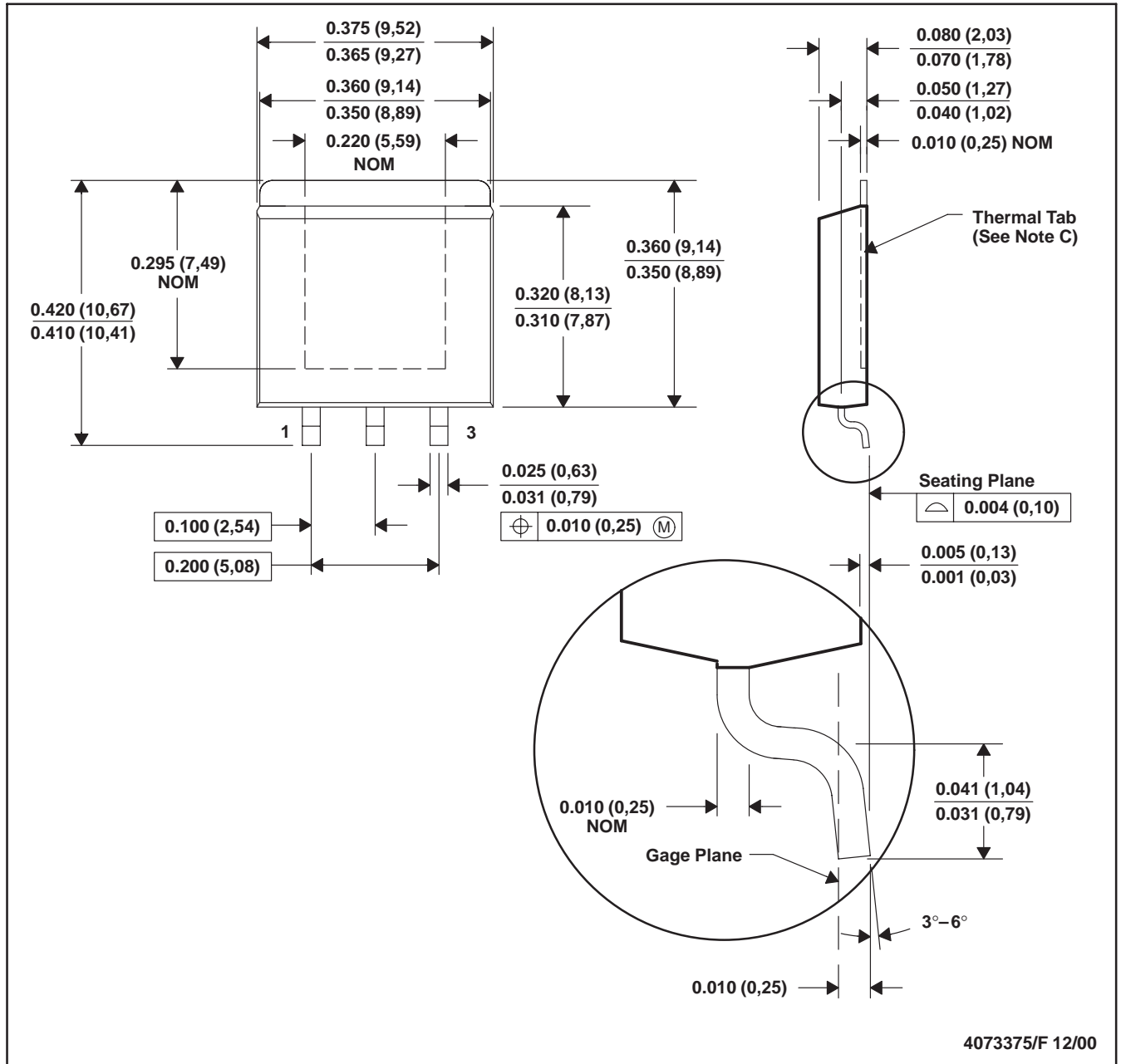

- NOTES: A. All linear dimensions are in inches (millimeters).
 B. This drawing is subject to change without notice.
 C. The center lead is in electrical contact with the thermal tab.
 D. Dimensions do not include mold protrusions, not to exceed 0.006 (0,15).
 E. Falls within JEDEC MO-169

PowerFLEX is a trademark of Texas Instruments.



KTP (R-PSFM-G2)

PowerFLEX™ PLASTIC FLANGE-MOUNT PACKAGE



- NOTES: A. All linear dimensions are in inches (millimeters).
 B. This drawing is subject to change without notice.
 C. The center lead is in electrical contact with the thermal tab.
 D. Dimensions do not include mold protrusions, not to exceed 0.006 (0,15).
 E. Falls within JEDEC TO-252 variation AC.

PowerFLEX is a trademark of Texas Instruments.



KTT (R-PSFM-G3)

PLASTIC FLANGE-MOUNT PACKAGE

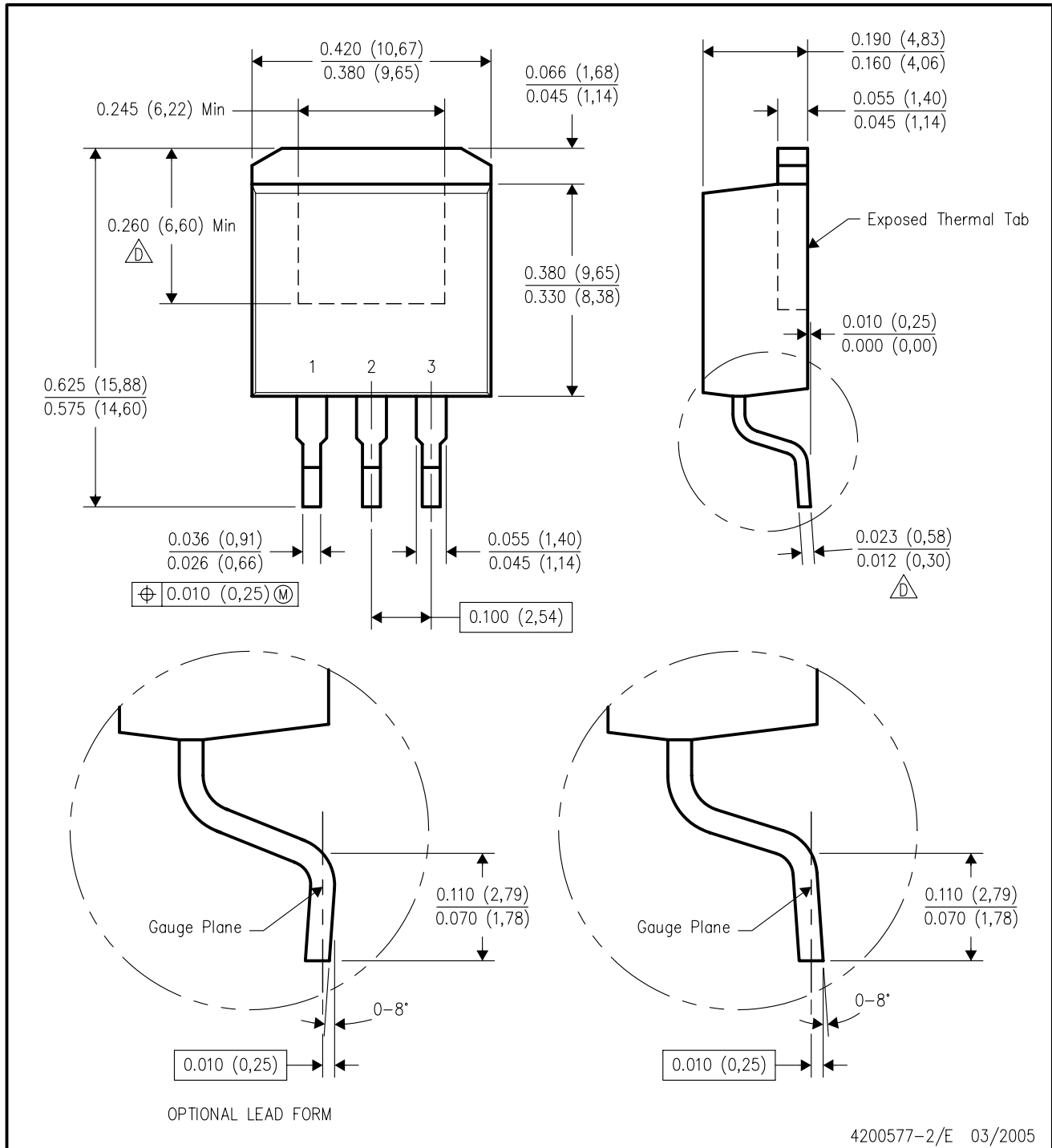

- NOTES:
- A. All linear dimensions are in inches (millimeters).
 - B. This drawing is subject to change without notice.
 - C. Body dimensions do not include mold flash or protrusion. Mold flash or protrusion not to exceed 0.005 (0,13) per side.
- △ Falls within JEDEC TO-263 variation AA, except minimum lead thickness and minimum exposed pad length.

KTT (R-PSFM-G3)

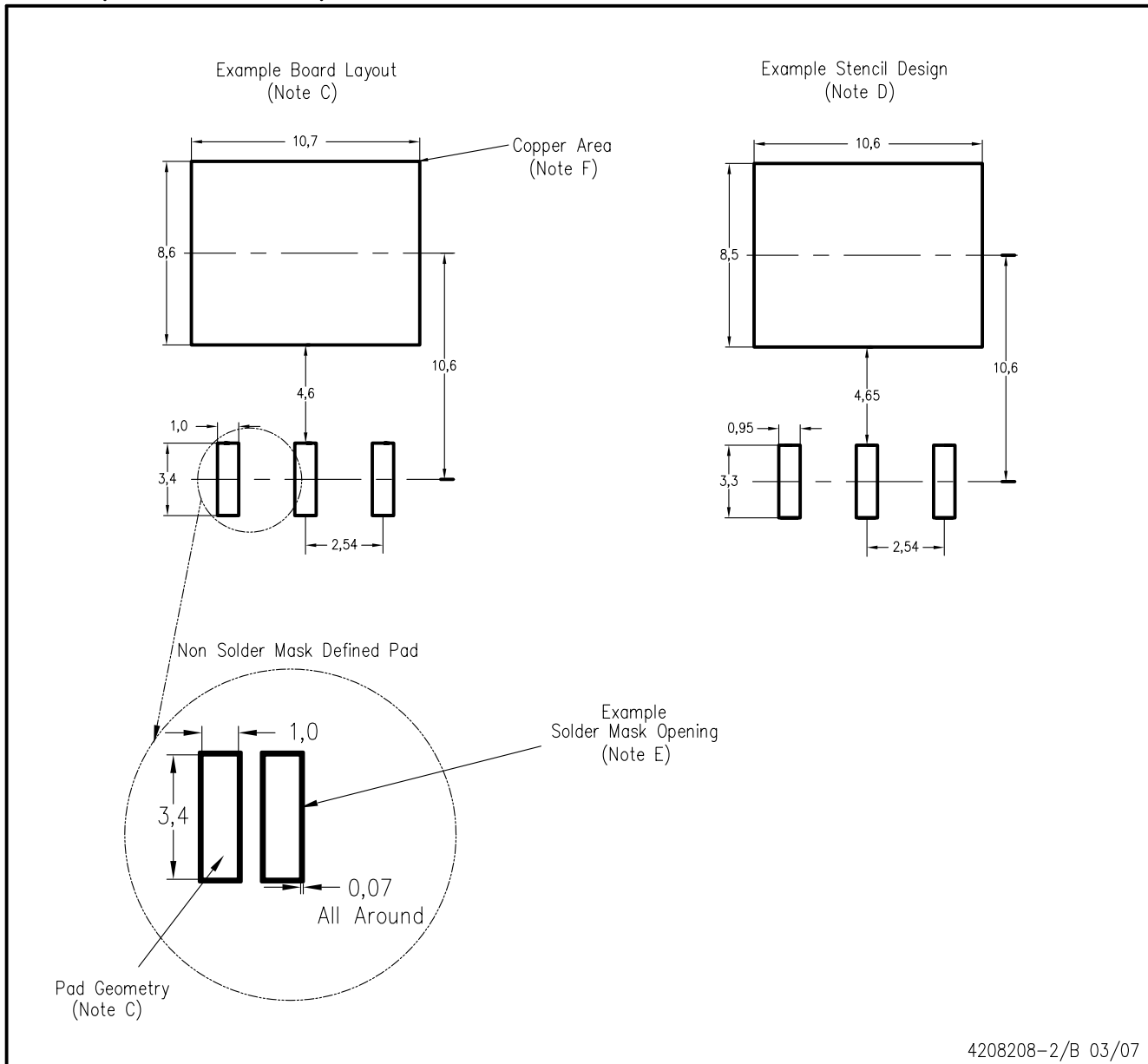

- NOTES:
- A. All linear dimensions are in millimeters.
 - B. This drawing is subject to change without notice.
 - C. Publication IPC-SM-782 is recommended for alternate designs.
 - D. Laser cutting apertures with trapezoidal walls and also rounding corners will offer better paste release. Customers should contact their board assembly site for stencil design recommendations. Refer to IPC-7525.
 - E. Customers should contact their board fabrication site for solder mask tolerances between and around signal pads.
 - F. This package is designed to be soldered to a thermal pad on the board. Refer to the Product Datasheet for specific thermal information, via requirements, and recommended thermal pad size. For thermal pad sizes larger than shown a solder mask defined pad is recommended in order to maintain the solderable pad geometry while increasing copper area.

KCS (R-PSFM-T3)

PLASTIC FLANGE-MOUNT PACKAGE

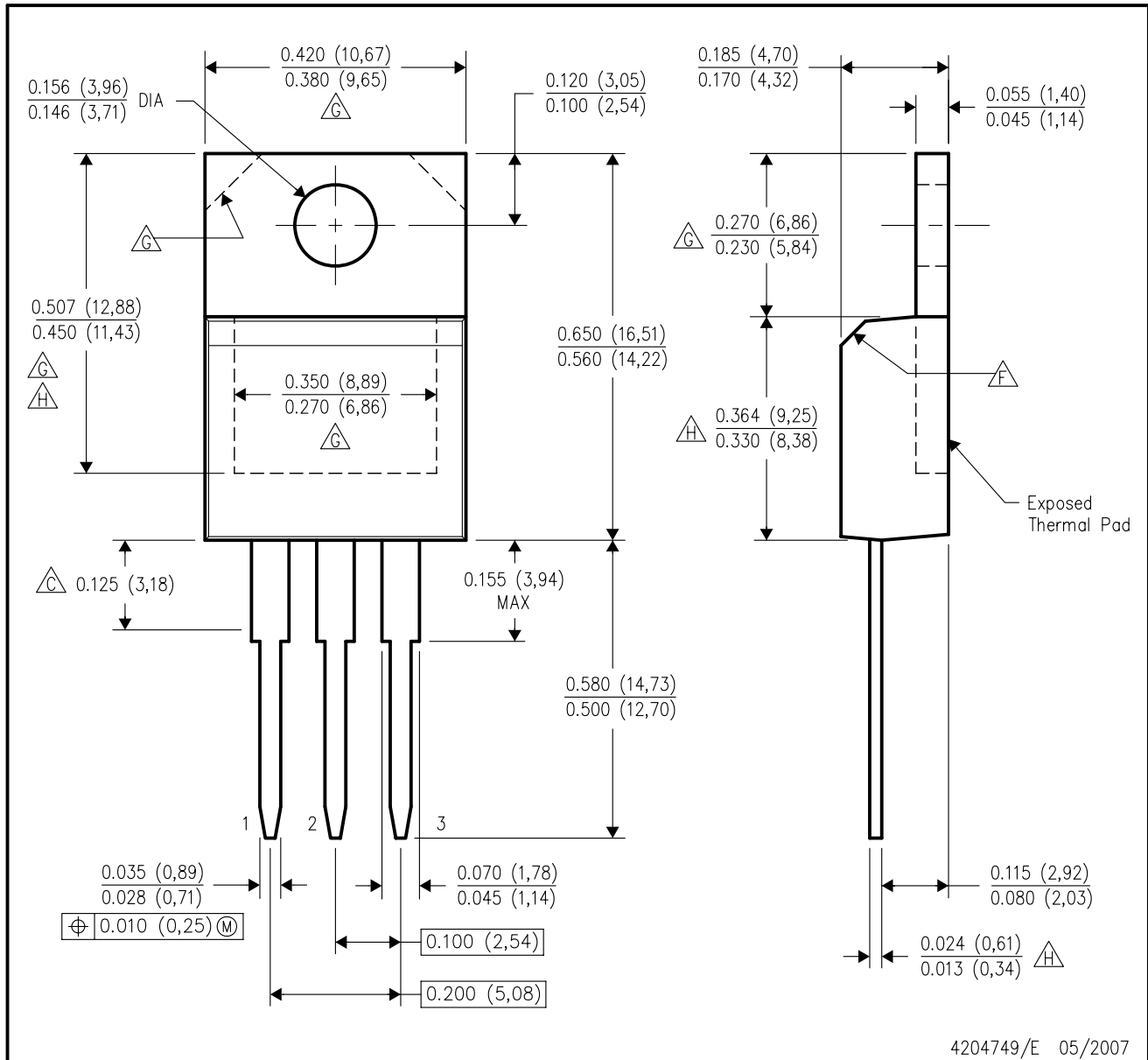

- NOTES:
- A. All linear dimensions are in inches (millimeters).
 - B. This drawing is subject to change without notice.
 - ΔC Lead dimensions are not controlled within this area.
 - D. All lead dimensions apply before solder dip.
 - E. The center lead is in electrical contact with the mounting tab.
 - ΔF The chamfer is optional.
 - ΔG Thermal pad contour optional within these dimensions.
 - ΔH Falls within JEDEC TO-220 variation AB, except minimum lead thickness, minimum exposed pad length, and maximum body length.

KVU (R-PSFM-G3)

PLASTIC FLANGE-MOUNT PACKAGE

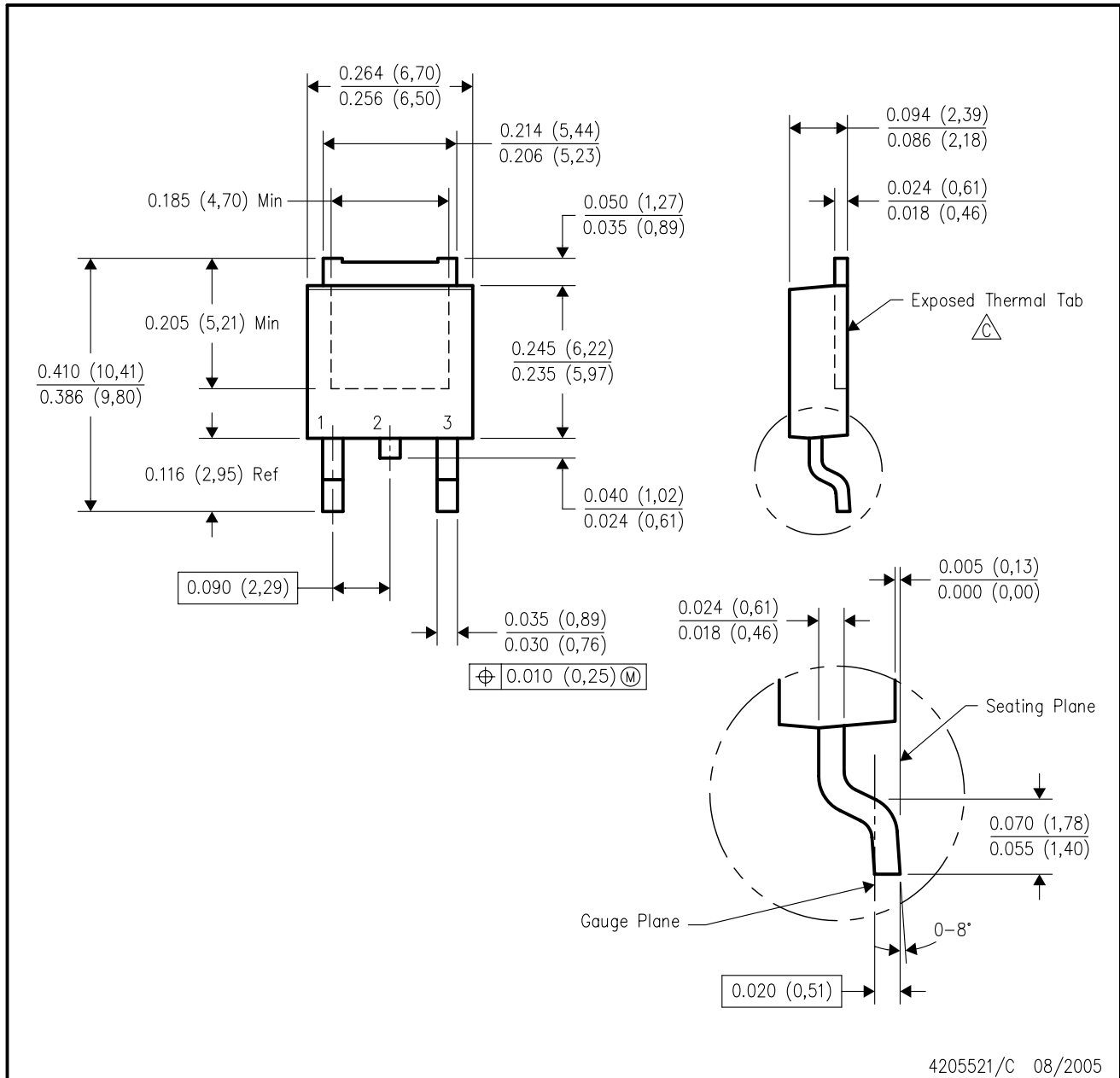

- NOTES:
- A. All linear dimensions are in inches (millimeters).
 - B. This drawing is subject to change without notice.
 - △ The center lead is in electrical contact with the exposed thermal tab.
 - D. Body Dimensions do not include mold flash or protrusions. Mold flash and protrusion shall not exceed 0.006 (0,15) per side.
 - E. Falls within JEDEC TO-252 variation AA.

KC (R-PSFM-T3)

PLASTIC FLANGE-MOUNT PACKAGE

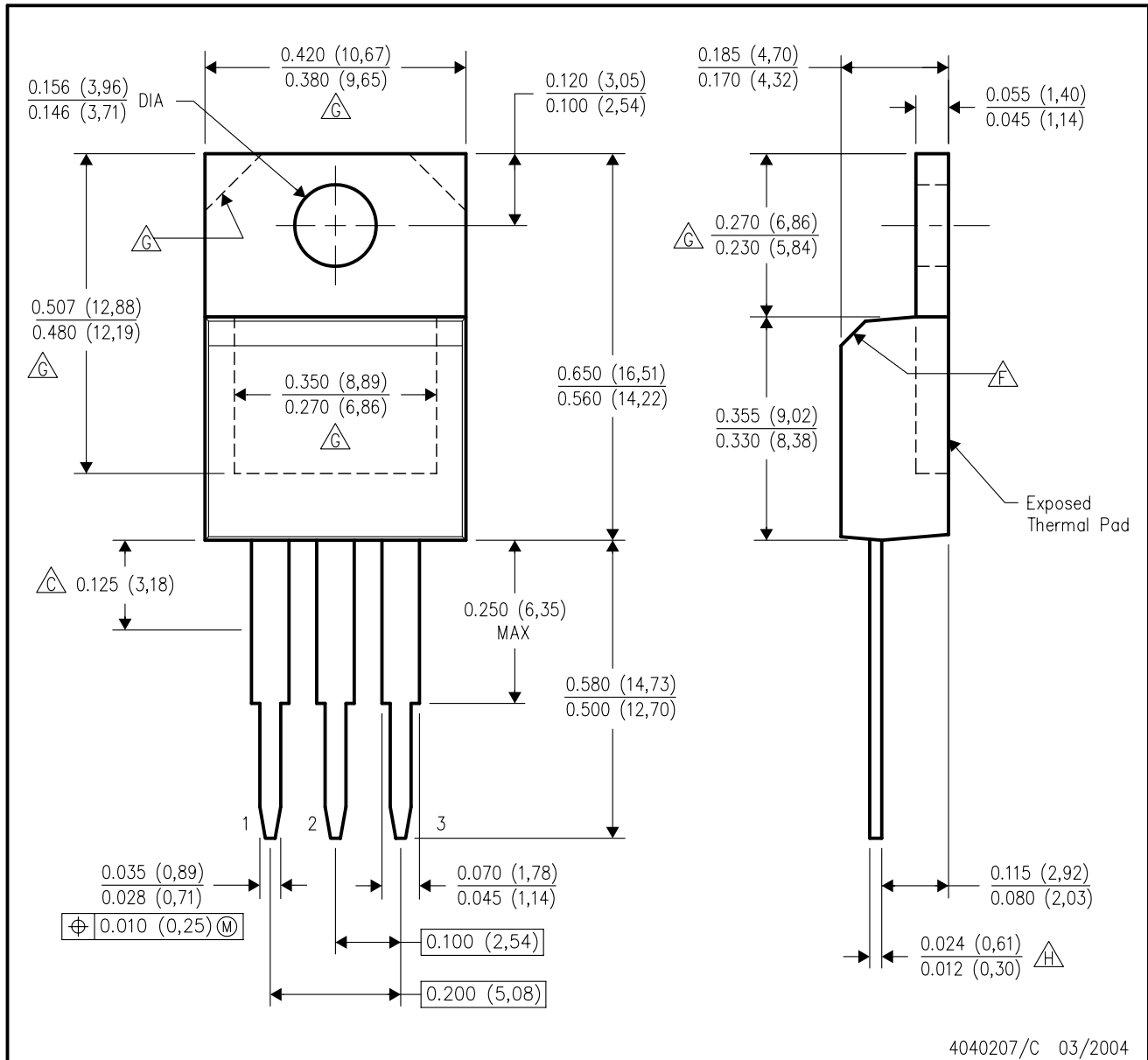

- NOTES:
- A. All linear dimensions are in inches (millimeters).
 - B. This drawing is subject to change without notice.
 - $\triangle C$ Lead dimensions are not controlled within this area.
 - D. All lead dimensions apply before solder dip.
 - E. The center lead is in electrical contact with the mounting tab.
 - $\triangle F$ The chamfer is optional.
 - $\triangle G$ Thermal pad contour optional within these dimensions.
 - $\triangle H$ Falls within JEDEC TO-220 variation AB, except minimum lead thickness.

IMPORTANT NOTICE

Texas Instruments Incorporated and its subsidiaries (TI) reserve the right to make corrections, modifications, enhancements, improvements, and other changes to its products and services at any time and to discontinue any product or service without notice. Customers should obtain the latest relevant information before placing orders and should verify that such information is current and complete. All products are sold subject to TI's terms and conditions of sale supplied at the time of order acknowledgment.

TI warrants performance of its hardware products to the specifications applicable at the time of sale in accordance with TI's standard warranty. Testing and other quality control techniques are used to the extent TI deems necessary to support this warranty. Except where mandated by government requirements, testing of all parameters of each product is not necessarily performed.

TI assumes no liability for applications assistance or customer product design. Customers are responsible for their products and applications using TI components. To minimize the risks associated with customer products and applications, customers should provide adequate design and operating safeguards.

TI does not warrant or represent that any license, either express or implied, is granted under any TI patent right, copyright, mask work right, or other TI intellectual property right relating to any combination, machine, or process in which TI products or services are used. Information published by TI regarding third-party products or services does not constitute a license from TI to use such products or services or a warranty or endorsement thereof. Use of such information may require a license from a third party under the patents or other intellectual property of the third party, or a license from TI under the patents or other intellectual property of TI.

Reproduction of TI information in TI data books or data sheets is permissible only if reproduction is without alteration and is accompanied by all associated warranties, conditions, limitations, and notices. Reproduction of this information with alteration is an unfair and deceptive business practice. TI is not responsible or liable for such altered documentation. Information of third parties may be subject to additional restrictions.

Resale of TI products or services with statements different from or beyond the parameters stated by TI for that product or service voids all express and any implied warranties for the associated TI product or service and is an unfair and deceptive business practice. TI is not responsible or liable for any such statements.

TI products are not authorized for use in safety-critical applications (such as life support) where a failure of the TI product would reasonably be expected to cause severe personal injury or death, unless officers of the parties have executed an agreement specifically governing such use. Buyers represent that they have all necessary expertise in the safety and regulatory ramifications of their applications, and acknowledge and agree that they are solely responsible for all legal, regulatory and safety-related requirements concerning their products and any use of TI products in such safety-critical applications, notwithstanding any applications-related information or support that may be provided by TI. Further, Buyers must fully indemnify TI and its representatives against any damages arising out of the use of TI products in such safety-critical applications.

TI products are neither designed nor intended for use in military/aerospace applications or environments unless the TI products are specifically designated by TI as military-grade or "enhanced plastic." Only products designated by TI as military-grade meet military specifications. Buyers acknowledge and agree that any such use of TI products which TI has not designated as military-grade is solely at the Buyer's risk, and that they are solely responsible for compliance with all legal and regulatory requirements in connection with such use.

TI products are neither designed nor intended for use in automotive applications or environments unless the specific TI products are designated by TI as compliant with ISO/TS 16949 requirements. Buyers acknowledge and agree that, if they use any non-designated products in automotive applications, TI will not be responsible for any failure to meet such requirements.

Following are URLs where you can obtain information on other Texas Instruments products and application solutions:

Products		Applications	
Amplifiers	amplifier.ti.com	Audio	www.ti.com/audio
Data Converters	dataconverter.ti.com	Automotive	www.ti.com/automotive
DSP	dsp.ti.com	Broadband	www.ti.com/broadband
Interface	interface.ti.com	Digital Control	www.ti.com/digitalcontrol
Logic	logic.ti.com	Military	www.ti.com/military
Power Mgmt	power.ti.com	Optical Networking	www.ti.com/opticalnetwork
Microcontrollers	microcontroller.ti.com	Security	www.ti.com/security
RFID	www.ti-rfid.com	Telephony	www.ti.com/telephony
Low Power Wireless	www.ti.com/lpw	Video & Imaging	www.ti.com/video
		Wireless	www.ti.com/wireless

Mailing Address: Texas Instruments, Post Office Box 655303, Dallas, Texas 75265
Copyright © 2007, Texas Instruments Incorporated