

# LM136-2.5

*LM136-2.5 LM236-2.5 LM336-2.5V Reference Diode*



Literature Number: SNVS749E

## Reference Diode

### General Description

The LM136-2.5/LM236-2.5 and LM336-2.5 integrated circuits are precision 2.5V shunt regulator diodes. These monolithic IC voltage references operate as a low-temperature-coefficient 2.5V zener with 0.2Ω dynamic impedance. A third terminal on the LM136-2.5 allows the reference voltage and temperature coefficient to be trimmed easily.

The LM136-2.5 series is useful as a precision 2.5V low voltage reference for digital voltmeters, power supplies or op amp circuitry. The 2.5V make it convenient to obtain a stable reference from 5V logic supplies. Further, since the LM136-2.5 operates as a shunt regulator, it can be used as either a positive or negative voltage reference.

The LM136-2.5 is rated for operation over -55°C to +125°C while the LM236-2.5 is rated over a -25°C to +85°C temperature range.

The LM336-2.5 is rated for operation over a 0°C to +70°C temperature range. See the connection diagrams for available packages.

### Features

- Low temperature coefficient
- Wide operating current of 400 μA to 10 mA
- 0.2Ω dynamic impedance
- ±1% initial tolerance available
- Guaranteed temperature stability
- Easily trimmed for minimum temperature drift
- Fast turn-on

### Connection Diagrams

**TO-92**  
Plastic Package

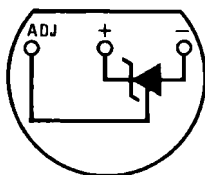

571508

**Bottom View**

Order Number LM336Z-2.5 or LM336BZ-2.5  
See NS Package Number Z03A

**TO-46**  
Metal Can Package

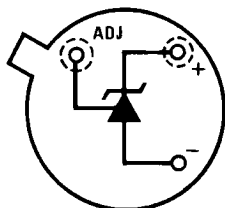

571520

**Bottom View**

Order Number LM136H-2.5,  
LM136H-2.5/883, LM236H-2.5,  
or LM236AH-2.5  
See NS Package Number H03H

**SO Package**

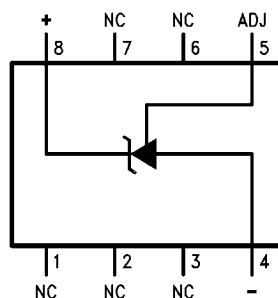

571512

**Top View**

Order Number LM236M-2.5,  
LM236AM-2.5, LM336M-2.5  
or LM336BM-2.5  
See NS Package Number M08A

# Typical Applications

## 2.5V Reference

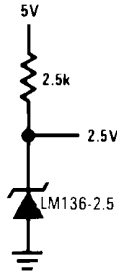

571509

## 2.5V Reference with Minimum Temperature Coefficient

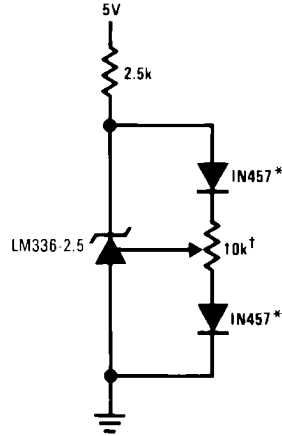

571510

†Adjust to 2.490V

\*Any silicon signal diode

## Wide Input Range Reference

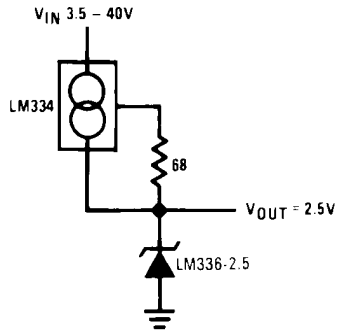

571511

**Absolute Maximum Ratings** (Note 1)

If Military/Aerospace specified devices are required, please contact the National Semiconductor Sales Office/Distributors for availability and specifications.

Reverse Current	15 mA
Forward Current	10 mA
Storage Temperature	-60°C to +150°C
Operating Temperature Range (Note 2)	
LM136	-55°C to +150°C
LM236	-25°C to +85°C

LM336 0°C to +70°C

## Soldering Information

TO-92 Package (10 sec.)	260°C
TO-46 Package (10 sec.)	300°C
SO Package	
Vapor Phase (60 sec.)	215°C
Infrared (15 sec.)	220°C

See AN-450 "Surface Mounting Methods and Their Effect on Product Reliability" (Appendix D) for other methods of soldering surface mount devices.

**Electrical Characteristics** (Note 3)

Parameter	Conditions	LM136A-2.5/LM236A-2.5			LM336B-2.5			Units
		LM136-2.5/LM236-2.5			LM336-2.5			
		Min	Typ	Max	Min	Typ	Max	
Reverse Breakdown Voltage	$T_A=25^\circ\text{C}$ , $I_R=1\text{ mA}$							
	LM136, LM236, LM336	2.440	2.490	2.540	2.390	2.490	2.590	V
	LM136A, LM236A, LM336B	2.465	2.490	2.515	2.440	2.490	2.540	V
Reverse Breakdown Change With Current	$T_A=25^\circ\text{C}$ , $400\ \mu\text{A} \leq I_R \leq 10\text{ mA}$		2.6	6		2.6	10	mV
Reverse Dynamic Impedance	$T_A=25^\circ\text{C}$ , $I_R=1\text{ mA}$ , $f = 100\text{ Hz}$		0.2	0.6		0.2	1	$\Omega$
Temperature Stability (Note 4)	$V_R$ Adjusted to 2.490V $I_R=1\text{ mA}$ , <i>Figure 2</i> $0^\circ\text{C} \leq T_A \leq 70^\circ\text{C}$ (LM336)					1.8	6	mV
	$-25^\circ\text{C} \leq T_A \leq +85^\circ\text{C}$ (LM236H, LM236Z)		3.5	9				mV
	$-25^\circ\text{C} \leq T_A \leq +85^\circ\text{C}$ (LM236M)		7.5	18				mV
	$-55^\circ\text{C} \leq T_A \leq +125^\circ\text{C}$ (LM136)		12	18				mV
Reverse Breakdown Change With Current	$400\ \mu\text{A} \leq I_R \leq 10\text{ mA}$		3	10		3	12	mV
Reverse Dynamic Impedance	$I_R=1\text{ mA}$		0.4	1		0.4	1.4	$\Omega$
Long Term Stability	$T_A=25^\circ\text{C} \pm 0.1^\circ\text{C}$ , $I_R=1\text{ mA}$ , $t = 1000\text{ hrs}$		20			20		ppm

**Note 1:** Absolute Maximum Ratings indicate limits beyond which damage to the device may occur. Electrical specifications do not apply when operating the device beyond its specified operating conditions.

**Note 2:** For elevated temperature operation,  $T_j$  max is:

LM136	150°C
LM236	125°C
LM336	100°C

Thermal Resistance	TO-92	TO-46	SO-8
$\theta_{ja}$ (Junction to Ambient)	180°C/W (0.4 leads) 170°C/W (0.125 lead)	440°C/W	165°C/W
$\theta_{jc}$ (Junction to Case)	n/a	80°C/W	n/a

**Note 3:** Unless otherwise specified, the LM136-2.5 is specified from  $-55^{\circ}\text{C} \leq T_A \leq +125^{\circ}\text{C}$ , the LM236-2.5 from  $-25^{\circ}\text{C} \leq T_A \leq +85^{\circ}\text{C}$  and the LM336-2.5 from  $0^{\circ}\text{C} \leq T_A \leq +70^{\circ}\text{C}$ .

**Note 4:** Temperature stability for the LM336 and LM236 family is guaranteed by design. Design limits are guaranteed (but not 100% production tested) over the indicated temperature and supply voltage ranges. These limits are not used to calculate outgoing quality levels. Stability is defined as the maximum change in  $V_{\text{ref}}$  from  $25^{\circ}\text{C}$  to  $T_A$  (min) or  $T_A$  (max).

# Typical Performance Characteristics

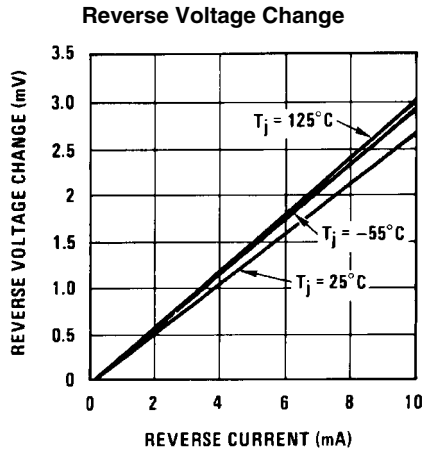

571521

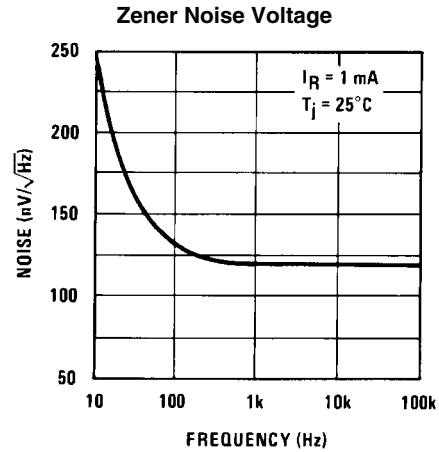

571522

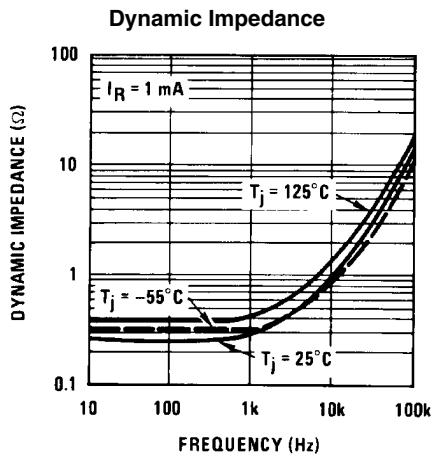

571523

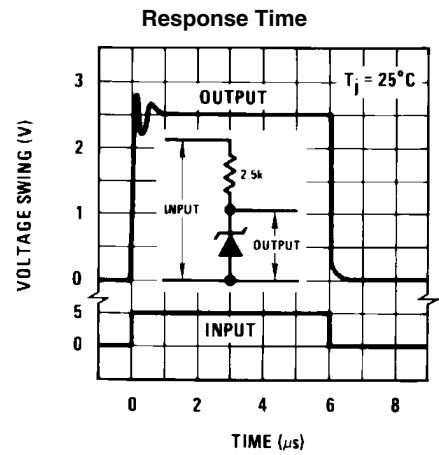

571524

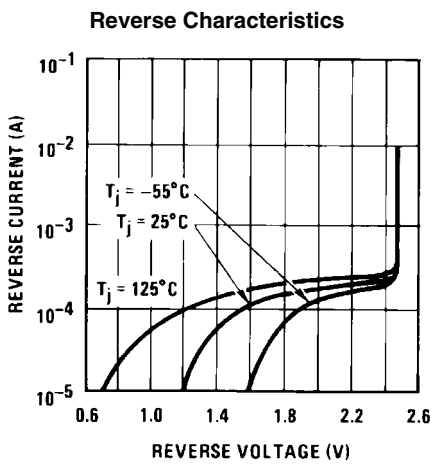

571525

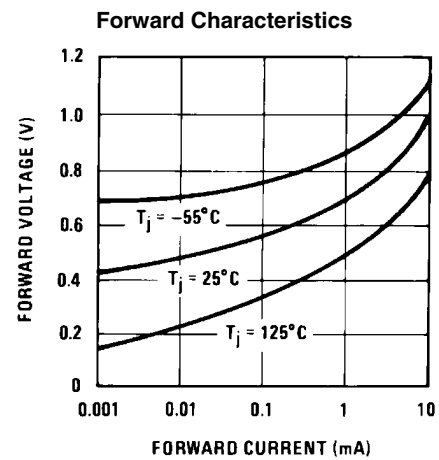

571526

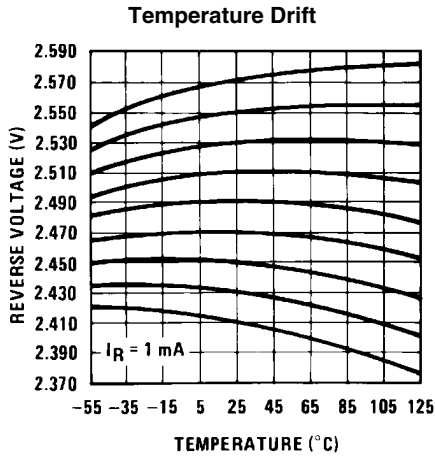

571527

### Application Hints

The LM136 series voltage references are much easier to use than ordinary zener diodes. Their low impedance and wide operating current range simplify biasing in almost any circuit. Further, either the breakdown voltage or the temperature coefficient can be adjusted to optimize circuit performance.

Figure 1 shows an LM136 with a 10k potentiometer for adjusting the reverse breakdown voltage. With the addition of R1 the breakdown voltage can be adjusted without affecting the temperature coefficient of the device. The adjustment range is usually sufficient to adjust for both the initial device tolerance and inaccuracies in buffer circuitry.

If minimum temperature coefficient is desired, two diodes can be added in series with the adjustment potentiometer as shown in Figure 2. When the device is adjusted to 2.490V the temperature coefficient is minimized. Almost any silicon signal diode can be used for this purpose such as a 1N914, 1N4148 or a 1N457. For proper temperature compensation the diodes should be in the same thermal environment as the LM136. It is usually sufficient to mount the diodes near the LM136 on the printed circuit board. The absolute resistance of R1 is not critical and any value from 2k to 20k will work.

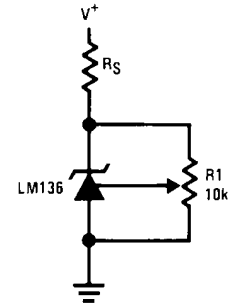

571528

FIGURE 1. LM136 With Pot for Adjustment of Breakdown Voltage (Trim Range = ±120 mV typical)

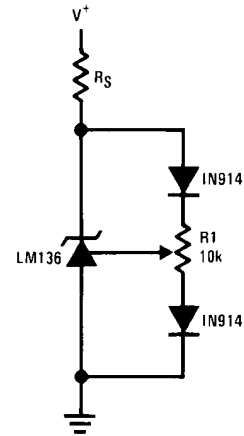

571529

FIGURE 2. Temperature Coefficient Adjustment (Trim Range = ±70 mV typical)

### Low Cost 2 Amp Switching Regulator†

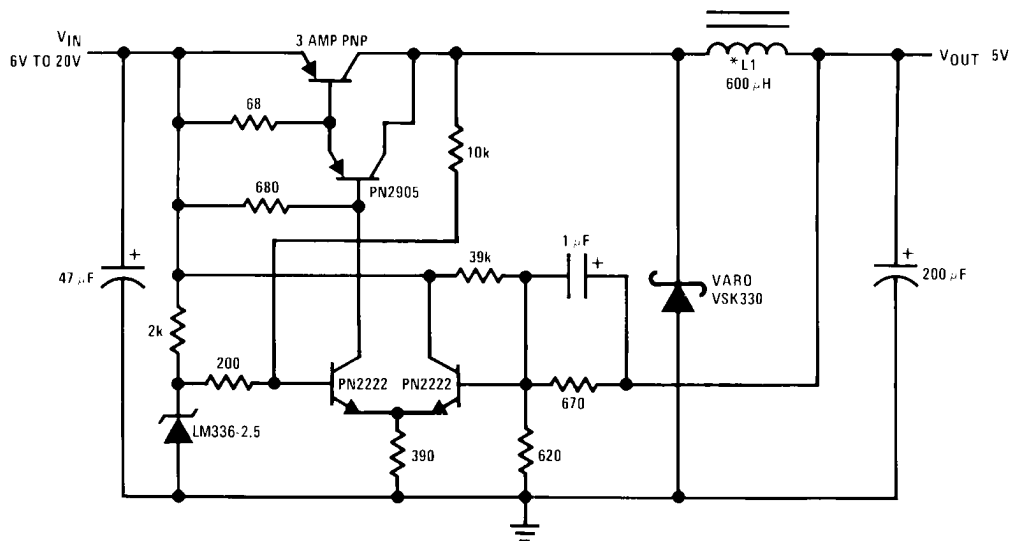

571505

\*L1 60 turns #16 wire on Arnold Core A-254168-2

†Efficiency ≈ 80%

**Precision Power Regulator with Low Temperature Coefficient**

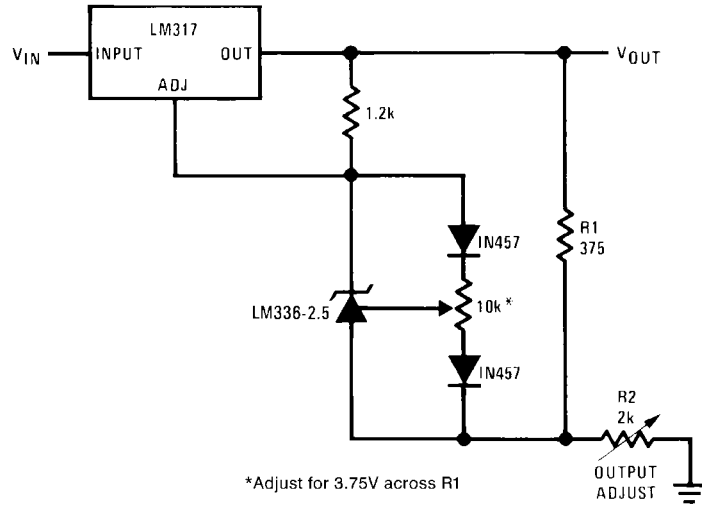

**5V Crowbar**

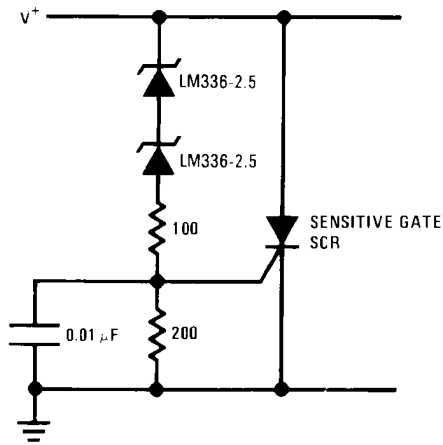

571514

**Trimmed 2.5V Reference with Temperature Coefficient Independent of Breakdown Voltage**

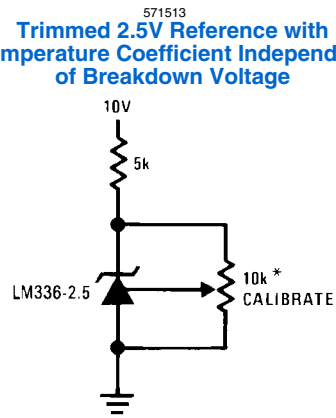

\*Does not affect temperature coefficient

571515

**Adjustable Shunt Regulator**

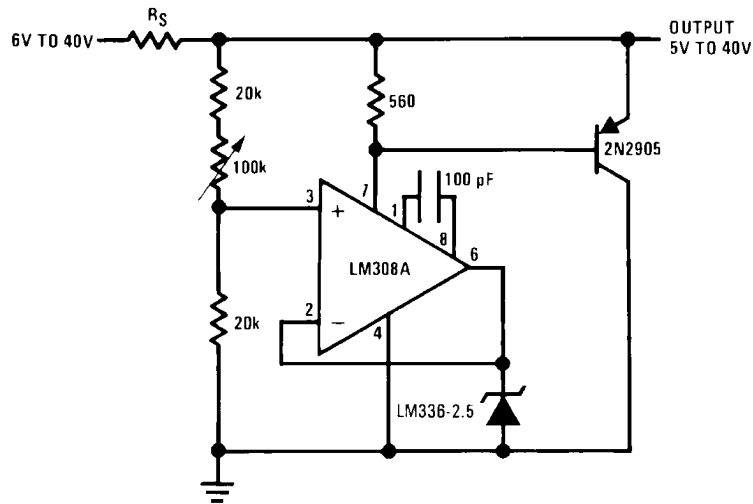

571506



Linear Ohmmeter

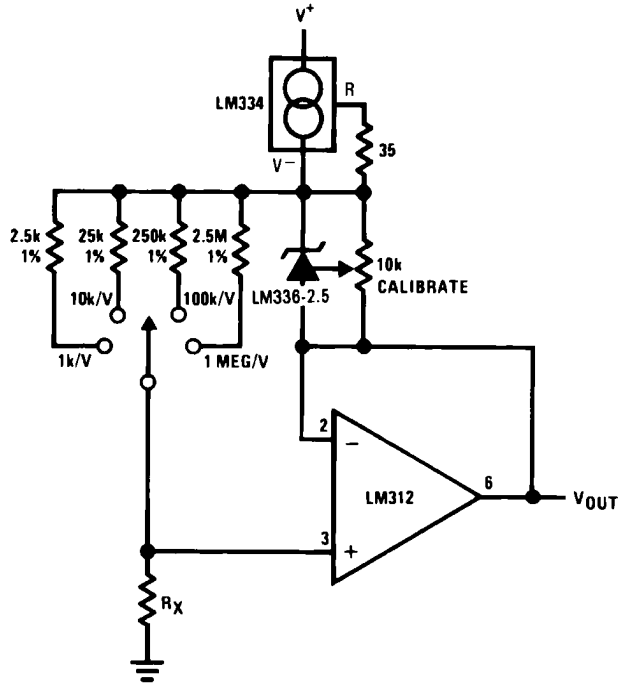

571516

Op Amp with Output Clamped

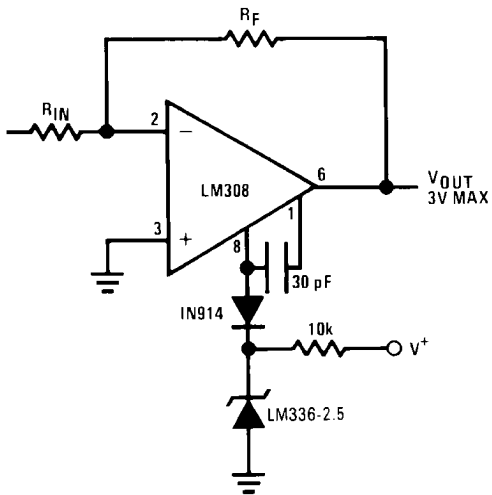

571517

Bipolar Output Reference

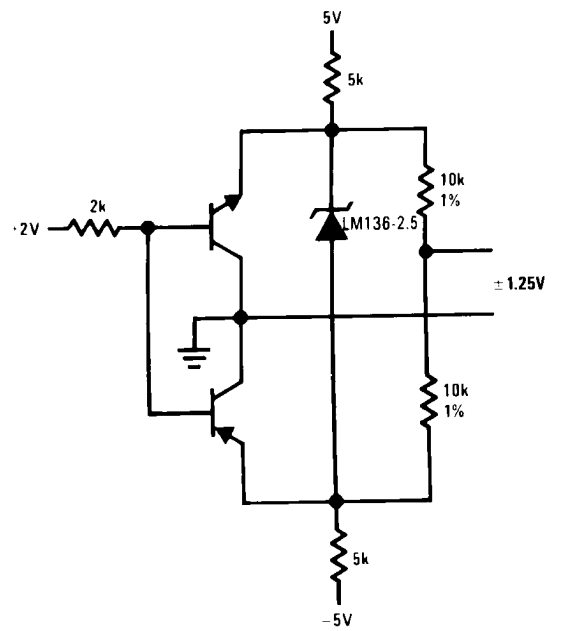

571518

### 2.5V Square Wave Calibrator

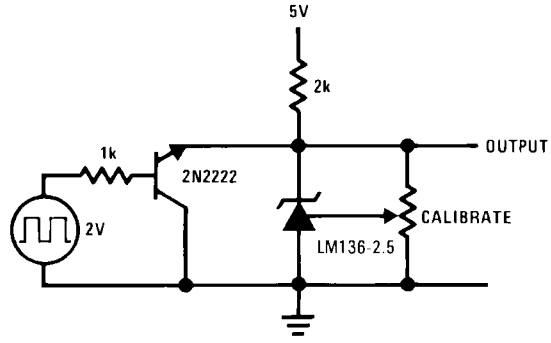

571519

### 5V Buffered Reference

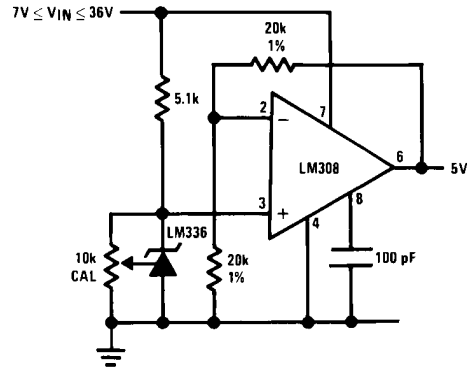

571530

### Low Noise Buffered Reference

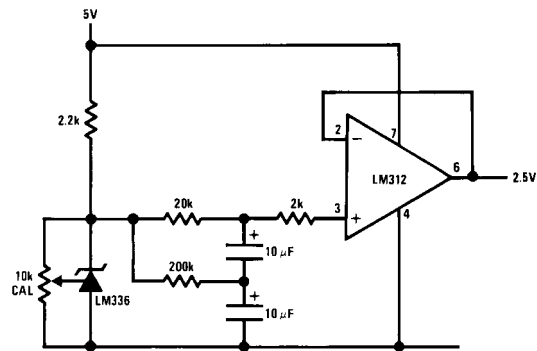

571531

# Schematic Diagram

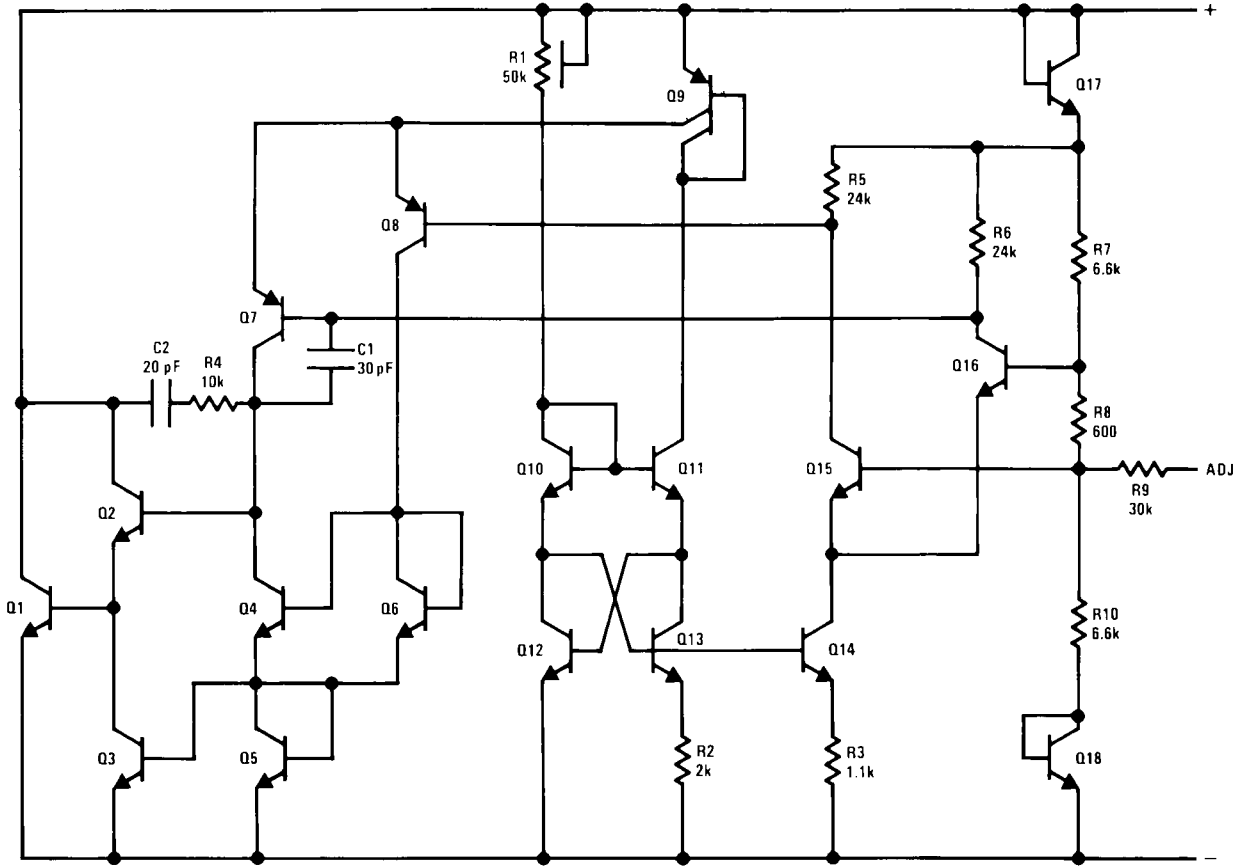

571501

**Physical Dimensions** inches (millimeters) unless otherwise noted

LM136-2.5/LM236-2.5/LM336-2.5V

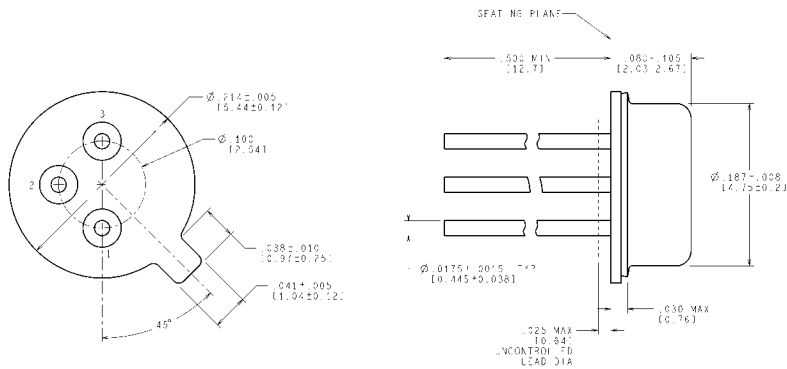

CONTROLLING DIMENSION IS INCH  
VALUES IN [ ] ARE IN MILLIMETERS

H03H (Rev F)

**Order Number LM136H-2.5, LM136H-2.5/883, LM236H-2.5, LM136AH-2.5, LM136AH-2.5/883 or LM236AH-2.5**  
**NS Package Number H03H**

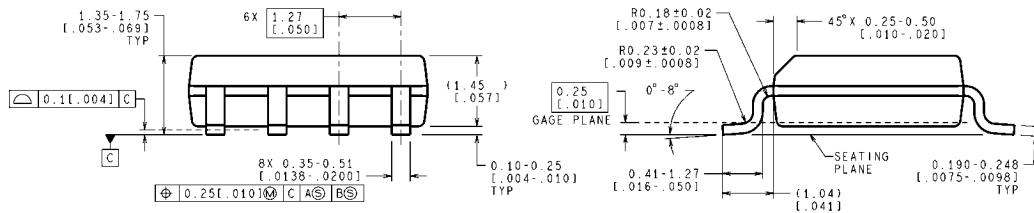
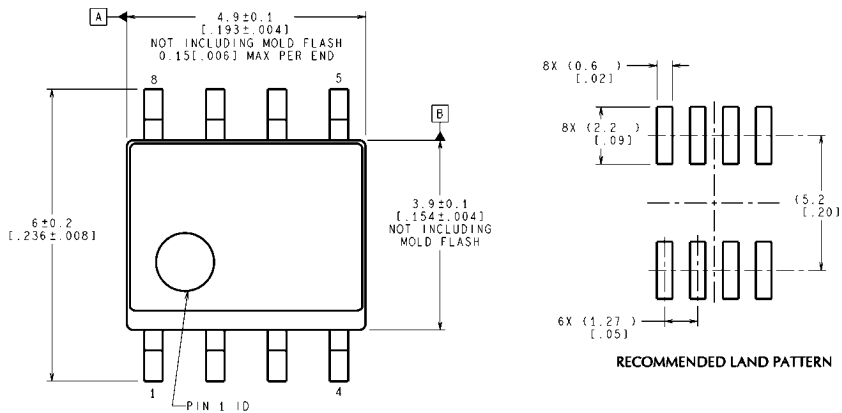

CONTROLLING DIMENSION IS MILLIMETER  
VALUES IN [ ] ARE INCHES  
DIMENSIONS IN ( ) FOR REFERENCE ONLY

M08A (Rev L)

**Small Outline (SO) Package (M)**  
**Order Number LM236M-2.5, LM236AM-2.5, LM336M-2.5 or LM336BM-2.5**  
**NS Package Number M08A**

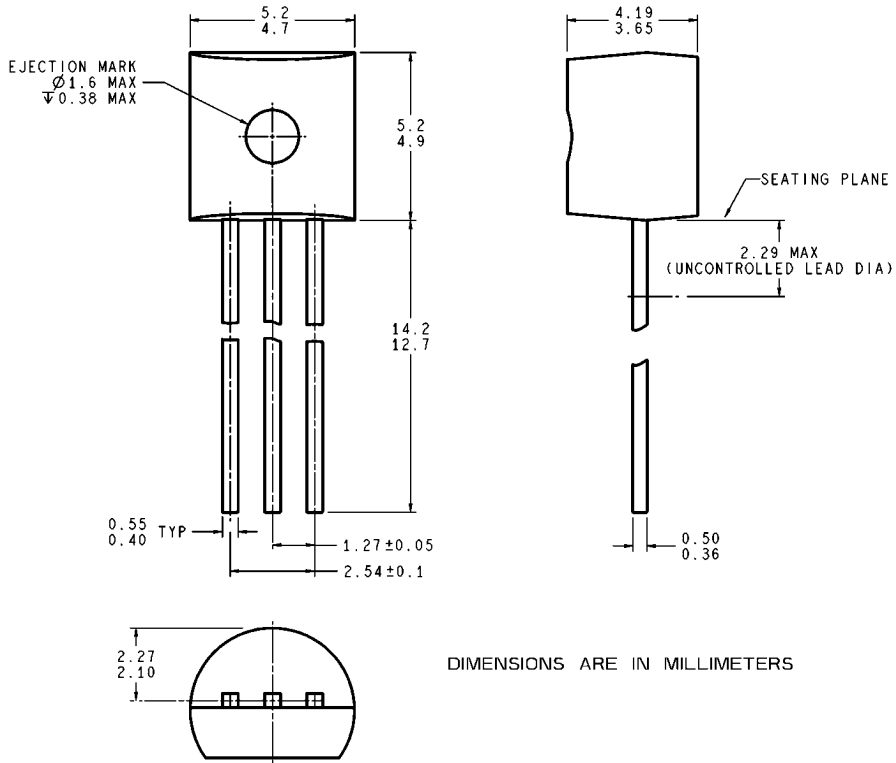

DIMENSIONS ARE IN MILLIMETERS

Z03A (Rev G)

**TO-92 Plastic Package (Z)**  
**Order Number LM336Z-2.5 or LM336BZ-2.5**  
**NS Package Number Z03A**

# Notes

LM136-2.5/LM236-2.5/LM336-2.5V

## Notes

For more National Semiconductor product information and proven design tools, visit the following Web sites at:

Products		Design Support	
Amplifiers	<a href="http://www.national.com/amplifiers">www.national.com/amplifiers</a>	WEBENCH® Tools	<a href="http://www.national.com/webench">www.national.com/webench</a>
Audio	<a href="http://www.national.com/audio">www.national.com/audio</a>	App Notes	<a href="http://www.national.com/appnotes">www.national.com/appnotes</a>
Clock and Timing	<a href="http://www.national.com/timing">www.national.com/timing</a>	Reference Designs	<a href="http://www.national.com/refdesigns">www.national.com/refdesigns</a>
Data Converters	<a href="http://www.national.com/adc">www.national.com/adc</a>	Samples	<a href="http://www.national.com/samples">www.national.com/samples</a>
Interface	<a href="http://www.national.com/interface">www.national.com/interface</a>	Eval Boards	<a href="http://www.national.com/evalboards">www.national.com/evalboards</a>
LVDS	<a href="http://www.national.com/lvds">www.national.com/lvds</a>	Packaging	<a href="http://www.national.com/packaging">www.national.com/packaging</a>
Power Management	<a href="http://www.national.com/power">www.national.com/power</a>	Green Compliance	<a href="http://www.national.com/quality/green">www.national.com/quality/green</a>
Switching Regulators	<a href="http://www.national.com/switchers">www.national.com/switchers</a>	Distributors	<a href="http://www.national.com/contacts">www.national.com/contacts</a>
LDOs	<a href="http://www.national.com/ldo">www.national.com/ldo</a>	Quality and Reliability	<a href="http://www.national.com/quality">www.national.com/quality</a>
LED Lighting	<a href="http://www.national.com/led">www.national.com/led</a>	Feedback/Support	<a href="http://www.national.com/feedback">www.national.com/feedback</a>
Voltage Reference	<a href="http://www.national.com/vref">www.national.com/vref</a>	Design Made Easy	<a href="http://www.national.com/easy">www.national.com/easy</a>
PowerWise® Solutions	<a href="http://www.national.com/powerwise">www.national.com/powerwise</a>	Solutions	<a href="http://www.national.com/solutions">www.national.com/solutions</a>
Serial Digital Interface (SDI)	<a href="http://www.national.com/sdi">www.national.com/sdi</a>	Mil/Aero	<a href="http://www.national.com/milaero">www.national.com/milaero</a>
Temperature Sensors	<a href="http://www.national.com/tempsensors">www.national.com/tempsensors</a>	SolarMagic™	<a href="http://www.national.com/solarmagic">www.national.com/solarmagic</a>
Wireless (PLL/VCO)	<a href="http://www.national.com/wireless">www.national.com/wireless</a>	Analog University®	<a href="http://www.national.com/AU">www.national.com/AU</a>

THE CONTENTS OF THIS DOCUMENT ARE PROVIDED IN CONNECTION WITH NATIONAL SEMICONDUCTOR CORPORATION ("NATIONAL") PRODUCTS. NATIONAL MAKES NO REPRESENTATIONS OR WARRANTIES WITH RESPECT TO THE ACCURACY OR COMPLETENESS OF THE CONTENTS OF THIS PUBLICATION AND RESERVES THE RIGHT TO MAKE CHANGES TO SPECIFICATIONS AND PRODUCT DESCRIPTIONS AT ANY TIME WITHOUT NOTICE. NO LICENSE, WHETHER EXPRESS, IMPLIED, ARISING BY ESTOPPEL OR OTHERWISE, TO ANY INTELLECTUAL PROPERTY RIGHTS IS GRANTED BY THIS DOCUMENT.

TESTING AND OTHER QUALITY CONTROLS ARE USED TO THE EXTENT NATIONAL DEEMS NECESSARY TO SUPPORT NATIONAL'S PRODUCT WARRANTY. EXCEPT WHERE MANDATED BY GOVERNMENT REQUIREMENTS, TESTING OF ALL PARAMETERS OF EACH PRODUCT IS NOT NECESSARILY PERFORMED. NATIONAL ASSUMES NO LIABILITY FOR APPLICATIONS ASSISTANCE OR BUYER PRODUCT DESIGN. BUYERS ARE RESPONSIBLE FOR THEIR PRODUCTS AND APPLICATIONS USING NATIONAL COMPONENTS. PRIOR TO USING OR DISTRIBUTING ANY PRODUCTS THAT INCLUDE NATIONAL COMPONENTS, BUYERS SHOULD PROVIDE ADEQUATE DESIGN, TESTING AND OPERATING SAFEGUARDS.

EXCEPT AS PROVIDED IN NATIONAL'S TERMS AND CONDITIONS OF SALE FOR SUCH PRODUCTS, NATIONAL ASSUMES NO LIABILITY WHATSOEVER, AND NATIONAL DISCLAIMS ANY EXPRESS OR IMPLIED WARRANTY RELATING TO THE SALE AND/OR USE OF NATIONAL PRODUCTS INCLUDING LIABILITY OR WARRANTIES RELATING TO FITNESS FOR A PARTICULAR PURPOSE, MERCHANTABILITY, OR INFRINGEMENT OF ANY PATENT, COPYRIGHT OR OTHER INTELLECTUAL PROPERTY RIGHT.

### LIFE SUPPORT POLICY

**NATIONAL'S PRODUCTS ARE NOT AUTHORIZED FOR USE AS CRITICAL COMPONENTS IN LIFE SUPPORT DEVICES OR SYSTEMS WITHOUT THE EXPRESS PRIOR WRITTEN APPROVAL OF THE CHIEF EXECUTIVE OFFICER AND GENERAL COUNSEL OF NATIONAL SEMICONDUCTOR CORPORATION.** As used herein:

Life support devices or systems are devices which (a) are intended for surgical implant into the body, or (b) support or sustain life and whose failure to perform when properly used in accordance with instructions for use provided in the labeling can be reasonably expected to result in a significant injury to the user. A critical component is any component in a life support device or system whose failure to perform can be reasonably expected to cause the failure of the life support device or system or to affect its safety or effectiveness.

National Semiconductor and the National Semiconductor logo are registered trademarks of National Semiconductor Corporation. All other brand or product names may be trademarks or registered trademarks of their respective holders.

Copyright© 2009 National Semiconductor Corporation

For the most current product information visit us at [www.national.com](http://www.national.com)



**National Semiconductor  
Americas Technical  
Support Center**  
Email: [support@nsc.com](mailto:support@nsc.com)  
Tel: 1-800-272-9959

**National Semiconductor Europe  
Technical Support Center**  
Email: [europe.support@nsc.com](mailto:europe.support@nsc.com)

**National Semiconductor Asia  
Pacific Technical Support Center**  
Email: [ap.support@nsc.com](mailto:ap.support@nsc.com)

**National Semiconductor Japan  
Technical Support Center**  
Email: [jpn.feedback@nsc.com](mailto:jpn.feedback@nsc.com)

## IMPORTANT NOTICE

Texas Instruments Incorporated and its subsidiaries (TI) reserve the right to make corrections, modifications, enhancements, improvements, and other changes to its products and services at any time and to discontinue any product or service without notice. Customers should obtain the latest relevant information before placing orders and should verify that such information is current and complete. All products are sold subject to TI's terms and conditions of sale supplied at the time of order acknowledgment.

TI warrants performance of its hardware products to the specifications applicable at the time of sale in accordance with TI's standard warranty. Testing and other quality control techniques are used to the extent TI deems necessary to support this warranty. Except where mandated by government requirements, testing of all parameters of each product is not necessarily performed.

TI assumes no liability for applications assistance or customer product design. Customers are responsible for their products and applications using TI components. To minimize the risks associated with customer products and applications, customers should provide adequate design and operating safeguards.

TI does not warrant or represent that any license, either express or implied, is granted under any TI patent right, copyright, mask work right, or other TI intellectual property right relating to any combination, machine, or process in which TI products or services are used. Information published by TI regarding third-party products or services does not constitute a license from TI to use such products or services or a warranty or endorsement thereof. Use of such information may require a license from a third party under the patents or other intellectual property of the third party, or a license from TI under the patents or other intellectual property of TI.

Reproduction of TI information in TI data books or data sheets is permissible only if reproduction is without alteration and is accompanied by all associated warranties, conditions, limitations, and notices. Reproduction of this information with alteration is an unfair and deceptive business practice. TI is not responsible or liable for such altered documentation. Information of third parties may be subject to additional restrictions.

Resale of TI products or services with statements different from or beyond the parameters stated by TI for that product or service voids all express and any implied warranties for the associated TI product or service and is an unfair and deceptive business practice. TI is not responsible or liable for any such statements.

TI products are not authorized for use in safety-critical applications (such as life support) where a failure of the TI product would reasonably be expected to cause severe personal injury or death, unless officers of the parties have executed an agreement specifically governing such use. Buyers represent that they have all necessary expertise in the safety and regulatory ramifications of their applications, and acknowledge and agree that they are solely responsible for all legal, regulatory and safety-related requirements concerning their products and any use of TI products in such safety-critical applications, notwithstanding any applications-related information or support that may be provided by TI. Further, Buyers must fully indemnify TI and its representatives against any damages arising out of the use of TI products in such safety-critical applications.

TI products are neither designed nor intended for use in military/aerospace applications or environments unless the TI products are specifically designated by TI as military-grade or "enhanced plastic." Only products designated by TI as military-grade meet military specifications. Buyers acknowledge and agree that any such use of TI products which TI has not designated as military-grade is solely at the Buyer's risk, and that they are solely responsible for compliance with all legal and regulatory requirements in connection with such use.

TI products are neither designed nor intended for use in automotive applications or environments unless the specific TI products are designated by TI as compliant with ISO/TS 16949 requirements. Buyers acknowledge and agree that, if they use any non-designated products in automotive applications, TI will not be responsible for any failure to meet such requirements.

Following are URLs where you can obtain information on other Texas Instruments products and application solutions:

### Products

Audio	<a href="http://www.ti.com/audio">www.ti.com/audio</a>
Amplifiers	<a href="http://amplifier.ti.com">amplifier.ti.com</a>
Data Converters	<a href="http://dataconverter.ti.com">dataconverter.ti.com</a>
DLP® Products	<a href="http://www.dlp.com">www.dlp.com</a>
DSP	<a href="http://dsp.ti.com">dsp.ti.com</a>
Clocks and Timers	<a href="http://www.ti.com/clocks">www.ti.com/clocks</a>
Interface	<a href="http://interface.ti.com">interface.ti.com</a>
Logic	<a href="http://logic.ti.com">logic.ti.com</a>
Power Mgmt	<a href="http://power.ti.com">power.ti.com</a>
Microcontrollers	<a href="http://microcontroller.ti.com">microcontroller.ti.com</a>
RFID	<a href="http://www.ti-rfid.com">www.ti-rfid.com</a>
OMAP Mobile Processors	<a href="http://www.ti.com/omap">www.ti.com/omap</a>
Wireless Connectivity	<a href="http://www.ti.com/wirelessconnectivity">www.ti.com/wirelessconnectivity</a>

### Applications

Communications and Telecom	<a href="http://www.ti.com/communications">www.ti.com/communications</a>
Computers and Peripherals	<a href="http://www.ti.com/computers">www.ti.com/computers</a>
Consumer Electronics	<a href="http://www.ti.com/consumer-apps">www.ti.com/consumer-apps</a>
Energy and Lighting	<a href="http://www.ti.com/energy">www.ti.com/energy</a>
Industrial	<a href="http://www.ti.com/industrial">www.ti.com/industrial</a>
Medical	<a href="http://www.ti.com/medical">www.ti.com/medical</a>
Security	<a href="http://www.ti.com/security">www.ti.com/security</a>
Space, Avionics and Defense	<a href="http://www.ti.com/space-avionics-defense">www.ti.com/space-avionics-defense</a>
Transportation and Automotive	<a href="http://www.ti.com/automotive">www.ti.com/automotive</a>
Video and Imaging	<a href="http://www.ti.com/video">www.ti.com/video</a>

TI E2E Community Home Page

[e2e.ti.com](http://e2e.ti.com)

Mailing Address: Texas Instruments, Post Office Box 655303, Dallas, Texas 75265  
Copyright © 2011, Texas Instruments Incorporated