



LOW POWER QUAD OPERATIONAL AMPLIFIER

- WIDE GAIN BANDWIDTH: 1.3MHz
- INPUT COMMON-MODE VOLTAGE RANGE INCLUDES GROUND
- LARGE VOLTAGE GAIN: 100dB
- VERY LOW SUPPLY CURRENT/AMPLI: 375µA
- LOW INPUT BIAS CURRENT: 20nA
- LOW INPUT OFFSET CURRENT: 2nA
- WIDE POWER SUPPLY RANGE:
SINGLE SUPPLY: +3V TO +30V
DUAL SUPPLIES: ±1.5V TO ±15V
- ESD INTERNAL PROTECTION : 2kV

DESCRIPTION

This circuit consists of four independent, high gain, internally frequency compensated operational amplifiers which were designed specially for automotive and industrial control systems. It operates from a single power supply over a wide range of voltages. Operation from split power supplies is also possible. All the pins are protected against electrostatic discharges up to 2000v.

ORDER CODE

Part Number	Temperature Range	Package		
		N	D	P
LM2902W	-40°C, +125°C	•	•	•

N = Dual in Line Package (DIP)
D = Small Outline Package (SO) - also available in Tape & Reel (DT)
P = Thin Shrink Small Outline Package (TSSOP) - only available in Tape & Reel (PT)

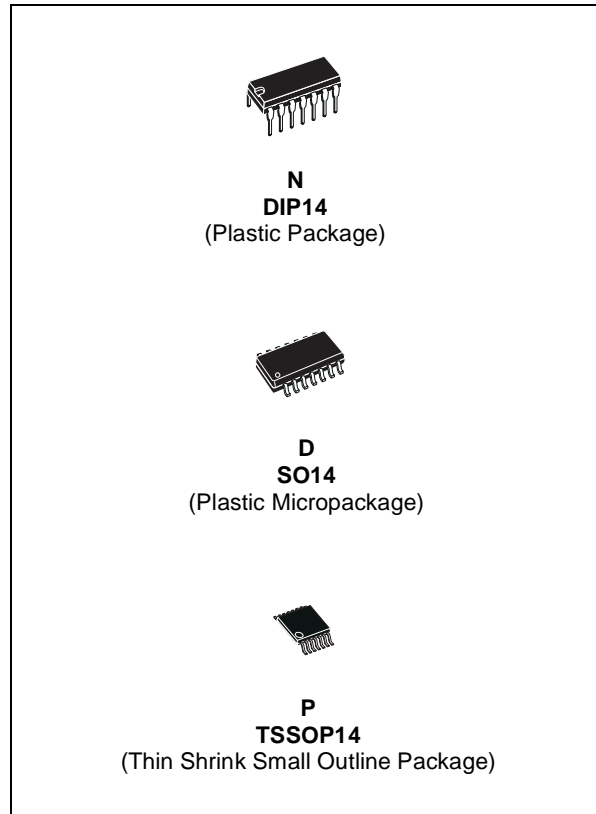

PIN CONNECTIONS (top view)

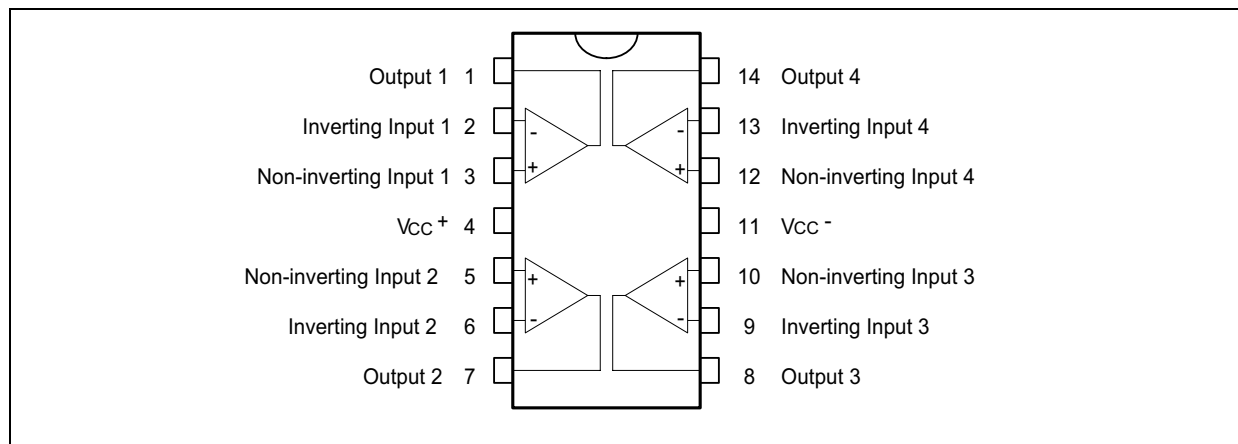

SCHMATIC DIAGRAM (1/4 LM2902)

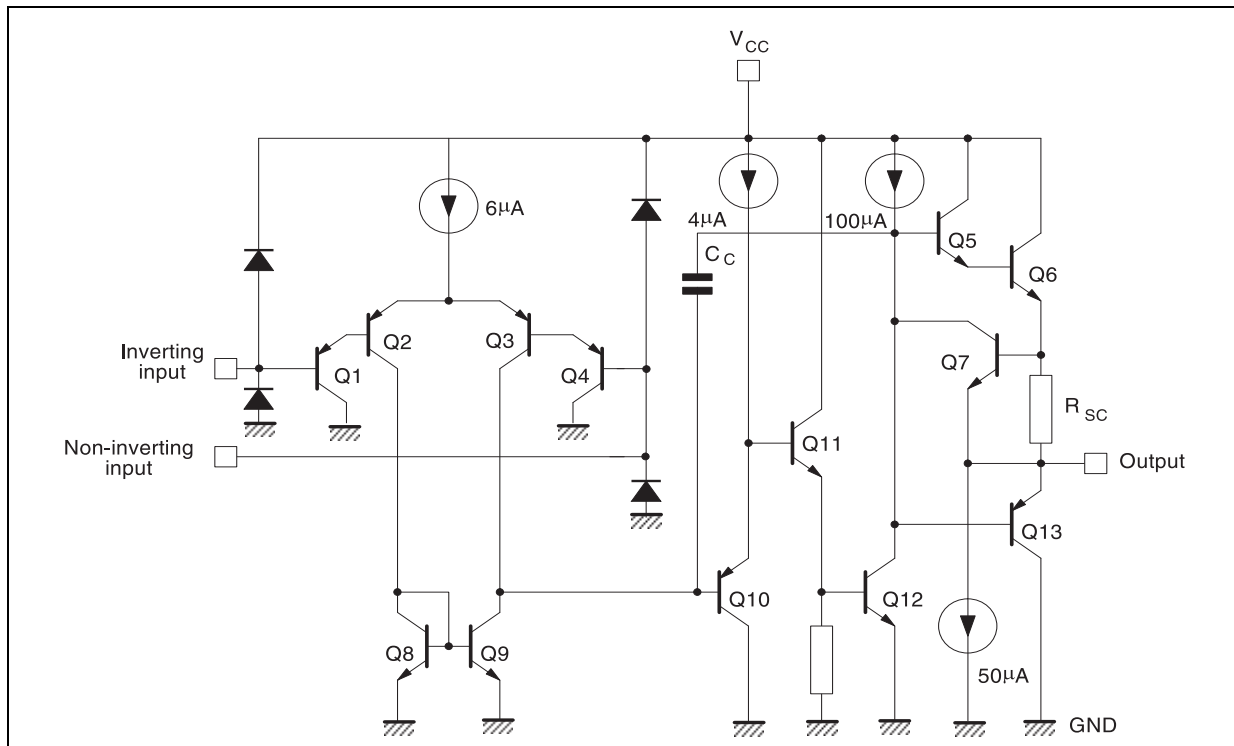

ABSOLUTE MAXIMUM RATINGS

Symbol	Parameter	Value	Unit
V_{CC}	Supply Voltage	± 16 to 32	V
V_{id}	Differential Input Voltage	-0.3 to $V_{CC} + 0.3$	V
V_i	Input Voltage	-0.3 to $V_{CC} + 0.3$	V
	Output Short-circuit to Ground ¹⁾	Infinite	
P_{tot}	Power Dissipation N Suffix D Suffix	500 400	mW
I_{in}	Input Current ²⁾	50	mA
T_{oper}	Operating Free-Air Temperature Range	-40 to +125	°C
T_{stg}	Storage Temperature Range	-65 to +150	°C

1. Short-circuit from the output to V_{CC} can cause excessive heating if $V_{CC} > 15V$. The maximum output current is approximately 40mA independent of the magnitude of V_{CC} . Destructive dissipation can result from simultaneous short-circuit on all amplifiers.
2. This input current only exists when the voltage at any of the input leads is driven negative. It is due to the collector-base junction of the input PNP transistor becoming forward biased and thereby acting as input diodes clamps. In addition to this diode action, there is also NPN parasitic action on the IC chip. This transistor action can cause the output voltages of the Op-Amps to go to the V_{CC} voltage level (or to ground for a large overdrive) for the time duration than an input is driven negative. This is not destructive and normal output will set up again for input voltage higher than -0.3V.

ELECTRICAL CHARACTERISTICS
 $V_{CC}^+ = 5V$, $V_{CC}^- = \text{Ground}$, $V_O = 1.4V$, $T_{amb} = 25^\circ\text{C}$ (unless otherwise specified)

Symbol	Parameter	Min.	Typ.	Max.	Unit
V_{io}	Input Offset Voltage ¹⁾ $T_{amb} = +25^\circ\text{C}$ $T_{min} \leq T_{amb} \leq T_{max}$.		2	7 9	mV
I_{io}	Input Offset Current $T_{amb} = +25^\circ\text{C}$ $T_{min} \leq T_{amb} \leq T_{max}$.		2	30 40	nA
I_{ib}	Input Bias Current ²⁾ $T_{amb} = +25^\circ\text{C}$ $T_{min} \leq T_{amb} \leq T_{max}$.		20	150 300	nA
A_{vd}	Large Signal Voltage Gain $V_{CC}^+ = +15V, R_L = 2k\Omega, V_O = 1.4V \text{ to } 11.4V$ $T_{amb} = +25^\circ\text{C}$ $T_{min} \leq T_{amb} \leq T_{max}$.	50 25	100		V/mV
SVR	Supply Voltage Rejection Ratio ($R_S \leq 10k\Omega$) $T_{amb} = +25^\circ\text{C}$ $T_{min} \leq T_{amb} \leq T_{max}$.	65 65	110		dB
I_{CC}	Supply Current, all Amp, no load $T_{amb} = +25^\circ\text{C}$ $T_{min} \leq T_{amb} \leq T_{max}$.		$V_{CC} = +5V$ 0.7 $V_{CC} = +30V$ 1.5 $V_{CC} = +5V$ 0.8 $V_{CC} = +30V$ 1.5	1.2 3 1.2 3	mA
V_{icm}	Input Common Mode Voltage Range ($V_{CC} = +30V$) ³⁾ $T_{amb} = +25^\circ\text{C}$ $T_{min} \leq T_{amb} \leq T_{max}$.	0 0		$V_{CC} - 1.5$ $V_{CC} - 2$	V
CMR	Common-mode Rejection Ratio ($R_S \leq 10k\Omega$) $T_{amb} = +25^\circ\text{C}$ $T_{min} \leq T_{amb} \leq T_{max}$.	70 60	80		dB
I_O	Output Short-circuit Current ($V_{id} = +1V$) $V_{CC} = +15V, V_O = +2V$	20	40	70	mA
I_{sink}	Output Sink Current ($V_{id} = -1V$) $V_{CC} = +15V, V_O = +2V$ $V_{CC} = +15V, V_O = +0.2V$	10 12	20 50		mA μA
V_{OH}	High Level Output Voltage ($V_{CC} = +30V$) $T_{amb} = +25^\circ\text{C}$ $T_{min} \leq T_{amb} \leq T_{max}$. $T_{amb} = +25^\circ\text{C}$ $T_{min} \leq T_{amb} \leq T_{max}$. $(V_{CC} + 5V), R_L = 2k\Omega$ $T_{min} \leq T_{amb} \leq T_{max}$. $T_{amb} = +25^\circ\text{C}$	26 26 27 27 3.5 3	27 28		V
V_{OL}	Low Level Output Voltage ($R_L = 10k\Omega$) $T_{amb} = +25^\circ\text{C}$ $T_{min} \leq T_{amb} \leq T_{max}$		5	20 20	mV
SR	Slew Rate $V_{CC} = 15V, V_i = 0.5 \text{ to } 3V, R_L = 2k\Omega, C_L = 100pF,$ unity gain		0.4		V/ μs

LM2902W

Symbol	Parameter	Min.	Typ.	Max.	Unit
GBP	Gain Bandwidth Product $V_{CC} = 30V, V_{in} = 10mV, R_L = 2k\Omega, C_L = 100pF$		1.3		MHz
THD	Total Harmonic Distortion $f = 1kHz, A_V = 20dB, R_L = 2k\Omega, V_o = 2V_{pp}, C_L = 100pF, V_{CC} = 30V$		0.015		%
e_n	Equivalent Input Noise Voltage $f = 1kHz, R_S = 100\Omega, V_{CC} = 30V$		40		$\frac{nV}{\sqrt{Hz}}$
DV_{io}	Input Offset Voltage Drift		7	30	$\mu V/^\circ C$
DI_{io}	Input Offset Current Drift		10	200	$pA/^\circ C$
V_{O1}/V_{O2}	Channel Separation ⁴⁾ $1kHz \leq f \leq 20kHz$		120		dB

- $V_O = 1.4V, R_S = 0\Omega, 5V < V_{CC} < 30V, 0V < V_{ic} < V_{CC} - 1.5V$
- The direction of the input current is out of the IC. This current is essentially constant, independent of the state of the output, so no loading charge change exists on the input lines
- The input common-mode voltage of either input signal voltage should not be allowed to go negative by more than 0.3V. The upper end of the common-mode voltage range is $V_{CC} - 1.5V$, but either or both inputs can go to +32V without damage.
- Due to the proximity of external components insure that coupling is not originating via stray capacitance between these external parts. This typically can be detected as this type of capacitance increases at higher frequencies.

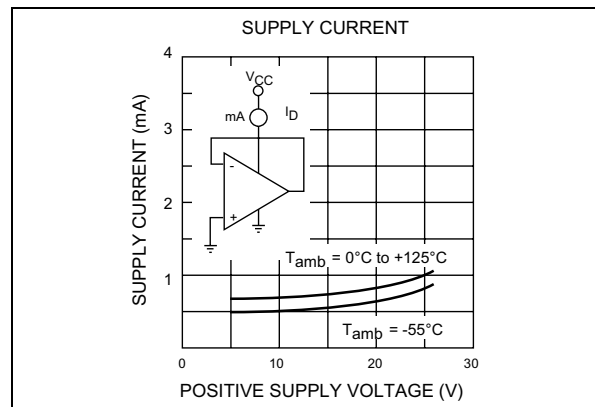
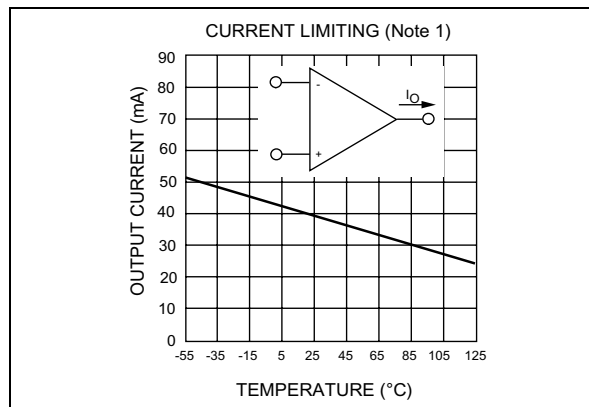
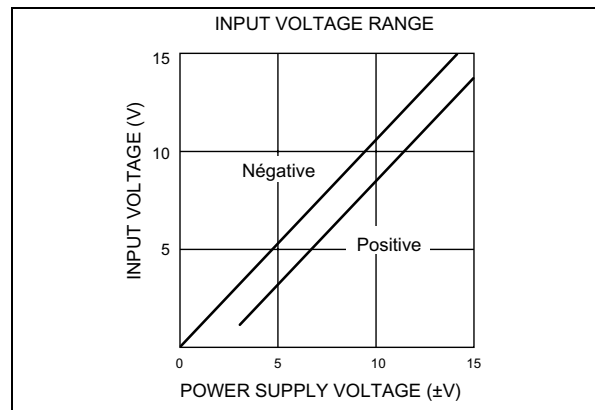
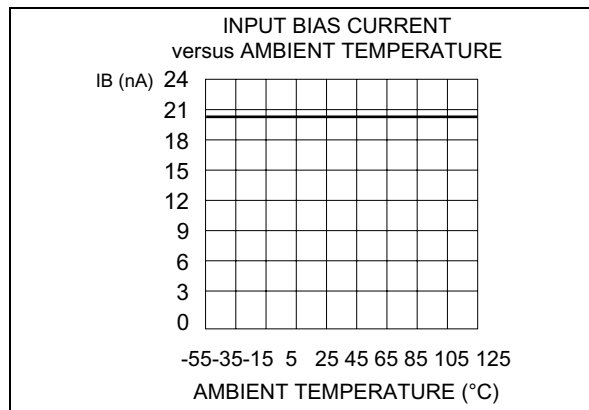

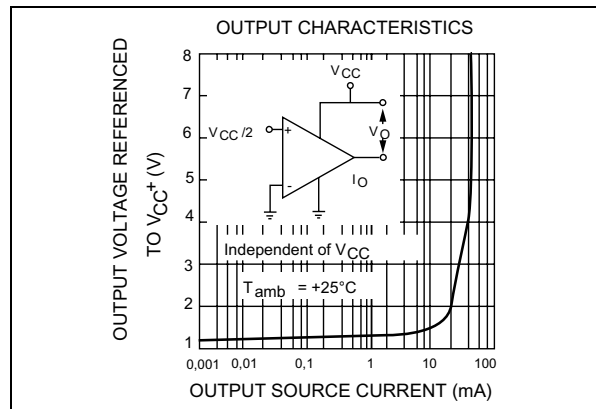
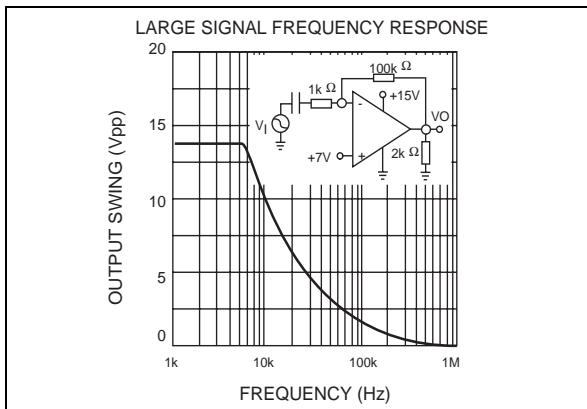
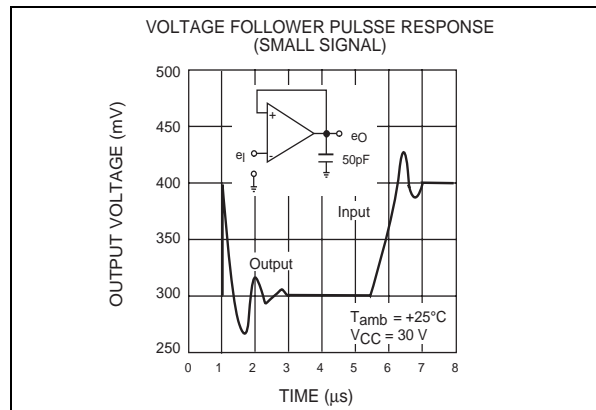
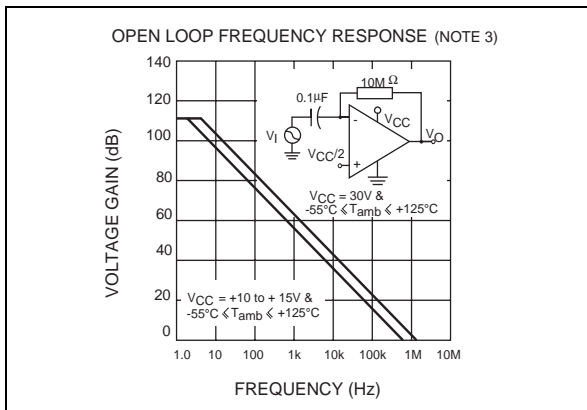
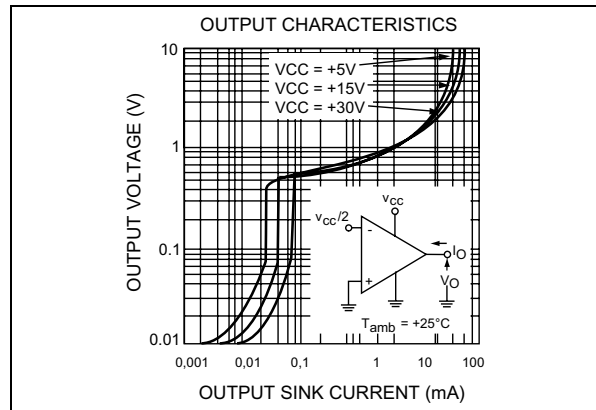
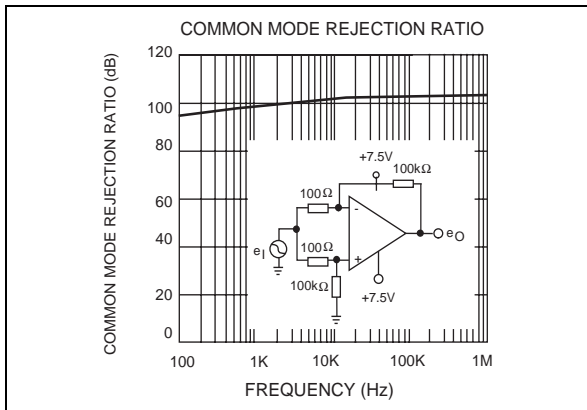
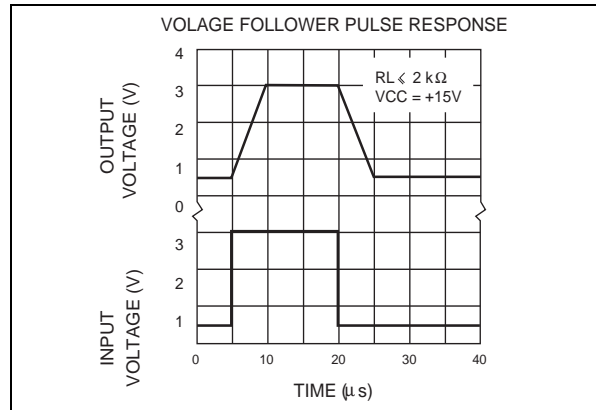
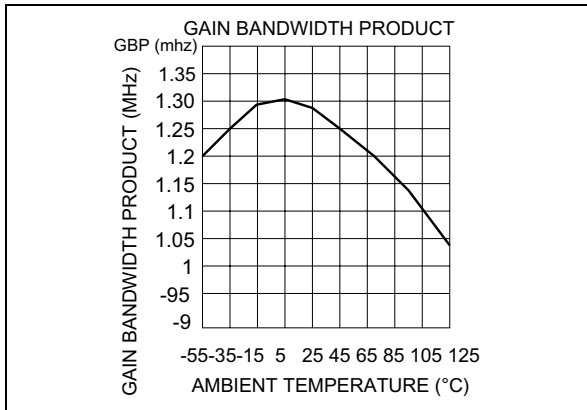

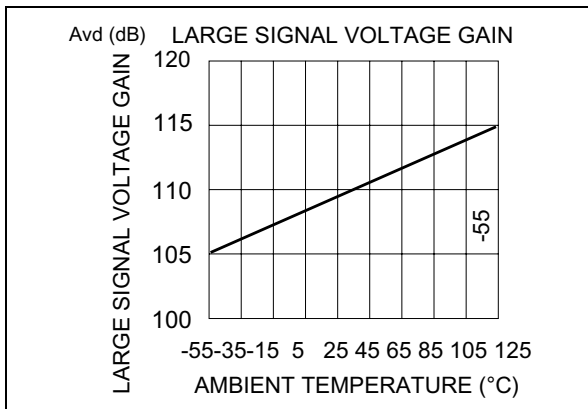
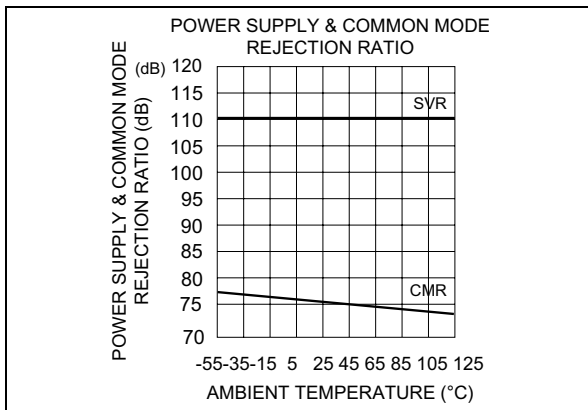
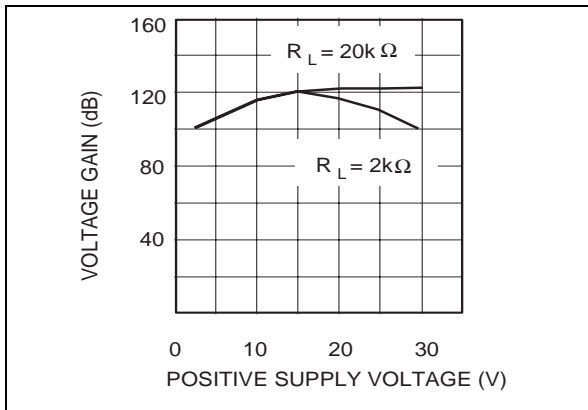
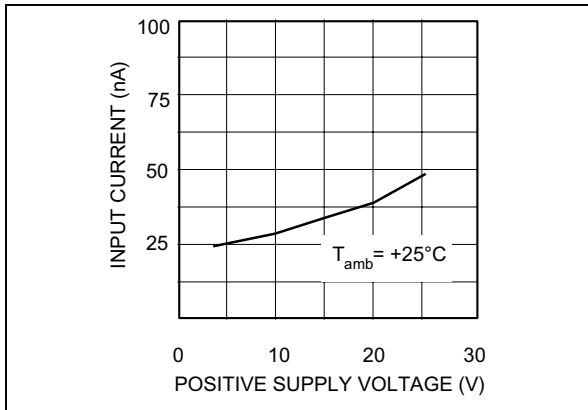

TYPICAL SINGLE - SUPPLY APPLICATIONS
AC COUPLED INVERTING AMPLIFIER

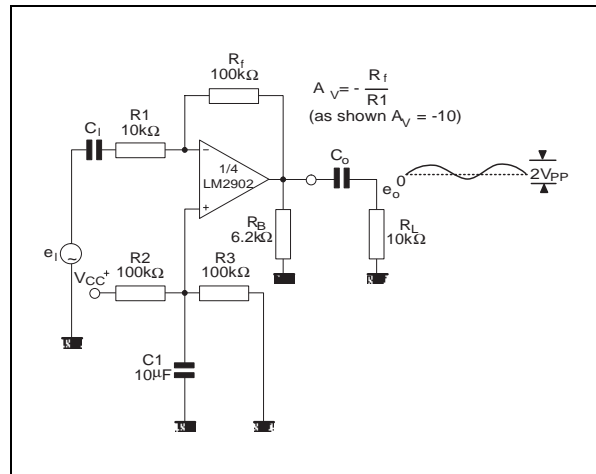

AC COUPLED NON-INVERTING AMPLIFIER

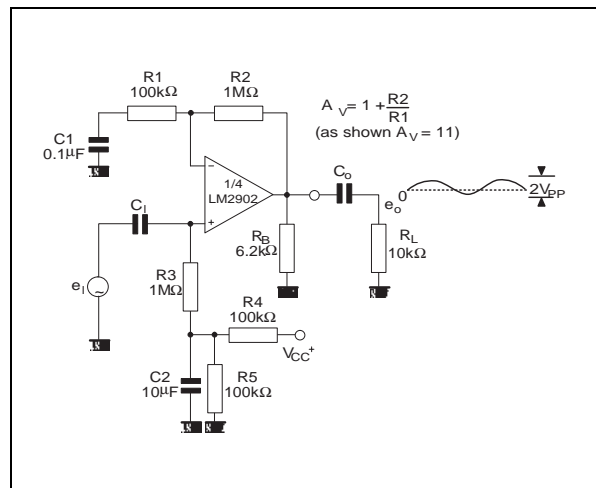

NON-INVERTING DC GAIN

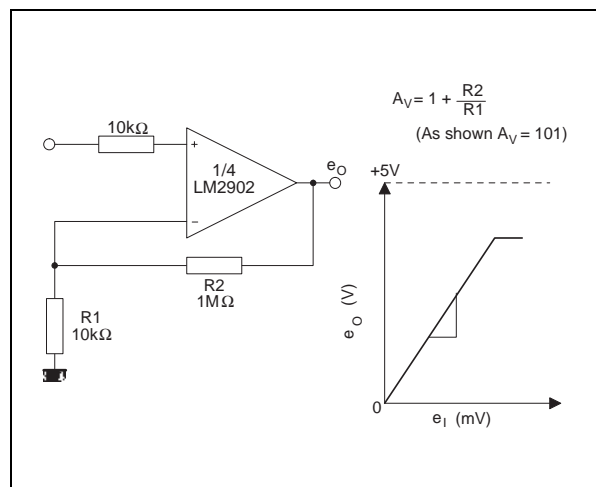

DC SUMMING AMPLIFIER

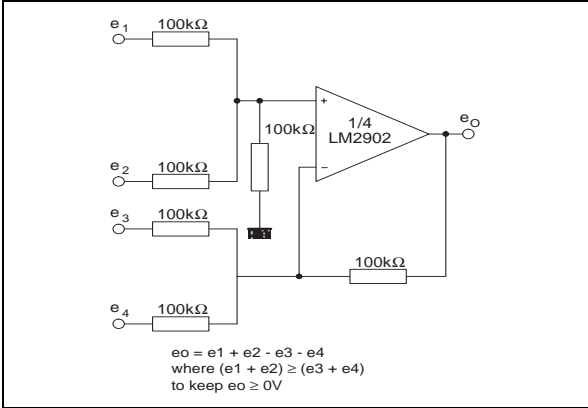

ACTIVER BADPASS FILTER

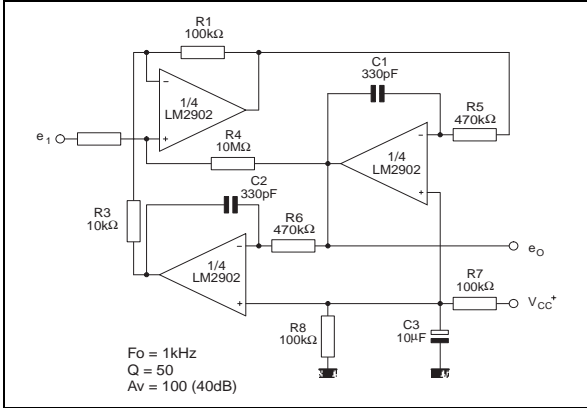

HIGH INPUT Z ADJUSTABLE GAIN DC INSTRUMENTATION AMPLIFIER

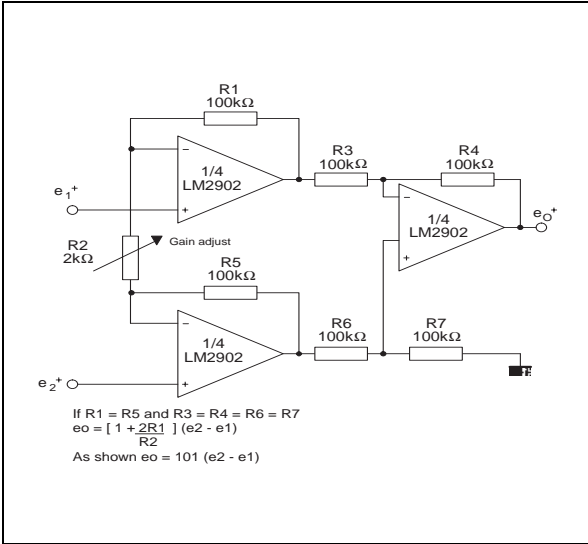

HIGH INPUT Z, DC DIFFERENTIAL AMPLIFIER

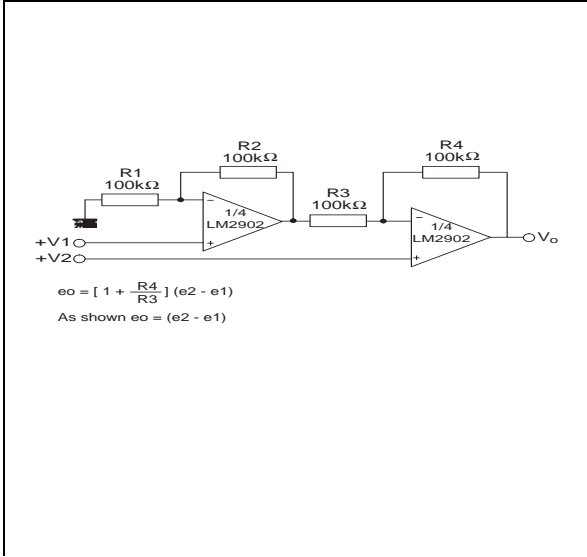

LOW DRIFT PEAK DETECTOR

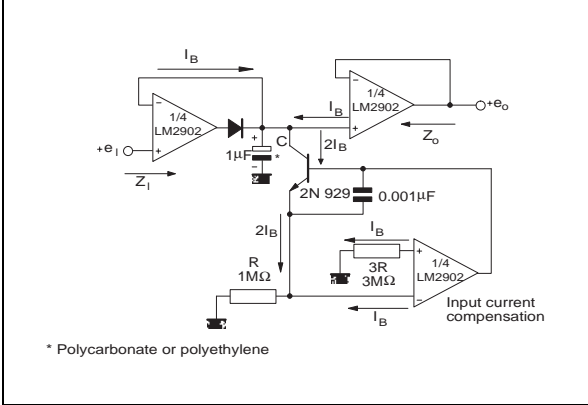

USING SYMMETRICAL AMPLIFIERS TO REDUCE INPUT CURRENT (GENERAL CONCEPT)

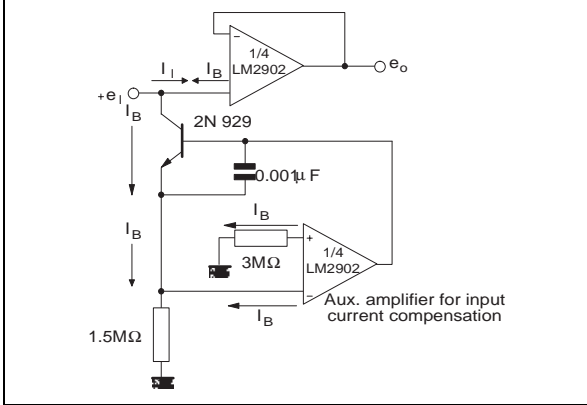

PACKAGE MECHANICAL DATA

Plastic DIP-14 MECHANICAL DATA

DIM.	mm.			inch		
	MIN.	TYP	MAX.	MIN.	TYP.	MAX.
a1	0.51			0.020		
B	1.39		1.65	0.055		0.065
b		0.5			0.020	
b1		0.25			0.010	
D			20			0.787
E		8.5			0.335	
e		2.54			0.100	
e3		15.24			0.600	
F			7.1			0.280
l			5.1			0.201
L		3.3			0.130	
Z	1.27		2.54	0.050		0.100

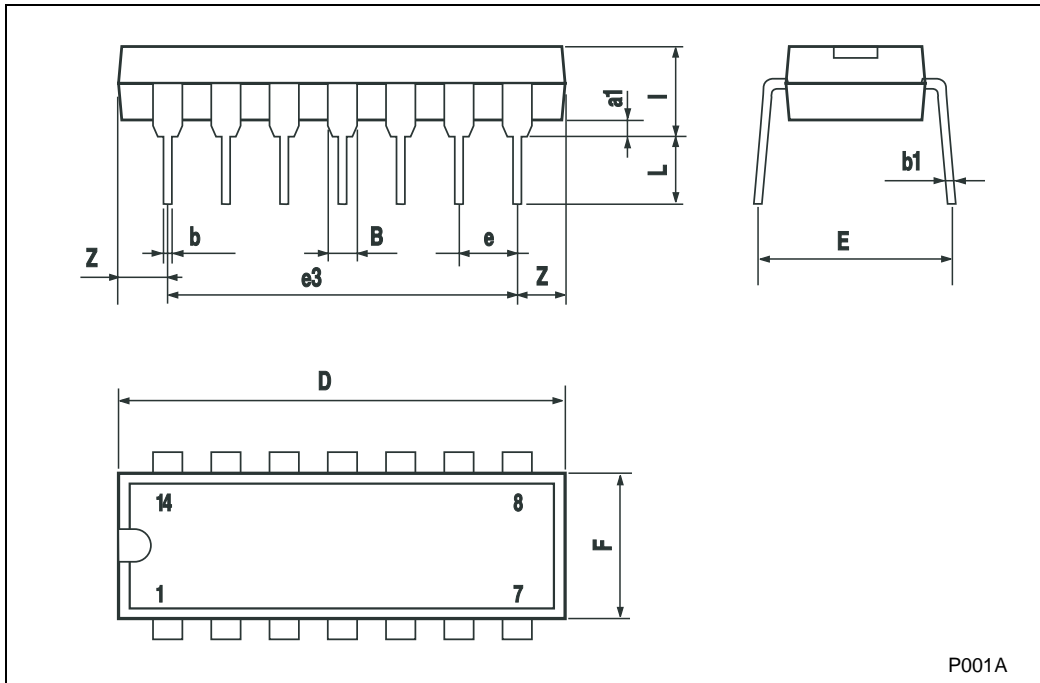

PACKAGE MECHANICAL DATA

SO-14 MECHANICAL DATA

DIM.	mm.			inch		
	MIN.	TYP.	MAX.	MIN.	TYP.	MAX.
A			1.75			0.068
a1	0.1		0.2	0.003		0.007
a2			1.65			0.064
b	0.35		0.46	0.013		0.018
b1	0.19		0.25	0.007		0.010
C		0.5			0.019	
c1	45° (typ.)					
D	8.55		8.75	0.336		0.344
E	5.8		6.2	0.228		0.244
e		1.27			0.050	
e3		7.62			0.300	
F	3.8		4.0	0.149		0.157
G	4.6		5.3	0.181		0.208
L	0.5		1.27	0.019		0.050
M			0.68			0.026
S	8° (max.)					

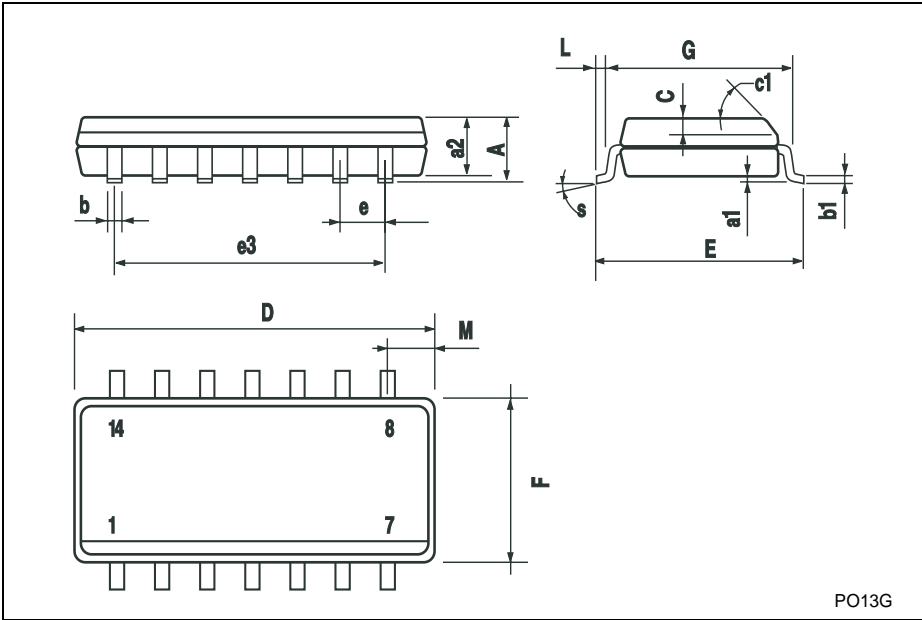

PO13G

PACKAGE MECHANICAL DATA

TSSOP14 MECHANICAL DATA						
DIM.	mm.			inch		
	MIN.	TYP.	MAX.	MIN.	TYP.	MAX.
A			1.2			0.047
A1	0.05		0.15	0.002	0.004	0.006
A2	0.8	1	1.05	0.031	0.039	0.041
b	0.19		0.30	0.007		0.012
c	0.09		0.20	0.004		0.0089
D	4.9	5	5.1	0.193	0.197	0.201
E	6.2	6.4	6.6	0.244	0.252	0.260
E1	4.3	4.4	4.48	0.169	0.173	0.176
e		0.65 BSC			0.0256 BSC	
K	0°		8°	0°		8°
L	0.45	0.60	0.75	0.018	0.024	0.030

0080337D

Information furnished is believed to be accurate and reliable. However, STMicroelectronics assumes no responsibility for the consequences of use of such information nor for any infringement of patents or other rights of third parties which may result from its use. No license is granted by implication or otherwise under any patent or patent rights of STMicroelectronics. Specifications mentioned in this publication are subject to change without notice. This publication supersedes and replaces all information previously supplied. STMicroelectronics products are not authorized for use as critical components in life support devices or systems without express written approval of STMicroelectronics.

© The ST logo is a registered trademark of STMicroelectronics

© 2001 STMicroelectronics - Printed in Italy - All Rights Reserved
 STMicroelectronics GROUP OF COMPANIES

Australia - Brazil - Canada - China - Finland - France - Germany - Hong Kong - India - Israel - Italy - Japan - Malaysia
 Malta - Morocco - Singapore - Spain - Sweden - Switzerland - United Kingdom - United States

© <http://www.st.com>