

Low power quad voltage comparator

Features

- Wide single supply voltage range or dual supplies for all devices: +2V to +36V or $\pm 1V$ to $\pm 18V$
- Very low supply current (1.1mA) independent of supply voltage (1.4mW/comparator at +5V)
- Low input bias current: 25nA typ.
- Low input offset current: $\pm 5nA$ typ.
- Input common-mode voltage range includes negative rail
- Low output saturation voltage: 250mV typ. ($I_O = 4mA$)
- Differential input voltage range equal to the supply voltage
- TTL, DTL, ECL, MOS, CMOS compatible outputs

Description

This device consists of four independent precision voltage comparators. All these comparators are designed specifically to operate from a single supply over a wide range of voltages. Operation from split power supplies is also possible.

These comparators also have a unique characteristic in that the input common-mode voltage range includes the negative rail even though operated from a single power supply voltage.

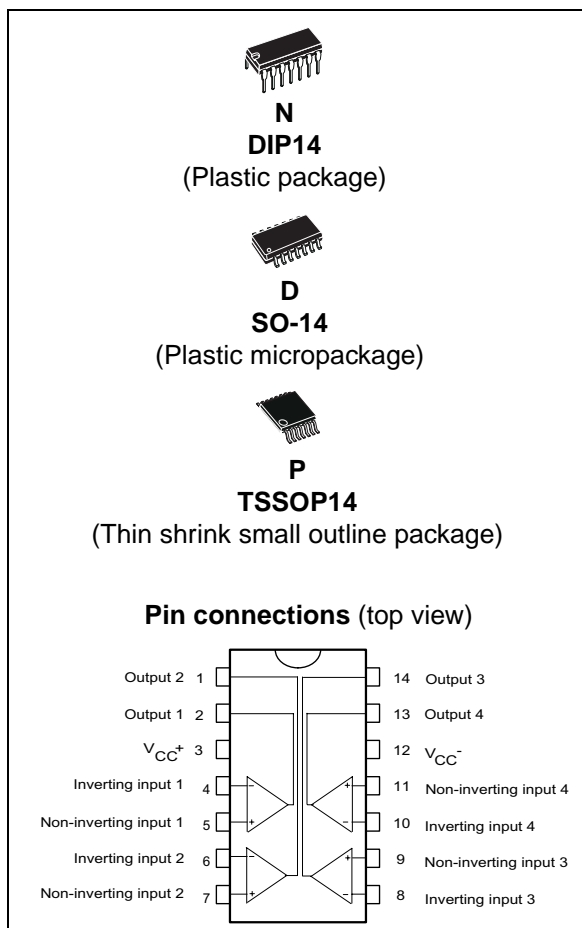

1 Schematic diagram

Figure 1. Schematic diagram (1/4 LM2901)

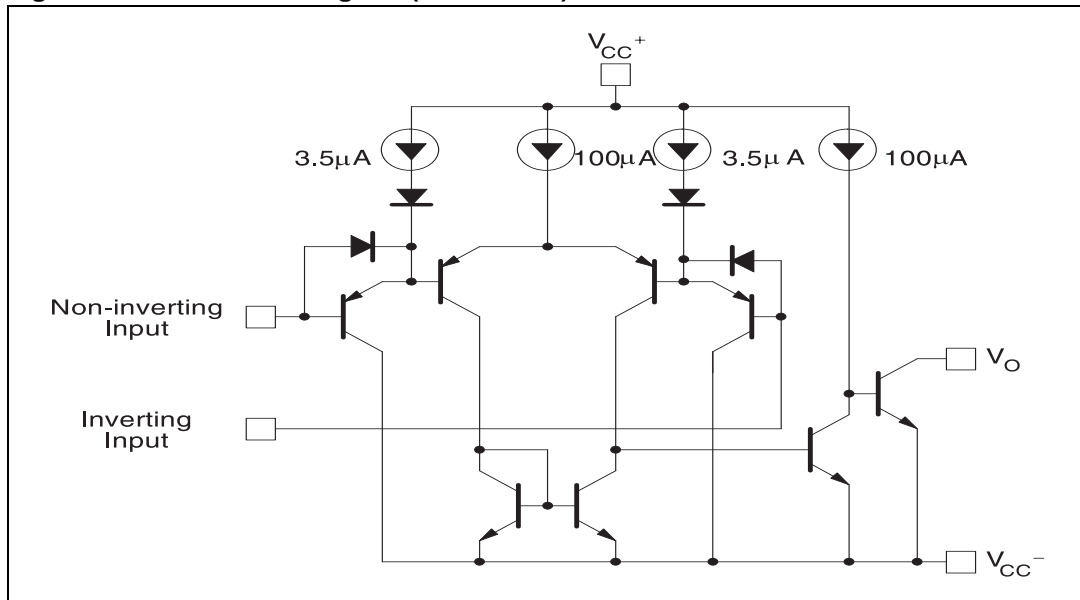

2 Absolute maximum ratings and operating conditions

Table 1. Absolute maximum ratings

Symbol	Parameter	Value	Unit
V_{CC}	Supply voltage	± 18 to 36	V
V_{id}	Differential input voltage	± 36	V
V_{in}	Input voltage	-0.3 to +36	V
	Output short-circuit to ground ⁽¹⁾		
R_{thja}	Thermal resistance junction to ambient ⁽²⁾		°C/W
	DIP14	80	
	SO-14 TSSOP14	105 100	
R_{thjc}	Thermal resistance junction to case ⁽²⁾		
	DIP14	33	
	SO-14 TSSOP14	31 32	
T_j	Maximum junction temperature	+150	°C
T_{stg}	Storage temperature range	-65 to +150	°C
ESD	HBM: human body model ⁽³⁾	500	V
	MM: machine model ⁽⁴⁾	100	V
	CDM: charged device model ⁽⁵⁾	1500	V

- Short-circuits from the output to V_{CC}^+ can cause excessive heating and eventual destruction. The maximum output current is approximately 20mA, independent of the magnitude of V_{CC}^+ .
- Short-circuits can cause excessive heating. Destructive dissipation can result from simultaneous short-circuits on all amplifiers. All values are typical.
- Human body model: A 100pF capacitor is charged to the specified voltage, then discharged through a 1.5k Ω resistor between two pins of the device. This is done for all couples of connected pin combinations while the other pins are floating.
- Machine model: A 200pF capacitor is charged to the specified voltage, then discharged directly between two pins of the device with no external series resistor (internal resistor < 5 Ω). This is done for all couples of connected pin combinations while the other pins are floating.
- Charged device model: all pins and the package are charged together to the specified voltage and then discharged directly to the ground through only one pin. This is done for all pins.

Table 2. Operating conditions

Symbol	Parameter	Value	Unit
V_{CC}	Supply voltage	2 to 32 ± 1 to ± 16	V
V_{icm}	Common mode input voltage range $T_{min} \leq T_{amb} \leq T_{max}$	0 to ($V_{CC}^+ - 1.5$) 0 to ($V_{CC}^+ - 2$)	V
T_{oper}	Operating free-air temperature range	-40 to +125	°C

3 Electrical characteristics

Table 3. Electrical characteristics at $V_{CC}^+ = 5V$, $V_{CC}^- = GND$, $T_{amb} = 25^\circ C$ (unless otherwise specified)

Symbol	Parameter	Min.	Typ.	Max.	Unit
V_{io}	Input offset voltage ⁽¹⁾ $T_{min} \leq T_{amb} \leq T_{max}$		1	7 15	mV
I_{io}	Input offset current $T_{min} \leq T_{amb} \leq T_{max}$		5	50 150	nA
I_{ib}	Input bias current (I_{I^+} or I_{I^-}) ⁽²⁾ $T_{min} \leq T_{amb} \leq T_{max}$		25	250 400	nA
A_{vd}	Large signal voltage gain ($V_{CC} = 15V, R_L = 15k\Omega, V_o = 1$ to $11V$)	25	200		V/mV
I_{CC}	Supply current (all comparators) $V_{CC} = +5V$, no load $V_{CC} = +30V$, no load		1.1 1.3	2 2.5	mA
V_{id}	Differential input voltage ⁽³⁾			V_{CC}^+	V
V_{OL}	Low level output voltage $V_{id} = -1V, I_{sink} = 4mA$ $T_{min} \leq T_{amb} \leq T_{max}$		250	400 700	mV
I_{OH}	High level output current ($V_{CC} = V_o = 30V, V_{id} = 1V$) $T_{min} \leq T_{amb} \leq T_{max}$		0.1	1	nA μA
I_{sink}	Output sink current ($V_{id} = -1V, V_o = 1.5V$)	6	16		mA
t_{res}	Small signal response time ⁽⁴⁾ ($R_L = 5.1k\Omega$ connected to V_{CC}^+)		1.3		μs
t_{rel}	Large signal response time ⁽⁵⁾ TTL input ($V_{ref} = +1.4V, R_L = 5.1k\Omega$ to V_{CC}^+) Output signal at 50% of final value Output signal at 95% of final value			500 1	ns μs

1. At output switch point, $V_o \approx 1.4V$, $R_S = 0$ with V_{CC}^+ from 5V to 30V, and over the full input common-mode range (0V to $V_{CC}^+ - 1.5V$).
2. The direction of the input current is out of the IC due to the PNP input stage. This current is essentially constant, independent of the state of the output, so there is no loading charge on the reference of input lines.
3. The response time specified is for a 100mV input step with 5mV overdrive.
4. Positive excursions of input voltage may exceed the power supply level. As long as the other voltage remains within the common-mode range, the comparator will provide a proper output state. The low input voltage state must not be less than $-0.3V$ (or $0.3V$ below the negative power supply, if used).
5. Maximum values are guaranteed by design.

Figure 2. Supply current vs. supply voltage

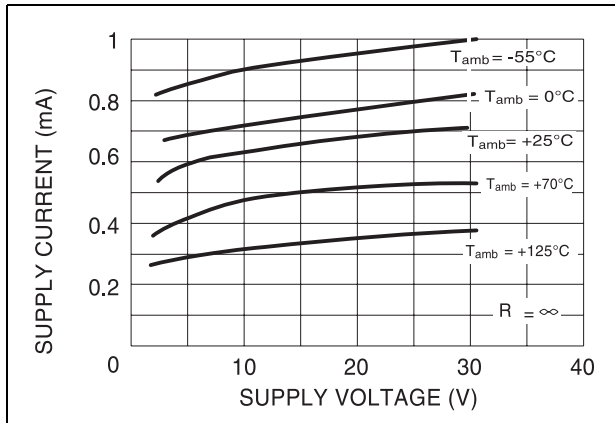

Figure 3. Input current vs. supply voltage

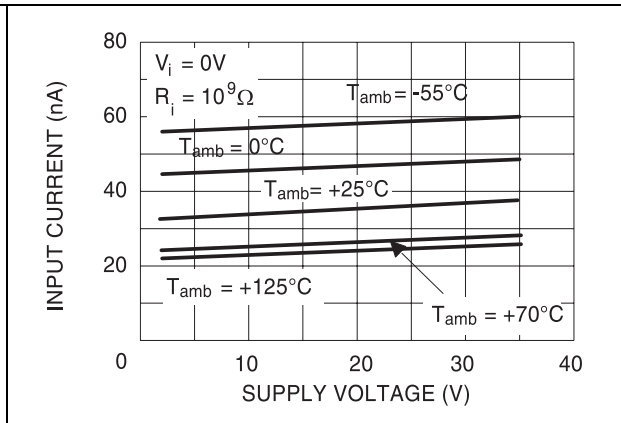

Figure 4. Output saturation voltage vs. output current

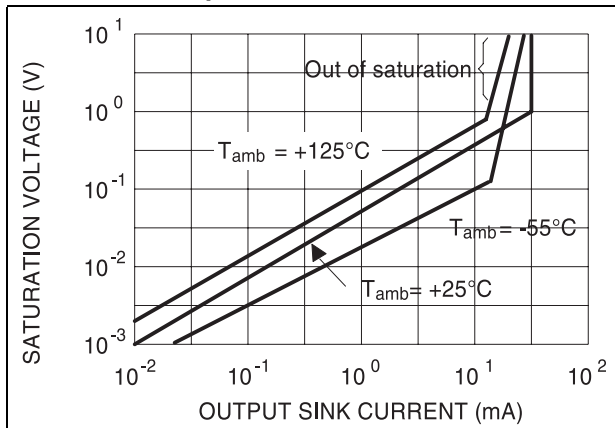

Figure 5. Response time for various input overdrives - negative transition

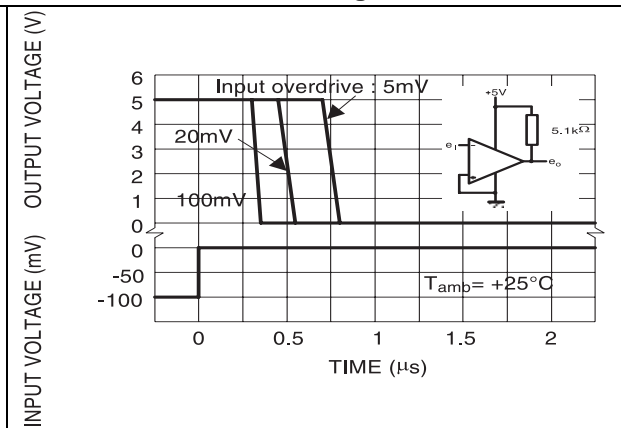
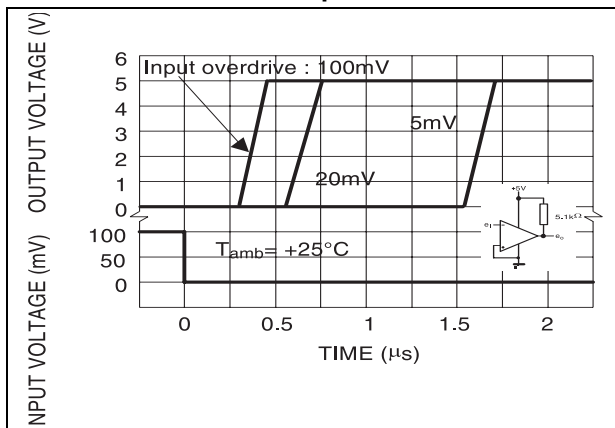

Figure 6. Response time for various input overdrives - positive transition



4 Typical applications schematics

Figure 7. Basic comparator

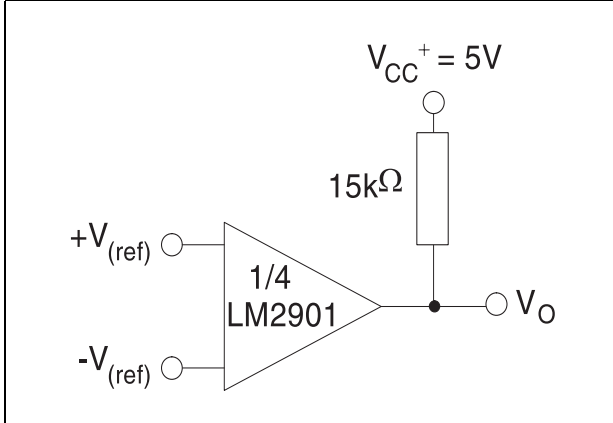

Figure 8. Driving CMOS

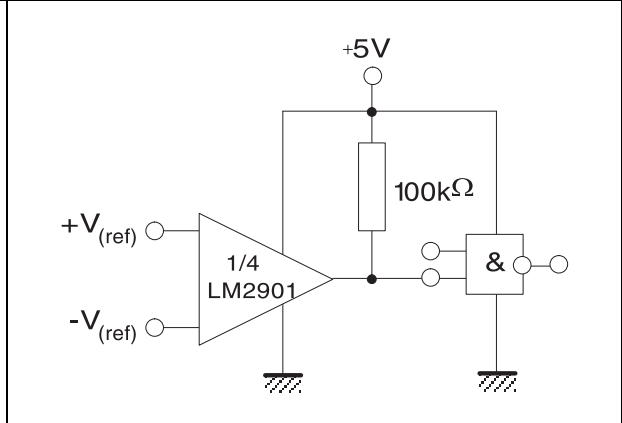

Figure 9. Driving TTL

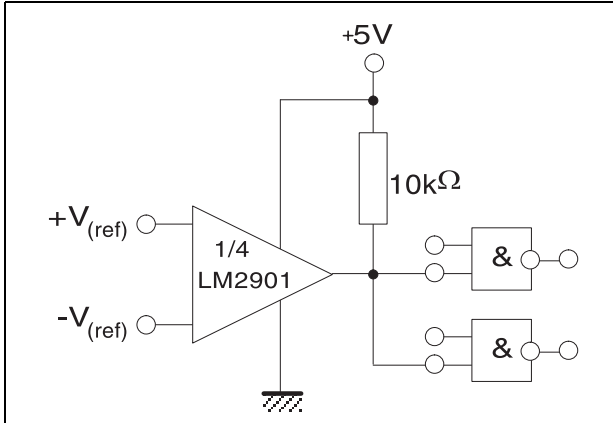

Figure 10. Low frequency op-amp

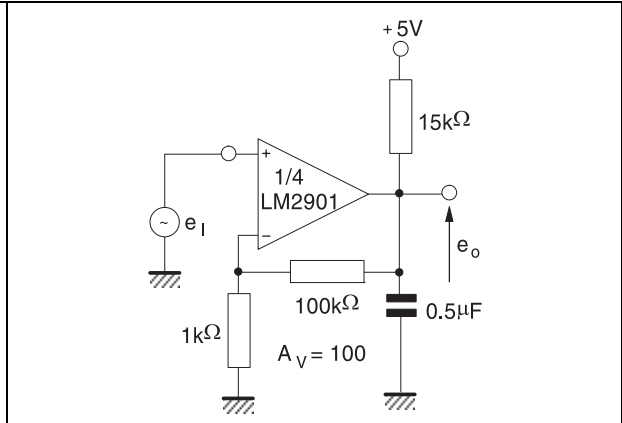

Figure 11. Low frequency op-amp

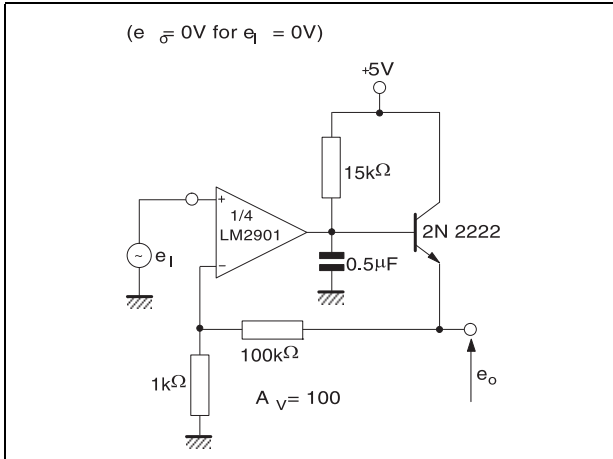

Figure 12. Transducer amplifier

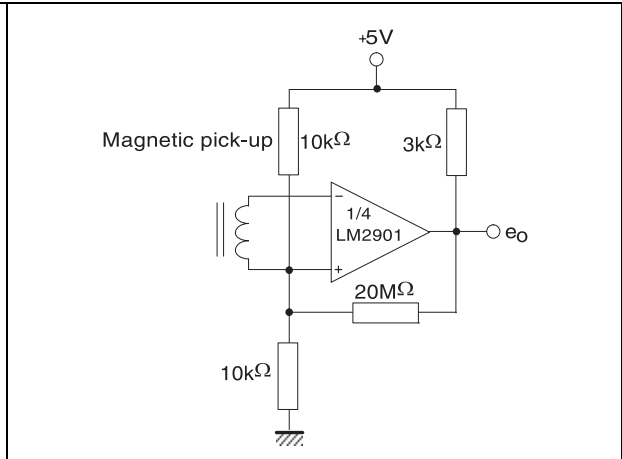

Figure 13. Low frequency op- amp with offset adjust

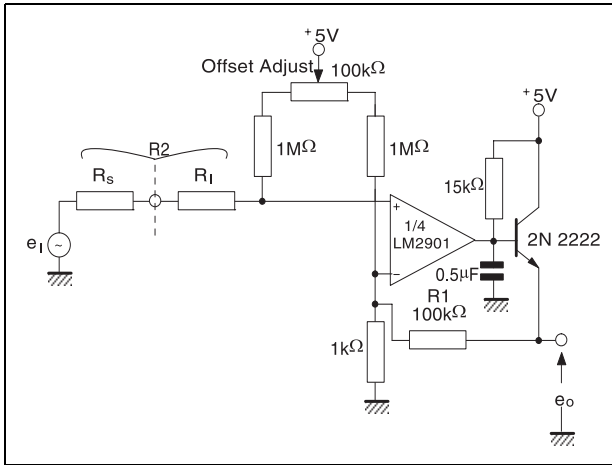

Figure 14. Zero crossing detector (single power supply)

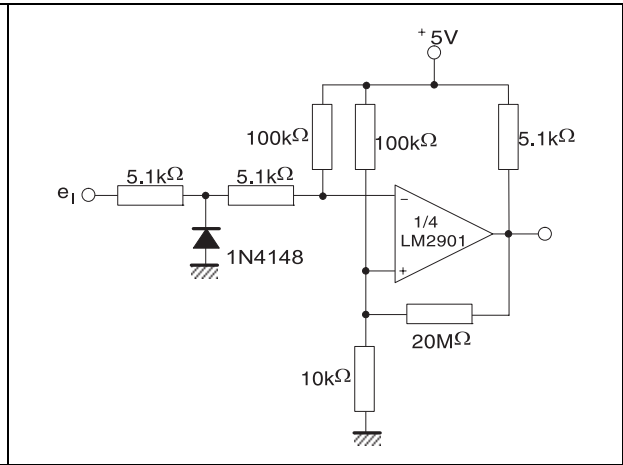

Figure 15. Limit comparator

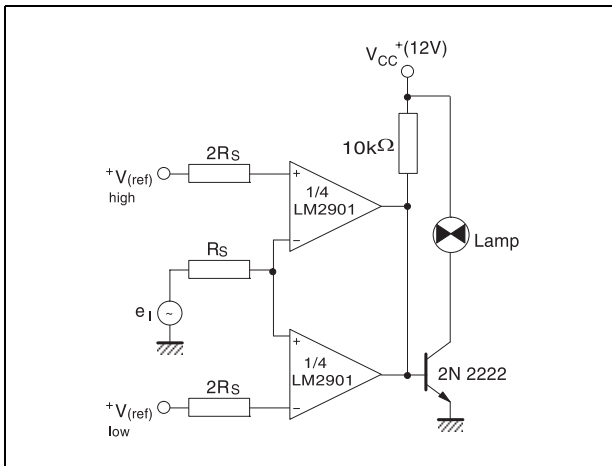

Figure 16. Split-supply applications - zero crossing detector

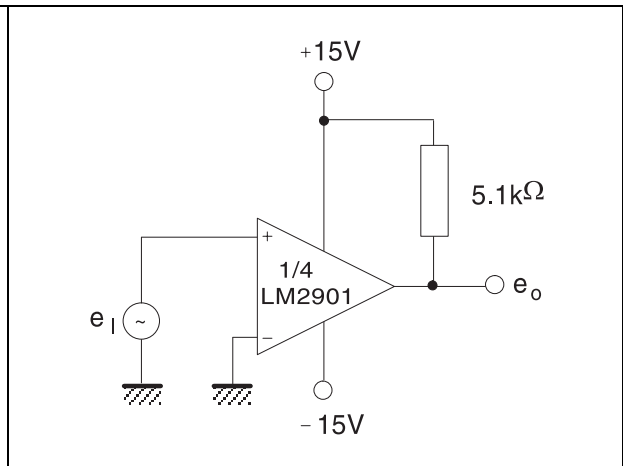

Figure 17. Crystal controlled oscillator

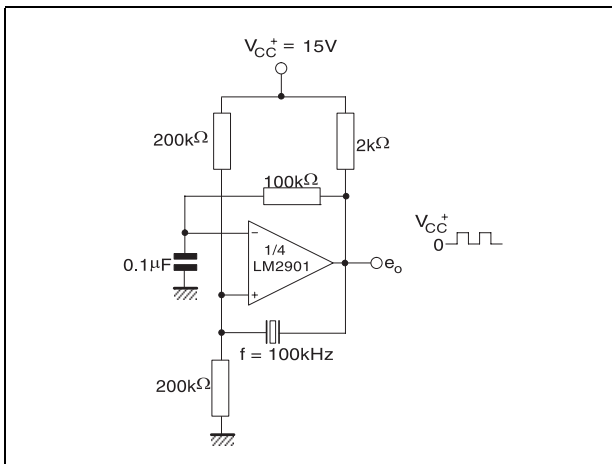

Figure 18. Comparator with a negative reference

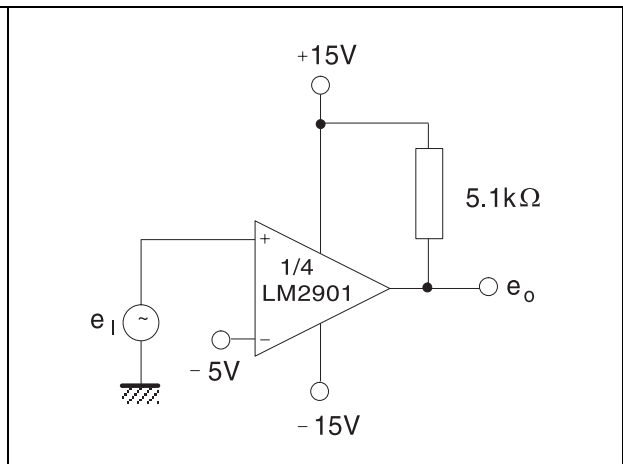

Figure 19. Time delay generator

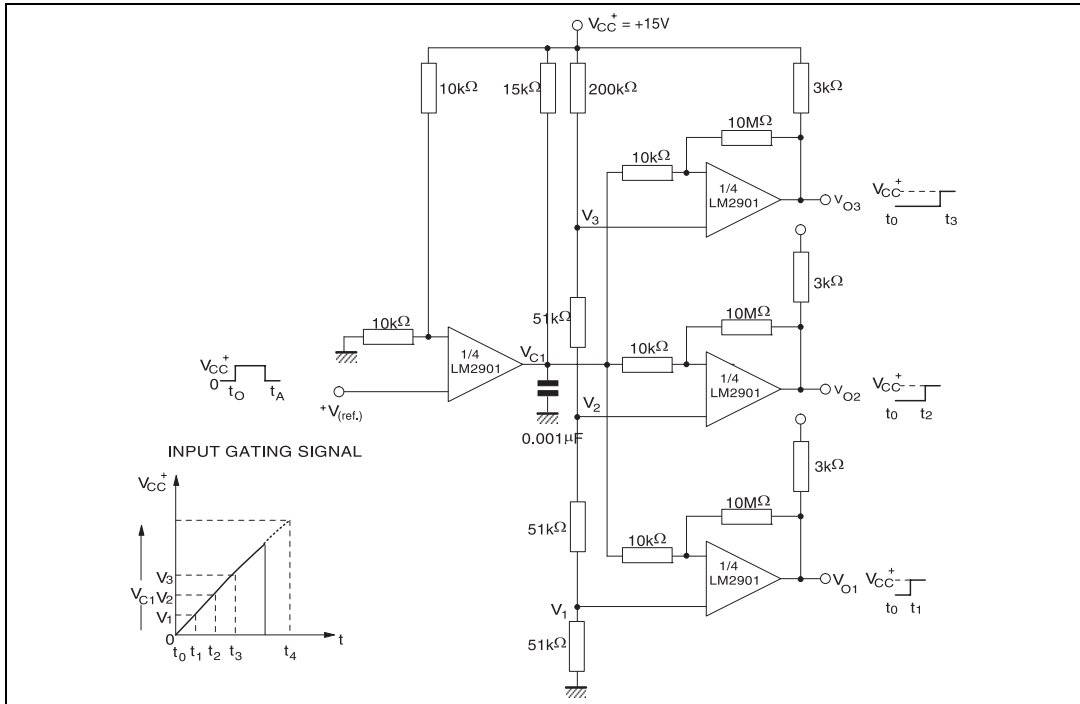
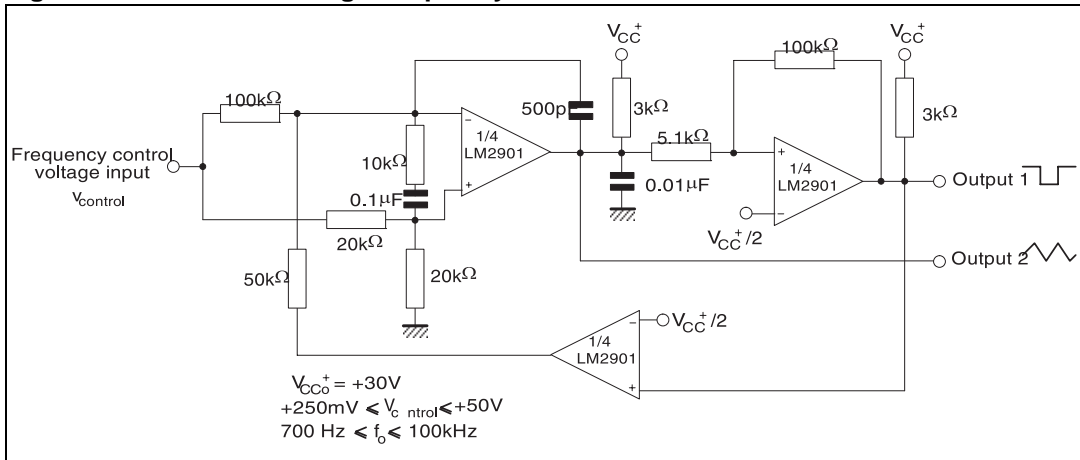

Figure 20. Two-decade high-frequency VCO



5 Package information

In order to meet environmental requirements, STMicroelectronics offers these devices in ECOPACK® packages. These packages have a lead-free second level interconnect. The category of second level interconnect is marked on the package and on the inner box label, in compliance with JEDEC Standard JESD97. The maximum ratings related to soldering conditions are also marked on the inner box label. ECOPACK is an STMicroelectronics trademark. ECOPACK specifications are available at: www.st.com.

5.1 DIP14 package information

Figure 21. DIP14 package mechanical drawing

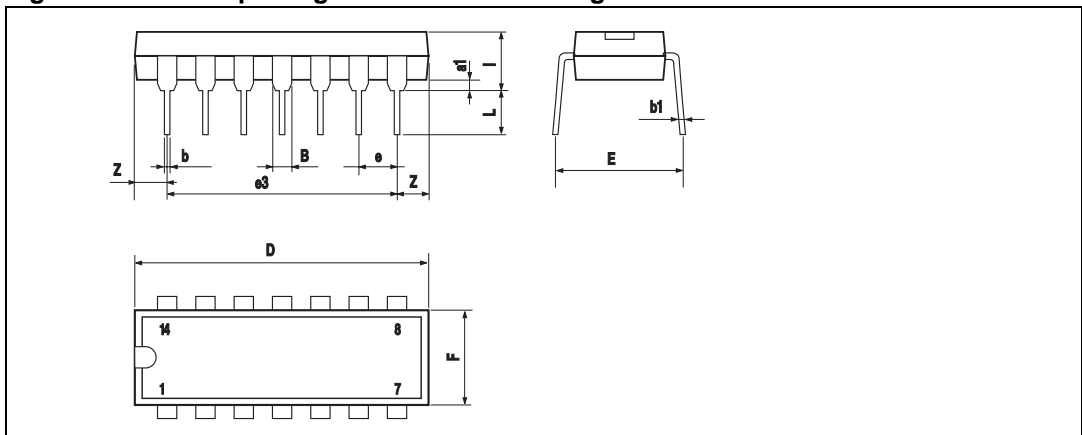

Table 4. DIP14 package mechanical data

Ref.	Dimensions					
	Millimeters			Inches		
	Min.	Typ.	Max.	Min.	Typ.	Max.
a1	0.51			0.020		
B	1.39		1.65	0.055		0.065
b		0.5			0.020	
b1		0.25			0.010	
D			20			0.787
E		8.5			0.335	
e		2.54			0.100	
e3		15.24			0.600	
F			7.1			0.280
l			5.1			0.201
L		3.3			0.130	
Z	1.27		2.54	0.050		0.100

5.2 SO-14 package information

Figure 22. SO-14 package mechanical drawing

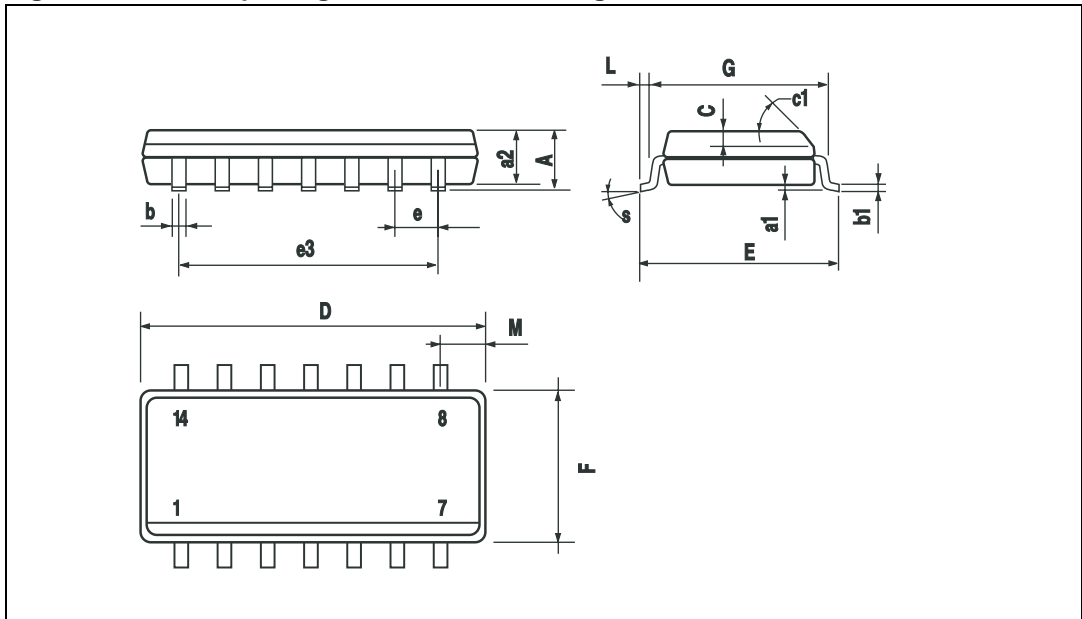

Table 5. SO-14 package mechanical data

Ref.	Dimensions					
	Millimeters			Inches		
	Min.	Typ.	Max.	Min.	Typ.	Max.
A			1.75			0.068
a1	0.1		0.2	0.003		0.007
a2			1.65			0.064
b	0.35		0.46	0.013		0.018
b1	0.19		0.25	0.007		0.010
C		0.5			0.019	
c1	45° (typ.)					
D	8.55		8.75	0.336		0.344
E	5.8		6.2	0.228		0.244
e		1.27			0.050	
e3		7.62			0.300	
F	3.8		4.0	0.149		0.157
G	4.6		5.3	0.181		0.208
L	0.5		1.27	0.019		0.050
M			0.68			0.026
S	8° (max.)					

5.3 TSSOP14 package information

Figure 23. TSSOP14 package mechanical drawing

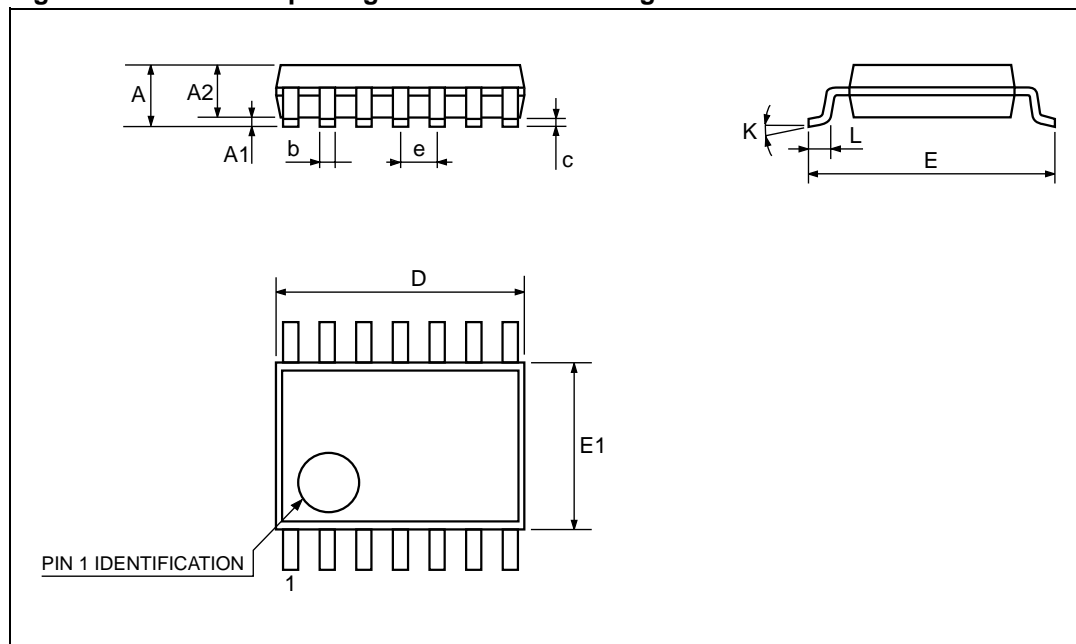

Table 6. TSSOP14 package mechanical data

Ref.	Dimensions					
	Millimeters			Inches		
	Min.	Typ.	Max.	Min.	Typ.	Max.
A			1.2			0.047
A1	0.05		0.15	0.002	0.004	0.006
A2	0.8	1	1.05	0.031	0.039	0.041
b	0.19		0.30	0.007		0.012
c	0.09		0.20	0.004		0.0089
D	4.9	5	5.1	0.193	0.197	0.201
E	6.2	6.4	6.6	0.244	0.252	0.260
E1	4.3	4.4	4.48	0.169	0.173	0.176
e		0.65 BSC			0.0256 BSC	
K	0°		8°	0°		8°
L1	0.45	0.60	0.75	0.018	0.024	0.030

6 Ordering information

Table 7. Order codes

Order code	Temperature range	Package	Packing	Marking
LM2901N	-40°C to +125°C	DIP14	Tube	LM2901N
LM2901D LM2901DT		SO-14	Tube or tape & reel	2901
LM2901PT		TSSOP14	Tape & reel	
LM2901YD ⁽¹⁾ LM2901YDT ⁽¹⁾		SO-14 (Automotive grade)	Tube or tape & reel	2901Y
LM2901YPT ⁽²⁾		TSSOP14 (Automotive grade)	Tape & reel	

1. Qualified and characterized according to AEC Q100 and Q003 or equivalent, advanced screening according to AEC Q001 & Q 002 or equivalent.
2. Qualification and characterization according to AEC Q100 and Q003 or equivalent, advanced screening according to AEC Q001 & Q 002 or equivalent are on-going.

7 Revision history

Table 8. Document revision history

Date	Revision	Changes
Jan-2002	1	Initial release.
Jul-2005	2	1 - PPAP references inserted in the datasheet see Table : Order codes on page 1 . 2 - ESD protection inserted in Table 1 on page 3 .
Oct-2005	3	The following changes were made in this revision: – PPAP part number added in table Order codes on page 1 . – Formatting changes throughout.
18-Jul-2006	4	ESD HBM value corrected in Table 1 on page 3 .
19-Dec-2007	5	Added R_{thja} and R_{thjc} parameters to Table 1: Absolute maximum ratings . Added footnotes for ESD parameters. Removed V_{icm} parameter from electrical characteristics in Table 3 . Reformatted package information in Section 5 . Added footnotes for automotive grade parts in Table 7: Order codes .

Please Read Carefully:

Information in this document is provided solely in connection with ST products. STMicroelectronics NV and its subsidiaries ("ST") reserve the right to make changes, corrections, modifications or improvements, to this document, and the products and services described herein at any time, without notice.

All ST products are sold pursuant to ST's terms and conditions of sale.

Purchasers are solely responsible for the choice, selection and use of the ST products and services described herein, and ST assumes no liability whatsoever relating to the choice, selection or use of the ST products and services described herein.

No license, express or implied, by estoppel or otherwise, to any intellectual property rights is granted under this document. If any part of this document refers to any third party products or services it shall not be deemed a license grant by ST for the use of such third party products or services, or any intellectual property contained therein or considered as a warranty covering the use in any manner whatsoever of such third party products or services or any intellectual property contained therein.

UNLESS OTHERWISE SET FORTH IN ST'S TERMS AND CONDITIONS OF SALE ST DISCLAIMS ANY EXPRESS OR IMPLIED WARRANTY WITH RESPECT TO THE USE AND/OR SALE OF ST PRODUCTS INCLUDING WITHOUT LIMITATION IMPLIED WARRANTIES OF MERCHANTABILITY, FITNESS FOR A PARTICULAR PURPOSE (AND THEIR EQUIVALENTS UNDER THE LAWS OF ANY JURISDICTION), OR INFRINGEMENT OF ANY PATENT, COPYRIGHT OR OTHER INTELLECTUAL PROPERTY RIGHT.

UNLESS EXPRESSLY APPROVED IN WRITING BY AN AUTHORIZED ST REPRESENTATIVE, ST PRODUCTS ARE NOT RECOMMENDED, AUTHORIZED OR WARRANTED FOR USE IN MILITARY, AIR CRAFT, SPACE, LIFE SAVING, OR LIFE SUSTAINING APPLICATIONS, NOR IN PRODUCTS OR SYSTEMS WHERE FAILURE OR MALFUNCTION MAY RESULT IN PERSONAL INJURY, DEATH, OR SEVERE PROPERTY OR ENVIRONMENTAL DAMAGE. ST PRODUCTS WHICH ARE NOT SPECIFIED AS "AUTOMOTIVE GRADE" MAY ONLY BE USED IN AUTOMOTIVE APPLICATIONS AT USER'S OWN RISK.

Resale of ST products with provisions different from the statements and/or technical features set forth in this document shall immediately void any warranty granted by ST for the ST product or service described herein and shall not create or extend in any manner whatsoever, any liability of ST.

ST and the ST logo are trademarks or registered trademarks of ST in various countries.

Information in this document supersedes and replaces all information previously supplied.

The ST logo is a registered trademark of STMicroelectronics. All other names are the property of their respective owners.

© 2007 STMicroelectronics - All rights reserved

STMicroelectronics group of companies

Australia - Belgium - Brazil - Canada - China - Czech Republic - Finland - France - Germany - Hong Kong - India - Israel - Italy - Japan - Malaysia - Malta - Morocco - Singapore - Spain - Sweden - Switzerland - United Kingdom - United States of America

www.st.com