

## LM2623-Q1 Automotive Gated-Oscillator-Based DC-DC Boost Converter

### 1 Features

- AEC-Q100 Qualified for Automotive Applications:
  - Device Temperature Grade 1:  $-40^{\circ}\text{C}$  to  $125^{\circ}\text{C}$  Ambient Operating Temperature
  - Device HBM ESD Classification Level 2
  - Device CDM ESD Classification Level C4A
- Good Efficiency Over a Very Wide Load Range
- Very Low Output Voltage Ripple
- Up to 2-MHz Switching Frequency
- 0.9-V to 14-V Operating Voltage
- 1.1-V Start-Up Voltage
- 1.24-V to 14-V Adjustable Output Voltage
- $0.17\text{-}\Omega$  Internal MOSFET
- Up to 90% Regulator Efficiency
- $80\text{-}\mu\text{A}$  Typical Operating Current (Into  $V_{\text{DD}}$  Pin of Supply)
- Low Shutdown Current ( $I_{\text{Q}} < 2.5\ \mu\text{A}$ )
- 4-mm x 4-mm Thermally Enhanced WSON Package Option

### 2 Applications

- Automotive Camera
- Automotive Radar
- Automotive GPS
- Flash Memory Programming
- White-LED Drive

### 3 Description

The LM2623-Q1 is a high-efficiency, general-purpose, step-up DC-DC switching regulator for automotive systems. The device accepts an input voltage between 0.9 V and 14 V and converts it into a regulated output voltage between 1.24 V and 14 V.

In order to adapt to a number of applications, the LM2623-Q1 allows the designer to program the output voltage, the operating frequency (300 kHz to 2 MHz), and duty cycle (17% to 90%) to optimize performance. The selected values can be fixed or can vary with input voltage or input-to-output voltage ratio. The LM2623-Q1 uses a very simple, on/off regulation mode to produce good efficiency and stable operation over a wide operating range. The device normally regulates by skipping switching cycles when it reaches the regulation limit (pulse frequency modulation (PFM)).

Refer to [Non-Linear Effect](#) and [Choosing the Correct C3 Capacitor](#) to resolve any design challenges before board design is finalized.

#### Device Information<sup>(1)</sup>

PART NUMBER	PACKAGE	BODY SIZE (NOM)
LM2623-Q1	WSON (14)	4.00 mm x 4.00 mm

(1) For all available packages, see the orderable addendum at the end of the data sheet.

#### Typical Application

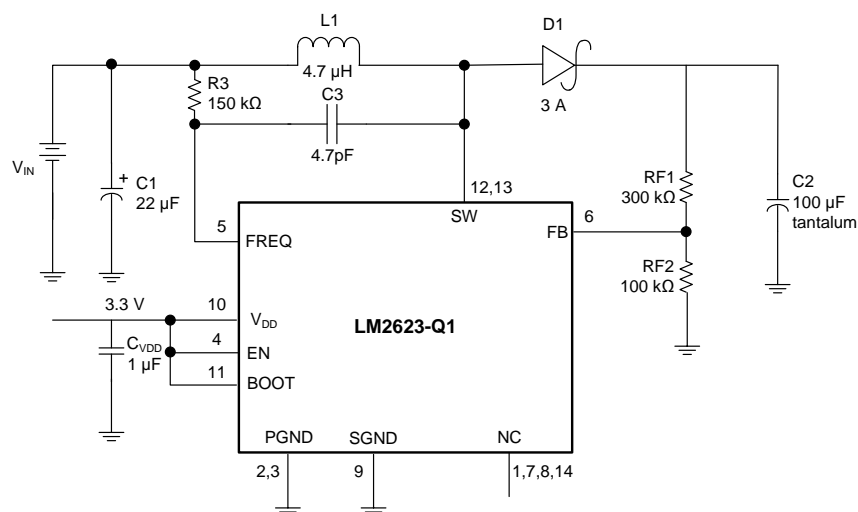

Copyright © 2017, Texas Instruments Incorporated



## Table of Contents

<b>1 Features</b> .....	<b>1</b>	<b>8 Applications and Implementation</b> .....	<b>11</b>
<b>2 Applications</b> .....	<b>1</b>	8.1 Application Information.....	11
<b>3 Description</b> .....	<b>1</b>	8.2 Typical Application .....	11
<b>4 Revision History</b> .....	<b>2</b>	<b>9 Power Supply Recommendations</b> .....	<b>13</b>
<b>5 Pin Configuration and Functions</b> .....	<b>3</b>	<b>10 Layout</b> .....	<b>14</b>
<b>6 Specifications</b> .....	<b>4</b>	10.1 Layout Guidelines .....	14
6.1 Absolute Maximum Ratings .....	4	10.2 Layout Example .....	15
6.2 ESD Ratings.....	4	10.3 WSON Package Devices .....	15
6.3 Recommended Operating Conditions.....	4	<b>11 Device And Documentation Support</b> .....	<b>16</b>
6.4 Thermal Information .....	4	11.1 Device Support.....	16
6.5 Electrical Characteristics.....	5	11.2 Documentation Support .....	16
6.6 Typical Characteristics.....	6	11.3 Receiving Notification of Documentation Updates	16
<b>7 Detailed Description</b> .....	<b>8</b>	11.4 Community Resources.....	16
7.1 Overview .....	8	11.5 Trademarks .....	16
7.2 Functional Block Diagram .....	8	11.6 Electrostatic Discharge Caution.....	16
7.3 Feature Description.....	9	11.7 Glossary .....	16
7.4 Device Functional Modes.....	10	<b>12 Mechanical, Packaging, And Orderable Information</b> .....	<b>16</b>

## 4 Revision History

NOTE: Page numbers for previous revisions may differ from page numbers in the current version.

DATE	REVISION	NOTES
October 2017	*	Initial release

## 5 Pin Configuration and Functions

**NHL Package  
14-Pin WSON  
Top View**

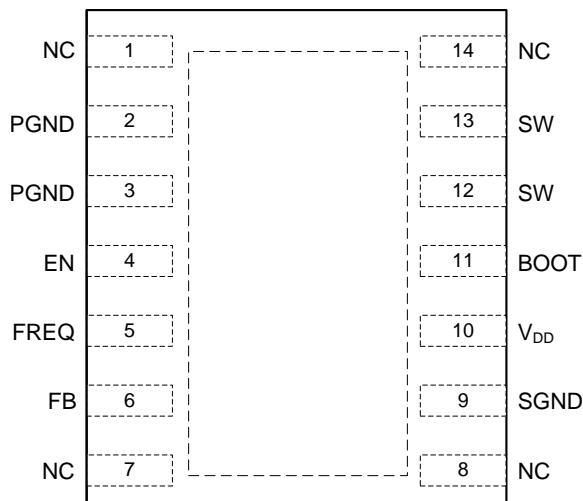

**Pin Functions**

PIN		TYPE	DESCRIPTION
NO.	NAME		
1	NC	—	No connect
2, 3	PGND	GND	Power ground (pins 2 and 3 <i>must</i> be shorted together)
4	EN	Digital	Active-low shutdown input
5	FREQ	Analog	Frequency adjust; connect an external resistor between this pin and a voltage source sets the switching frequency of the LM2623-Q1.
6	FB	Analog	Output voltage feedback
7	NC	—	No connect
8	NC	—	No connect
9	SGND	GND	Signal ground
10	V <sub>DD</sub>	Power	Power supply for internal circuitry
11	BOOT	Analog	Bootstrap supply for the gate drive of internal MOSFET power switch
12, 13	SW	Analog	Drain of the internal MOSFET power switch (pins 12 and 13 <i>must</i> be shorted together)
14	NC	—	No connect
DAP	DAP	Thermal	Solder to board for enhanced thermal dissipation; must be electrically isolated/floating.

## 6 Specifications

### 6.1 Absolute Maximum Ratings

 over operating free-air temperature range (unless otherwise noted)<sup>(1) (2)</sup>

		MIN	MAX	UNIT
Input pins	SW pin voltage	-0.5	14.5	V
	BOOT, VDD, EN, and FB pins	-0.5	10	V
	FREQ pin		100	μA
Power dissipation ( $T_A = 25^\circ\text{C}$ ) <sup>(3)</sup>			500	mW
$T_{J\_MAX}$ <sup>(3)</sup>			150	°C
Storage temperature, $T_{stg}$		-55	150	°C

- (1) Stresses beyond those listed under Absolute Maximum Ratings may cause permanent damage to the device. These are stress ratings only, which do not imply functional operation of the device at these or any other conditions beyond those indicated under Recommended Operating Conditions. Exposure to absolute-maximum-rated conditions for extended periods may affect device reliability.
- (2) If Military/Aerospace specified devices are required, contact the Texas Instruments Sales Office / Distributors for availability and specifications.
- (3) The maximum power dissipation must be derated at elevated temperatures and is dictated by  $T_{J\_MAX}$  (maximum junction temperature),  $R_{\theta JA}$  (junction to ambient thermal resistance), and  $T_A$  (ambient temperature). The maximum allowable power dissipation at any temperature is  $P_{D\_MAX} = (T_{J\_MAX} - T_A)/R_{\theta JA}$  or the number given in the Absolute Maximum Rating, whichever is lower.

### 6.2 ESD Ratings

			VALUE	UNIT
$V_{(ESD)}$ Electrostatic discharge	Human body model (HBM), per AEC Q100-002 <sup>(1)</sup>	All pins except 12 and 13	±2000	V
		Pins 12 and 13	±1000	
	Charged device model (CDM), per AEC Q100-011		±500	

- (1) AEC Q100-002 indicates that HBM stressing shall be in accordance with the ANSI/ESDA/JEDEC JS-001 specification.

### 6.3 Recommended Operating Conditions

over operating free-air temperature range (unless otherwise noted)

		MIN	NOM	MAX	UNIT
Input pins	$V_{DD}$ pin	3		5	V
	FB and EN pins	0		$V_{DD}$	V
	BOOT pin	0		10	V
Operating junction temperature range, $T_J$		-40		125	°C

### 6.4 Thermal Information

THERMAL METRIC <sup>(1)</sup>		LM2623-Q1	UNIT
		NHL (WSON)	
		14 PINS	
$R_{\theta JA}$	Junction-to-ambient thermal resistance	37.6	°C/W
$R_{\theta JC(top)}$	Junction-to-case (top) thermal resistance	26.9	°C/W
$R_{\theta JB}$	Junction-to-board thermal resistance	15.0	°C/W
$\psi_{JT}$	Junction-to-top characterization parameter	0.3	°C/W
$\psi_{JB}$	Junction-to-board characterization parameter	4.7	°C/W

- (1) For more information about traditional and new thermal metrics, see the [Semiconductor and IC Package Thermal Metrics](#) application report.

## 6.5 Electrical Characteristics

Limits apply for  $T_J = 25^\circ\text{C}$  and  $V_{DD} = V_{OUT} = 3.3\text{ V}$ , unless otherwise specified.

PARAMETER	TEST CONDITIONS	MIN	TYP	MAX	UNIT	
<b>GENERAL</b>						
$V_{DD\_ST}$	Start-up supply voltage $25^\circ\text{C}$	$I_{LOAD} = 0\text{ mA}^{(1)}$		1.1	V	
$V_{IN\_OP}$	Minimum operating supply voltage (once started)	$I_{LOAD} = 0\text{ mA}$		0.65	V	
$V_{FB}$	FB pin voltage			1.24	V	
		$-40^\circ\text{C}$ to $85^\circ\text{C}$		1.2028		1.2772
		$-40^\circ\text{C}$ to $125^\circ\text{C}$		1.2028		1.2772
$V_{OUT\_MAX}$	Maximum output voltage			14	V	
$\eta$	Efficiency	$V_{IN} = 3.6\text{ V}; V_{OUT} = 5\text{ V}, I_{LOAD} = 500\text{ mA}$		87%		
		$V_{IN} = 2.5\text{ V}; V_{OUT} = 3.3\text{ V}, I_{LOAD} = 200\text{ mA}$		87%		
D	Switch duty cycle			17%		
$I_{DD}$	Operating quiescent current <sup>(2)</sup>	FB pin > 1.3 V, EN pin at $V_{DD}$		80	$\mu\text{A}$	
		FB pin > 1.3 V, EN pin at $V_{DD}$ , $-40^\circ\text{C}$ to $85^\circ\text{C}$		110		
		FB pin > 1.3 V, EN pin at $V_{DD}$ , $-40^\circ\text{C}$ to $125^\circ\text{C}$		110		
$I_{SD}$	Shutdown quiescent current <sup>(3)</sup>	$V_{DD}$ , BOOT, and SW pins at 5 V, EN pin < 200 mV		0.01	$\mu\text{A}$	
		$V_{DD}$ , BOOT, and SW pins at 5 V, EN pin < 200 mV, $-40^\circ\text{C}$ to $85^\circ\text{C}$		2.5		
		$V_{DD}$ , BOOT, and SW pins at 5 V, EN pin < 200 mV, $-40^\circ\text{C}$ to $125^\circ\text{C}$		2.5		
$I_{CL}$	Switch peak current limit	2.2	2.85		A	
$R_{DSON}$	MOSFET switch on resistance			0.17	$\Omega$	
		$-40^\circ\text{C}$ to $85^\circ\text{C}$		0.26		
		$-40^\circ\text{C}$ to $125^\circ$		0.26		
<b>ENABLE SECTION</b>						
$V_{EN\_LO}$	EN pin voltage low <sup>(4)</sup>	$-40^\circ\text{C}$ to $85^\circ\text{C}$		$0.15 V_{DD}$	V	
		$-40^\circ\text{C}$ to $125^\circ\text{C}$		$0.15 V_{DD}$		
$V_{EN\_HI}$	EN pin voltage high <sup>(4)</sup>	$-40^\circ\text{C}$ to $85^\circ\text{C}$		$0.7 V_{DD}$	V	
		$-40^\circ\text{C}$ to $125^\circ\text{C}$		$0.7 V_{DD}$		

(1)  $V_{DD}$  tied to BOOT and EN pins. Frequency pin tied to  $V_{DD}$  through 121-K $\Omega$  resistor.  $V_{DD\_ST} = V_{DD}$  when start-up occurs.  $V_{IN}$  is  $V_{DD} + D1$  voltage (usually 10 mV to 50 mV at start-up).

(2) This is the current into the  $V_{DD}$  pin.

(3) This is the total current into pins  $V_{DD}$ , BOOT, SW, and FREQ.

(4) When the EN pin is below  $V_{EN\_LO}$ , the regulator is shut down; when it is above  $V_{EN\_HI}$ , the regulator is operating.

## 6.6 Typical Characteristics

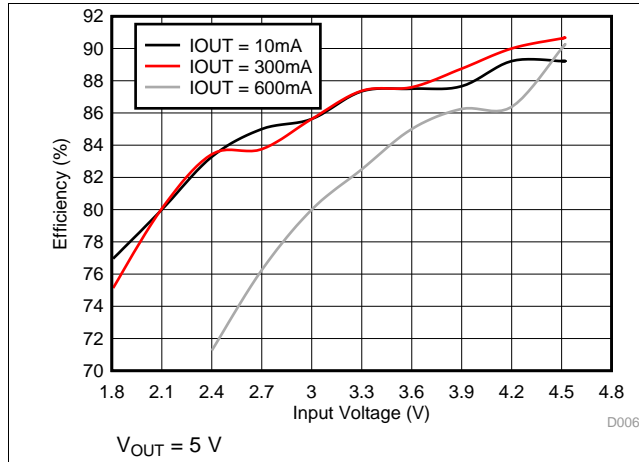

Figure 1. Efficiency vs Supply Voltage

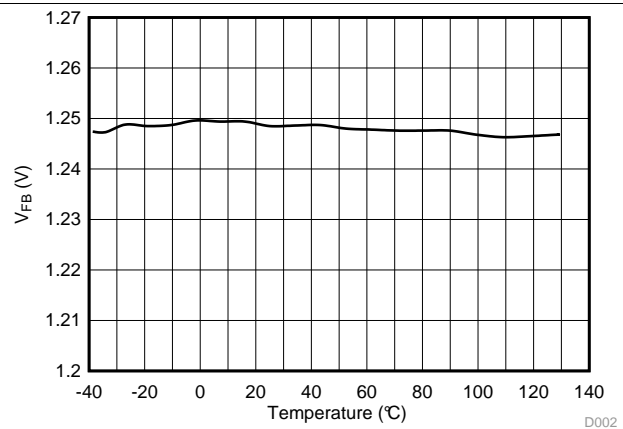

Figure 2.  $V_{FB}$  vs Temperature

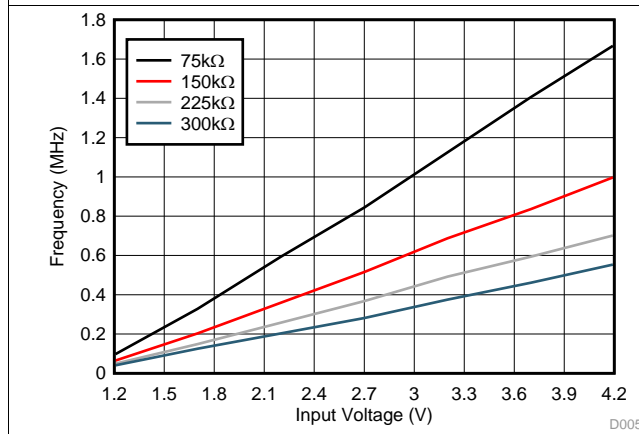

Figure 3. Frequency vs  $V_{IN}$

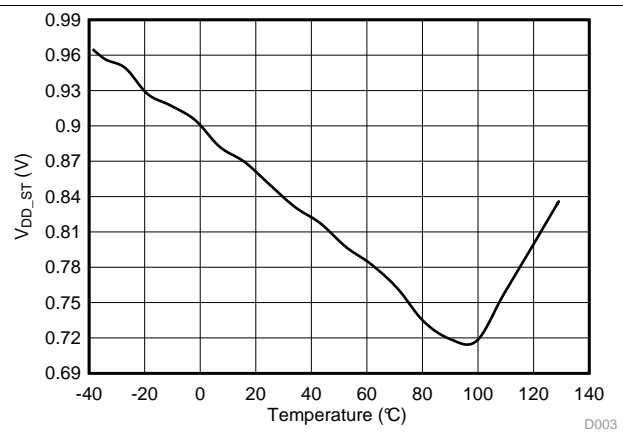

Figure 4. Maximum Start-Up Voltage vs Temperature

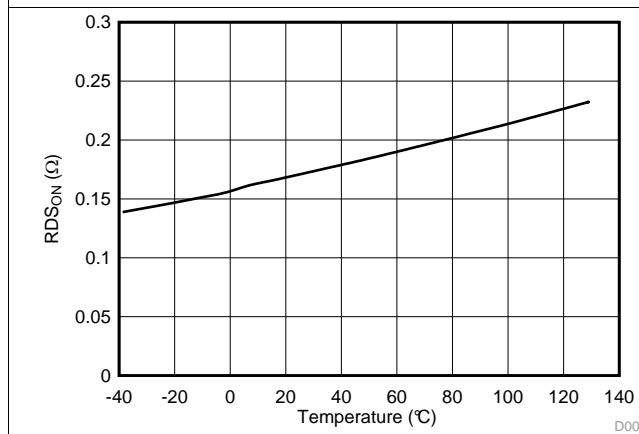

Figure 5. Typical  $R_{DS(ON)}$  vs Temperature

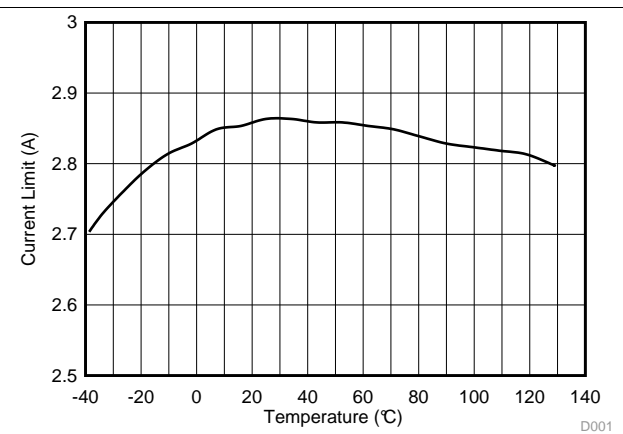

Figure 6. Typical Current Limit vs Temperature

Typical Characteristics (continued)

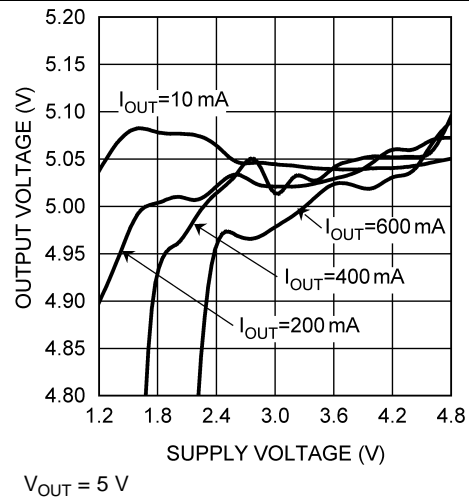

Figure 7. Output Voltage vs Supply Voltage

## 7 Detailed Description

### 7.1 Overview

The LM2623-Q1 device is designed to provide step-up DC-DC voltage regulation in battery-powered and low-input voltage systems. The device combines a step-up switching regulator, N-channel power MOSFET, built-in current limit, thermal limit, and voltage reference in a single 14-pin WSON package (see [Functional Block Diagram](#)). The switching DC-DC regulator boosts an input voltage between 0.9 V and 14 V to a regulated output voltage between 1.24 V and 14 V. The LM2623-Q1 starts from a low 1.1-V input and remains operational down to below 0.9 V. A high-efficiency gated-oscillator topology offers an output of up to 2 A at low step-up ratios.

### 7.2 Functional Block Diagram

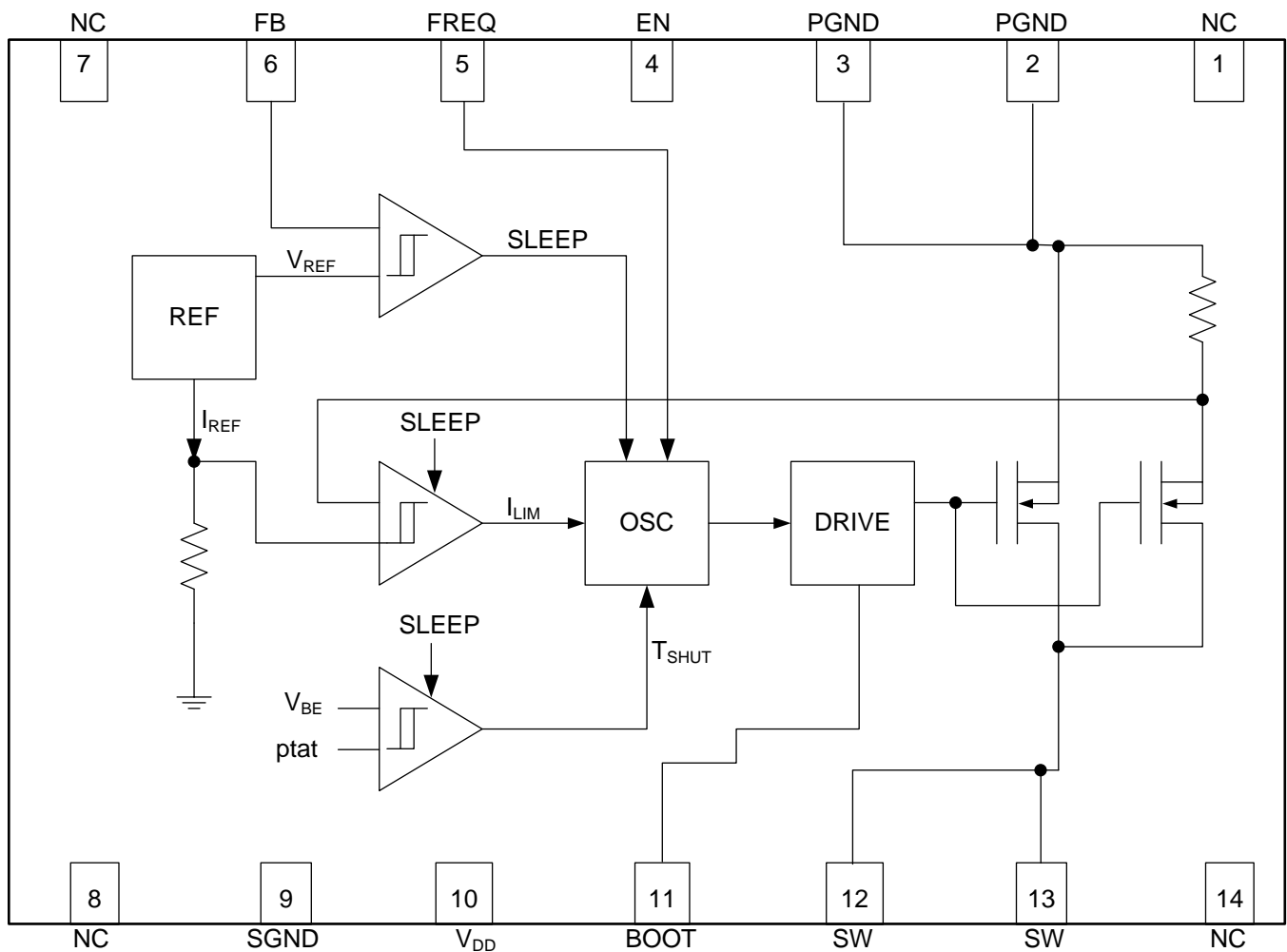

Copyright © 2017, Texas Instruments Incorporated



## 7.3 Feature Description

### 7.3.1 Gated Oscillator Control Scheme

The on/off regulation mode of the LM2623-Q1, along with its ultra-low quiescent current, results in good efficiency over a very wide load range. The internal oscillator frequency can be programmed using an external resistor to be constant or vary with the battery voltage. Adding a capacitor to program the frequency allows the designer to adjust the duty cycle and optimize it for the application. Adding a resistor in addition to the capacitor allows the duty cycle to dynamically compensate for changes to the input/output voltage ratio. This is called a *ratio-adaptive gated-oscillator circuit*. See the [Typical Application](#) for a sample application circuit. Using the correct RC components to adjust the oscillator allows the device to run with low ripple and high efficiency over a wide range of loads and input/output voltages.

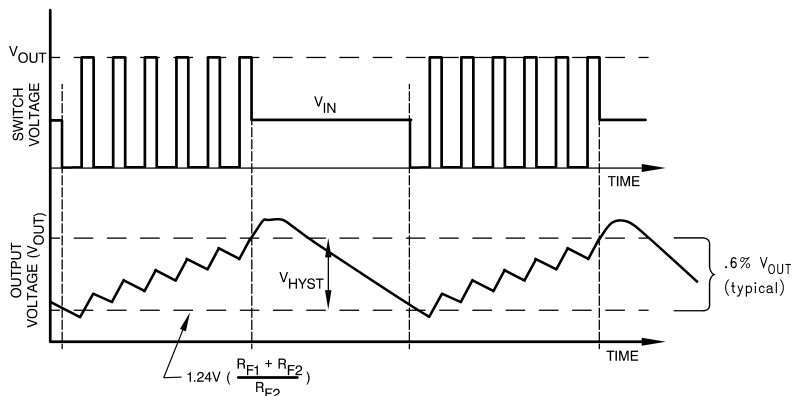

Figure 8. Typical Step-Up Regulator Waveforms

### 7.3.2 Cycle-To-Cycle PFM

When the load does not vary over a wide range, ratio adaptive circuit techniques can be used to achieve cycle to cycle PFM regulation and lower ripple (or smaller output capacitors). The key to success is matching the duty cycle of the circuit closely to what is required by the input-to-output voltage ratio. This ratio then must be dynamically adjusted for input voltage changes (usually caused by batteries running down). The chosen ratio must allow most of the energy in each switching cycle to be delivered to the load and only a small amount to be stored. When the regulation limit is reached, the overshoot is small, and the system settles at an equilibrium point where it adjusts the off time in each switching cycle to meet the current requirements of the load. The off-time adjustment is done by exceeding the regulation limit during each switching cycle and waiting until the voltage drops below the limit again to start the next switching cycle. The current in the coil never goes to zero like it frequently does in the hysteretic operating mode of circuits with wide load variations or duty cycles that are not matched to the input/output voltage ratio. Optimizing the duty cycle for a given set of input/output voltages conditions can be done by referencing the circuit values in [AN-1221 LM2623 General Purpose, Boost Converter Circuit](#).

### 7.3.3 Shutdown

The LM2623-Q1 features a shutdown mode that reduces the quiescent current to less than an ensured 2.5  $\mu\text{A}$  over temperature. This extends the life of the battery in battery-powered applications. During shutdown, all feedback and control circuitry is turned off. The output voltage of the regulator drops to one diode drop below the input voltage. Entry into the shutdown mode is controlled by the active-low logic input pin EN (pin 4). When the logic input to this pin is pulled below 0.15  $V_{DD}$ , the device goes into shutdown mode. The logic input to this pin must be above 0.7  $V_{DD}$  for the device to work in normal step-up mode. If EN is pulled above 0.7  $V_{DD}$  the SW pin switches continuously for experimentally tested 5  $\mu\text{s}$  period, regardless of the output voltage. Once this time period is expired the feedback and gated oscillator scheme take over to regulate the output voltage.

## Feature Description (continued)

### 7.3.4 Internal Current Limit and Thermal Protection

An internal cycle-by-cycle current limit serves as a protection feature. This is set high enough (2.85 A typical, approximately 4 A maximum) so it does not come into effect during normal operating conditions. An internal thermal protection circuit disables the MOSFET power switch when the junction temperature ( $T_J$ ) exceeds about 160°C. The switch is re-enabled when  $T_J$  drops below approximately 135°C.

## 7.4 Device Functional Modes

### 7.4.1 Pulse Frequency Modulation (PFM)

Pulse frequency modulation is typically accomplished by switching continuously until the voltage limit is reached and skipping cycles after that to just maintain it. This results in a somewhat hysteretic mode of operation. The coil stores more energy each cycle as the current ramps up to high levels. When the voltage limit is reached, the system usually overshoots to a higher voltage than required, due to the stored energy in the coil (see [Figure 8](#)). The system also undershoots somewhat when it starts switching again because it has depleted all the stored energy in the coil and must store more energy to reach equilibrium with the load. Larger output capacitors and smaller inductors reduce the ripple in these situations. The frequency being filtered, however, is not the basic switching frequency. It is a lower frequency determined by the load, the input/output voltage and the circuit parameters. This mode of operation is useful in situations where the load variation is significant. Power-managed computer systems, for instance, may vary from zero to full load while the system is on, and this is usually the preferred regulation mode for such systems.

### 7.4.2 Low Voltage Start-Up

The LM2623-Q1 can start up from voltages as low as 1.1 V. On start-up, the control circuitry switches the N-channel MOSFET continuously until the output reaches 3 V. After this output voltage is reached, the normal step-up regulator feedback and gated oscillator control scheme take over. Once the device is in regulation, it can operate down to 0.9 V input, because the internal power for the device can be boot-strapped from the output using the  $V_{DD}$  pin.

## 8 Applications and Implementation

### NOTE

Information in the following applications sections is not part of the TI component specification, and TI does not warrant its accuracy or completeness. TI's customers are responsible for determining suitability of components for their purposes. Customers should validate and test their design implementation to confirm system functionality.

### 8.1 Application Information

The LM2623-Q1 is suitable for automotive applications, and supports shutdown mode for low quiescent current when EN input is low. Output voltage level can be adjusted by changing feedback resistor divider values from 1.24-V to 14-V range. The maximum switching frequency is 2MHz.

### 8.2 Typical Application

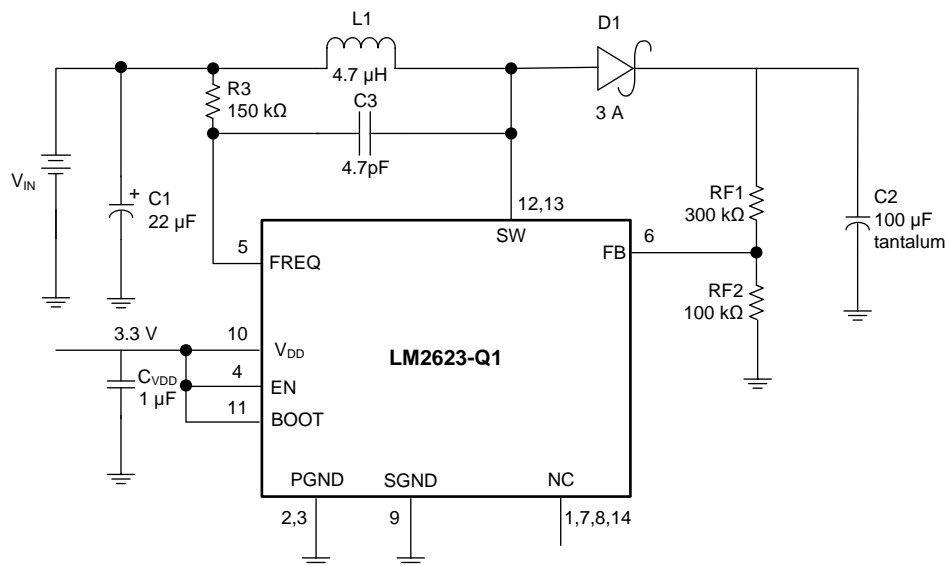

Copyright © 2017, Texas Instruments Incorporated

Figure 9. LM2623-Q1 Typical Application

#### 8.2.1 Design Requirements

The LM2623-Q1 allows the designer to vary output voltage, operating frequency and duty cycle to optimize device performance (see [Detailed Design Procedure](#) for details).

For typical boost-converter applications, use the parameters listed in [Table 1](#).

Table 1. Design Parameters

DESIGN PARAMETER	EXAMPLE VALUE
Input voltage	0.9 V to 14 V
Output voltage	1.24 V to 14 V (adjustable)
Output current	2 A (maximum)

## 8.2.2 Detailed Design Procedure

### 8.2.2.1 Non-Linear Effect

The LM2623-Q1 takes advantage of a non-linear effect, allowing for the duty cycle to be programmable. C3 in [Figure 9](#) allows for the duty cycle to be programmable.

### 8.2.2.2 Choosing the Correct C3 Capacitor

The duty cycle of the internal oscillator is programmable with the C3 capacitor. Choosing the correct C3 capacitor to obtain the appropriate duty cycle for a particular application circuit is a trial-and-error process. The non-linear effect that C3 produces is dependent on the input voltage and output voltage values. The correct C3 capacitor for specific input and output voltage values cannot be calculated. Choosing the correct C3 capacitance is best done by trial and error, in conjunction with the checking of the inductor peak current to make sure it is not too close to the current limit of the device. As the C3 capacitor value increases, so does the duty cycle; conversely, as the C3 capacitor value decreases, the duty cycle decreases. An incorrect choice of the C3 capacitor can result in the device prematurely tripping the current limit and/or double pulsing, which could lead to the output voltage not being stable. Optimizing the duty cycle for a given set of input/output voltages conditions can be done by referencing the component values in [AN-1221 LM2623 General Purpose, Boost Converter Circuit](#).

### 8.2.2.3 Setting the Output Voltage

The output voltage of the step-up regulator can be set by connecting a feedback resistive divider made of R<sub>F1</sub> and R<sub>F2</sub>. The resistor values are selected as follows:

$$R_{F1} = R_{F2} \times [(V_{OUT} / 1.24) - 1] \quad (1)$$

A value of 50 kΩ to 100 kΩ is suggested for R<sub>F2</sub>. R<sub>F1</sub> can be selected using [Equation 1](#).

### 8.2.2.4 V<sub>DD</sub> Supply

The V<sub>DD</sub> supply must be between 3 V to 5 V for the LM2623-Q1 device. This voltage can be bootstrapped from a much lower input voltage by simply connecting the V<sub>DD</sub> pin to V<sub>OUT</sub>. In the event that the V<sub>DD</sub> supply voltage is not a low-ripple voltage source (less than 200 mV), it may be advisable to use an RC filter to clean it up. Excessive ripple on V<sub>DD</sub> may reduce the efficiency.

### 8.2.2.5 Setting the Switching Frequency

The switching frequency of the oscillator is selected by choosing an external resistor (R3) connected between V<sub>IN</sub> and the FREQ pin. See [Figure 3](#) in the [Typical Characteristics](#) for choosing the R3 value to achieve the desired switching frequency. A high switching frequency allows the use of very small surface mount inductors and capacitors and results in a very small solution size. TI recommends a switching frequency between 300 kHz and 2 MHz.

### 8.2.2.6 Output Diode Selection

Use a Schottky diode for the output diode. The forward current rating of the diode must be higher than the peak input current, and the reverse voltage rating must be higher than the output voltage. Do not use ordinary rectifier diodes, because slow switching speeds and long recovery times cause the efficiency and the load regulation to suffer.

### 8.2.3 Application Curves

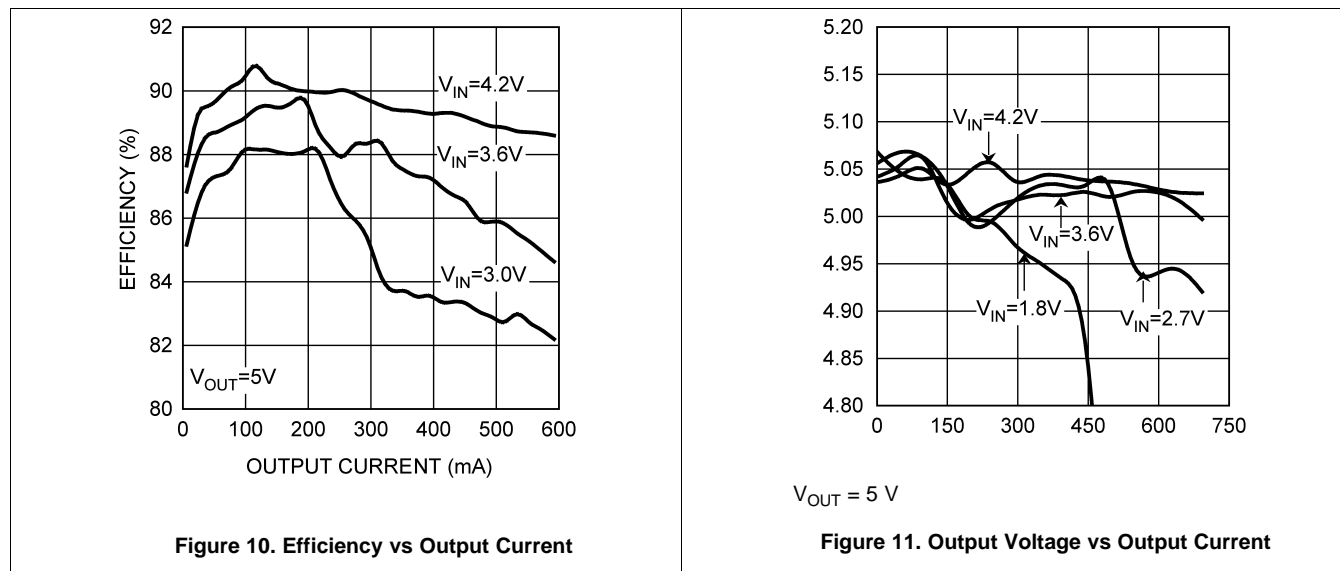

## 9 Power Supply Recommendations

The LM2623-Q1 can start up from voltages as low as 1.1 V. On start-up, the control circuitry switches the N-channel MOSFET continuously until the output reaches 3 V. After this output voltage is reached, the normal step-up regulator feedback and gated oscillator control scheme take over. Once the device is in regulation, it can operate down to below 0.9 V input, because the internal power for the device can be boot-strapped from the output using the  $V_{DD}$  pin.

## 10 Layout

### 10.1 Layout Guidelines

[Figure 12](#) follows proper layout guidelines — use as a guide for laying out the LM2623-Q1 circuit. The LM2623-Q1 inductive boost converter sees a high switched voltage at the SW pin and a step current through the Schottky diode and output capacitor each switching cycle. The high switching voltage can create interference into nearby nodes due to electric field coupling ( $I = C \times dV/dt$ ). The large step current through the diode and the output capacitor can cause a large voltage spike at the SW and BOOST pins due to parasitic inductance in the step current conducting path ( $V = L \times di/dt$ ). Board layout guidelines are geared towards minimizing this electric field coupling and conducted noise.

[Boost Output Capacitor Placement](#), [Schottky Diode Placement](#), and [Boost Input /  \$V\_{DD}\$  Capacitor Placement](#) detail the main (layout sensitive) areas of the LM2623-Q1 inductive boost converter in order of decreasing importance:

#### 10.1.1 Boost Output Capacitor Placement

Because the output capacitor is in the path of the inductor current discharge path, it experiences a high-current step from 0 A to the peak inductor current each time the switch turns off, and the Schottky diode turns on. Any inductance along this series path from the diodes cathode, through  $C_{OUT}$ , and back into the LM2623-Q1 GND pin contributes to voltage spikes at SW. These spikes can potentially overvoltage the SW and BOOST pins, or feed through to GND. To avoid this,  $C_{OUT+}$  must be connected as close as possible to the cathode of the Schottky diode, and  $C_{OUT-}$  must be connected as close as possible to the LM2623-Q1 GND bumps. The best placement for  $C_{OUT}$  is on the same layer as the LM2623-Q1 to avoid any vias that can add excessive series inductance.

#### 10.1.2 Schottky Diode Placement

In the LM2623-Q1 device boost circuit the Schottky diode is in the path of the inductor current discharge. As a result the Schottky diode detects a high-current step from 0 A to the peak inductor current each time the switch turns off, and the diode turns on. Any inductance in series with the diode causes a voltage spike at SW. This can potentially overvoltage the SW pin, or feed through to VOUT and through the output capacitor, into GND. Connecting the anode of the diode as close as possible to the SW pin, and connecting the cathode of the diode as close as possible to  $C_{OUT}$  reduces the parasitic inductance and minimizes these voltage spikes.

#### 10.1.3 Boost Input / $V_{DD}$ Capacitor Placement

The LM2623-Q1 input capacitor filters the inductor current ripple and the internal MOSFET driver currents. The inductor current ripple can add input voltage ripple due to any series resistance in the input power path. The MOSFET driver currents can add voltage spikes on the input due to the inductance in series with the  $V_{IN}/V_{DD}$  and the input capacitor. Place the input capacitor close to the inductor and minimize the current-loop area. Close placement of the  $V_{DD}$  capacitor to the  $V_{DD}$  and GND pins is critical because any series inductance can create voltage spikes that could appear on the  $V_{IN}/V_{DD}$  supply line.

## 10.2 Layout Example

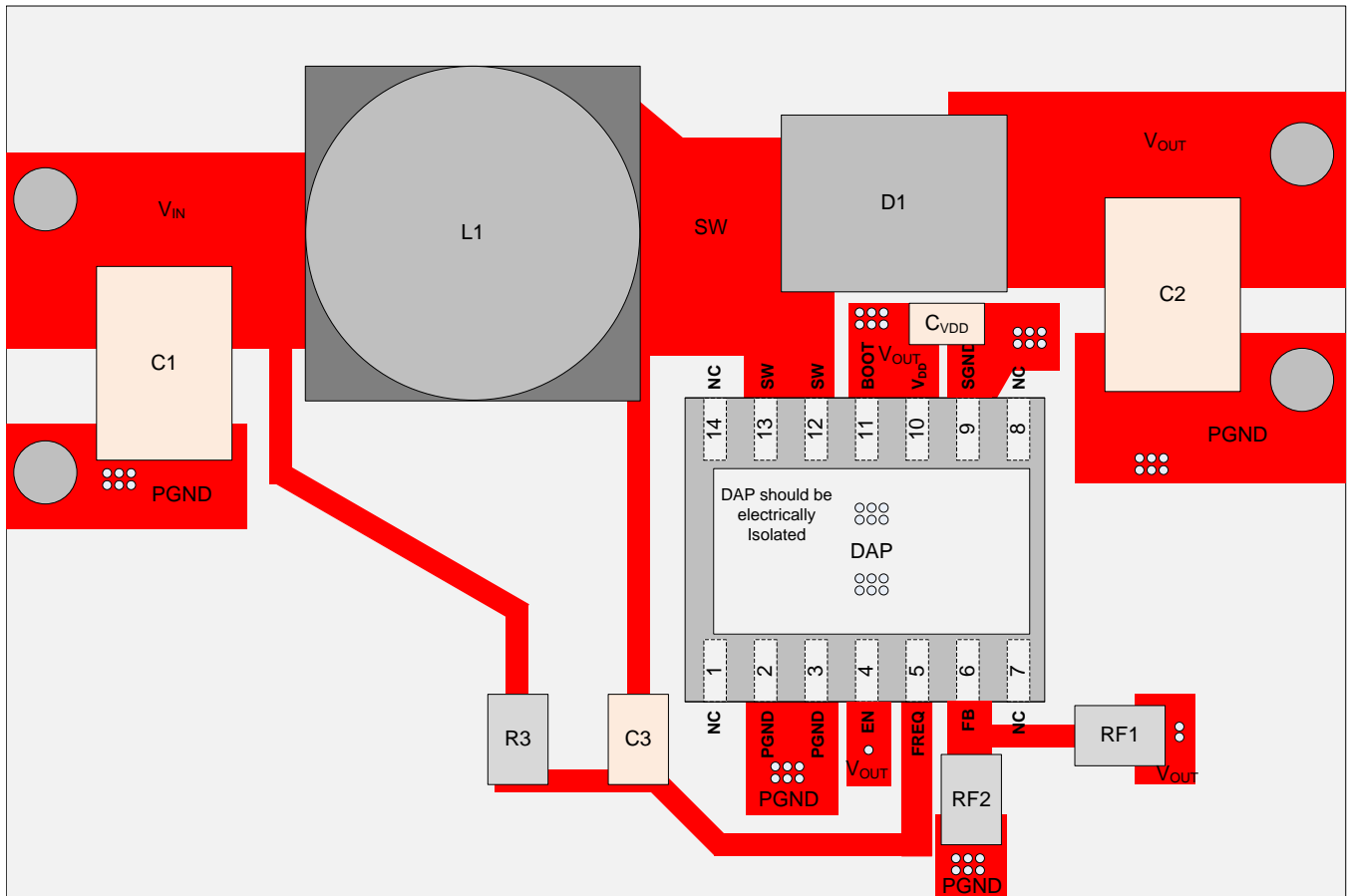

Figure 12. LM2623-Q1 Layout Example

## 10.3 WSON Package Devices

The LM2623-Q1 is offered in the 14-pin WSON surface mount package — for details of the thermal performance as well as mounting and soldering specifications, refer to [Leadless Leadframe Package \(LLP\)](#).

## 11 Device And Documentation Support

### 11.1 Device Support

#### 11.1.1 Third-Party Products Disclaimer

TI'S PUBLICATION OF INFORMATION REGARDING THIRD-PARTY PRODUCTS OR SERVICES DOES NOT CONSTITUTE AN ENDORSEMENT REGARDING THE SUITABILITY OF SUCH PRODUCTS OR SERVICES OR A WARRANTY, REPRESENTATION OR ENDORSEMENT OF SUCH PRODUCTS OR SERVICES, EITHER ALONE OR IN COMBINATION WITH ANY TI PRODUCT OR SERVICE.

### 11.2 Documentation Support

#### 11.2.1 Related Documentation

For related documentation, see the following:

- [AN-1187 Leadless Leadframe Package \(LLP\)](#)
- [AN-1221 LM2623 General Purpose, Boost Converter Circuit](#)
- [AN-1258 LM2623 Boost Converter - A Simple Supply](#)

#### 11.3 Receiving Notification of Documentation Updates

To receive notification of documentation updates, navigate to the device product folder on ti.com. In the upper right corner, click on *Alert me* to register and receive a weekly digest of any product information that has changed. For change details, review the revision history included in any revised document.

### 11.4 Community Resources

The following links connect to TI community resources. Linked contents are provided "AS IS" by the respective contributors. They do not constitute TI specifications and do not necessarily reflect TI's views; see TI's [Terms of Use](#).

**TI E2E™ Online Community** *TI's Engineer-to-Engineer (E2E) Community*. Created to foster collaboration among engineers. At e2e.ti.com, you can ask questions, share knowledge, explore ideas and help solve problems with fellow engineers.

**Design Support** *TI's Design Support* Quickly find helpful E2E forums along with design support tools and contact information for technical support.

### 11.5 Trademarks

E2E is a trademark of Texas Instruments.  
All other trademarks are the property of their respective owners.

### 11.6 Electrostatic Discharge Caution



These devices have limited built-in ESD protection. The leads should be shorted together or the device placed in conductive foam during storage or handling to prevent electrostatic damage to the MOS gates.

### 11.7 Glossary

**SLYZ022** — *TI Glossary*.

This glossary lists and explains terms, acronyms, and definitions.

## 12 Mechanical, Packaging, And Orderable Information

The following pages include mechanical, packaging, and orderable information. This information is the most current data available for the designated devices. This data is subject to change without notice and revision of this document. For browser-based versions of this data sheet, refer to the left-hand navigation.



**PACKAGING INFORMATION**

Orderable Device	Status (1)	Package Type	Package Drawing	Pins	Package Qty	Eco Plan (2)	Lead/Ball Finish (6)	MSL Peak Temp (3)	Op Temp (°C)	Device Marking (4/5)	Samples
LM2623QNHLRQ1	ACTIVE	WSON	NHL	14	4500	Green (RoHS & no Sb/Br)	CU SN	Level-2-260C-1 YEAR	-40 to 125	2623Q1	<a href="#">Samples</a>
LM2623QNHLTQ1	ACTIVE	WSON	NHL	14	250	Green (RoHS & no Sb/Br)	CU SN	Level-2-260C-1 YEAR	-40 to 125	2623Q1	<a href="#">Samples</a>

(1) The marketing status values are defined as follows:

**ACTIVE:** Product device recommended for new designs.

**LIFEBUY:** TI has announced that the device will be discontinued, and a lifetime-buy period is in effect.

**NRND:** Not recommended for new designs. Device is in production to support existing customers, but TI does not recommend using this part in a new design.

**PREVIEW:** Device has been announced but is not in production. Samples may or may not be available.

**OBsolete:** TI has discontinued the production of the device.

(2) **RoHS:** TI defines "RoHS" to mean semiconductor products that are compliant with the current EU RoHS requirements for all 10 RoHS substances, including the requirement that RoHS substance do not exceed 0.1% by weight in homogeneous materials. Where designed to be soldered at high temperatures, "RoHS" products are suitable for use in specified lead-free processes. TI may reference these types of products as "Pb-Free".

**RoHS Exempt:** TI defines "RoHS Exempt" to mean products that contain lead but are compliant with EU RoHS pursuant to a specific EU RoHS exemption.

**Green:** TI defines "Green" to mean the content of Chlorine (Cl) and Bromine (Br) based flame retardants meet JS709B low halogen requirements of <=1000ppm threshold. Antimony trioxide based flame retardants must also meet the <=1000ppm threshold requirement.

(3) MSL, Peak Temp. - The Moisture Sensitivity Level rating according to the JEDEC industry standard classifications, and peak solder temperature.

(4) There may be additional marking, which relates to the logo, the lot trace code information, or the environmental category on the device.

(5) Multiple Device Markings will be inside parentheses. Only one Device Marking contained in parentheses and separated by a "~" will appear on a device. If a line is indented then it is a continuation of the previous line and the two combined represent the entire Device Marking for that device.

(6) Lead/Ball Finish - Orderable Devices may have multiple material finish options. Finish options are separated by a vertical ruled line. Lead/Ball Finish values may wrap to two lines if the finish value exceeds the maximum column width.

**Important Information and Disclaimer:**The information provided on this page represents TI's knowledge and belief as of the date that it is provided. TI bases its knowledge and belief on information provided by third parties, and makes no representation or warranty as to the accuracy of such information. Efforts are underway to better integrate information from third parties. TI has taken and continues to take reasonable steps to provide representative and accurate information but may not have conducted destructive testing or chemical analysis on incoming materials and chemicals. TI and TI suppliers consider certain information to be proprietary, and thus CAS numbers and other limited information may not be available for release.

In no event shall TI's liability arising out of such information exceed the total purchase price of the TI part(s) at issue in this document sold by TI to Customer on an annual basis.

**OTHER QUALIFIED VERSIONS OF LM2623-Q1 :**

- Catalog: [LM2623](#)

## NOTE: Qualified Version Definitions:

- Catalog - TI's standard catalog product

NHL0014B

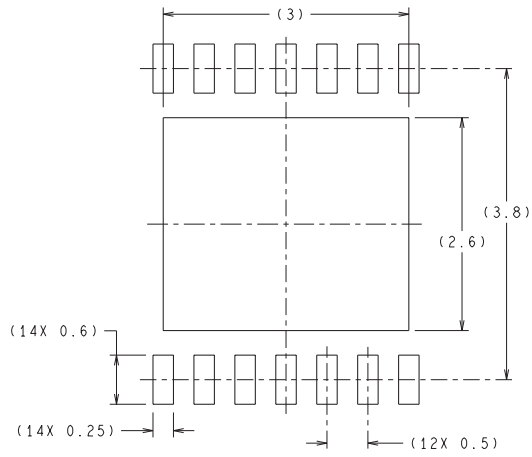

RECOMMENDED LAND PATTERN

DIMENSIONS ARE IN MILLIMETERS  
DIMENSIONS IN ( ) FOR REFERENCE ONLY

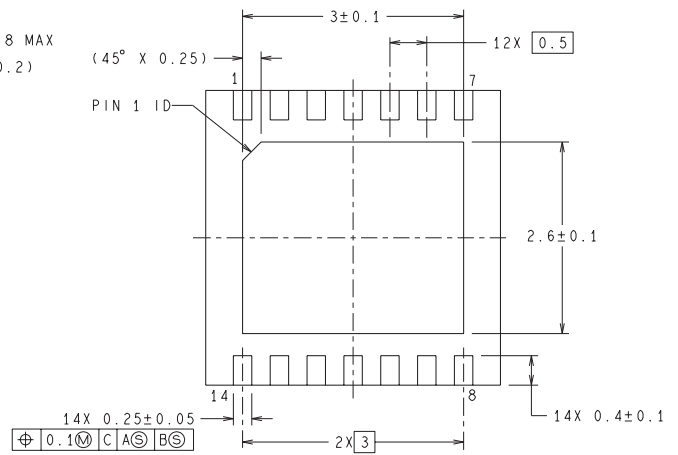
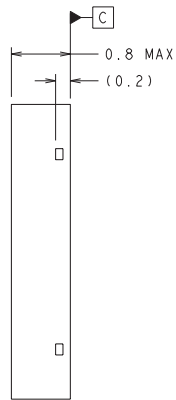
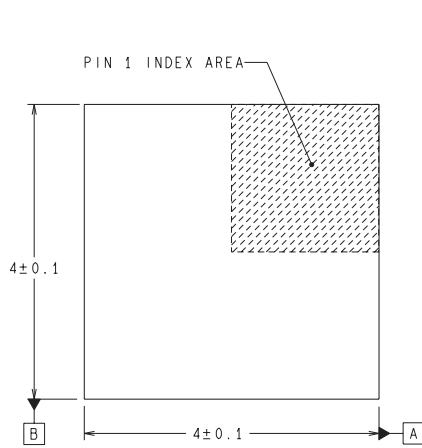

SDA14B (Rev A)

## IMPORTANT NOTICE

Texas Instruments Incorporated (TI) reserves the right to make corrections, enhancements, improvements and other changes to its semiconductor products and services per JESD46, latest issue, and to discontinue any product or service per JESD48, latest issue. Buyers should obtain the latest relevant information before placing orders and should verify that such information is current and complete.

TI's published terms of sale for semiconductor products (<http://www.ti.com/sc/docs/stdterms.htm>) apply to the sale of packaged integrated circuit products that TI has qualified and released to market. Additional terms may apply to the use or sale of other types of TI products and services.

Reproduction of significant portions of TI information in TI data sheets is permissible only if reproduction is without alteration and is accompanied by all associated warranties, conditions, limitations, and notices. TI is not responsible or liable for such reproduced documentation. Information of third parties may be subject to additional restrictions. Resale of TI products or services with statements different from or beyond the parameters stated by TI for that product or service voids all express and any implied warranties for the associated TI product or service and is an unfair and deceptive business practice. TI is not responsible or liable for any such statements.

Buyers and others who are developing systems that incorporate TI products (collectively, "Designers") understand and agree that Designers remain responsible for using their independent analysis, evaluation and judgment in designing their applications and that Designers have full and exclusive responsibility to assure the safety of Designers' applications and compliance of their applications (and of all TI products used in or for Designers' applications) with all applicable regulations, laws and other applicable requirements. Designer represents that, with respect to their applications, Designer has all the necessary expertise to create and implement safeguards that (1) anticipate dangerous consequences of failures, (2) monitor failures and their consequences, and (3) lessen the likelihood of failures that might cause harm and take appropriate actions. Designer agrees that prior to using or distributing any applications that include TI products, Designer will thoroughly test such applications and the functionality of such TI products as used in such applications.

TI's provision of technical, application or other design advice, quality characterization, reliability data or other services or information, including, but not limited to, reference designs and materials relating to evaluation modules, (collectively, "TI Resources") are intended to assist designers who are developing applications that incorporate TI products; by downloading, accessing or using TI Resources in any way, Designer (individually or, if Designer is acting on behalf of a company, Designer's company) agrees to use any particular TI Resource solely for this purpose and subject to the terms of this Notice.

TI's provision of TI Resources does not expand or otherwise alter TI's applicable published warranties or warranty disclaimers for TI products, and no additional obligations or liabilities arise from TI providing such TI Resources. TI reserves the right to make corrections, enhancements, improvements and other changes to its TI Resources. TI has not conducted any testing other than that specifically described in the published documentation for a particular TI Resource.

Designer is authorized to use, copy and modify any individual TI Resource only in connection with the development of applications that include the TI product(s) identified in such TI Resource. NO OTHER LICENSE, EXPRESS OR IMPLIED, BY ESTOPPEL OR OTHERWISE TO ANY OTHER TI INTELLECTUAL PROPERTY RIGHT, AND NO LICENSE TO ANY TECHNOLOGY OR INTELLECTUAL PROPERTY RIGHT OF TI OR ANY THIRD PARTY IS GRANTED HEREIN, including but not limited to any patent right, copyright, mask work right, or other intellectual property right relating to any combination, machine, or process in which TI products or services are used. Information regarding or referencing third-party products or services does not constitute a license to use such products or services, or a warranty or endorsement thereof. Use of TI Resources may require a license from a third party under the patents or other intellectual property of the third party, or a license from TI under the patents or other intellectual property of TI.

TI RESOURCES ARE PROVIDED "AS IS" AND WITH ALL FAULTS. TI DISCLAIMS ALL OTHER WARRANTIES OR REPRESENTATIONS, EXPRESS OR IMPLIED, REGARDING RESOURCES OR USE THEREOF, INCLUDING BUT NOT LIMITED TO ACCURACY OR COMPLETENESS, TITLE, ANY EPIDEMIC FAILURE WARRANTY AND ANY IMPLIED WARRANTIES OF MERCHANTABILITY, FITNESS FOR A PARTICULAR PURPOSE, AND NON-INFRINGEMENT OF ANY THIRD PARTY INTELLECTUAL PROPERTY RIGHTS. TI SHALL NOT BE LIABLE FOR AND SHALL NOT DEFEND OR INDEMNIFY DESIGNER AGAINST ANY CLAIM, INCLUDING BUT NOT LIMITED TO ANY INFRINGEMENT CLAIM THAT RELATES TO OR IS BASED ON ANY COMBINATION OF PRODUCTS EVEN IF DESCRIBED IN TI RESOURCES OR OTHERWISE. IN NO EVENT SHALL TI BE LIABLE FOR ANY ACTUAL, DIRECT, SPECIAL, COLLATERAL, INDIRECT, PUNITIVE, INCIDENTAL, CONSEQUENTIAL OR EXEMPLARY DAMAGES IN CONNECTION WITH OR ARISING OUT OF TI RESOURCES OR USE THEREOF, AND REGARDLESS OF WHETHER TI HAS BEEN ADVISED OF THE POSSIBILITY OF SUCH DAMAGES.

Unless TI has explicitly designated an individual product as meeting the requirements of a particular industry standard (e.g., ISO/TS 16949 and ISO 26262), TI is not responsible for any failure to meet such industry standard requirements.

Where TI specifically promotes products as facilitating functional safety or as compliant with industry functional safety standards, such products are intended to help enable customers to design and create their own applications that meet applicable functional safety standards and requirements. Using products in an application does not by itself establish any safety features in the application. Designers must ensure compliance with safety-related requirements and standards applicable to their applications. Designer may not use any TI products in life-critical medical equipment unless authorized officers of the parties have executed a special contract specifically governing such use. Life-critical medical equipment is medical equipment where failure of such equipment would cause serious bodily injury or death (e.g., life support, pacemakers, defibrillators, heart pumps, neurostimulators, and implantables). Such equipment includes, without limitation, all medical devices identified by the U.S. Food and Drug Administration as Class III devices and equivalent classifications outside the U.S.

TI may expressly designate certain products as completing a particular qualification (e.g., Q100, Military Grade, or Enhanced Product). Designers agree that it has the necessary expertise to select the product with the appropriate qualification designation for their applications and that proper product selection is at Designers' own risk. Designers are solely responsible for compliance with all legal and regulatory requirements in connection with such selection.

Designer will fully indemnify TI and its representatives against any damages, costs, losses, and/or liabilities arising out of Designer's non-compliance with the terms and provisions of this Notice.