

DATA SHEET

AU211/LM111/211/311/311B Voltage comparator

Product data
Supersedes data of 2001 Aug 03

2003 Sep 30

Voltage comparator

AU211/LM111/211/311/311B

DESCRIPTION

The LM111 series are voltage comparators that have input currents approximately a hundred times lower than devices like the μ A710. They are designed to operate over a wider range of supply voltages; from standard ± 15 V op amp supplies down to a single 3 V supply. Their output is compatible with RTL, DTL, and TTL as well as MOS circuits. Further, they can drive lamps or relays, switching voltages up to 50 V at currents as high as 50mA.

Both the inputs and the outputs of the LM111 series can be isolated from system ground, and the output can drive loads referred to ground, the positive supply, or the negative supply. Offset balancing and strobe capability are provided and outputs can be wire-ORed.

Although slower than the μ A710 (200 ns response time versus 40 ns), the devices are also much less prone to spurious oscillations. The LM111 series has the same pin configuration as the μ A710 series.

FEATURES

- Operates from single 3 V supply (LM311B)
- Maximum input bias current: 150 nA (LM311: 250 nA)
- Maximum offset current: 20 nA (LM311: 50 nA)
- Differential input voltage range: ± 30 V
- Power consumption: 135 mW at ± 15 V
- High sensitivity: 200 V/mV
- Zero crossing detector

PIN CONFIGURATION

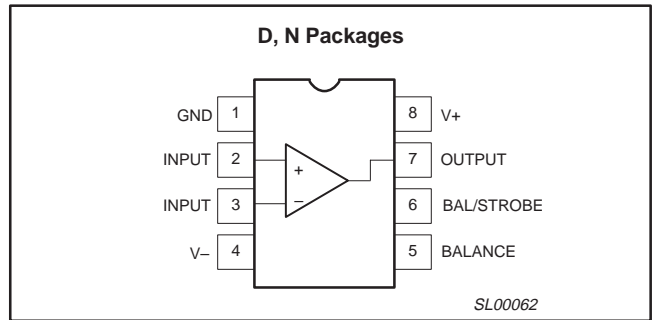

Figure 1. Pin Configuration

APPLICATIONS

- Precision squarer
- Positive/negative peak detector
- Low voltage adjustable reference supply
- Switching power amplifier

ORDERING INFORMATION

DESCRIPTION	TEMPERATURE RANGE	ORDER CODE	DWG #
8-Pin Plastic Small Outline Package (SO)	-40 °C to +125 °C	AU211D	SOT96-1
8-Pin Plastic Small Outline Package (SO)	-55 °C to +125 °C	LM111D	SOT96-1
8-Pin Plastic Dual In-Line Package (DIP)	-55 °C to +125 °C	LM111N	SOT97-1
8-Pin Plastic Small Outline Package (SO)	-25 °C to +85 °C	LM211D	SOT96-1
8-Pin Plastic Dual In-Line Package (DIP)	-25 °C to +85 °C	LM211N	SOT97-1
8-Pin Plastic Small Outline Package (SO)	0 °C to +70 °C	LM311D	SOT96-1
8-Pin Plastic Dual In-Line Package (DIP)	0 °C to +70 °C	LM311N	SOT97-1
8-Pin Plastic Small Outline Package (SO)	0 °C to +70 °C	LM311BD	SOT96-1
8-Pin Plastic Dual In-Line Package (DIP)	0 °C to +70 °C	LM311BN	SOT97-1

Voltage comparator

AU211/LM111/211/311/311B

EQUIVALENT SCHEMATIC

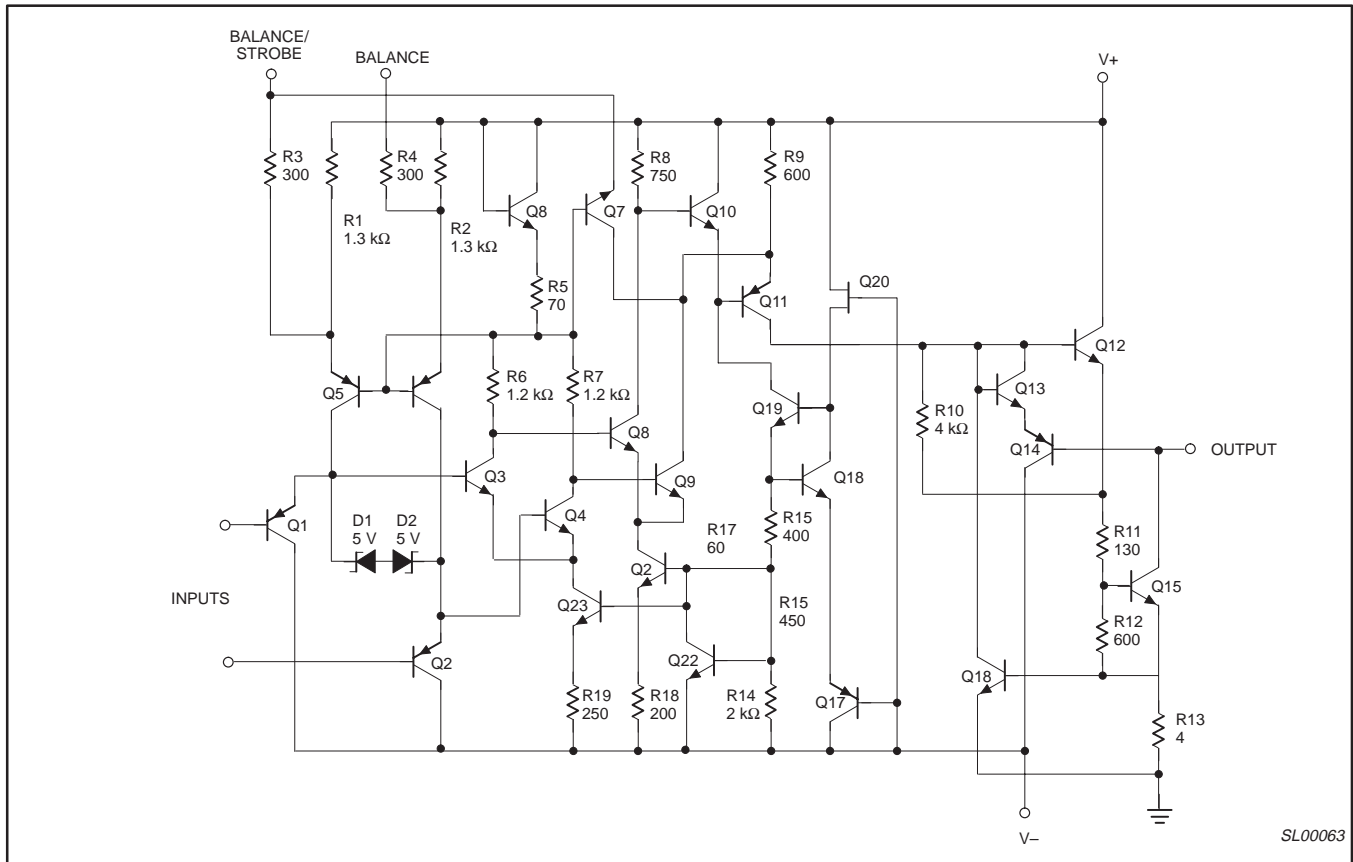

Figure 2. Equivalent Schematic

ABSOLUTE MAXIMUM RATINGS

SYMBOL	PARAMETER	RATING	UNIT	
V _S	Total supply voltage	36	V	
	Output to negative supply voltage	LM111/LM211 LM311/LM311B	50 40	V
	Ground to negative supply voltage	30	V	
	Differential input voltage	±30	V	
V _{IN}	Input voltage ¹	±15	V	
P _{D MAX}	Maximum power dissipation, T _{amb} = 25 °C (still-air) ²	N package D package	1190 780	mW
I	Output short-circuit duration	10	sec	
T _{amb}	Operating ambient temperature range	AU211 LM111 LM211 LM311/LM311B	-40 to +125 -55 to +125 -25 to +85 0 to +70	°C
T _{stg}	Storage temperature range	-65 to +150	°C	
T _{slid}	Lead soldering temperature (10 sec max)	230	°C	

NOTES:

- This rating applies for ±15 V supplies. The positive input voltage limit is 30 V above the negative supply. The negative input voltage limit is equal to the negative supply voltage or 30 V below the positive supply, whichever is less.
- Derate above 25 °C, at the following rates:
 N package at 9.5 mW/°C
 D package at 6.2 mW/°C

Voltage comparator

AU211/LM111/211/311/311B

DC ELECTRICAL CHARACTERISTICS^{1, 2, 3, 6}

Over temperature range unless otherwise specified.

SYMBOL	PARAMETER	TEST CONDITIONS	AU211 LM111/LM211			LM311			LM311B			UNIT
			Min	Typ	Max	Min	Typ	Max	Min	Typ	Max	
V _{OS}	Input offset voltage ³	T _{amb} = 25 °C; R _S ≤ 50 kΩ		0.7	3.0		2.0	7.5		2.0	7.5	mV
I _{OS}	Input offset current ³	T _{amb} = 25 °C		4.0	10		6.0	50		6	25	nA
I _{BIAS}	Input bias current	T _{amb} = 25 °C		60	100		100	250		100	200	nA
A _V	Voltage gain	T _{amb} = 25 °C		200			200			200		V/mV
	Response time ⁴	T _{amb} = 25 °C		200			200			500		ns
V _{SAT}	Saturation voltage	LM111/211 V _{IN} ≤ -5mV; I _{OUT} = 50 mA LM311/B V _{IN} ≤ -10 mV; I _{OUT} = 50 mA T _{amb} = 25 °C		0.75	1.5		0.75	1.5		0.75	1.5	V
I _{BAL/STR}	Strobe on current	T _{amb} = 25 °C		3.0			3.0			3.0		mA
I _{LEAKAGE}	Output leakage current ⁶	LM111/211 V _{IN} ≥ 5 mV; V _{OUT} = 35 V LM311/B V _{IN} ≥ 10 mV; V _{OUT} = 35 V T _{amb} = 25 °C, I _{STROBE} = 3 mA (V ₋ = V _{GND} = -5 V)		0.2	10		0.2	50		0.2	50	nA
V _{OS}	Input offset voltage ³	R _S ≤ 50 kΩ			4.0			10			10	mV
I _{OS}	Input offset current ³				20			70			50	nA
I _{BIAS}	Input bias current				150			300			250	nA
V _{IN}	Input voltage range	V = ±15 V (Pin 7 may go to 5 V)	-14.5	13.8 to -14.7	13.0	-14.5	13.8 to -14.7	13.0	V- +0.5		V+ -1.5	V
V _{OL}	Saturation voltage ⁶	V ₊ ≥ 4.5 V, V ₋ = 0 V LM111/211 V _{IN} ≤ -6 mV; I _{SINK} ≤ 8 mA LM311/B V _{IN} ≤ -10 mV; I _{SINK} ≤ 8 mA		0.23	0.4		0.23	0.4		0.23	0.4	V
I _{OH}	Output leakage current	V _{IN} ≥ 5 mV; V _{OUT} = 35 V		0.1	0.5							μA
I _{CC}	Positive supply current	T _{amb} = 25 °C		5.1	6.0		5.1	7.5		1.6	3.5	mA
I _{EE}	Negative supply voltage	T _{amb} = 25 °C		4.1	5.0		4.1	5.0				mA

NOTES:

1. This rating applies for ±15 V supplies. The positive input voltage limit is 30 V above the negative supply. The negative input voltage limit is equal to the negative supply voltage or 30 V below the positive supply, whichever is less.
2. These specifications apply for V_S = ±15 V and 0 °C < T_{amb} < 70 °C unless otherwise specified. With the LM211, however, all temperature specifications are limited to -25 °C ≤ T_{amb} ≤ +85 °C, for the AU211 is limited to -40 °C < T_{amb} < +125 °C, and for the LM111 is limited to -55 °C < T_{amb} < +125 °C. The offset voltage, offset current, and bias current specifications apply for any supply voltage from a single 5 V supply up to ±15 V supplies.
3. The offset voltages and offset currents given are the maximum values required to drive the output within a volt of either supply with 1 mA load. Thus, these parameters define an error band and take into account the worst case effects of voltage gain and input impedance.
4. The response time specified is for a 100 mV input step with 5 mV over-drive.
5. Do not short the strobe pin to ground; it should be current driven at 3 mA to 5 mA.
6. LM311B, all parameters are at V₊ = 3 V ±10%; V₋ = GND = 0 V.

Voltage comparator

AU211/LM111/211/311/311B

TYPICAL APPLICATIONS

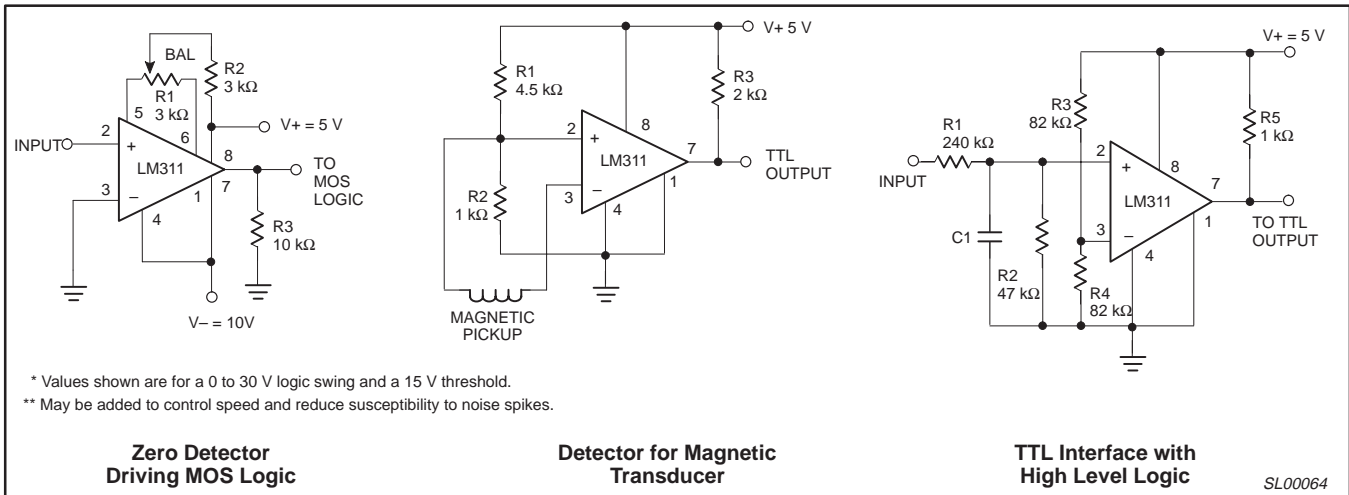

Figure 3. Typical Applications

Voltage comparator

AU211/LM111/211/311/311B

DIP8: plastic dual in-line package; 8 leads (300 mil)

SOT97-1

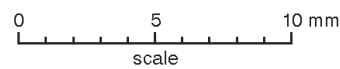
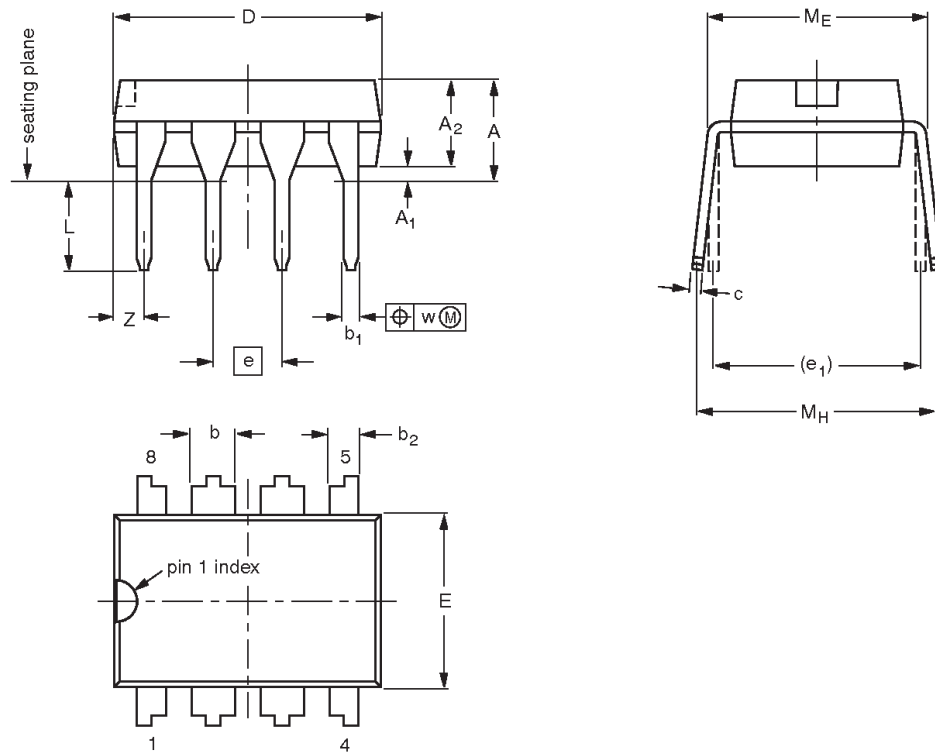

DIMENSIONS (inch dimensions are derived from the original mm dimensions)

UNIT	A max.	A ₁ min.	A ₂ max.	b	b ₁	b ₂	c	D ⁽¹⁾	E ⁽¹⁾	e	e ₁	L	M _E	M _H	w	Z ⁽¹⁾ max.
mm	4.2	0.51	3.2	1.73 1.14	0.53 0.38	1.07 0.89	0.36 0.23	9.8 9.2	6.48 6.20	2.54	7.62	3.60 3.05	8.25 7.80	10.0 8.3	0.254	1.15
inches	0.17	0.02	0.13	0.068 0.045	0.021 0.015	0.042 0.035	0.014 0.009	0.39 0.36	0.26 0.24	0.1	0.3	0.14 0.12	0.32 0.31	0.39 0.33	0.01	0.045

Note

1. Plastic or metal protrusions of 0.25 mm (0.01 inch) maximum per side are not included.

OUTLINE VERSION	REFERENCES				EUROPEAN PROJECTION	ISSUE DATE
	IEC	JEDEC	JEITA			
SOT97-1	050G01	MO-001	SC-504-8			99-12-27 03-02-13

Voltage comparator

AU211/LM111/211/311/311B

SO8: plastic small outline package; 8 leads; body width 3.9 mm

SOT96-1

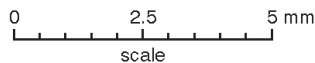
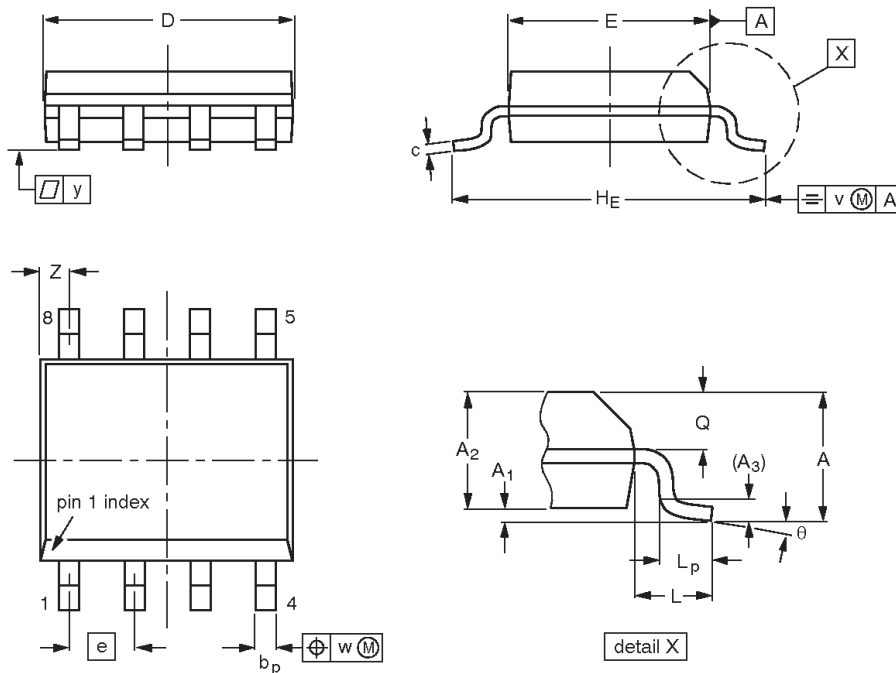

DIMENSIONS (inch dimensions are derived from the original mm dimensions)

UNIT	A max.	A ₁	A ₂	A ₃	b _p	c	D ⁽¹⁾	E ⁽²⁾	e	H _E	L	L _p	Q	v	w	y	Z ⁽¹⁾	θ
mm	1.75	0.25 0.10	1.45 1.25	0.25	0.49 0.36	0.25 0.19	5.0 4.8	4.0 3.8	1.27	6.2 5.8	1.05	1.0 0.4	0.7 0.6	0.25	0.25	0.1	0.7 0.3	8° 0°
inches	0.069	0.010 0.004	0.057 0.049	0.01	0.019 0.014	0.0100 0.0075	0.20 0.19	0.16 0.15	0.05	0.244 0.228	0.041	0.039 0.016	0.028 0.024	0.01	0.01	0.004	0.028 0.012	

Notes

1. Plastic or metal protrusions of 0.15 mm (0.006 inch) maximum per side are not included.
2. Plastic or metal protrusions of 0.25 mm (0.01 inch) maximum per side are not included.

OUTLINE VERSION	REFERENCES				EUROPEAN PROJECTION	ISSUE DATE
	IEC	JEDEC	JEITA			
SOT96-1	076E03	MS-012				99-12-27 03-02-18

Voltage comparator

AU211/LM111/211/311/311B

REVISION HISTORY

Rev	Date	Description
_3	20030930	Product data (9397 750 12106). ECN 853-0927 30378 of 26 September 2003. Replaces LM111_211_311_311B_2 (9397 750 09216) of 2001 Aug 03. Modifications: <ul style="list-style-type: none"> • Add Type number AU211. • DC electrical characteristics, Note 2, on page 4: add "for the AU211 is limited to $-40\text{ }^{\circ}\text{C} < T_{\text{amb}} < +125\text{ }^{\circ}\text{C}$".
_2	20010803	Product data (9397 750 09216). ECN 853-0927 26834 of 03 August 2001. Supersedes data of 1994 Aug 31.

Data sheet status

Level	Data sheet status ^[1]	Product status ^{[2] [3]}	Definitions
I	Objective data	Development	This data sheet contains data from the objective specification for product development. Philips Semiconductors reserves the right to change the specification in any manner without notice.
II	Preliminary data	Qualification	This data sheet contains data from the preliminary specification. Supplementary data will be published at a later date. Philips Semiconductors reserves the right to change the specification without notice, in order to improve the design and supply the best possible product.
III	Product data	Production	This data sheet contains data from the product specification. Philips Semiconductors reserves the right to make changes at any time in order to improve the design, manufacturing and supply. Relevant changes will be communicated via a Customer Product/Process Change Notification (CPCN).

[1] Please consult the most recently issued data sheet before initiating or completing a design.

[2] The product status of the device(s) described in this data sheet may have changed since this data sheet was published. The latest information is available on the Internet at URL <http://www.semiconductors.philips.com>.

[3] For data sheets describing multiple type numbers, the highest-level product status determines the data sheet status.

Definitions

Short-form specification — The data in a short-form specification is extracted from a full data sheet with the same type number and title. For detailed information see the relevant data sheet or data handbook.

Limiting values definition — Limiting values given are in accordance with the Absolute Maximum Rating System (IEC 60134). Stress above one or more of the limiting values may cause permanent damage to the device. These are stress ratings only and operation of the device at these or at any other conditions above those given in the Characteristics sections of the specification is not implied. Exposure to limiting values for extended periods may affect device reliability.

Application information — Applications that are described herein for any of these products are for illustrative purposes only. Philips Semiconductors make no representation or warranty that such applications will be suitable for the specified use without further testing or modification.

Disclaimers

Life support — These products are not designed for use in life support appliances, devices, or systems where malfunction of these products can reasonably be expected to result in personal injury. Philips Semiconductors customers using or selling these products for use in such applications do so at their own risk and agree to fully indemnify Philips Semiconductors for any damages resulting from such application.

Right to make changes — Philips Semiconductors reserves the right to make changes in the products—including circuits, standard cells, and/or software—described or contained herein in order to improve design and/or performance. When the product is in full production (status 'Production'), relevant changes will be communicated via a Customer Product/Process Change Notification (CPCN). Philips Semiconductors assumes no responsibility or liability for the use of any of these products, conveys no license or title under any patent, copyright, or mask work right to these products, and makes no representations or warranties that these products are free from patent, copyright, or mask work right infringement, unless otherwise specified.

Contact information

For additional information please visit
<http://www.semiconductors.philips.com>. Fax: +31 40 27 24825

© Koninklijke Philips Electronics N.V. 2003
 All rights reserved. Printed in U.S.A.

Date of release: 09-03

For sales offices addresses send e-mail to:
sales.addresses@www.semiconductors.philips.com

Document order number:

9397 750 12106

Let's make things better.