

LF353-N Wide Bandwidth Dual JFET Input Operational Amplifier

 Check for Samples: [LF353-N](#)

FEATURES

- **Internally Trimmed Offset Voltage: 10 mV**
- **Low Input Bias Current: 50pA**
- **Low Input Noise Voltage: 25 nV/√Hz**
- **Low Input Noise Current: 0.01 pA/√Hz**
- **Wide Gain Bandwidth: 4 MHz**
- **High Slew Rate: 13 V/μs**
- **Low Supply Current: 3.6 mA**
- **High Input Impedance: 10¹²Ω**
- **Low Total Harmonic Distortion : ≤0.02%**
- **Low 1/f Noise Corner: 50 Hz**
- **Fast Settling Time to 0.01%: 2 μs**

DESCRIPTION

These devices are low cost, high speed, dual JFET input operational amplifiers with an internally trimmed input offset voltage (BI-FET II technology). They require low supply current yet maintain a large gain bandwidth product and fast slew rate. In addition, well matched high voltage JFET input devices provide very low input bias and offset currents. The LF353-N is pin compatible with the standard LM1558 allowing designers to immediately upgrade the overall performance of existing LM1558 and LM358 designs.

These amplifiers may be used in applications such as high speed integrators, fast D/A converters, sample and hold circuits and many other circuits requiring low input offset voltage, low input bias current, high input impedance, high slew rate and wide bandwidth. The devices also exhibit low noise and offset voltage drift.

Typical Connection

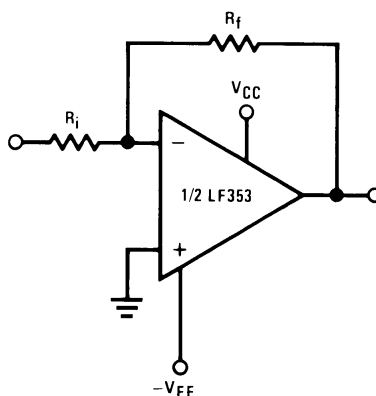

Please be aware that an important notice concerning availability, standard warranty, and use in critical applications of Texas Instruments semiconductor products and disclaimers thereto appears at the end of this data sheet.

All trademarks are the property of their respective owners.

Simplified Schematic

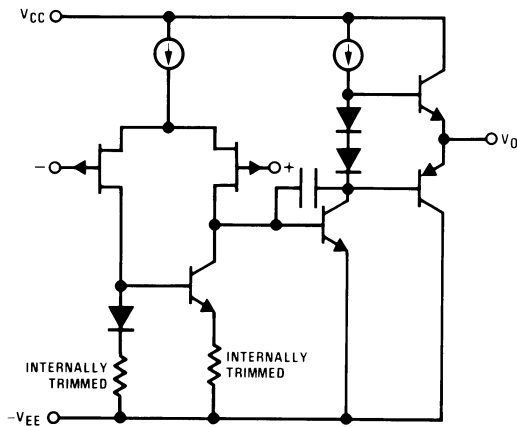
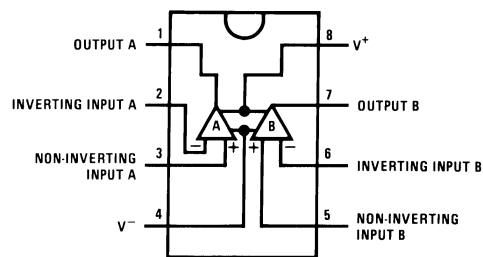

Figure 1. 1/2 Dual

**Dual-In-Line Package
Top View**



**Figure 2. 8-Pin SOIC (See D Package)
8-Pin PDIP (See P Package)**



These devices have limited built-in ESD protection. The leads should be shorted together or the device placed in conductive foam during storage or handling to prevent electrostatic damage to the MOS gates.

Absolute Maximum Ratings⁽¹⁾⁽²⁾

| | | |
|---|-----------------------|--------------------|
| Supply Voltage | | ±18V |
| Power Dissipation | | See ⁽³⁾ |
| Operating Temperature Range | | 0°C to +70°C |
| T _J (MAX) | | 150°C |
| Differential Input Voltage | | ±30V |
| Input Voltage Range ⁽⁴⁾ | | ±15V |
| Output Short Circuit Duration | | Continuous |
| Storage Temperature Range | | -65°C to +150°C |
| Lead Temp. (Soldering, 10 sec.) | | 260°C |
| Soldering Information: Dual-In-Line Package Soldering (10 sec.) | | 260°C |
| Small Outline Package | Vapor Phase (60 sec.) | 215°C |
| | Infrared (15 sec.) | 220°C |
| ESD Tolerance ⁽⁵⁾ | | 1000V |
| θ _{JA} D Package | | TBD |

- (1) Absolute Maximum Ratings indicate limits beyond which damage to the device may occur. Operating ratings indicate conditions for which the device is functional, but do not ensure specific performance limits. Electrical Characteristics state DC and AC electrical specifications under particular test conditions which ensure specific performance limits. This assumes that the device is within the Operating Ratings. Specifications are not ensured for parameters where no limit is given, however, the typical value is a good indication of device performance.
- (2) If Military/Aerospace specified devices are required, please contact the Texas Instruments Sales Office/ Distributors for availability and specifications.
- (3) For operating at elevated temperatures, the device must be derated based on a thermal resistance of 115°C/W typ junction to ambient for the P package, and 160°C/W typ junction to ambient for the D package.
- (4) Unless otherwise specified the absolute maximum negative input voltage is equal to the negative power supply voltage.
- (5) Human body model, 1.5 kΩ in series with 100 pF.

DC Electrical Characteristics

| Symbol | Parameter | Conditions | LF353-N | | | Units |
|--------------------------|------------------------------------|--|----------|------------|-----|------------------|
| | | | Min | Typ | Max | |
| V_{OS} | Input Offset Voltage | $R_S=10k\Omega$, $T_A=25^\circ C$ Over Temperature | | 5 | 10 | mV |
| | | | | | 13 | mV |
| $\Delta V_{OS}/\Delta T$ | Average TC of Input Offset Voltage | $R_S=10k\Omega$ | | 10 | | $\mu V/^\circ C$ |
| I_{OS} | Input Offset Current | $T_j=25^\circ C^{(1)(2)}$ | | 25 | 100 | pA |
| | | $T_j \leq 70^\circ C$ | | | 4 | nA |
| I_B | Input Bias Current | $T_j=25^\circ C^{(1)(2)}$ | | 50 | 200 | pA |
| | | $T_j \leq 70^\circ C$ | | | 8 | nA |
| R_{IN} | Input Resistance | $T_j=25^\circ C$ | | 10^{12} | | Ω |
| A_{VOL} | Large Signal Voltage Gain | $V_S=\pm 15V$, $T_A=25^\circ C$ | 25 | 100 | | V/mV |
| | | $V_O=\pm 10V$, $R_L=2k\Omega$ | | | | |
| | | Over Temperature | 15 | | | V/mV |
| V_O | Output Voltage Swing | $V_S=\pm 15V$, $R_L=10k\Omega$ | ± 12 | ± 13.5 | | V |
| V_{CM} | Input Common-Mode Voltage | $V_S=\pm 15V$ | ± 11 | +15 | | V |
| | Range | | | -12 | | V |
| CMRR | Common-Mode Rejection Ratio | $R_S \leq 10k\Omega$ | 70 | 100 | | dB |
| PSRR | Supply Voltage Rejection Ratio | See ⁽³⁾ | 70 | 100 | | dB |
| I_S | Supply Current | | | 3.6 | 6.5 | mA |

- (1) These specifications apply for $V_S=\pm 15V$ and $0^\circ C \leq T_A \leq +70^\circ C$. V_{OS} , I_B and I_{OS} are measured at $V_{CM}=0$.
- (2) The input bias currents are junction leakage currents which approximately double for every $10^\circ C$ increase in the junction temperature, T_j . Due to the limited production test time, the input bias currents measured are correlated to junction temperature. In normal operation the junction temperature rises above the ambient temperature as a result of internal power dissipation, P_D . $T_j=T_A+\theta_{JA} P_D$ where θ_{JA} is the thermal resistance from junction to ambient. Use of a heat sink is recommended if input bias current is to be kept to a minimum.
- (3) Supply voltage rejection ratio is measured for both supply magnitudes increasing or decreasing simultaneously in accordance with common practice. $V_S = \pm 6V$ to $\pm 15V$.

AC Electrical Characteristics⁽¹⁾

| Symbol | Parameter | Conditions | LF353-N | | | Units |
|--------|---------------------------------|---|---------|-------|-----|-----------------|
| | | | Min | Typ | Max | |
| | Amplifier to Amplifier Coupling | $T_A=25^\circ C$, $f=1\text{ Hz}-20\text{ kHz}$ (Input Referred) | | -120 | | dB |
| SR | Slew Rate | $V_S=\pm 15V$, $T_A=25^\circ C$ | 8.0 | 13 | | V/ μs |
| GBW | Gain Bandwidth Product | $V_S=\pm 15V$, $T_A=25^\circ C$ | 2.7 | 4 | | MHz |
| e_n | Equivalent Input Noise Voltage | $T_A=25^\circ C$, $R_S=100\Omega$, $f=1000\text{ Hz}$ | | 16 | | nV/ \sqrt{Hz} |
| i_n | Equivalent Input Noise Current | $T_j=25^\circ C$, $f=1000\text{ Hz}$ | | 0.01 | | pA/ \sqrt{Hz} |
| THD | Total Harmonic Distortion | $A_V=+10$, $R_L=10k$, $V_O=20Vp-p$, $BW=20\text{ Hz}-20\text{ kHz}$ | | <0.02 | | % |

- (1) These specifications apply for $V_S=\pm 15V$ and $0^\circ C \leq T_A \leq +70^\circ C$. V_{OS} , I_B and I_{OS} are measured at $V_{CM}=0$.

Typical Performance Characteristics

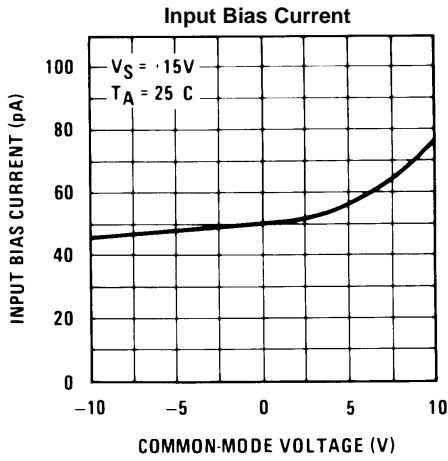

Figure 3.

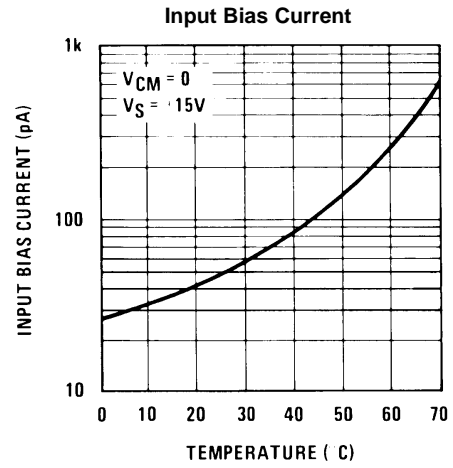

Figure 4.

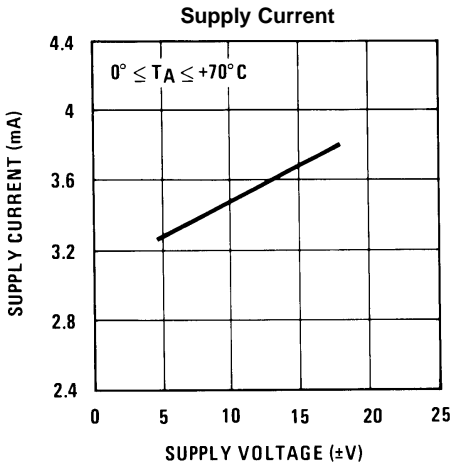

Figure 5.

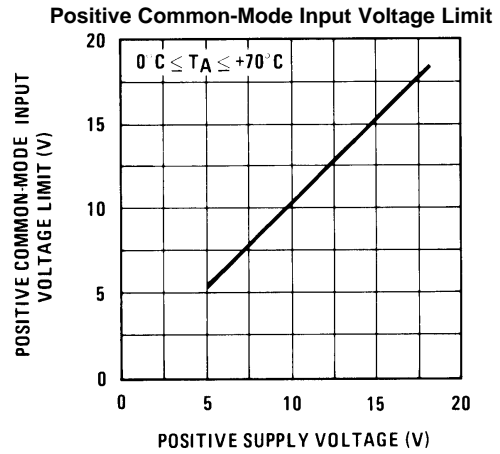

Figure 6.

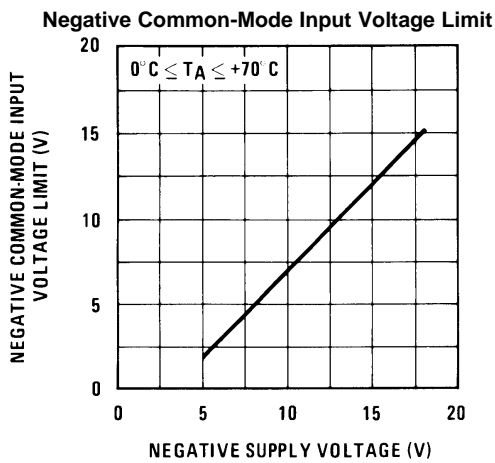

Figure 7.

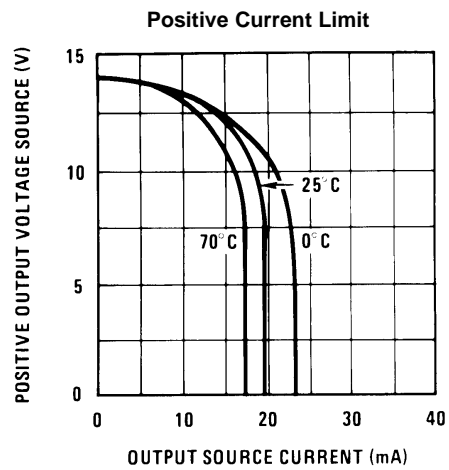

Figure 8.

Typical Performance Characteristics (continued)

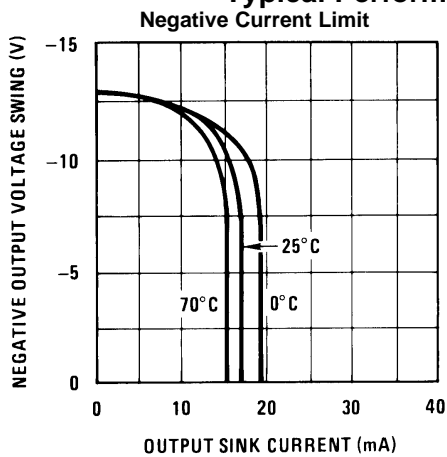

Figure 9.

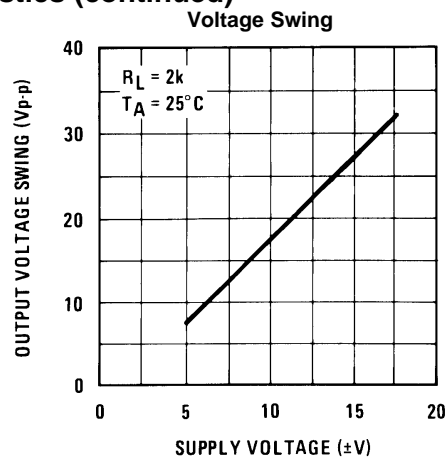

Figure 10.

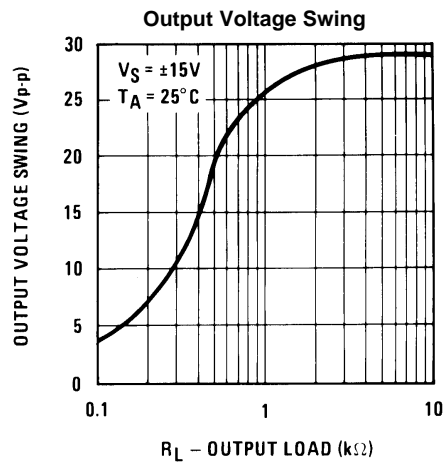

Figure 11.

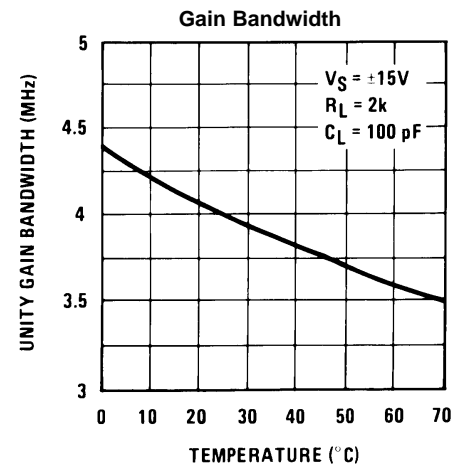

Figure 12.

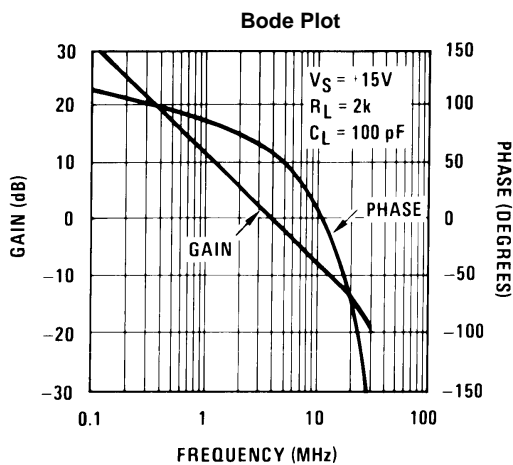

Figure 13.

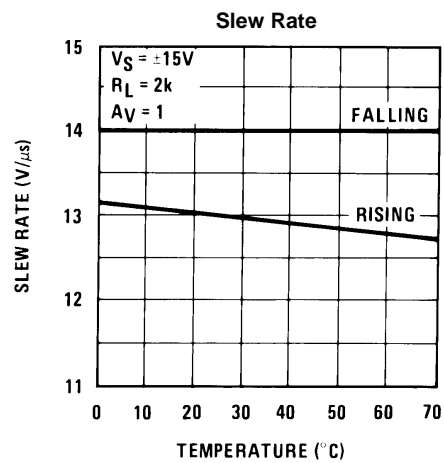

Figure 14.

Typical Performance Characteristics (continued)

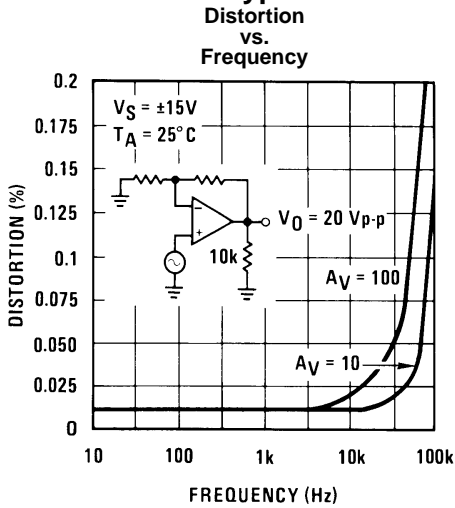

Figure 15.

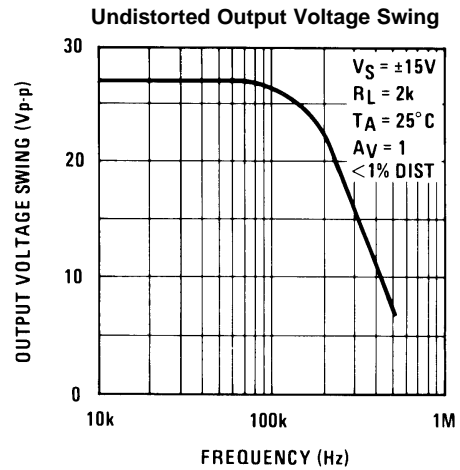

Figure 16.

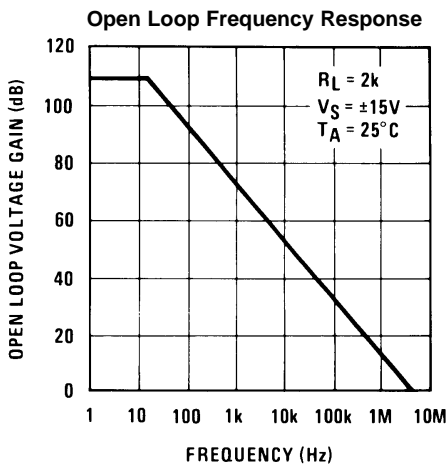

Figure 17.

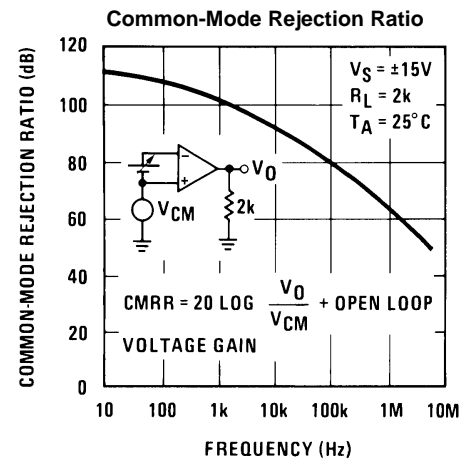

Figure 18.

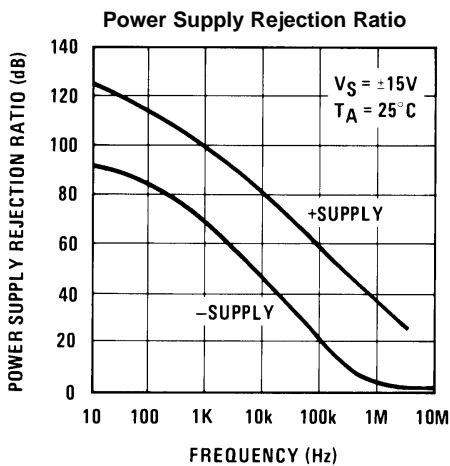

Figure 19.

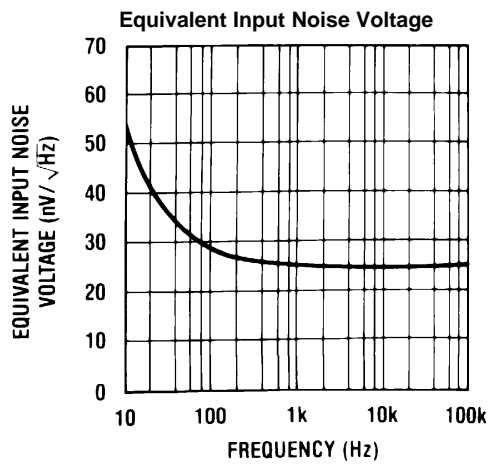

Figure 20.

Typical Performance Characteristics (continued)

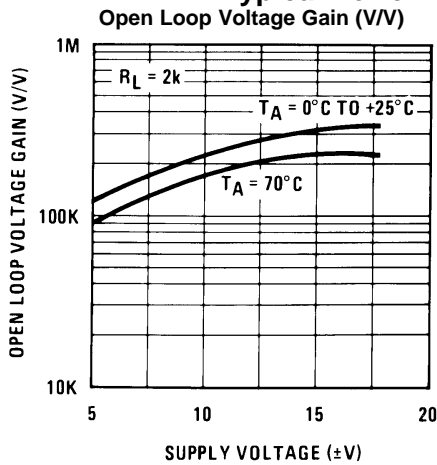

Figure 21.

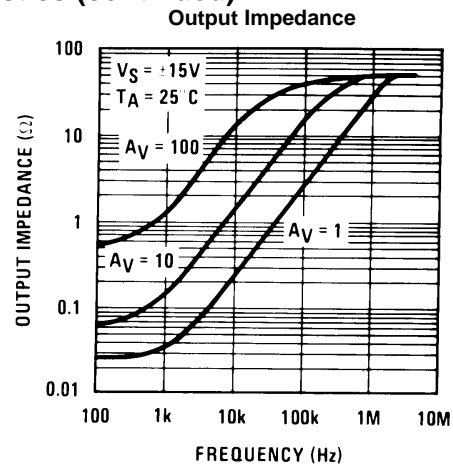

Figure 22.

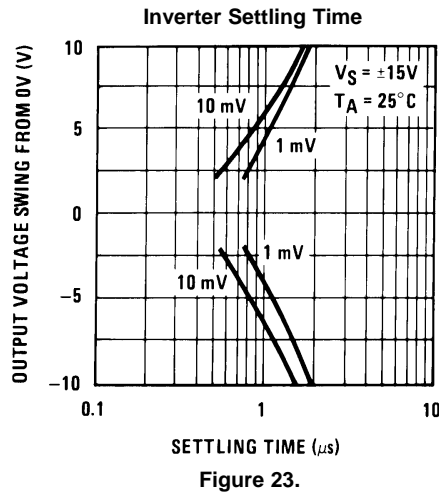

Figure 23.

Pulse Response

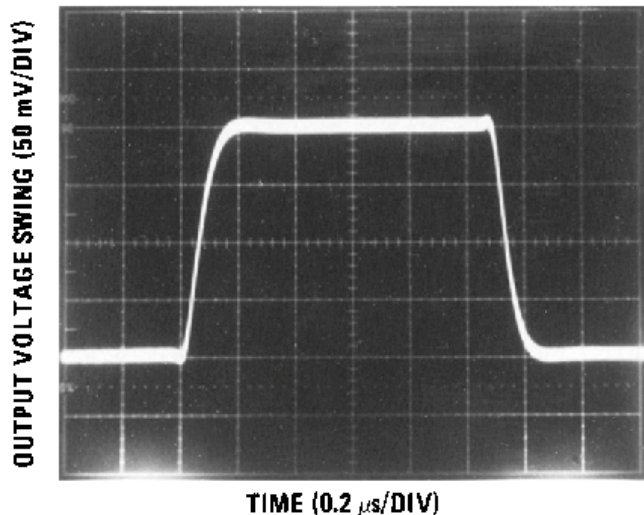

Figure 24. Small Signaling Inverting

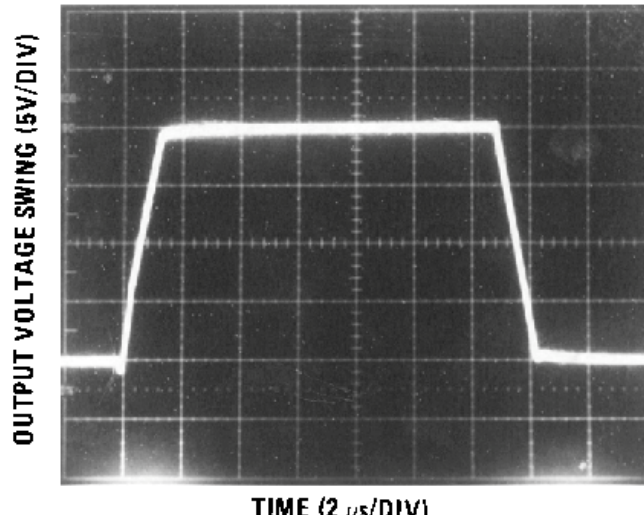

Figure 25. Large Signal Inverting

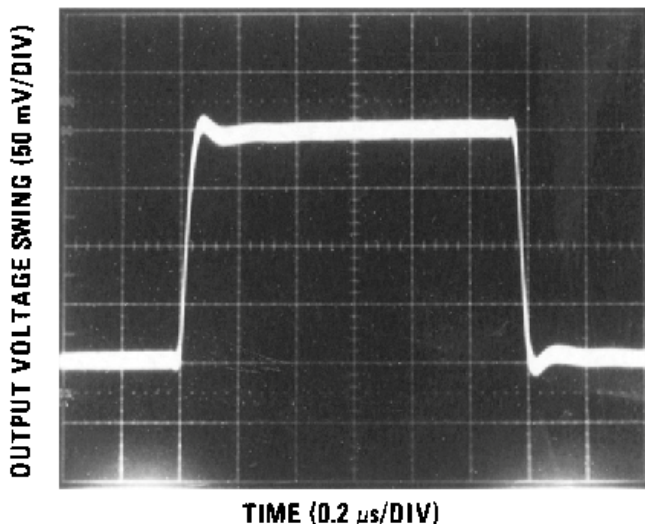

Figure 26. Small Signal Non-Inverting

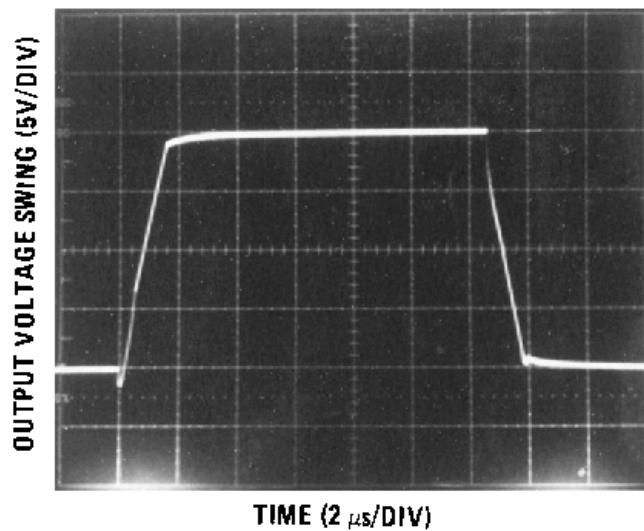

Figure 27. Large Signal Non-Inverting

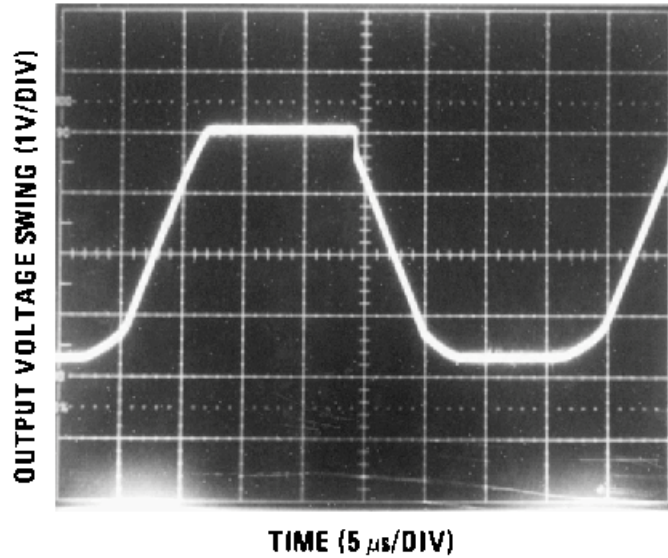

Figure 28. Current Limit ($R_L = 100\Omega$)

APPLICATION HINTS

These devices are op amps with an internally trimmed input offset voltage and JFET input devices (BI-FET II). These JFETs have large reverse breakdown voltages from gate to source and drain eliminating the need for clamps across the inputs. Therefore, large differential input voltages can easily be accommodated without a large increase in input current. The maximum differential input voltage is independent of the supply voltages. However, neither of the input voltages should be allowed to exceed the negative supply as this will cause large currents to flow which can result in a destroyed unit.

Exceeding the negative common-mode limit on either input will force the output to a high state, potentially causing a reversal of phase to the output. Exceeding the negative common-mode limit on both inputs will force the amplifier output to a high state. In neither case does a latch occur since raising the input back within the common-mode range again puts the input stage and thus the amplifier in a normal operating mode.

Exceeding the positive common-mode limit on a single input will not change the phase of the output; however, if both inputs exceed the limit, the output of the amplifier will be forced to a high state.

The amplifiers will operate with a common-mode input voltage equal to the positive supply; however, the gain bandwidth and slew rate may be decreased in this condition. When the negative common-mode voltage swings to within 3V of the negative supply, an increase in input offset voltage may occur.

Each amplifier is individually biased by a zener reference which allows normal circuit operation on $\pm 6V$ power supplies. Supply voltages less than these may result in lower gain bandwidth and slew rate.

The amplifiers will drive a 2 k Ω load resistance to $\pm 10V$ over the full temperature range of 0°C to +70°C. If the amplifier is forced to drive heavier load currents, however, an increase in input offset voltage may occur on the negative voltage swing and finally reach an active current limit on both positive and negative swings.

Precautions should be taken to ensure that the power supply for the integrated circuit never becomes reversed in polarity or that the unit is not inadvertently installed backwards in a socket as an unlimited current surge through the resulting forward diode within the IC could cause fusing of the internal conductors and result in a destroyed unit.

As with most amplifiers, care should be taken with lead dress, component placement and supply decoupling in order to ensure stability. For example, resistors from the output to an input should be placed with the body close to the input to minimize “pick-up” and maximize the frequency of the feedback pole by minimizing the capacitance from the input to ground.

A feedback pole is created when the feedback around any amplifier is resistive. The parallel resistance and capacitance from the input of the device (usually the inverting input) to AC ground set the frequency of the pole. In many instances the frequency of this pole is much greater than the expected 3 dB frequency of the closed loop gain and consequently there is negligible effect on stability margin. However, if the feedback pole is less than approximately 6 times the expected 3 dB frequency a lead capacitor should be placed from the output to the input of the op amp. The value of the added capacitor should be such that the RC time constant of this capacitor and the resistance it parallels is greater than or equal to the original feedback pole time constant.

Detailed Schematic

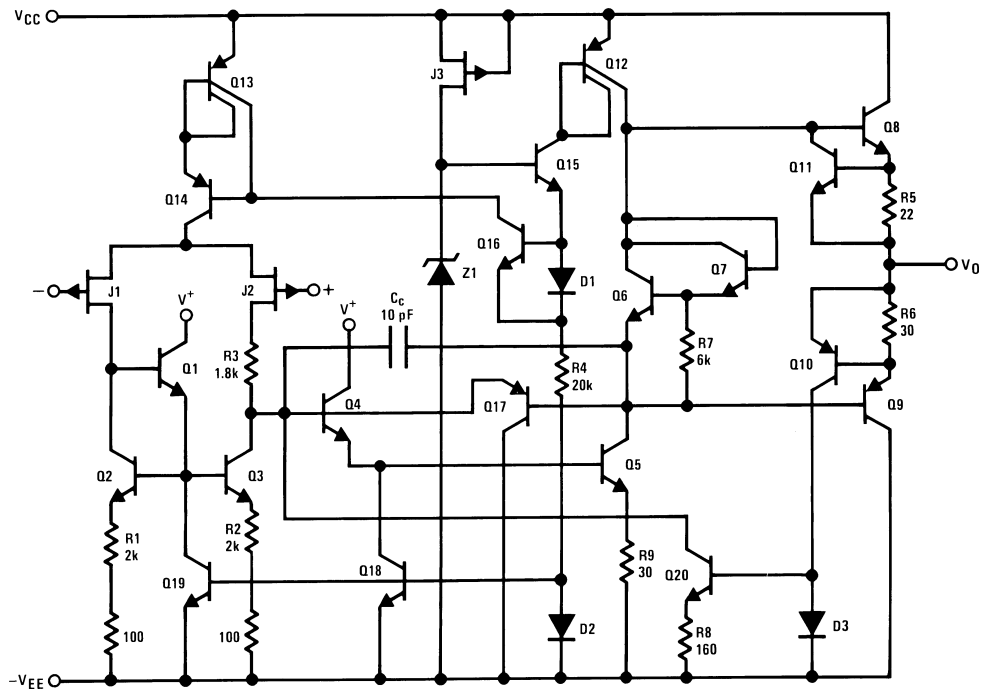

Typical Applications

Three-Band Active Tone Control

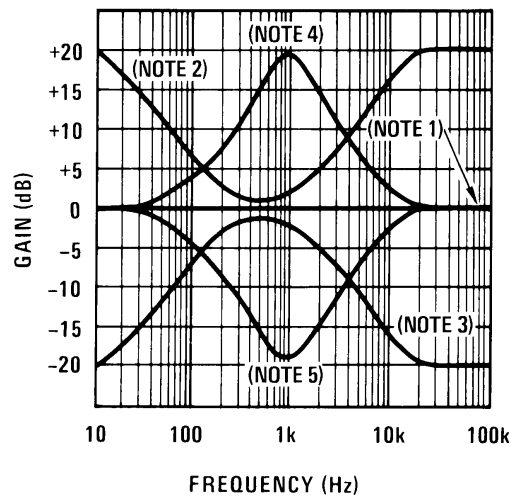
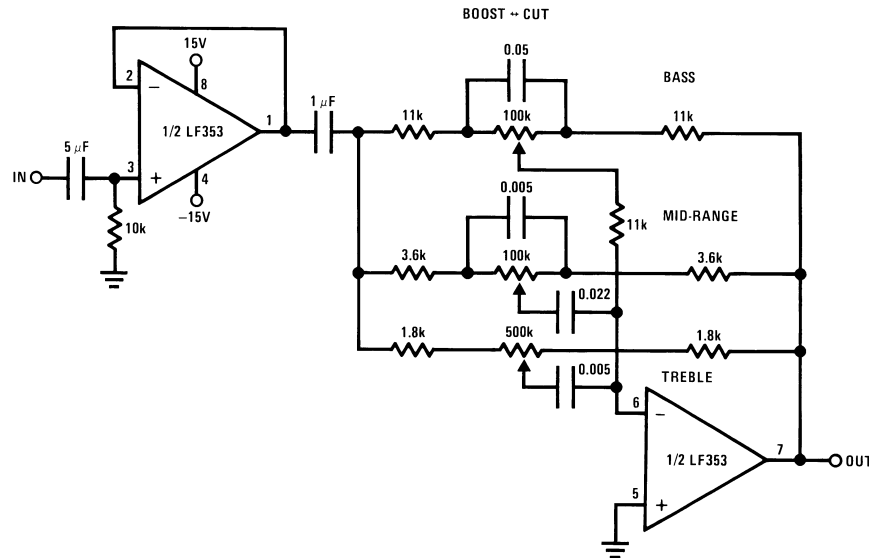

- (1) All controls flat.
- (2) Bass and treble boost, mid flat.
- (3) Bass and treble cut, mid flat.
- (4) Mid boost, bass and treble flat.
- (5) Mid cut, bass and treble flat.
 - All potentiometers are linear taper
 - Use the LF347 Quad for stereo applications

Improved CMRR Instrumentation Amplifier

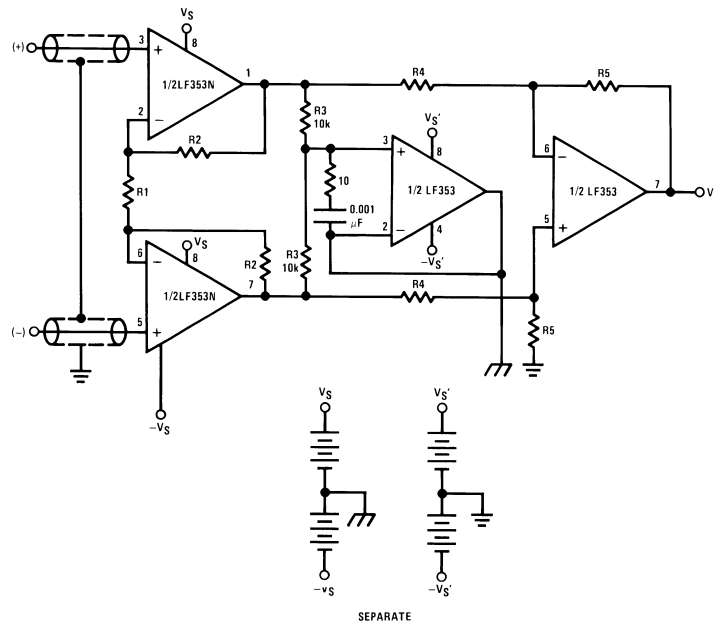

$$A_V = \left(\frac{2R_2}{R_1} + 1 \right) \frac{R_5}{R_4}$$

⏏ and ⏏ are separate isolated grounds
 Matching of R2's, R4's and R5's control CMRR
 With $A_{V_T} = 1400$, resistor matching = 0.01%: CMRR = 136 dB

- Very high input impedance
- Super high CMRR

(1)

Fourth Order Low Pass Butterworth Filter

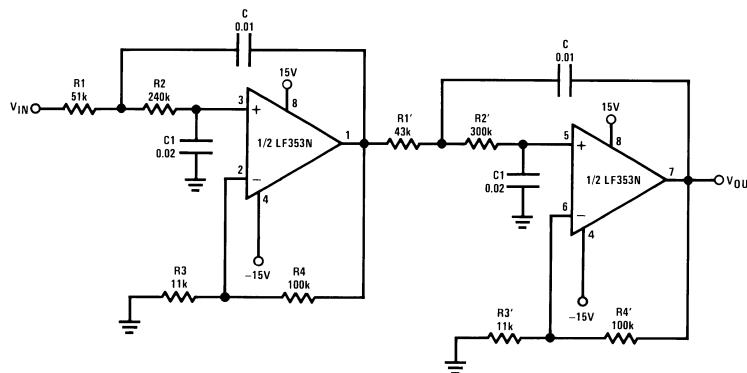

- Corner frequency (f_c) = $\sqrt{\frac{1}{R_1 R_2 C C_1}} \cdot \frac{1}{2\pi} = \sqrt{\frac{1}{R_1' R_2' C C_1}} \cdot \frac{1}{2\pi}$
- Passband gain (H_O) = $(1 + R_4/R_3) (1 + R_4'/R_3')$
- First stage Q = 1.31
- Second stage Q = 0.541
- Circuit shown uses nearest 5% tolerance resistor values for a filter with a corner frequency of 100 Hz and a passband gain of 100
- Offset nulling necessary for accurate DC performance

(2)

Fourth Order High Pass Butterworth Filter

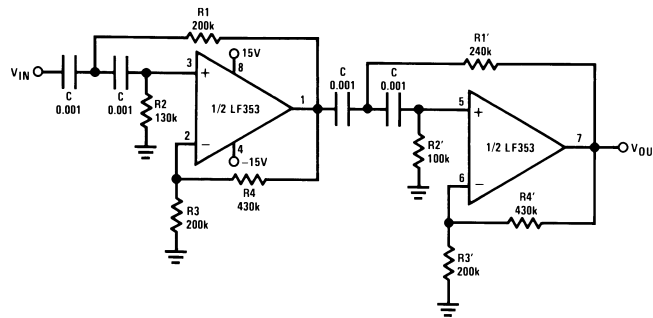

- Corner frequency (f_c) = $\sqrt{\frac{1}{R_1 R_2 C^2}} \cdot \frac{1}{2\pi} = \sqrt{\frac{1}{R_1' R_2' C^2}} \cdot \frac{1}{2\pi}$
- Passband gain (H_0) = $(1 + R_4/R_3) (1 + R_4'/R_3')$
- First stage Q = 1.31
- Second stage Q = 0.541
- Circuit shown uses closest 5% tolerance resistor values for a filter with a corner frequency of 1 kHz and a passband gain of 10.

(3)

Ohms-to-Volts Converter

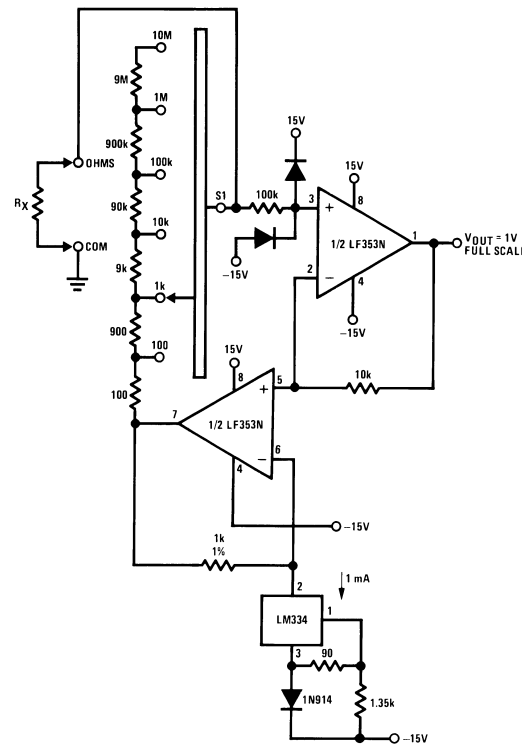

$$V_O = \frac{1V}{R_{LADDER}} \times R_X$$

Where R_{LADDER} is the resistance from switch S1 pole to pin 7 of the LF353.

(4)

REVISION HISTORY

| Changes from Revision E (March 2013) to Revision F | Page |
|--|--------------------|
| • Changed layout of National Data Sheet to TI format | 15 |

IMPORTANT NOTICE

Texas Instruments Incorporated and its subsidiaries (TI) reserve the right to make corrections, enhancements, improvements and other changes to its semiconductor products and services per JESD46, latest issue, and to discontinue any product or service per JESD48, latest issue. Buyers should obtain the latest relevant information before placing orders and should verify that such information is current and complete. All semiconductor products (also referred to herein as "components") are sold subject to TI's terms and conditions of sale supplied at the time of order acknowledgment.

TI warrants performance of its components to the specifications applicable at the time of sale, in accordance with the warranty in TI's terms and conditions of sale of semiconductor products. Testing and other quality control techniques are used to the extent TI deems necessary to support this warranty. Except where mandated by applicable law, testing of all parameters of each component is not necessarily performed.

TI assumes no liability for applications assistance or the design of Buyers' products. Buyers are responsible for their products and applications using TI components. To minimize the risks associated with Buyers' products and applications, Buyers should provide adequate design and operating safeguards.

TI does not warrant or represent that any license, either express or implied, is granted under any patent right, copyright, mask work right, or other intellectual property right relating to any combination, machine, or process in which TI components or services are used. Information published by TI regarding third-party products or services does not constitute a license to use such products or services or a warranty or endorsement thereof. Use of such information may require a license from a third party under the patents or other intellectual property of the third party, or a license from TI under the patents or other intellectual property of TI.

Reproduction of significant portions of TI information in TI data books or data sheets is permissible only if reproduction is without alteration and is accompanied by all associated warranties, conditions, limitations, and notices. TI is not responsible or liable for such altered documentation. Information of third parties may be subject to additional restrictions.

Resale of TI components or services with statements different from or beyond the parameters stated by TI for that component or service voids all express and any implied warranties for the associated TI component or service and is an unfair and deceptive business practice. TI is not responsible or liable for any such statements.

Buyer acknowledges and agrees that it is solely responsible for compliance with all legal, regulatory and safety-related requirements concerning its products, and any use of TI components in its applications, notwithstanding any applications-related information or support that may be provided by TI. Buyer represents and agrees that it has all the necessary expertise to create and implement safeguards which anticipate dangerous consequences of failures, monitor failures and their consequences, lessen the likelihood of failures that might cause harm and take appropriate remedial actions. Buyer will fully indemnify TI and its representatives against any damages arising out of the use of any TI components in safety-critical applications.

In some cases, TI components may be promoted specifically to facilitate safety-related applications. With such components, TI's goal is to help enable customers to design and create their own end-product solutions that meet applicable functional safety standards and requirements. Nonetheless, such components are subject to these terms.

No TI components are authorized for use in FDA Class III (or similar life-critical medical equipment) unless authorized officers of the parties have executed a special agreement specifically governing such use.

Only those TI components which TI has specifically designated as military grade or "enhanced plastic" are designed and intended for use in military/aerospace applications or environments. Buyer acknowledges and agrees that any military or aerospace use of TI components which have **not** been so designated is solely at the Buyer's risk, and that Buyer is solely responsible for compliance with all legal and regulatory requirements in connection with such use.

TI has specifically designated certain components as meeting ISO/TS16949 requirements, mainly for automotive use. In any case of use of non-designated products, TI will not be responsible for any failure to meet ISO/TS16949.

Products

| | |
|------------------------------|--|
| Audio | www.ti.com/audio |
| Amplifiers | amplifier.ti.com |
| Data Converters | dataconverter.ti.com |
| DLP® Products | www.dlp.com |
| DSP | dsp.ti.com |
| Clocks and Timers | www.ti.com/clocks |
| Interface | interface.ti.com |
| Logic | logic.ti.com |
| Power Mgmt | power.ti.com |
| Microcontrollers | microcontroller.ti.com |
| RFID | www.ti-rfid.com |
| OMAP Applications Processors | www.ti.com/omap |
| Wireless Connectivity | www.ti.com/wirelessconnectivity |

Applications

| | |
|-------------------------------|--|
| Automotive and Transportation | www.ti.com/automotive |
| Communications and Telecom | www.ti.com/communications |
| Computers and Peripherals | www.ti.com/computers |
| Consumer Electronics | www.ti.com/consumer-apps |
| Energy and Lighting | www.ti.com/energy |
| Industrial | www.ti.com/industrial |
| Medical | www.ti.com/medical |
| Security | www.ti.com/security |
| Space, Avionics and Defense | www.ti.com/space-avionics-defense |
| Video and Imaging | www.ti.com/video |

TI E2E Community

e2e.ti.com