



## LD29080 series

800mA Fixed and adjustable output  
very low drop voltage regulator

### Features

- Very low dropout voltage (Typ. 0.4 at 800mA)
- Guaranteed output current up to 800mA
- Fixed and adjustable output voltage ( $\pm 1\%$  at 25°C)
- Internal current and thermal limit
- Logic controlled electronic shutdown

### Description

The LD29080 is a high current, high accuracy, low-dropout voltage regulators series. These regulators feature 400mV dropout voltages and very low ground current. Designed for high current loads, these devices also find applications in lower current, extremely low dropout-critical systems, where their tiny dropout voltage and ground current values are important attributes. Typical application are in Power supply switching

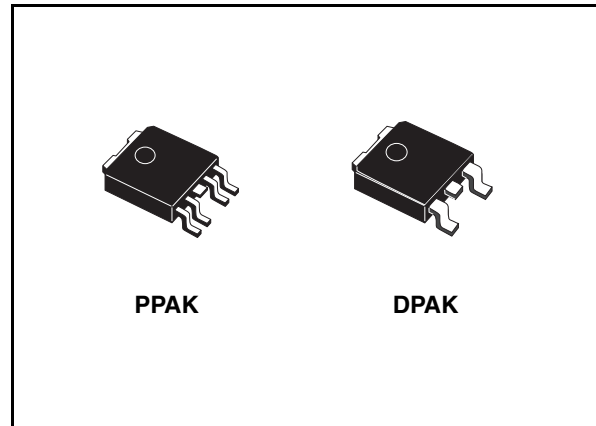

post regulation, Series power supply for monitors, Series power supply for VCRs and TVs, Computer Systems and Battery powered systems.

### Order codes

Part numbers		Output voltage
Packages		
DPAK (T&R)	PPAK (T&R)	
LD29080DT15R	LD29080PT15R	1.5 V
LD29080DT18R	LD29080PT18R	1.8 V <sup>(1)</sup>
LD29080DT25R	LD29080PT25R	2.5 V
LD29080DT33R	LD29080PT33R	3.3 V
LD29080DT50R	LD29080PT50R	5.0 V
LD29080DT80R	LD29080PT80R	8.0 V <sup>(1)</sup>
	LD29080PTR	ADJ

1. Available on request.

---

## Contents

1	Diagram .....	3
2	Pin configuration .....	4
3	Maximum ratings .....	5
4	Electrical characteristics .....	6
5	Typical characteristics .....	13
6	Package mechanical data .....	16
7	Revision history .....	20

# 1 Diagram

Figure 1. Schematic diagram for adjustable version

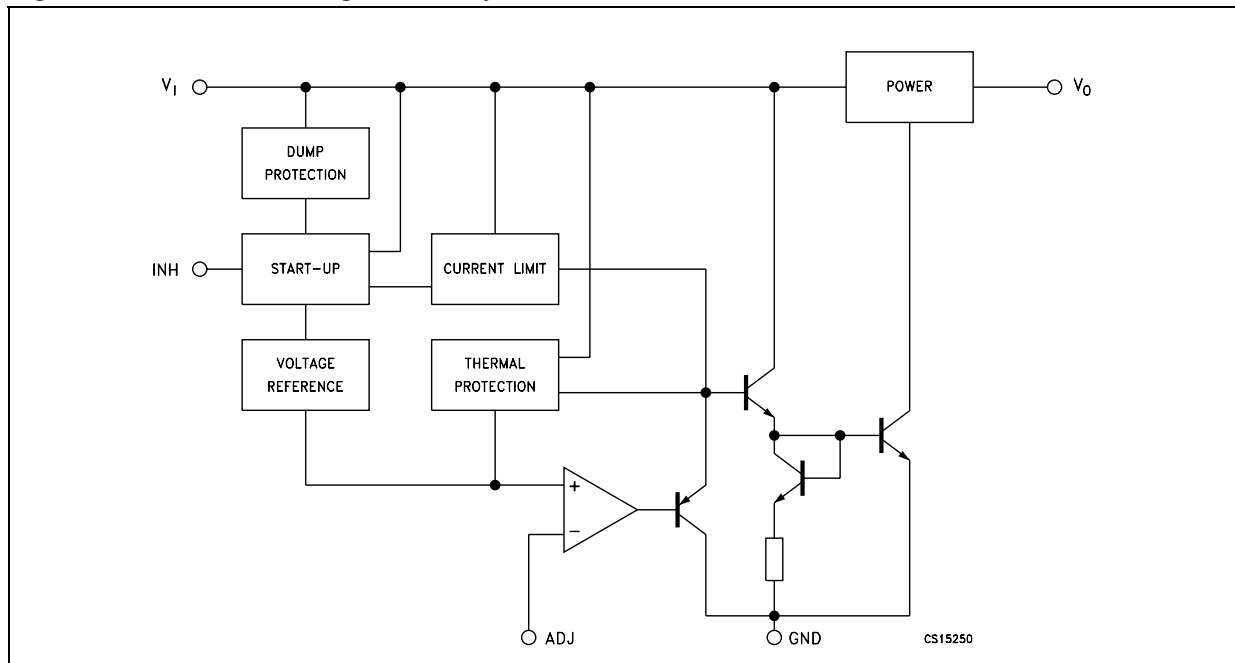
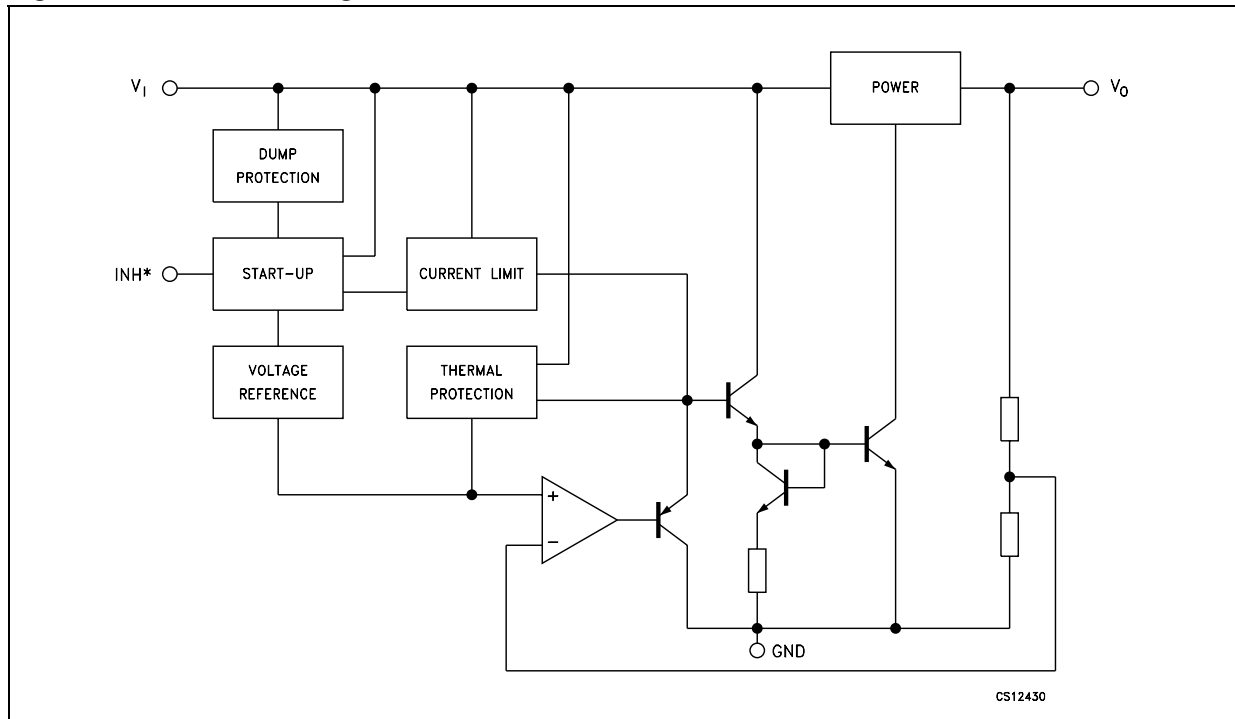

Figure 2. Schematic diagram for fixed version



\* Only for version with inhibit function.

## 2 Pin configuration

Figure 3. Pin connections (top view)

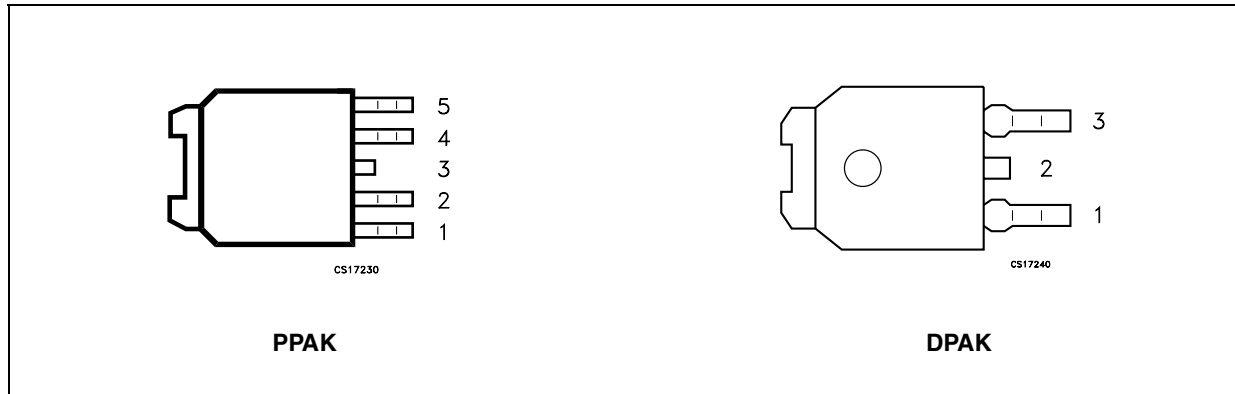
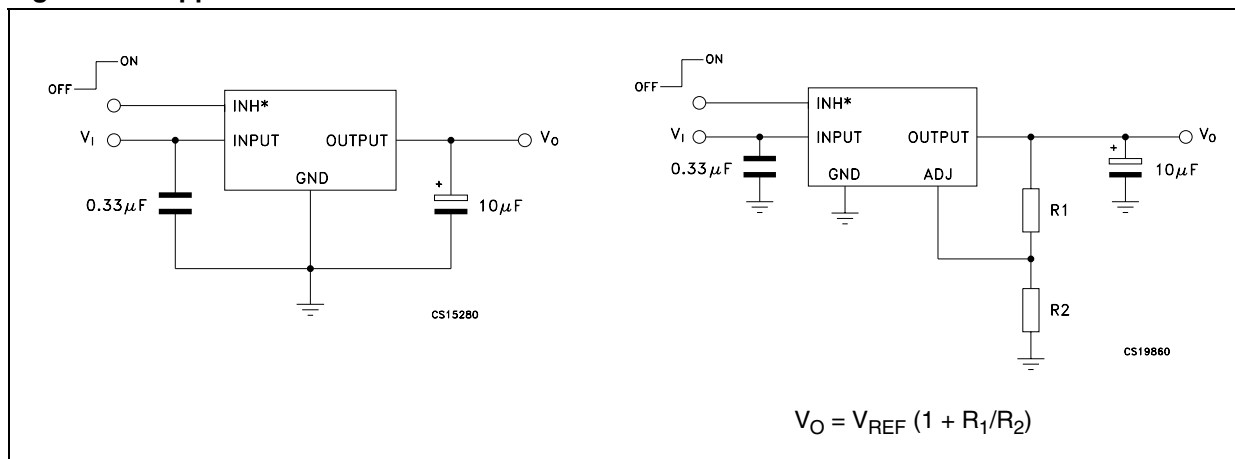

Table 1. Pin description

Symbol	PPAK	DPAK
$V_I$	2	1
GND	3	2
$V_O$	4	3
ADJ/N.C. <sup>(1)</sup>	5	
INHIBIT <sup>(2)</sup>	1	

1. Not connect for fixed version.
2. Not internally pulled up; in order to assure the operating condition (device in ON mode), it must be connected to a positive voltage higher than 2V.

Figure 4. Application circuit



\* Only for version with inhibit function.

### 3 Maximum ratings

**Table 2. Absolute maximum ratings**

Symbol	Parameter	Value	Unit
$V_I$	DC Input Voltage	30 <sup>(1)</sup>	V
$V_{INH}$	Inhibit Input Voltage	14	V
$I_O$	Output Current	Internally Limited	mA
$P_D$	Power Dissipation	Internally Limited	mW
$T_{STG}$	Storage Temperature Range	-55 to 150	°C
$T_{OP}$	Storage Temperature Range	-40 to 125	°C

1. Above 14V the device is automatically in shut-down.

*Note: Absolute Maximum Ratings are those values beyond which damage to the device may occur. Functional operation under these conditions is not implied.*

**Table 3. Thermal data**

Symbol	Parameter	DPAK	PPAK	Unit
$R_{thJC}$	Thermal resistance junction-case	8	8	°C/W
$R_{thJA}$	Thermal resistance junction-ambient	100	100	°C/W

## 4 Electrical characteristics

**Table 4. Electrical characteristics of LD29080#15**

$I_O = 10\text{mA}$ , (*Note 4*)  $T_J = 25^\circ\text{C}$ ,  $V_I = 3.5\text{V}$ ,  $V_{INH} = 2\text{V}$ ,  $C_I = 330\text{nF}$ ,  $C_O = 10\mu\text{F}$ , unless otherwise specified)

Symbol	Parameter	Test Conditions	Min.	Typ.	Max.	Unit
$V_I$	Operating Input Voltage	$I_O = 10\text{mA}$ to $800\text{mA}$	2.5		13	V
$V_O$	Output Voltage	$I_O = 10\text{mA}$ to $800\text{mA}$ , $V_I = 3$ to $7\text{V}$ $T_J = -40$ to $125^\circ\text{C}$	1.485	1.5	1.515	V
			1.463		1.537	
$\Delta V_O$	Load Regulation	$I_O = 10\text{mA}$ to $800\text{mA}$		0.2	1.0	%
$\Delta V_O$	Line Regulation	$V_I = 3$ to $13\text{V}$		0.06	0.5	%
SVR	Supply Voltage Rejection	$f = 120\text{ Hz}$ , $V_I = 3.8 \pm 1\text{V}$ , $I_O = 400\text{mA}$ ( <i>Note 1</i> )	65	75		dB
$I_q$	Quiescent Current	$I_O = 10\text{mA}$ , $T_J = -40$ to $125^\circ\text{C}$		2	5	mA
		$I_O = 400\text{mA}$ , $T_J = -40$ to $125^\circ\text{C}$		8	20	
		$I_O = 800\text{mA}$ , $T_J = -40$ to $125^\circ\text{C}$		14	35	
		$V_I = 13\text{V}$ , $V_{INH} = \text{GND}$ , $T_J = -40$ to $125^\circ\text{C}$		130	180	$\mu\text{A}$
$I_{sc}$	Short Circuit Current	$R_L = 0$		1.2		A
$V_{IL}$	Control Input Logic Low	OFF MODE, $T_J = -40$ to $125^\circ\text{C}$			0.8	V
$V_{IH}$	Control Input Logic High	ON MODE, $T_J = -40$ to $125^\circ\text{C}$	2			V
$I_{INH}$	Control Input Current	$V_{INH} = 13\text{V}$ , $T_J = -40$ to $125^\circ\text{C}$		5	10	$\mu\text{A}$
eN	Output Noise Voltage	$B_P = 10\text{Hz}$ to $100\text{kHz}$ , $I_O = 100\text{mA}$		60		$\mu\text{V}_{\text{RMS}}$

Note: 1 Guaranteed by design.

2 Dropout voltage is defined as the input-to-output differential when the output voltage drops to 99% of its nominal value with  $V_O + 1\text{V}$  applied to  $V_I$ .

3 Reference Voltage is measured between output and GND pins, with ADJ PIN tied to  $V_O$ .

4 In order to avoid any output voltage rise within the whole operating temperature range, due to output leakage current, a minimum load current of  $2\text{mA}$  is required.

**Table 5. Electrical characteristics of LD29080#18**

$I_O = 10\text{mA}$ , (*Note 4*)  $T_J = 25^\circ\text{C}$ ,  $V_I = 3.5\text{V}$ ,  $V_{\text{INH}} = 2\text{V}$ ,  $C_I = 330\text{nF}$ ,  $C_O = 10\mu\text{F}$ , unless otherwise specified)

Symbol	Parameter	Test Conditions	Min.	Typ.	Max.	Unit
$V_I$	Operating Input Voltage	$I_O = 10\text{mA}$ to $800\text{mA}$	2.5		13	V
$V_O$	Output Voltage	$I_O = 10\text{mA}$ to $800\text{mA}$ , $V_I = 3$ to $7.3\text{V}$ $T_J = -40$ to $125^\circ\text{C}$	1.782	1.8	1.818	V
			1.755		1.845	
$\Delta V_O$	Load Regulation	$I_O = 10\text{mA}$ to $800\text{mA}$		0.2	1.0	%
$\Delta V_O$	Line Regulation	$V_I = 3$ to $13\text{V}$		0.06	0.5	%
SVR	Supply Voltage Rejection	$f = 120\text{ Hz}$ , $V_I = 3.8 \pm 1\text{V}$ , $I_O = 400\text{mA}$ ( <i>Note 1</i> )	62	72		dB
$V_{\text{DROPP}}$	Dropout Voltage	$I_O = 150\text{mA}$ , $T_J = -40$ to $125^\circ\text{C}$ ( <i>Note 2</i> )		0.1		V
		$I_O = 400\text{mA}$ , $T_J = -40$ to $125^\circ\text{C}$ ( <i>Note 2</i> )		0.2		
		$I_O = 800\text{mA}$ , $T_J = -40$ to $125^\circ\text{C}$ ( <i>Note 2</i> )		0.4	0.7	
$I_q$	Quiescent Current	$I_O = 10\text{mA}$ , $T_J = -40$ to $125^\circ\text{C}$		2	5	mA
		$I_O = 400\text{mA}$ , $T_J = -40$ to $125^\circ\text{C}$		8	20	
		$I_O = 800\text{mA}$ , $T_J = -40$ to $125^\circ\text{C}$		14	35	
		$V_I = 13\text{V}$ , $V_{\text{INH}} = \text{GND}$ , $T_J = -40$ to $125^\circ\text{C}$		130	180	$\mu\text{A}$
$I_{\text{sc}}$	Short Circuit Current	$R_L = 0$		1.2		A
$V_{\text{IL}}$	Control Input Logic Low	OFF MODE, $T_J = -40$ to $125^\circ\text{C}$			0.8	V
$V_{\text{IH}}$	Control Input Logic High	ON MODE, $T_J = -40$ to $125^\circ\text{C}$	2			V
$I_{\text{INH}}$	Control Input Current	$V_{\text{INH}} = 13\text{V}$ , $T_J = -40$ to $125^\circ\text{C}$		5	10	$\mu\text{A}$
eN	Output Noise Voltage	$B_P = 10\text{Hz}$ to $100\text{KHz}$ , $I_O = 100\text{mA}$		72		$\mu\text{V}_{\text{RMS}}$

Note: 1 Guaranteed by design.

2 Dropout voltage is defined as the input-to-output differential when the output voltage drops to 99% of its nominal value with  $V_O + 1\text{V}$  applied to  $V_I$ .

3 Reference Voltage is measured between output and GND pins, with ADJ PIN tied to  $V_O$ .

4 In order to avoid any output voltage rise within the whole operating temperature range, due to output leakage current, a minimum load current of  $2\text{mA}$  is required.

**Table 6. Electrical characteristics of LD29080#25**

$I_O = 10\text{mA}$ , (*Note 4*)  $T_J = 25^\circ\text{C}$ ,  $V_I = 4.5\text{V}$ ,  $V_{\text{INH}} = 2\text{V}$ ,  $C_I = 330\text{nF}$ ,  $C_O = 10\mu\text{F}$ , unless otherwise specified)

Symbol	Parameter	Test Conditions	Min.	Typ.	Max.	Unit
$V_I$	Operating Input Voltage	$I_O = 10\text{mA}$ to $800\text{mA}$			13	V
$V_O$	Output Voltage	$I_O = 10\text{mA}$ to $800\text{mA}$ , $V_I = 3.5$ to $8\text{V}$ $T_J = -40$ to $125^\circ\text{C}$	2.475	2.5	2.525	V
			2.438		2.562	
$\Delta V_O$	Load Regulation	$I_O = 10\text{mA}$ to $800\text{mA}$		0.2	1.0	%
$\Delta V_O$	Line Regulation	$V_I = 3.5$ to $13\text{V}$		0.06	0.5	%
SVR	Supply Voltage Rejection	$f = 120\text{ Hz}$ , $V_I = 4.5 \pm 1\text{V}$ , $I_O = 400\text{mA}$ ( <i>Note 1</i> )	55	70		dB
$V_{\text{DROPP}}$	Dropout Voltage	$I_O = 150\text{mA}$ , $T_J = -40$ to $125^\circ\text{C}$ ( <i>Note 2</i> )		0.1		V
		$I_O = 400\text{mA}$ , $T_J = -40$ to $125^\circ\text{C}$ ( <i>Note 2</i> )		0.2		
		$I_O = 800\text{mA}$ , $T_J = -40$ to $125^\circ\text{C}$ ( <i>Note 2</i> )		0.4	0.7	
$I_q$	Quiescent Current	$I_O = 10\text{mA}$ , $T_J = -40$ to $125^\circ\text{C}$		2	5	mA
		$I_O = 400\text{mA}$ , $T_J = -40$ to $125^\circ\text{C}$		8	20	
		$I_O = 800\text{mA}$ , $T_J = -40$ to $125^\circ\text{C}$		14	35	
		$V_I = 13\text{V}$ , $V_{\text{INH}} = \text{GND}$ , $T_J = -40$ to $125^\circ\text{C}$		130	180	$\mu\text{A}$
$I_{\text{sc}}$	Short Circuit Current	$R_L = 0$		1.2		A
$V_{\text{IL}}$	Control Input Logic Low	OFF MODE, $T_J = -40$ to $125^\circ\text{C}$			0.8	V
$V_{\text{IH}}$	Control Input Logic High	ON MODE, $T_J = -40$ to $125^\circ\text{C}$	2			V
$I_{\text{INH}}$	Control Input Current	$V_{\text{INH}} = 13\text{V}$ , $T_J = -40$ to $125^\circ\text{C}$		5	10	$\mu\text{A}$
eN	Output Noise Voltage	$B_P = 10\text{Hz}$ to $100\text{KHz}$ , $I_O = 100\text{mA}$		100		$\mu\text{V}_{\text{RMS}}$

Note: 1 Guaranteed by design.

2 Dropout voltage is defined as the input-to-output differential when the output voltage drops to 99% of its nominal value with  $V_O + 1\text{V}$  applied to  $V_I$ .

3 Reference Voltage is measured between output and GND pins, with ADJ PIN tied to  $V_O$ .

4 In order to avoid any output voltage rise within the whole operating temperature range, due to output leakage current, a minimum load current of  $2\text{mA}$  is required.



**Table 7. Electrical characteristics of LD29080#33**

$I_O = 10\text{mA}$ , (*Note 4*)  $T_J = 25^\circ\text{C}$ ,  $V_I = 5.3\text{V}$ ,  $V_{\text{INH}} = 2\text{V}$ ,  $C_I = 330\text{nF}$ ,  $C_O = 10\mu\text{F}$ , unless otherwise specified)

Symbol	Parameter	Test Conditions	Min.	Typ.	Max.	Unit
$V_I$	Operating Input Voltage	$I_O = 10\text{mA}$ to $800\text{mA}$			13	V
$V_O$	Output Voltage	$I_O = 10\text{mA}$ to $800\text{mA}$ , $V_I = 4.3$ to $8.8\text{V}$ $T_J = -40$ to $125^\circ\text{C}$	3.267	3.3	3.333	V
			3.218		3.382	
$\Delta V_O$	Load Regulation	$I_O = 10\text{mA}$ to $800\text{mA}$		0.2	1.0	%
$\Delta V_O$	Line Regulation	$V_I = 4.3$ to $13\text{V}$		0.06	0.5	%
SVR	Supply Voltage Rejection	$f = 120\text{ Hz}$ , $V_I = 5.3 \pm 1\text{V}$ , $I_O = 400\text{mA}$ ( <i>Note 1</i> )	52	67		dB
$V_{\text{DROPP}}$	Dropout Voltage	$I_O = 150\text{mA}$ , $T_J = -40$ to $125^\circ\text{C}$ ( <i>Note 2</i> )		0.1		V
		$I_O = 400\text{mA}$ , $T_J = -40$ to $125^\circ\text{C}$ ( <i>Note 2</i> )		0.2		
		$I_O = 800\text{mA}$ , $T_J = -40$ to $125^\circ\text{C}$ ( <i>Note 2</i> )		0.4	0.7	
$I_q$	Quiescent Current	$I_O = 10\text{mA}$ , $T_J = -40$ to $125^\circ\text{C}$		2	5	mA
		$I_O = 400\text{mA}$ , $T_J = -40$ to $125^\circ\text{C}$		8	20	
		$I_O = 800\text{mA}$ , $T_J = -40$ to $125^\circ\text{C}$		14	35	
		$V_I = 13\text{V}$ , $V_{\text{INH}} = \text{GND}$ , $T_J = -40$ to $125^\circ\text{C}$		130	180	$\mu\text{A}$
$I_{\text{sc}}$	Short Circuit Current	$R_L = 0$		1.2		A
$V_{\text{IL}}$	Control Input Logic Low	OFF MODE, $T_J = -40$ to $125^\circ\text{C}$			0.8	V
$V_{\text{IH}}$	Control Input Logic High	ON MODE, $T_J = -40$ to $125^\circ\text{C}$	2			V
$I_{\text{INH}}$	Control Input Current	$V_{\text{INH}} = 13\text{V}$ , $T_J = -40$ to $125^\circ\text{C}$		5	10	$\mu\text{A}$
eN	Output Noise Voltage	$B_P = 10\text{Hz}$ to $100\text{KHz}$ , $I_O = 100\text{mA}$		132		$\mu\text{V}_{\text{RMS}}$

Note: 1 Guaranteed by design.

2 Dropout voltage is defined as the input-to-output differential when the output voltage drops to 99% of its nominal value with  $V_O + 1\text{V}$  applied to  $V_I$ .

3 Reference Voltage is measured between output and GND pins, with ADJ PIN tied to  $V_O$ .

4 In order to avoid any output voltage rise within the whole operating temperature range, due to output leakage current, a minimum load current of  $2\text{mA}$  is required.

**Table 8. Electrical characteristics of LD29080#50**

$I_O = 10\text{mA}$ , (*Note 4*)  $T_J = 25^\circ\text{C}$ ,  $V_I = 7\text{V}$ ,  $V_{\text{INH}} = 2\text{V}$ ,  $C_I = 330\text{nF}$ ,  $C_O = 10\mu\text{F}$ , unless otherwise specified)

Symbol	Parameter	Test Conditions	Min.	Typ.	Max.	Unit
$V_I$	Operating Input Voltage	$I_O = 10\text{mA}$ to $800\text{mA}$			13	V
$V_O$	Output Voltage	$I_O = 10\text{mA}$ to $800\text{mA}$ , $V_I = 6$ to $10.5\text{V}$ $T_J = -40$ to $125^\circ\text{C}$	4.95 4.875	5	5.05 5.125	V
$\Delta V_O$	Load Regulation	$I_O = 10\text{mA}$ to $800\text{mA}$		0.2	1.0	%
$\Delta V_O$	Line Regulation	$V_I = 6$ to $13\text{V}$		0.06	0.5	%
SVR	Supply Voltage Rejection	$f = 120\text{ Hz}$ , $V_I = 7 \pm 1\text{V}$ , $I_O = 400\text{mA}$ ( <i>Note 1</i> )	49	64		dB
$V_{\text{DROPP}}$	Dropout Voltage	$I_O = 150\text{mA}$ , $T_J = -40$ to $125^\circ\text{C}$ ( <i>Note 2</i> )		0.1		V
		$I_O = 400\text{mA}$ , $T_J = -40$ to $125^\circ\text{C}$ ( <i>Note 2</i> )		0.2		
		$I_O = 800\text{mA}$ , $T_J = -40$ to $125^\circ\text{C}$ ( <i>Note 2</i> )		0.4	0.7	
$I_q$	Quiescent Current	$I_O = 10\text{mA}$ , $T_J = -40$ to $125^\circ\text{C}$		2	5	mA
		$I_O = 400\text{mA}$ , $T_J = -40$ to $125^\circ\text{C}$		8	20	
		$I_O = 800\text{mA}$ , $T_J = -40$ to $125^\circ\text{C}$		14	35	
		$V_I = 13\text{V}$ , $V_{\text{INH}} = \text{GND}$ , $T_J = -40$ to $125^\circ\text{C}$		130	180	$\mu\text{A}$
$I_{\text{sc}}$	Short Circuit Current	$R_L = 0$		1.2		A
$V_{\text{IL}}$	Control Input Logic Low	OFF MODE, $T_J = -40$ to $125^\circ\text{C}$			0.8	V
$V_{\text{IH}}$	Control Input Logic High	ON MODE, $T_J = -40$ to $125^\circ\text{C}$	2			V
$I_{\text{INH}}$	Control Input Current	$V_{\text{INH}} = 13\text{V}$ , $T_J = -40$ to $125^\circ\text{C}$		5	10	$\mu\text{A}$
eN	Output Noise Voltage	$B_P = 10\text{Hz}$ to $100\text{KHz}$ , $I_O = 100\text{mA}$		320		$\mu\text{V}_{\text{RMS}}$

Note: 1 Guaranteed by design.

2 Dropout voltage is defined as the input-to-output differential when the output voltage drops to 99% of its nominal value with  $V_O + 1\text{V}$  applied to  $V_I$ .

3 Reference Voltage is measured between output and GND pins, with ADJ PIN tied to  $V_O$ .

4 In order to avoid any output voltage rise within the whole operating temperature range, due to output leakage current, a minimum load current of  $2\text{mA}$  is required.

**Table 9. Electrical characteristics of LD29080#80**

$I_O = 10\text{mA}$ , (*Note 4*)  $T_J = 25^\circ\text{C}$ ,  $V_I = 10\text{V}$ ,  $V_{\text{INH}} = 2\text{V}$ ,  $C_I = 330\text{nF}$ ,  $C_O = 10\mu\text{F}$ , unless otherwise specified)

Symbol	Parameter	Test Conditions	Min.	Typ.	Max.	Unit
$V_I$	Operating Input Voltage	$I_O = 10\text{mA}$ to $800\text{mA}$			13	V
$V_O$	Output Voltage	$I_O = 10\text{mA}$ to $800\text{mA}$ , $V_I = 9$ to $13\text{V}$ $T_J = -40$ to $125^\circ\text{C}$	7.92	8	8.08	V
			7.80		8.20	
$\Delta V_O$	Load Regulation	$I_O = 10\text{mA}$ to $800\text{mA}$		0.2	1.0	%
$\Delta V_O$	Line Regulation	$V_I = 9$ to $13\text{V}$		0.06	0.5	%
SVR	Supply Voltage Rejection	$f = 120\text{ Hz}$ , $V_I = 9 \pm 1\text{V}$ , $I_O = 400\text{mA}$ ( <i>Note 1</i> )	45	59		dB
$V_{\text{DROPP}}$	Dropout Voltage	$I_O = 150\text{mA}$ , $T_J = -40$ to $125^\circ\text{C}$ ( <i>Note 2</i> )		0.1		V
		$I_O = 400\text{mA}$ , $T_J = -40$ to $125^\circ\text{C}$ ( <i>Note 2</i> )		0.2		
		$I_O = 800\text{mA}$ , $T_J = -40$ to $125^\circ\text{C}$ ( <i>Note 2</i> )		0.4	0.7	
$I_q$	Quiescent Current	$I_O = 10\text{mA}$ , $T_J = -40$ to $125^\circ\text{C}$		2	5	mA
		$I_O = 400\text{mA}$ , $T_J = -40$ to $125^\circ\text{C}$		8	20	
		$I_O = 800\text{mA}$ , $T_J = -40$ to $125^\circ\text{C}$		14	35	
		$V_I = 13\text{V}$ , $V_{\text{INH}} = \text{GND}$ , $T_J = -40$ to $125^\circ\text{C}$		130	180	$\mu\text{A}$
$I_{\text{sc}}$	Short Circuit Current	$R_L = 0$		1.2		A
$V_{\text{IL}}$	Control Input Logic Low	OFF MODE, $T_J = -40$ to $125^\circ\text{C}$			0.8	V
$V_{\text{IH}}$	Control Input Logic High	ON MODE, $T_J = -40$ to $125^\circ\text{C}$	2			V
$I_{\text{INH}}$	Control Input Current	$V_{\text{INH}} = 13\text{V}$ , $T_J = -40$ to $125^\circ\text{C}$		5	10	$\mu\text{A}$
eN	Output Noise Voltage	$B_P = 10\text{Hz}$ to $100\text{KHz}$ , $I_O = 100\text{mA}$		320		$\mu\text{V}_{\text{RMS}}$

Note: 1 Guaranteed by design.

2 Dropout voltage is defined as the input-to-output differential when the output voltage drops to 99% of its nominal value with  $V_O + 1\text{V}$  applied to  $V_I$ .

3 Reference Voltage is measured between output and GND pins, with ADJ PIN tied to  $V_O$ .

4 In order to avoid any output voltage rise within the whole operating temperature range, due to output leakage current, a minimum load current of  $2\text{mA}$  is required.

**Table 10. Electrical characteristics of LD29080#ADJ**

$I_O = 10\text{mA}$ , (*Note 4*)  $T_J = 25^\circ\text{C}$ ,  $V_I = 10\text{V}$ ,  $V_{\text{INH}} = 2\text{V}$ ,  $C_I = 330\text{nF}$ ,  $C_O = 10\mu\text{F}$ , unless otherwise specified)

Symbol	Parameter	Test Conditions	Min.	Typ.	Max.	Unit
$V_I$	Operating Input Voltage	$I_O = 10\text{mA}$ to $800\text{mA}$	2.5		13	V
$\Delta V_O$	Load Regulation	$I_O = 10\text{mA}$ to $800\text{mA}$		0.2	1.0	%
$\Delta V_O$	Line Regulation	$V_I = 2.5$ to $13\text{V}$ , $I_O = 10\text{mA}$		0.06	0.5	%
$V_{\text{REF}}$	Reference voltage	$I_O = 10\text{mA}$ to $800\text{mA}$ , $V_I = 2.5$ to $6.73\text{V}$ $T_J = -40$ to $125^\circ\text{C}$ ( <i>Note 3</i> )	1.2177 1.1993	1.23	1.2423 1.2607	V
SVR	Supply Voltage Rejection	$f = 120\text{ Hz}$ , $V_I = 3.23 \pm 1\text{V}$ , $I_O = 400\text{mA}$ ( <i>Note 1</i> )	45	75		dB
$I_q$	Quiescent Current	$I_O = 10\text{mA}$ , $T_J = -40$ to $125^\circ\text{C}$		2	5	mA
		$I_O = 400\text{mA}$ , $T_J = -40$ to $125^\circ\text{C}$		8	20	
		$I_O = 800\text{mA}$ , $T_J = -40$ to $125^\circ\text{C}$		14	35	
		$V_I = 13\text{V}$ , $V_{\text{INH}} = \text{GND}$ , $T_J = -40$ to $125^\circ\text{C}$		130	180	$\mu\text{A}$
$I_{\text{ADJ}}$	Adjust Pin Current	$T_J = -40$ to $125^\circ\text{C}$			1	$\mu\text{A}$
$I_{\text{sc}}$	Short Circuit Current	$R_L = 0$		1.2		A
$V_{\text{IL}}$	Control Input Logic Low	OFF MODE, $T_J = -40$ to $125^\circ\text{C}$			0.8	V
$V_{\text{IH}}$	Control Input Logic High	ON MODE, $T_J = -40$ to $125^\circ\text{C}$	2			V
$I_{\text{INH}}$	Control Input Current	$V_{\text{INH}} = 13\text{V}$ , $T_J = -40$ to $125^\circ\text{C}$		5	10	$\mu\text{A}$
eN	Output Noise Voltage	$B_P = 10\text{Hz}$ to $100\text{KHz}$ , $I_O = 100\text{mA}$		50		$\mu\text{V}_{\text{RMS}}$

Note: 1 Guaranteed by design.

2 Dropout voltage is defined as the input-to-output differential when the output voltage drops to 99% of its nominal value with  $V_O + 1\text{V}$  applied to  $V_I$ .

3 Reference Voltage is measured between output and GND pins, with ADJ PIN tied to  $V_O$ .

4 In order to avoid any output voltage rise within the whole operating temperature range, due to output leakage current, a minimum load current of  $2\text{mA}$  is required.

# 5 Typical characteristics

**Figure 5. Output voltage vs temperature**

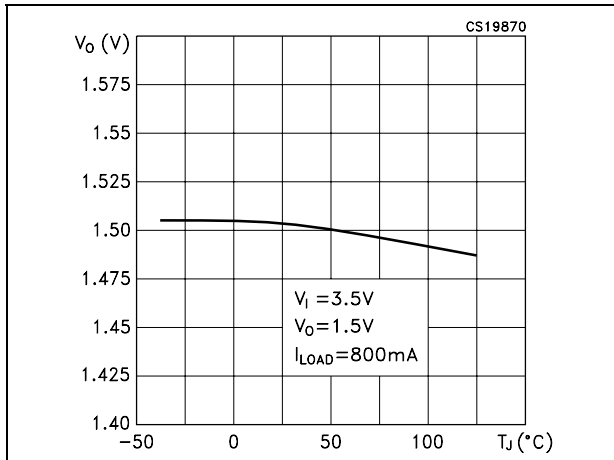

**Figure 6. Reference voltage vs temperature**

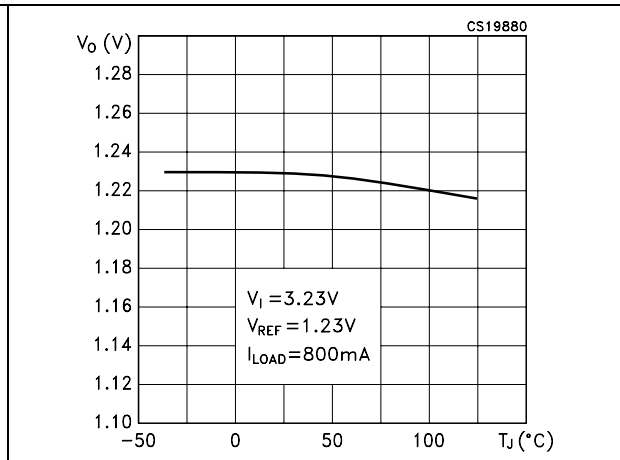

**Figure 7. Dropout voltage vs temperature**

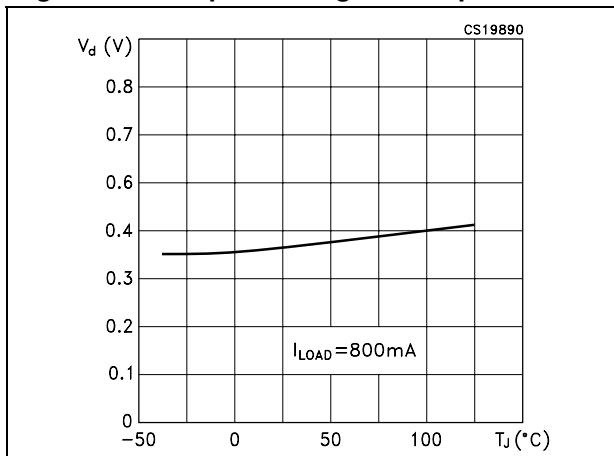

**Figure 8. Dropout voltage vs output current**

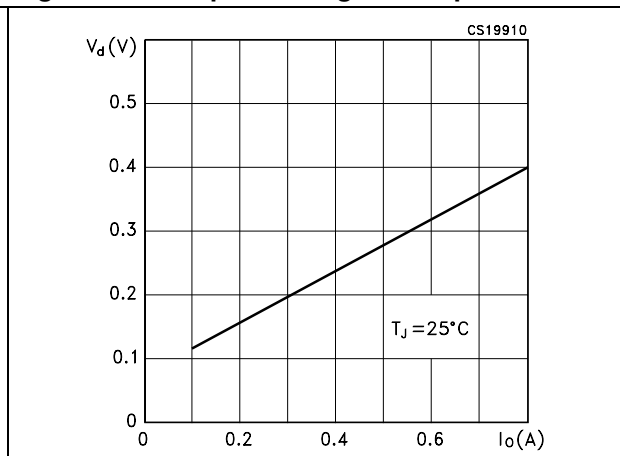

**Figure 9. Quiescent current vs output current** **Figure 10. Quiescent current vs temperature**

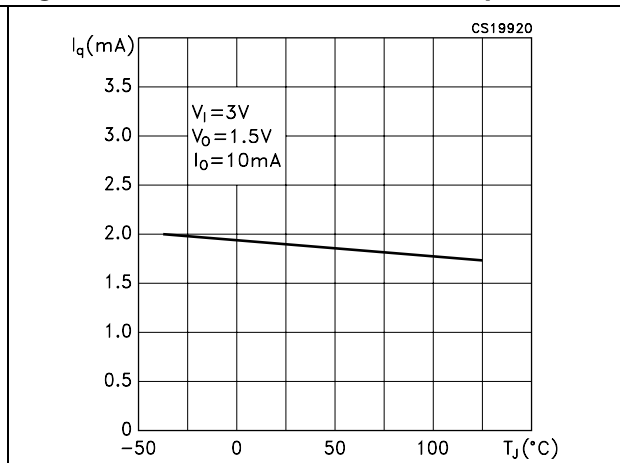
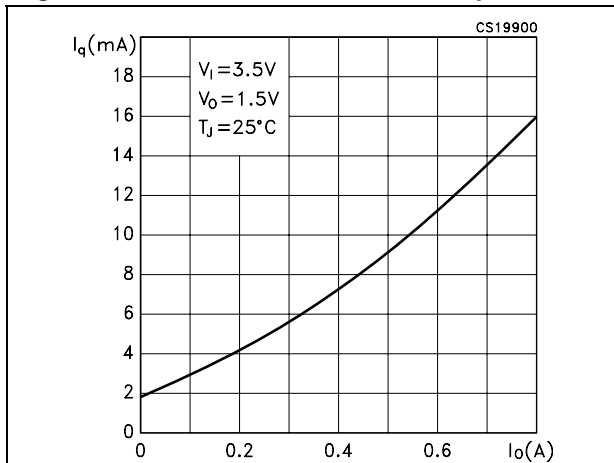

Figure 11. Quiescent current vs supply voltage

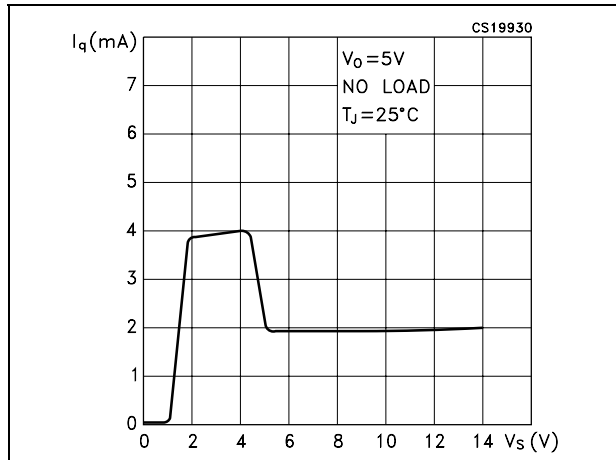

Figure 12. Quiescent current vs temperature

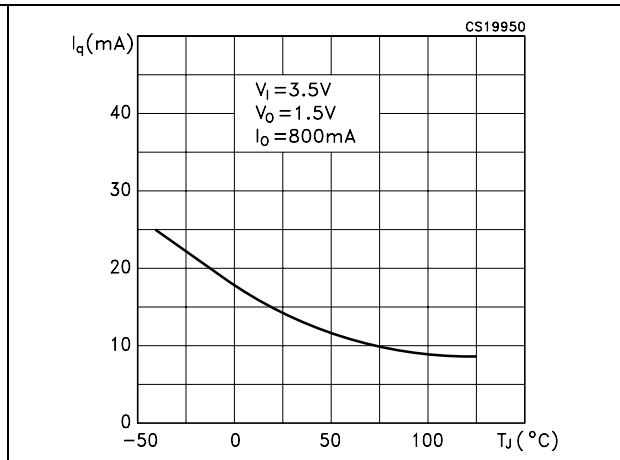

Figure 13. Short circuit current vs temperature Figure 14. Adjust pin current vs temperature

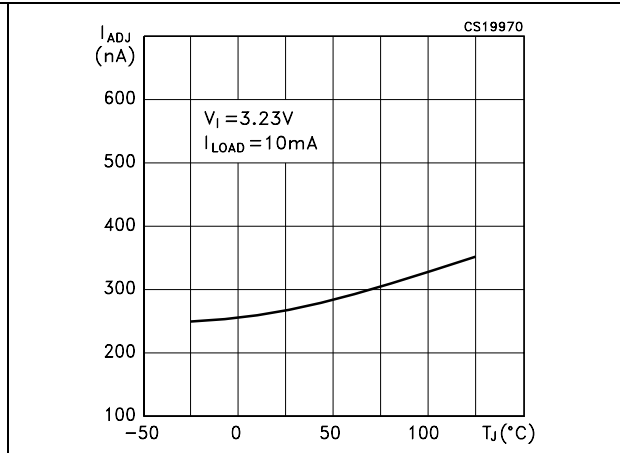
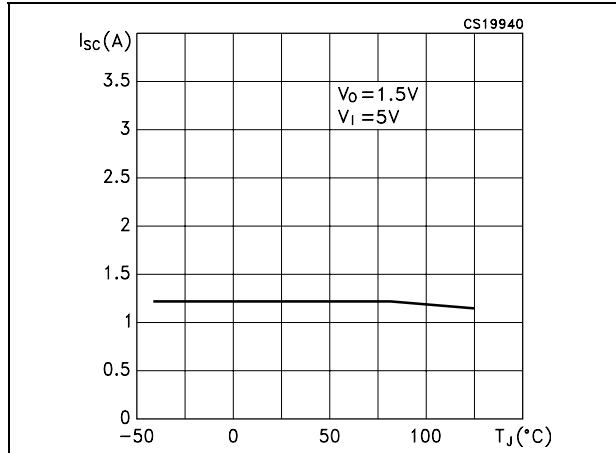

Figure 15. Supply voltage rejection vs temperature

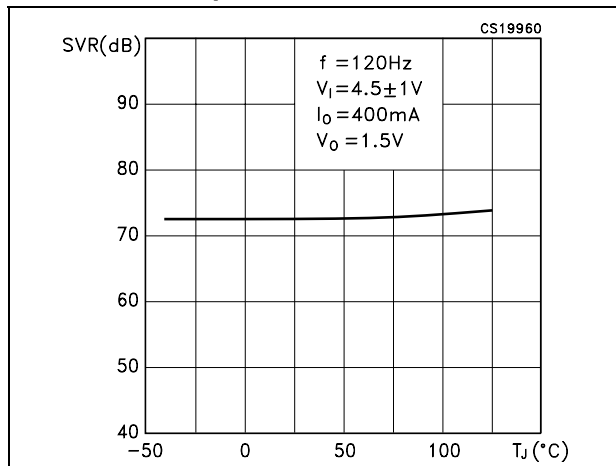

Figure 16. Output voltage vs input voltage

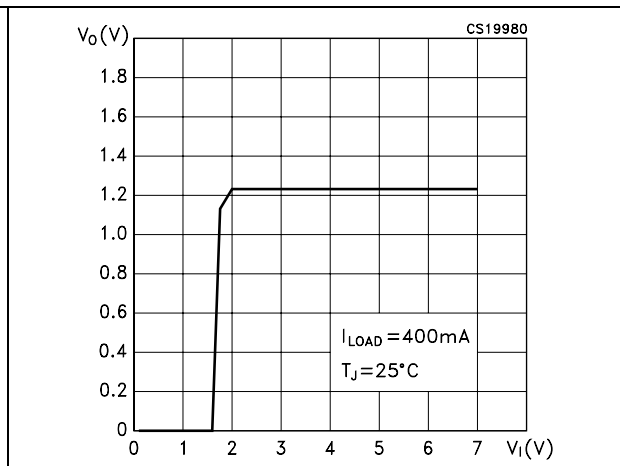

Figure 17. Stability vs  $C_O$

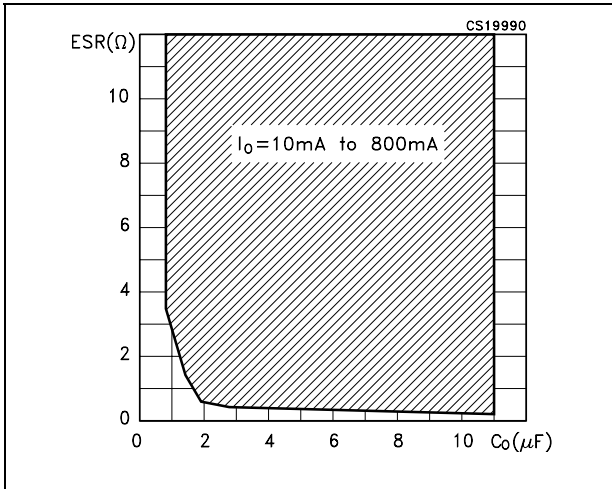

Figure 18. Line transient

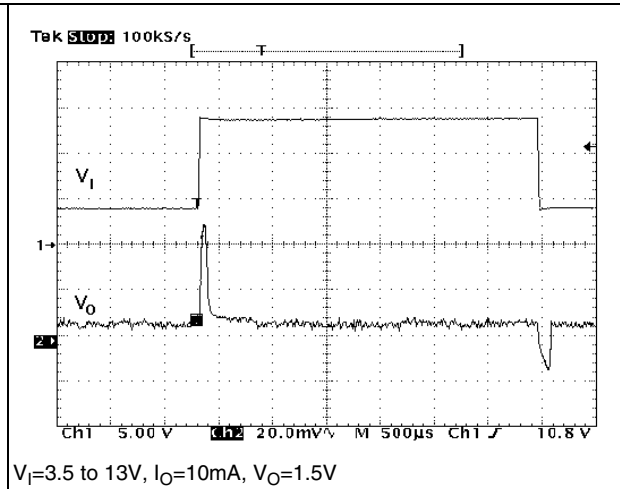
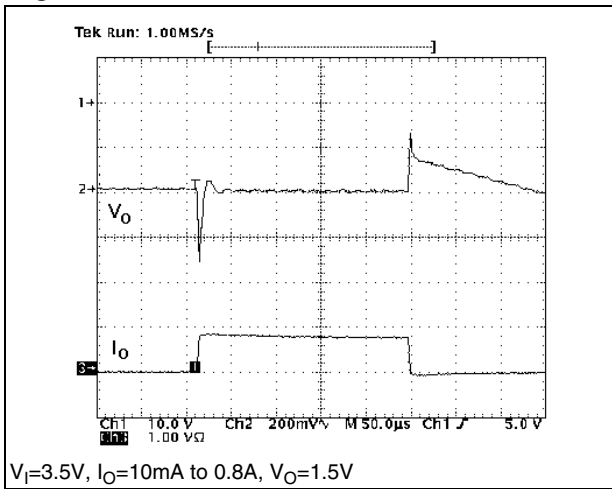

Figure 19. Load transient



## 6 Package mechanical data

In order to meet environmental requirements, ST offers these devices in ECOPACK<sup>®</sup> packages. These packages have a Lead-free second level interconnect. The category of second Level Interconnect is marked on the package and on the inner box label, in compliance with JEDEC Standard JESD97. The maximum ratings related to soldering conditions are also marked on the inner box label. ECOPACK is an ST trademark. ECOPACK specifications are available at: [www.st.com](http://www.st.com).



**PPAK MECHANICAL DATA**

DIM.	mm.			inch		
	MIN.	TYP	MAX.	MIN.	TYP.	MAX.
A	2.2		2.4	0.086		0.094
A1	0.9		1.1	0.035		0.043
A2	0.03		0.23	0.001		0.009
B	0.4		0.6	0.015		0.023
B2	5.2		5.4	0.204		0.212
C	0.45		0.6	0.017		0.023
C2	0.48		0.6	0.019		0.023
D	6		6.2	0.236		0.244
D1		5.1			0.201	
E	6.4		6.6	0.252		0.260
E1		4.7			0.185	
e		1.27			0.050	
G	4.9		5.25	0.193		0.206
G1	2.38		2.7	0.093		0.106
H	9.35		10.1	0.368		0.397
L2		0.8	1		0.031	0.039
L4	0.6		1	0.023		0.039
L5	1			0.039		
L6		2.8			0.110	

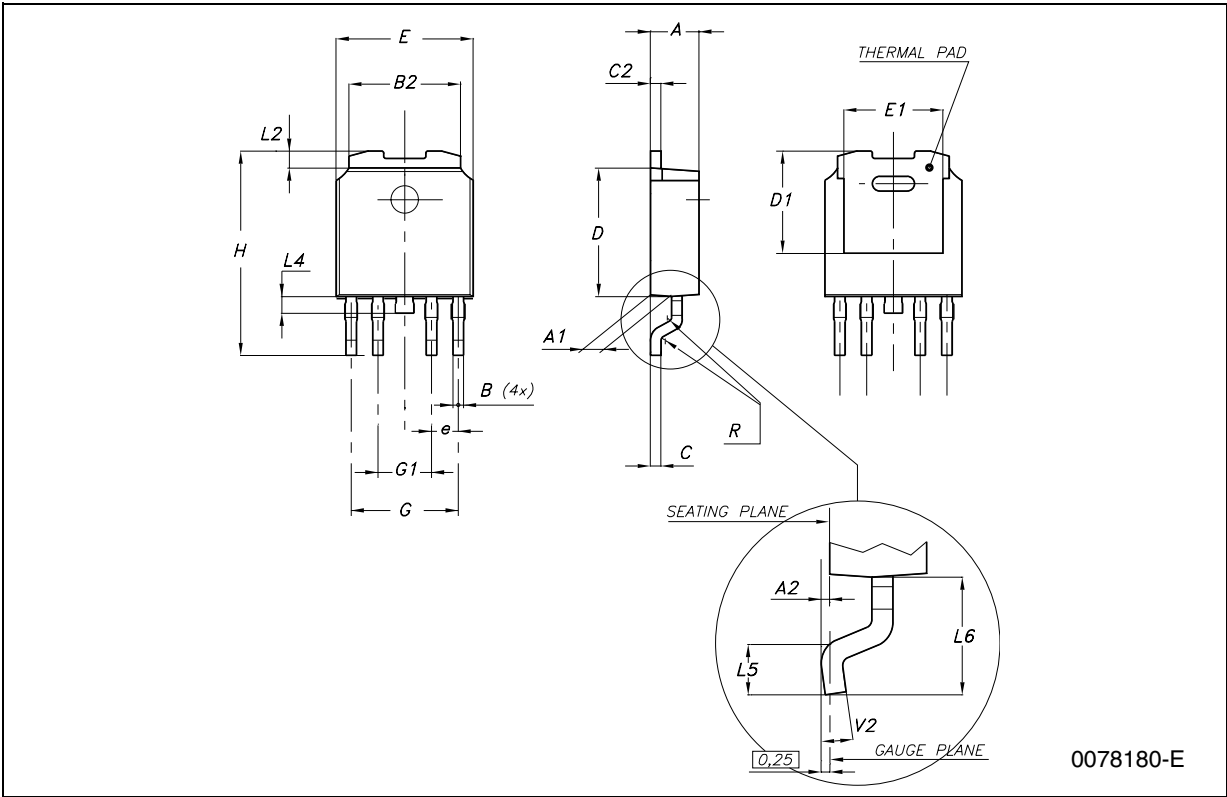

0078180-E



### DPAK MECHANICAL DATA

DIM.	mm.			inch		
	MIN.	TYP	MAX.	MIN.	TYP.	MAX.
A	2.2		2.4	0.086		0.094
A1	0.9		1.1	0.035		0.043
A2	0.03		0.23	0.001		0.009
B	0.64		0.9	0.025		0.035
b4	5.2		5.4	0.204		0.212
C	0.45		0.6	0.017		0.023
C2	0.48		0.6	0.019		0.023
D	6		6.2	0.236		0.244
D1		5.1			0.200	
E	6.4		6.6	0.252		0.260
E1		4.7			0.185	
e		2.28			0.090	
e1	4.4		4.6	0.173		0.181
H	9.35		10.1	0.368		0.397
L	1			0.039		
(L1)		2.8			0.110	
L2		0.8			0.031	
L4	0.6		1	0.023		0.039
R		0.2			0.008	
V2	0°		8°	0°		8°

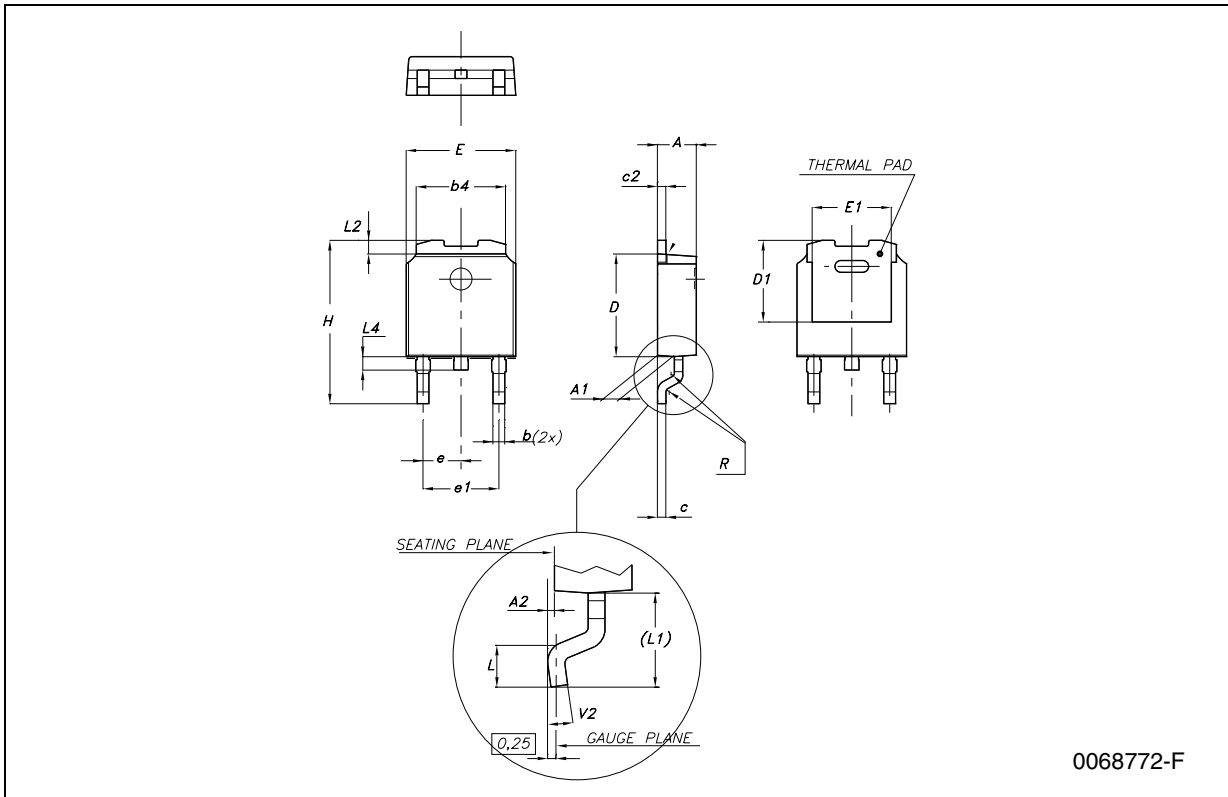

0068772-F

**Tape & Reel DPAK-PPAK MECHANICAL DATA**

DIM.	mm.			inch		
	MIN.	TYP	MAX.	MIN.	TYP.	MAX.
A			330			12.992
C	12.8	13.0	13.2	0.504	0.512	0.519
D	20.2			0.795		
N	60			2.362		
T			22.4			0.882
Ao	6.80	6.90	7.00	0.268	0.272	0.276
Bo	10.40	10.50	10.60	0.409	0.413	0.417
Ko	2.55	2.65	2.75	0.100	0.104	0.105
Po	3.9	4.0	4.1	0.153	0.157	0.161
P	7.9	8.0	8.1	0.311	0.315	0.319

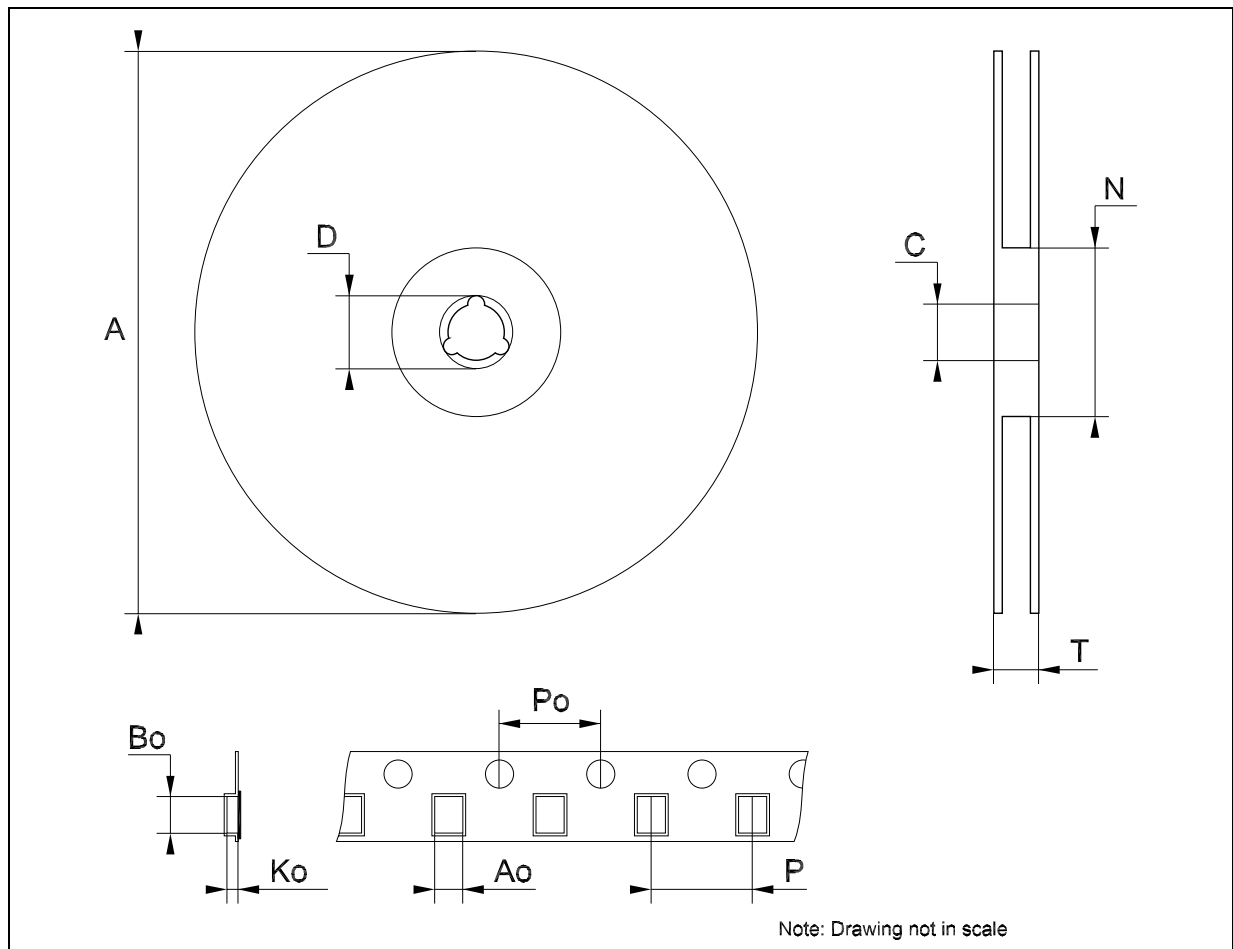

## 7 Revision history

**Table 11. Revision history**

Date	Revision	Changes
15-Oct-2004	1	First Release.
20-Oct-2005	2	Order codes has been updated.
14-May-2007	3	Order codes has been updated.

**Please Read Carefully:**

Information in this document is provided solely in connection with ST products. STMicroelectronics NV and its subsidiaries ("ST") reserve the right to make changes, corrections, modifications or improvements, to this document, and the products and services described herein at any time, without notice.

All ST products are sold pursuant to ST's terms and conditions of sale.

Purchasers are solely responsible for the choice, selection and use of the ST products and services described herein, and ST assumes no liability whatsoever relating to the choice, selection or use of the ST products and services described herein.

No license, express or implied, by estoppel or otherwise, to any intellectual property rights is granted under this document. If any part of this document refers to any third party products or services it shall not be deemed a license grant by ST for the use of such third party products or services, or any intellectual property contained therein or considered as a warranty covering the use in any manner whatsoever of such third party products or services or any intellectual property contained therein.

**UNLESS OTHERWISE SET FORTH IN ST'S TERMS AND CONDITIONS OF SALE ST DISCLAIMS ANY EXPRESS OR IMPLIED WARRANTY WITH RESPECT TO THE USE AND/OR SALE OF ST PRODUCTS INCLUDING WITHOUT LIMITATION IMPLIED WARRANTIES OF MERCHANTABILITY, FITNESS FOR A PARTICULAR PURPOSE (AND THEIR EQUIVALENTS UNDER THE LAWS OF ANY JURISDICTION), OR INFRINGEMENT OF ANY PATENT, COPYRIGHT OR OTHER INTELLECTUAL PROPERTY RIGHT.**

**UNLESS EXPRESSLY APPROVED IN WRITING BY AN AUTHORIZED ST REPRESENTATIVE, ST PRODUCTS ARE NOT RECOMMENDED, AUTHORIZED OR WARRANTED FOR USE IN MILITARY, AIR CRAFT, SPACE, LIFE SAVING, OR LIFE SUSTAINING APPLICATIONS, NOR IN PRODUCTS OR SYSTEMS WHERE FAILURE OR MALFUNCTION MAY RESULT IN PERSONAL INJURY, DEATH, OR SEVERE PROPERTY OR ENVIRONMENTAL DAMAGE. ST PRODUCTS WHICH ARE NOT SPECIFIED AS "AUTOMOTIVE GRADE" MAY ONLY BE USED IN AUTOMOTIVE APPLICATIONS AT USER'S OWN RISK.**

Resale of ST products with provisions different from the statements and/or technical features set forth in this document shall immediately void any warranty granted by ST for the ST product or service described herein and shall not create or extend in any manner whatsoever, any liability of ST.

ST and the ST logo are trademarks or registered trademarks of ST in various countries.

Information in this document supersedes and replaces all information previously supplied.

The ST logo is a registered trademark of STMicroelectronics. All other names are the property of their respective owners.

© 2007 STMicroelectronics - All rights reserved

STMicroelectronics group of companies

Australia - Belgium - Brazil - Canada - China - Czech Republic - Finland - France - Germany - Hong Kong - India - Israel - Italy - Japan - Malaysia - Malta - Morocco - Singapore - Spain - Sweden - Switzerland - United Kingdom - United States of America

[www.st.com](http://www.st.com)