



LCP3121

Application Specific Discretes
A.S.D.™

OVERVOLTAGE AND OVERCURRENT PROTECTION FOR TELECOM LINE

FEATURES AND BENEFITS

- UNIDIRECTIONAL OVERVOLTAGE SUPPRESSOR PROGRAMMABLE BY VOLTAGE AND CURRENT:
- PROGRAMMABLE BREAKDOWN VOLTAGE UP TO 100 V.
- PROGRAMMABLE CURRENT LIMITATION FROM 120 mA TO 600 mA.
- MULTI-LINE PROTECTION MODE : ONE DEVICE CAN PROTECT SEVERAL LINES.
- HIGH SURGE CURRENT CAPABILITY :
 $I_{PP} = 100A$ for 10/1000 μs .

DESCRIPTION

Dedicated to the protection of sensitive telecom equipment, the LCP3121 provides protection which can be programmed by both voltage and current.

The breakdown voltage can be easily programmed by using an external zener diode.

The protection function programmed by the current is achieved with the use of a resistor between the gate and the cathode. The value of the resistor will determine the level of the desired current before the triggering of the device.

A multiple protection mode is also performed when using several diodes providing each line interface with an optimized protection level.

If desired, a bidirectional protection function can be achieved by the use of two LCP3121.

COMPLIES WITH THE FOLLOWING STANDARDS :

CCITT K20 :	10/700 μs	6kV
	5/310 μs	150A
VDE 0433 :	10/700 μs	2kV
	5/310 μs	50A
VDE 0878 :	1.2/50 μs	1.5kV
	1/20 μs	40A
FCC part 68 :	2/10 μs	2.5kV
	2/10 μs	200A (*)
BELLCORE TR-NWT-001089 :	2/10 μs	2.5kV
	2/10 μs	200A (*)
BELLCORE TR-NWT-000974 :	10/1000 μs	1kV
	10/1000 μs	100A

(*) with series resistors or PTC.

TM: ASD is trademarks of STMicroelectronics.

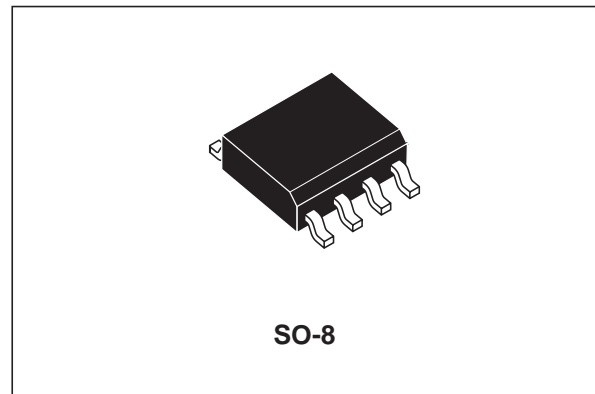

PIN-OUT CONFIGURATION

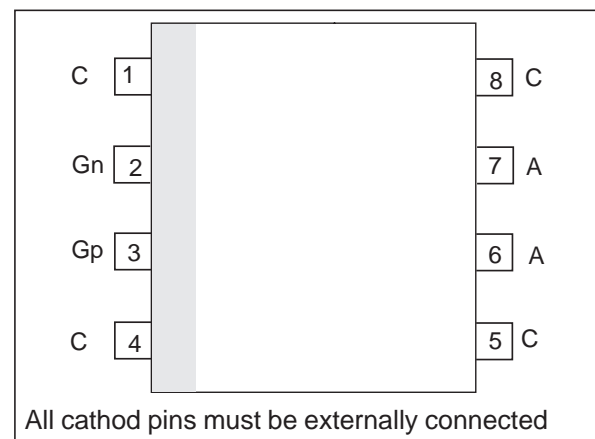

FUNCTIONAL DIAGRAM

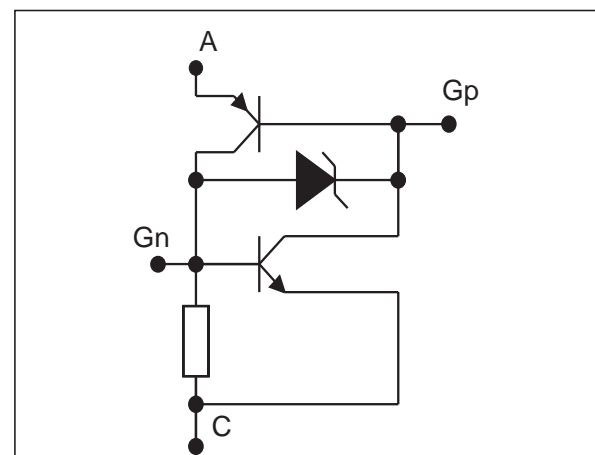

LCP3121

ABSOLUTE MAXIMUM RATINGS ($T_{amb} = 25^{\circ}\text{C}$)

Symbol	Parameter	Value	Unit
I_{PP}	Peak pulse current (see note 1)	10/1000 μs	A
I_{TSM}	Non repetitive surge peak on-state current (F = 50 Hz)	$t_p = 10\text{ms}$ $t = 1\text{s}$	A
V_{AC} V_{GA}	Maximum voltage between A and C Maximum voltage between G (Gn or Gp) and A	100 80	V
T_{stg} T_j	Storage temperature range Maximum junction temperature	- 40 to + 150 150	$^{\circ}\text{C}$
T_L	Maximum lead temperature for soldering during 10s	260	$^{\circ}\text{C}$

Note 1 : Pulse waveform :

10/1000 μs $t_r=10\mu\text{s}$ $t_p=1000\mu\text{s}$

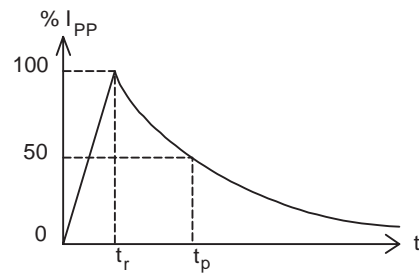

THERMAL RESISTANCE

Symbol	Parameter	Value	Unit
$R_{th(j-a)}$	Junction to ambient	170	$^{\circ}\text{C/W}$

ELECTRICAL CHARACTERISTICS ($T_{amb} = 25^{\circ}\text{C}$)

Symbol	Parameter
V_{RM}	Stand-off voltage
V_{BR}	Breakdown voltage
V_{BO}	Breakover voltage
I_H	Holding current
I_{BO}	Breakover current
I_{RM}	Leakage current at V_{RM}
I_R	Leakage current at V_R
I_{PP}	Peak pulse current
V_R	Continuous reverse voltage
C_{off}	Off-state capacitance
V_G	Gate voltage
I_{GP}	Gp triggering current
I_{GN}	Gn triggering current

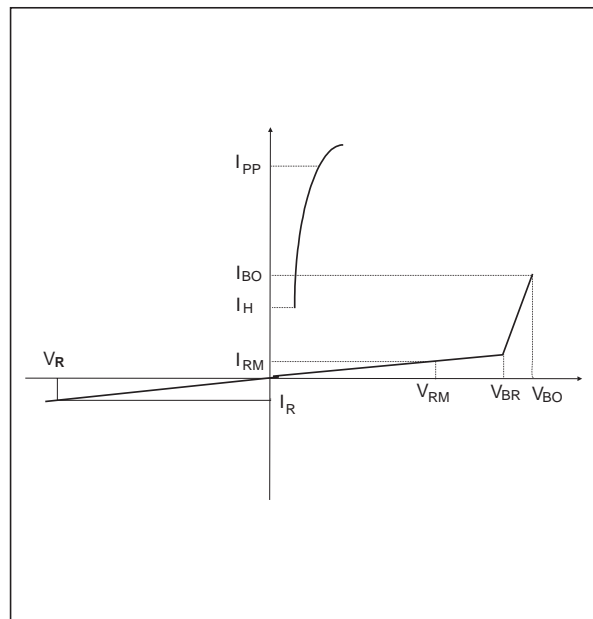

1 - OPERATION WITHOUT GATE ($T_{amb} = 25\text{ °C}$)

Symbol	Test conditions	Min.	Max.	Unit
I_{RM}	$V_{RM} = 60V$ $V_{RM} = 90V$		5 8	μA
I_R	at $V_R = 180V$		50	μA
V_{BR}	at 1mA	100		V
I_{BO}		80	500	mA
V_{BO}	Measured at 50Hz		180	V
I_H	See the functional test circuit	100		mA

2 - OPERATION WITH GATE ($T_{amb} = 25\text{ °C}$)

Symbol	Test conditions	Min.	Max.	Unit
V_G (note1)	$I_{GATE} = 200mA$ (for either G_n or G_p)	0.6	1.8	V
I_{GP}	$V_{Anode-cathode} = 60V$		180	mA
I_{GN}	$V_{Anode-cathode} = 60V$	80	200	mA

Note 1 : $V_G = V_{GN}$, measured between G_n and cathode
 $V_G = V_{GP}$, measured between G_p and anode

FUNCTIONAL HOLDING CURRENT (I_H) TEST CIRCUIT : GO-NO GO TEST

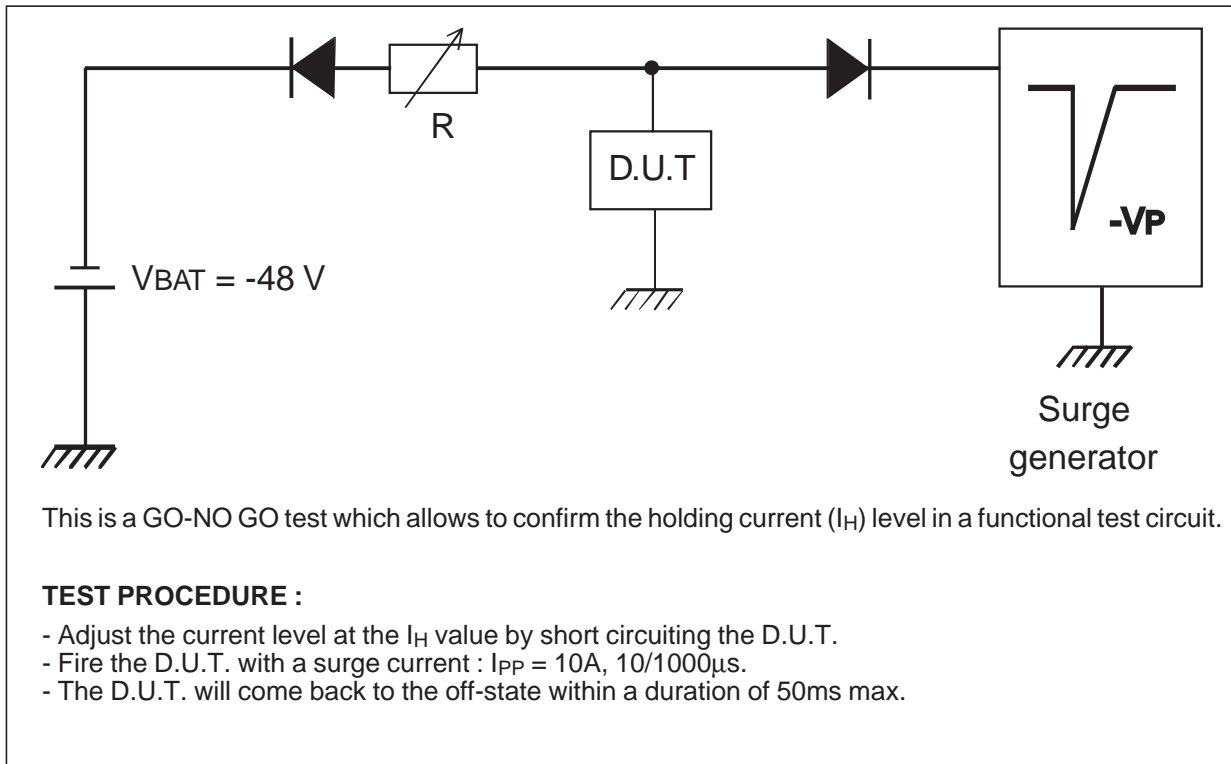

Fig. 1: Maximum non repetitive surge peak-on-state current versus overload duration.

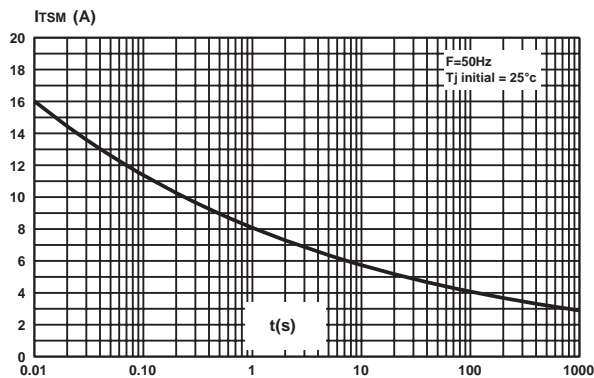
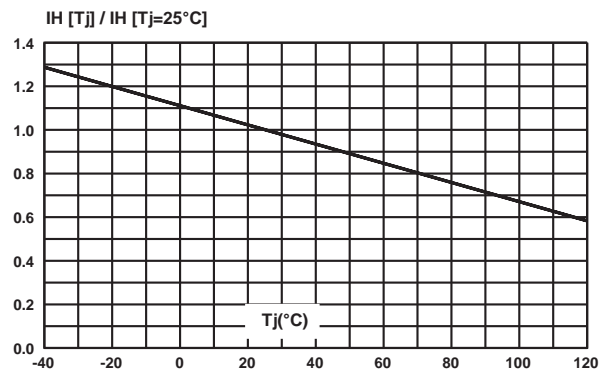
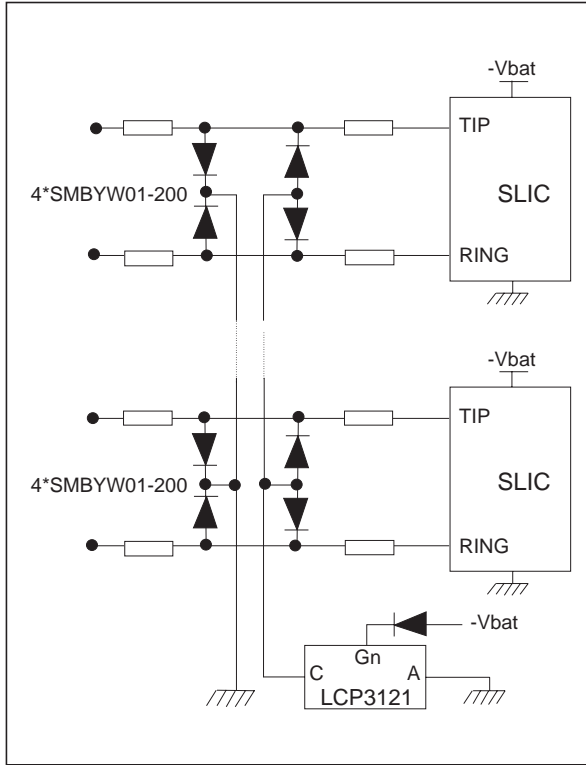

Fig. 2: Relative variation of holding current versus junction temperature (typical values).



APPLICATION EXAMPLES

Application 1: Common protection for SLIC without integrated ring generator



Application 2: Common protection for SLIC with integrated ring generator

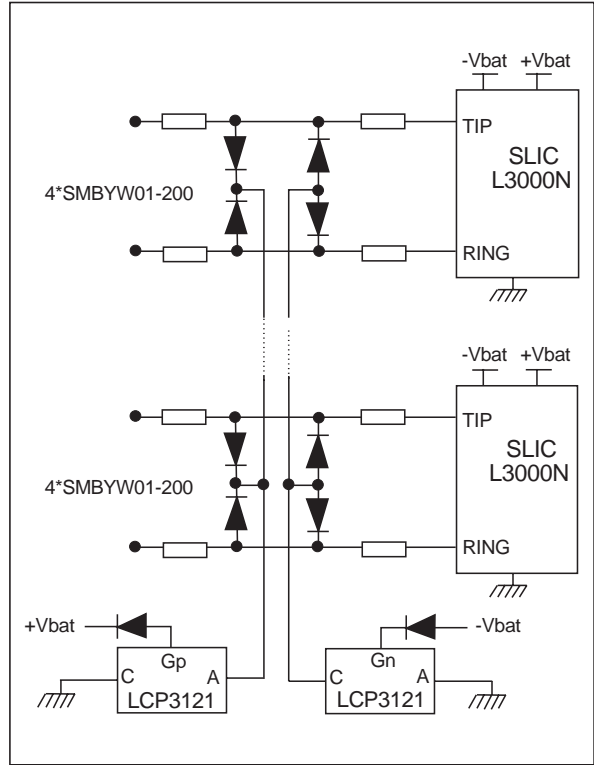

Application 3: Typical SLIC protection

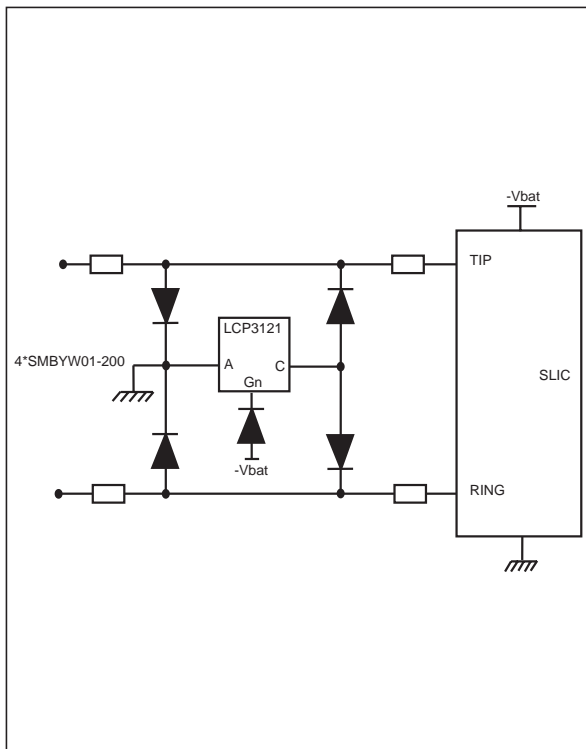

Application 4: Protection programmed by current for any application

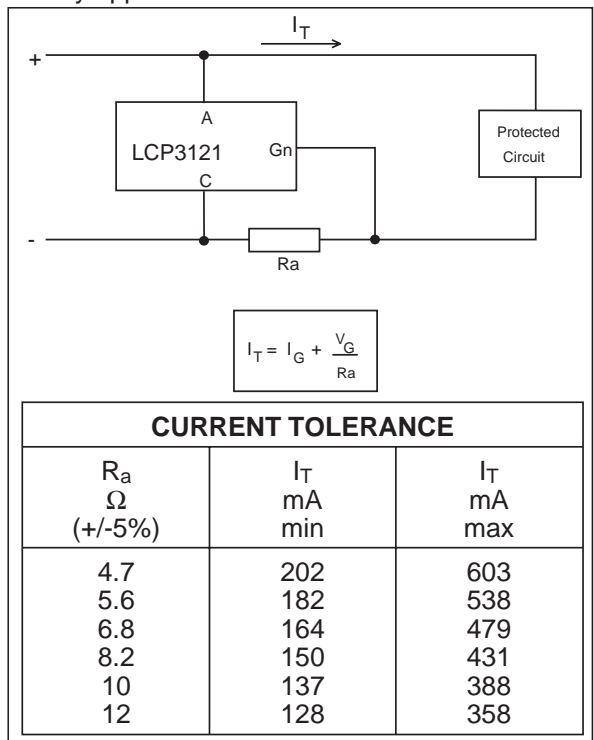

LCP3121

ORDER CODE

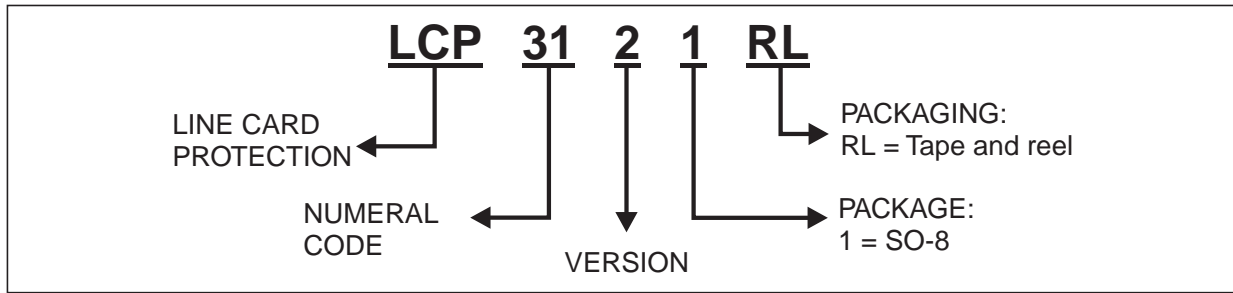

PACKAGE MECHANICAL DATA

SO-8 Plastic

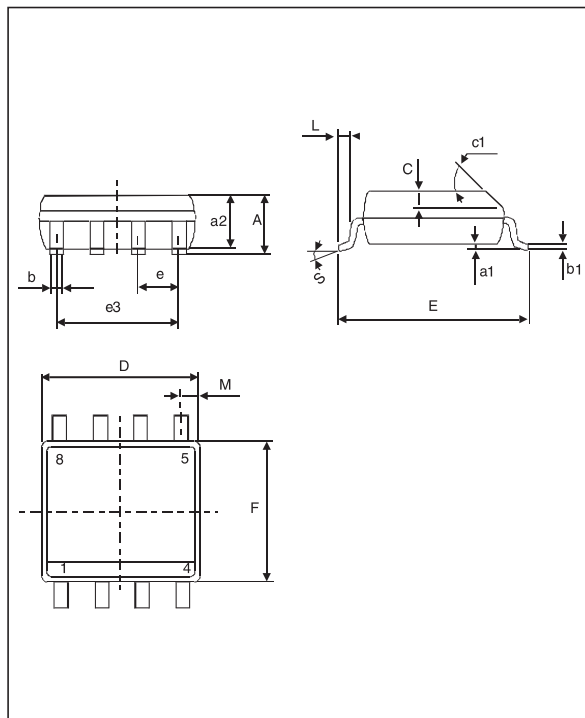

REF.	DIMENSIONS					
	Millimetres			Inches		
	Min.	Typ.	Max.	Min.	Typ.	Max.
A			1.75			0.069
a1	0.1		0.25	0.004		0.010
a2			1.65			0.065
b	0.35		0.48	0.014		0.019
b1	0.19		0.25	0.007		0.010
C		0.50			0.020	
c1	45° (typ)					
D	4.8		5.0	0.189		0.197
E	5.8		6.2	0.228		0.244
e		1.27			0.050	
e3		3.81			0.150	
F	3.8		4.0	0.15		0.157
L	0.4		1.27	0.016		0.050
M			0.6			0.024
S	8° (max)					

MARKING

Package	Type	Marking
SO-8	LCP3121	CP3121

Weight = 0.08 g

Packaging : Products supplied in anti-static tubes or tape and reel.

Information furnished is believed to be accurate and reliable. However, STMicroelectronics assumes no responsibility for the consequences of use of such information nor for any infringement of patents or other rights of third parties which may result from its use. No license is granted by implication or otherwise under any patent or patent rights of STMicroelectronics. Specifications mentioned in this publication are subject to change without notice. This publication supersedes and replaces all information previously supplied. STMicroelectronics products are not authorized for use as critical components in life support devices or systems without express written approval of STMicroelectronics.

The ST logo is a registered trademark of STMicroelectronics

© 2003 STMicroelectronics - Printed in Italy - All rights reserved.

STMicroelectronics GROUP OF COMPANIES

Australia - Brazil - Canada - China - Finland - France - Germany
 Hong Kong - India - Israel - Italy - Japan - Malaysia - Malta - Morocco - Singapore
 Spain - Sweden - Switzerland - United Kingdom - United States.

<http://www.st.com>