

LC03-6R2

Low Capacitance Surface Mount TVS for High-Speed Data Interfaces

The LC03-6 transient voltage suppressor is designed to protect equipment attached to high speed communication lines from ESD, EFT, and lightning.

Features

- SO-8 Package
- Peak Power - 2000 Watts 8 x 20 μ S
- ITU K.20 $I_{PP} = 40$ A (5/310 μ s)
- Bellcore 1089 (Intra-Building) 100 A (2/10 μ s)
- ESD Rating:
IEC 61000-4-2 (ESD) 15 kV (air) 8 kV (contact)
IEC 61000-4-4 (EFT) 40 A (5/50 ns)
IEC 61000-4-5 (lighting) 95 A (8/20 μ s)
- UL Flammability Rating of 94 V-0
- Pb-Free Package is Available

Typical Applications

- High Speed Communication Line Protection

MAXIMUM RATINGS

Rating	Symbol	Value	Unit
Peak Power Dissipation 8 x 20 μ S @ $T_A = 25^\circ\text{C}$ (Note 1)	P_{pk}	2000	W
Peak Pulse Current (8 x 20 μ S Waveform)	I_{PP}	100	A
Junction and Storage Temperature Range	T_J, T_{stg}	- 55 to +150	$^\circ\text{C}$
Lead Solder Temperature - Maximum 10 Seconds Duration	T_L	260	$^\circ\text{C}$

Stresses exceeding Maximum Ratings may damage the device. Maximum Ratings are stress ratings only. Functional operation above the Recommended Operating Conditions is not implied. Extended exposure to stresses above the Recommended Operating Conditions may affect device reliability.

1. Non-repetitive current pulse 8 x 20 μ S exponential decay waveform



ON Semiconductor®

<http://onsemi.com>

SO-8 LOW CAPACITANCE VOLTAGE SUPPRESSOR 2 kW PEAK POWER 6 VOLTS

PIN CONFIGURATION AND SCHEMATIC

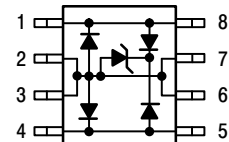

SOIC-8
CASE 751
PLASTIC

MARKING DIAGRAM

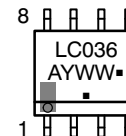

LC036 = Device Code
A = Assembly Location
Y = Year
WW = Work Week
▪ = Pb-Free Package
(Note: Microdot may be in either location)

ORDERING INFORMATION

Device	Package	Shipping†
LC03-6R2	SO-8	2500/Tape & Reel
LC03-6R2G	SO-8 (Pb-Free)	2500/Tape & Reel

†For information on tape and reel specifications, including part orientation and tape sizes, please refer to our Tape and Reel Packaging Specification Brochure, BRD8011/D.

LC03-6R2

ELECTRICAL CHARACTERISTICS

Characteristic	Symbol	Min	Typ	Max	Unit
Reverse Breakdown Voltage @ $I_t = 1.0 \text{ mA}$	V_{BR}	6.8	-	-	V
Reverse Leakage Current @ $V_{RWN} = 5.0 \text{ V}$	I_R	N/A	-	20	μA
Maximum Clamping Voltage @ $I_{PP} = 50 \text{ A}, 8 \times 20 \mu\text{S}$	V_C	N/A	-	15	V
Maximum Clamping Voltage @ $I_{PP} = 100 \text{ A}, 8 \times 20 \mu\text{S}$	V_C	N/A	-	20	V
Between I/O Pins and Ground @ $V_R = 0 \text{ V}, 1.0 \text{ MHz}$	Capacitance	-	16	25	pF
Between I/O Pins @ $V_R = 0 \text{ Volts}, 1.0 \text{ MHz}$	Capacitance	-	8.0	12	pF

TYPICAL CHARACTERISTICS

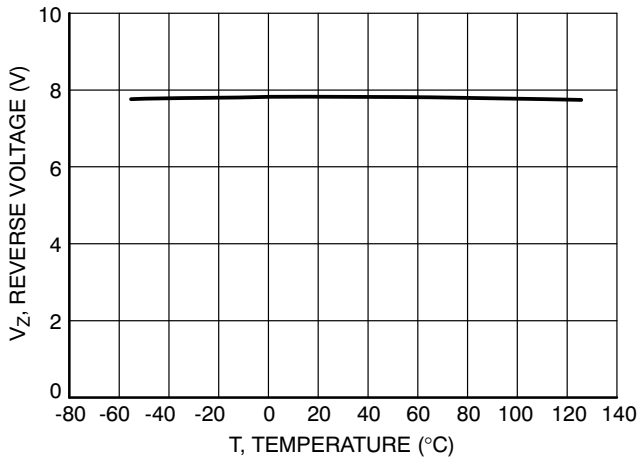

Figure 1. Reverse Voltage versus Temperature

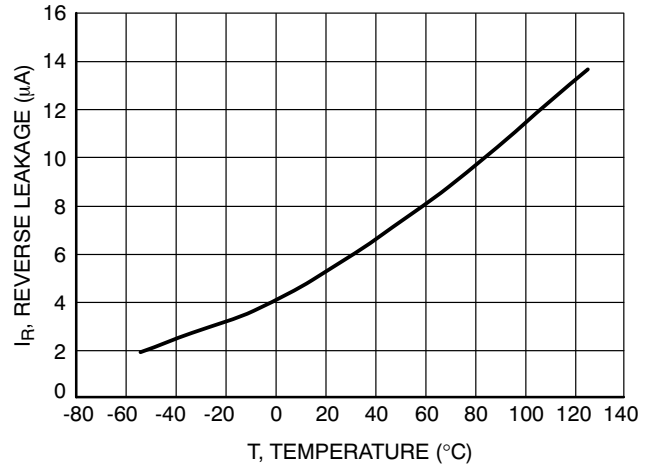

Figure 2. Reverse Leakage versus Temperature

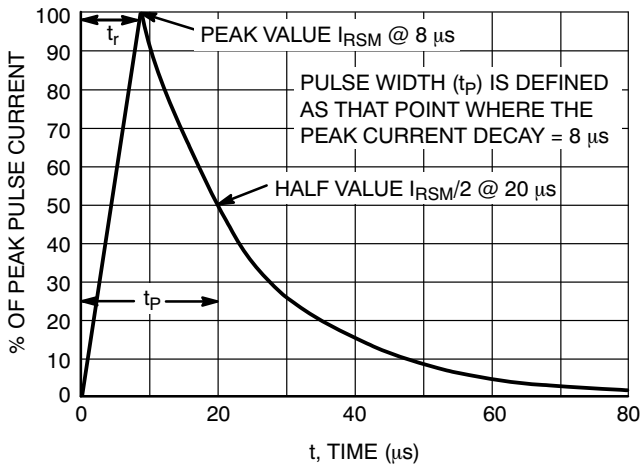

Figure 3. 8 x 20 μs Pulse Waveform

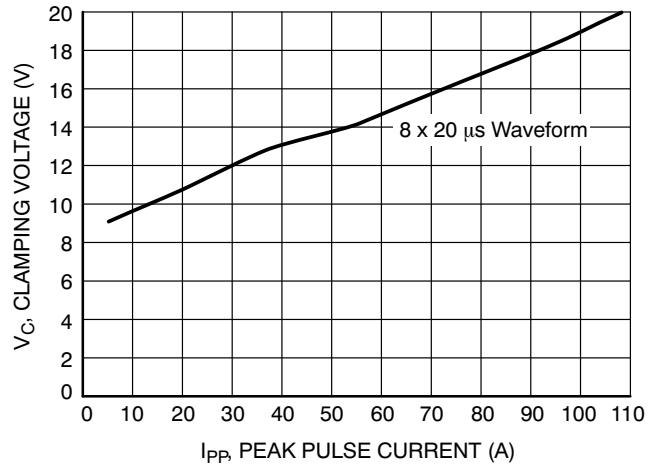

Figure 4. Clamping Voltage versus Peak Pulse Current

APPLICATIONS INFORMATION

The LC03-6 ON Semiconductor’s device is a TVS Diode array designed to protect sensitive electronics such as communications systems, computers, and computer peripherals against damage due to transient overvoltage conditions caused by lightning, electrostatic discharge (ESD), and electrical fast transients (EFT). Because of its relative low capacitance (<25 pf), it can be used in high speed I/O data lines such as USB 1.1 ports.

The integrated design of the LC03-6 device offers high surge rating, low capacitance steering diodes, and a TVS diode integrated in a single package (SO-8). In addition, this device offers compliance to Bellcore 1089 requirements (intra-building).

LC03-6 Device’s Configurations Options

Protection of Two High-speed I/O Data Lines

The LC03-6 device is able to protect two high speed data lines against transient overvoltage conditions by driving them to a fixed reference point for clamping purposes. Depending in the application’s requirements, the LC03-6 device can be configured for protection in either differential mode (Line-to-Line) or common mode (Line-to-ground). The Figure 5 shows the connection for Differential mode (Line-to-Line) and Common mode (Line-to-Ground) protection. The inputs and outputs of the I/O data lines are connected at terminals 1 to 8, and 4 to 5 while the terminals 2, 3, 6 and 7 are connected to ground; for better performance, it is recommended to minimize parasitic inductances by using ground planes and minimizing the PCB trace lengths for the ground return connections.

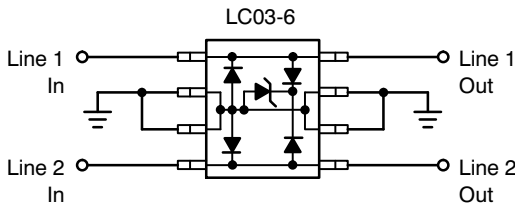

Figure 5. Configuration for Differential and Common Mode Protection

If differential protection is required by some particular applications, then the configuration for differential protection is made as shown in the Figure 6:

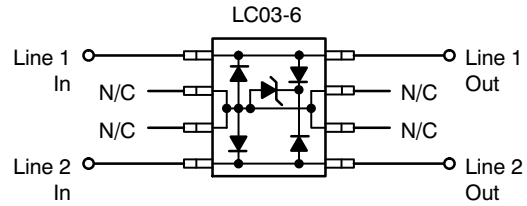

Figure 6. Configuration for Differential Protection (Line-to-Line)

T1/E1 Linecard Protection (Intra-Building)

The Figure 7 shows a typical schematic for a T1/E1 line card protection circuit. The LC03-6 device is connected between Tip and Ring on the transmit and receive line pairs. it provides protection to metallic and common mode lightning surges per Bellcore 1089 intra-building (For further information, see Bellcore 1089 standard). A metallic voltage is defined as a difference of potential between the T and R terminals of a telecommunications pair. Currents caused by lightning, in the absence of protector operation and with balanced terminal equipment and telecommunications loop, cause Tip and Ring conductors to attain the same potential hence do not produce metallic transients. Common mode surges are suppressed by the isolation of the transformer.

LC03-6R2

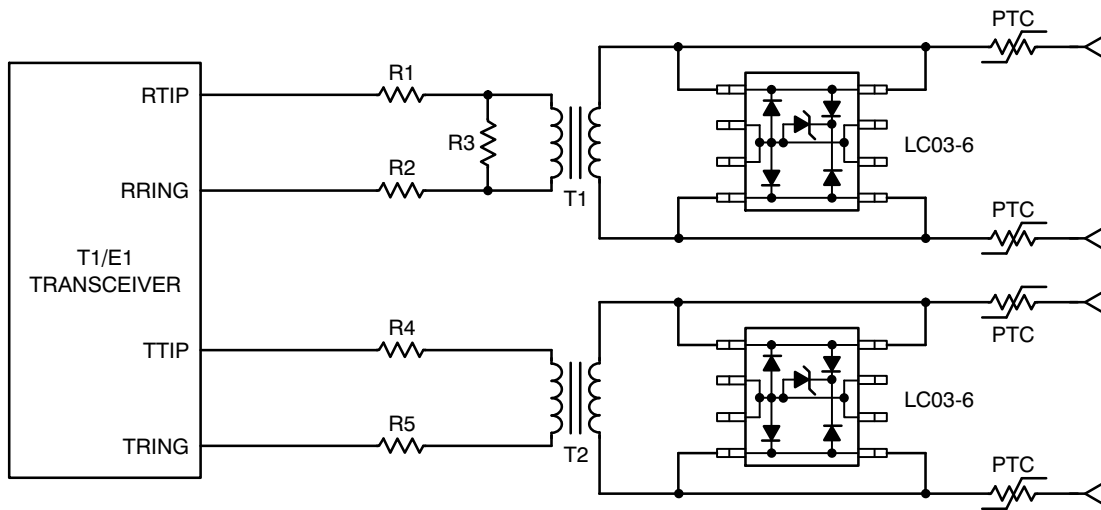

Figure 7. Typical T1 Line Card Protection

ESD Protection in USB 1.1 Port Applications

As we know, a USB port is composed of four lines. The lines D+ and D- are used for bi-directional data transmission, and the remaining two lines are reserved for bus voltage and ground. Since USB is a hot plugging and unplugging system, all its four lines have the risk to receive ESD conditions in the real field of the application.

Typical ESD protection techniques are commonly formed by the combination of different discrete semiconductor products which make this technique obsolete and non-efficient because the interconnections of the discrete devices increase the parasitic inductance effects during a

transient condition which reduces significantly the performance of the ESD protection circuit. The LC03-6 device provides a unique TVS Diode array designed to protect two I/O data lines (single USB port) against damage due to ESD conditions or transient voltage conditions. Because of its low capacitance, it can be used in high speed I/O data lines such as USB 1.1 components. In addition to its low capacitance characteristics, the LC03-6 device from ON Semiconductor complies with the most common industrial standards for ESD, EFT and surge protection: IEC61000-4-2, IEC61000-4-4, IEC61000-4-5.

LC03-6R2

PACKAGE DIMENSIONS

SOIC-8 NB
CASE 751-07
ISSUE AH

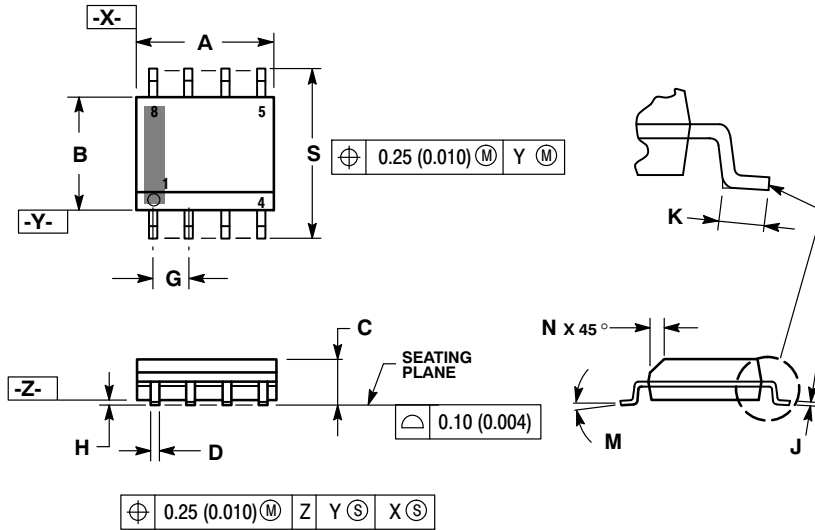

NOTES:

1. DIMENSIONING AND TOLERANCING PER ANSI Y14.5M, 1982.
2. CONTROLLING DIMENSION: MILLIMETER.
3. DIMENSION A AND B DO NOT INCLUDE MOLD PROTRUSION.
4. MAXIMUM MOLD PROTRUSION 0.15 (0.006) PER SIDE.
5. DIMENSION D DOES NOT INCLUDE DAMBAR PROTRUSION. ALLOWABLE DAMBAR PROTRUSION SHALL BE 0.127 (0.005) TOTAL IN EXCESS OF THE D DIMENSION AT MAXIMUM MATERIAL CONDITION.
6. 751-01 THRU 751-06 ARE OBSOLETE. NEW STANDARD IS 751-07.

DIM	MILLIMETERS		INCHES	
	MIN	MAX	MIN	MAX
A	4.80	5.00	0.189	0.197
B	3.80	4.00	0.150	0.157
C	1.35	1.75	0.053	0.069
D	0.33	0.51	0.013	0.020
G	1.27 BSC		0.050 BSC	
H	0.10	0.25	0.004	0.010
J	0.19	0.25	0.007	0.010
K	0.40	1.27	0.016	0.050
M	0 °	8 °	0 °	8 °
N	0.25	0.50	0.010	0.020
S	5.80	6.20	0.228	0.244

SOLDERING FOOTPRINT*

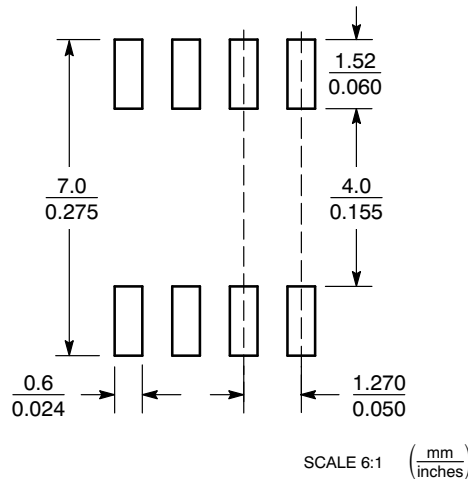

*For additional information on our Pb-Free strategy and soldering details, please download the ON Semiconductor Soldering and Mounting Techniques Reference Manual, SOLDERRM/D.

ON Semiconductor and are registered trademarks of Semiconductor Components Industries, LLC (SCILLC). SCILLC reserves the right to make changes without further notice to any products herein. SCILLC makes no warranty, representation or guarantee regarding the suitability of its products for any particular purpose, nor does SCILLC assume any liability arising out of the application or use of any product or circuit, and specifically disclaims any and all liability, including without limitation special, consequential or incidental damages. "Typical" parameters which may be provided in SCILLC data sheets and/or specifications can and do vary in different applications and actual performance may vary over time. All operating parameters, including "Typicals" must be validated for each customer application by customer's technical experts. SCILLC does not convey any license under its patent rights nor the rights of others. SCILLC products are not designed, intended, or authorized for use as components in systems intended for surgical implant into the body, or other applications intended to support or sustain life, or for any other application in which the failure of the SCILLC product could create a situation where personal injury or death may occur. Should Buyer purchase or use SCILLC products for any such unintended or unauthorized application, Buyer shall indemnify and hold SCILLC and its officers, employees, subsidiaries, affiliates, and distributors harmless against all claims, costs, damages, and expenses, and reasonable attorney fees arising out of, directly or indirectly, any claim of personal injury or death associated with such unintended or unauthorized use, even if such claim alleges that SCILLC was negligent regarding the design or manufacture of the part. SCILLC is an Equal Opportunity/Affirmative Action Employer. This literature is subject to all applicable copyright laws and is not for resale in any manner.

PUBLICATION ORDERING INFORMATION

LITERATURE FULFILLMENT:
Literature Distribution Center for ON Semiconductor
P.O. Box 5163, Denver, Colorado 80217 USA
Phone: 303-675-2175 or 800-344-3860 Toll Free USA/Canada
Fax: 303-675-2176 or 800-344-3867 Toll Free USA/Canada
Email: orderlit@onsemi.com

N. American Technical Support: 800-282-9855 Toll Free
USA/Canada
Europe, Middle East and Africa Technical Support:
Phone: 421 33 790 2910
Japan Customer Focus Center
Phone: 81-3-5773-3850

ON Semiconductor Website: www.onsemi.com
Order Literature: <http://www.onsemi.com/orderlit>
For additional information, please contact your local Sales Representative