

## DMOS DUAL FULL BRIDGE DRIVER

- 2 INDEPENDENTLY CONTROLLED H-BRIDGES
- $R_{DS,ON} < 0.9\Omega$  @  $T_{amb} = 25^\circ C, V_s = 14V$
- 0.8A DC CURRENT WITHOUT HEAT SINK
- LOW QUIESCENT MODE  $I_q < 200\mu A$
- THERMAL PROTECTION
- CROSS CONDUCTION PROTECTION
- SUPPLY VOLTAGE UP TO 40V
- CMOS COMPATIBLE INPUTS
- OUTPUT SHORT-CIRCUIT PROTECTION

### DESCRIPTION

The L9925 is a dual full bridge driver for stepper motor applications. Realized in BCD (Bipolar, CMOS & DOS) technology, logic circuits, precise linear blocks and power transistors are combined to optimize circuit performance and minimize off chip components. Schmitt triggers are used for all input stages and are fully compatible with 5V CMOS logic levels. When both enable signals are low, the IC is commanded to a low quiescent current state and will draw less than 200 $\mu A$  from the battery.

### BLOCK DIAGRAM

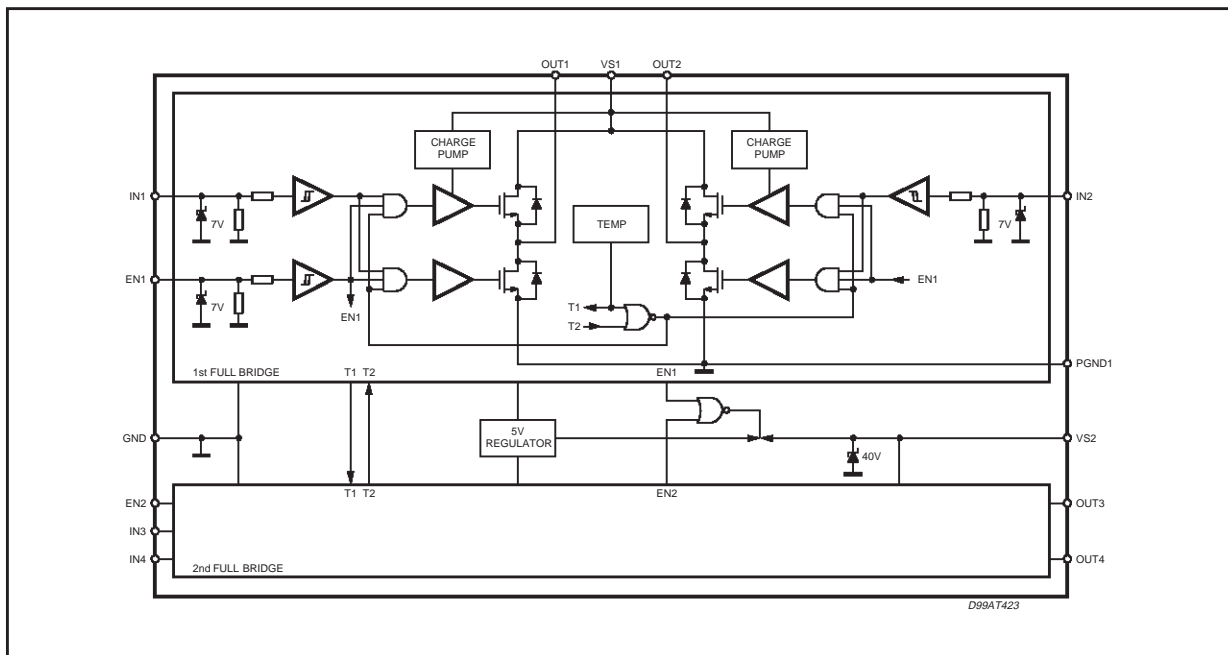

The charge pump is integrated on chip; no external components are required. Full performance is maintained for  $9V < V_s < 16V$ . Extended ranges of  $6V < V_s < 9V$  and  $16V < V_s < 40V$  yields full functionality but with relaxed performance. Over temperature protection and ESD protection to all pins ensures reliability and reduces system integration failures.

**ABSOLUTE MAXIMUM RATINGS**

Absolute Maximum Ratings are those values beyond which damage to the device may occur. Functional operation under these condition isn't implied.

For voltages and currents applied externally to the device:

Symbol	Parameter	Value	Unit
V <sub>VSDC</sub>	Dc Supply Voltage	-0.3 to 26	V
V <sub>VSP</sub>	Supply Voltage Pulse (T ≤ 400ms) <sup>(1)</sup>	40	V
I <sub>OUT</sub>	DC Output Load Current	±1.2	A
I <sub>OUT MAX</sub>	DC Output Current: for V <sub>OUT</sub> > V <sub>VS</sub> + 0.3V or V <sub>OUT</sub> < -0.3V the internal DMOS reverse and/or substrate diode become conductive and the applied current should not exceed the specified limit.	±1.8	A
V <sub>IN1,2</sub>	DC Input Voltage	-0.3 to 7	V
V <sub>EN</sub>	Enable Input Voltage	-0.3 to 7	V
T <sub>stg</sub> , T <sub>j</sub>	Storage and Junction Temperature	-40 to 150	°C
P <sub>tot</sub>	Total Power Dissipation (T <sub>pins</sub> = 80°C) (T <sub>amb</sub> = 70°C no copper area on PCB) (T <sub>amb</sub> = 70°C 8cm <sup>2</sup> copper area on PCB)	5	W
		1.23	W
		2	W

(1) Device may be overstressed if pulsed simultaneous with short circuit at one or more of the outputs will be present.

**PIN CONNECTION**

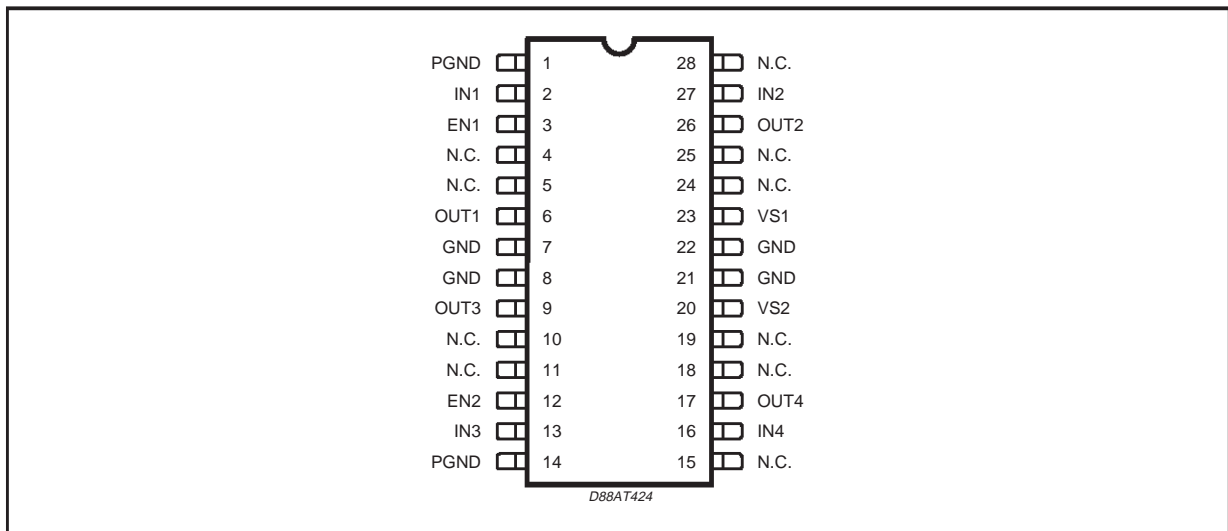

**THERMAL DATA**

Symbol	Parameter	Value	Unit
T <sub>JTS</sub>	Thermal Shut-down junction temperature min.	150	°C
T <sub>JTSH</sub>	Thermal Shut-down threshold hysteresis typ.	25	°C
R <sub>th j-amb</sub>	Thermal Resistance Junction-ambient <sup>(2)</sup>	50	°C/W
R <sub>th j-pins</sub>	Thermal Resistance Junction-pins	15	°C/W

<sup>(2)</sup> With 6cm<sup>2</sup> on board heat sink area

## PIN FUNCTIONS

N.	Name	Function
1	PGND1	Ground for DMOS sources in bridge 1
2	IN1	Digital Input from motor controller for bridge 1
3	EN1	Logic enable/disable for bridge 1 (active high)
4, 5	NC	No connect
6	OUT1	Output of one half of bridge 1
7, 8	GND	Ground
9	OUT3	Output of one half of bridge 2
10, 11	NC	No connect
12	EN2	Logic enable/disable for bridge 2 (active high)
13	IN3	Digital Input from motor controller for bridge 2
14	PGND2	Ground for DMOS sources in bridge 2
15	NC	No connect
16	IN4	Digital Input from motor controller for bridge 2
17	OUT4	Output of one half of bridge 2
18, 19	NC	No connect
20	VS2	Supply Voltage for bridge 2
21, 22	GND	Ground
23	VS1	Supply Voltage for bridge 1
24, 25	NC	No connect
26	OUT2	Output of one half of bridge 1
27	IN2	Digital Input from motor controller for bridge 1
28	NC	No connect

ELECTRICAL CHARACTERISTICS ( $V_s = 9$  to  $16V$ ;  $T_j = -40$  to  $150^\circ C$  <sup>(3)</sup>, unless otherwise specified.)

Symbol	Parameter	Test Condition	Min.	Typ.	Max.	Unit
I <sub>s</sub>	Quiescent Current	EN1 = EN2 = 0V; T <sub>j</sub> = 85°C			200	μA
		EN1 = EN2 = 5V; I <sub>load</sub> = 0A		5	12	mA
R <sub>ds</sub>	Switch on Resistance	T <sub>j</sub> = 25°C; V <sub>s</sub> = 14V; I <sub>o</sub> = 300mA		0.75	0.8	Ω
		T <sub>j</sub> = 125°C; V <sub>s</sub> = 6V; I <sub>o</sub> = 300mA		1.5	1.9	Ω
T <sub>d-on</sub>	Turn-on delay	See Fig 1		10	50	μs
T <sub>d-SB</sub>	Standby setting time	See Fig 1		50	200	μs
T <sub>d-off</sub>	Turn-off delay	See Fig 1		10	50	μs
t <sub>rise</sub>	Output rise time (10 to 90%)	See Fig 1	0.5	5	20	μs
t <sub>fall</sub>	Output fall time (90 to 10%)	See Fig 1	0.5	5	20	μs
I <sub>Lo</sub>	Output leakage current	EN = 0V; V <sub>o</sub> = V <sub>s</sub> or GND	-10		10	mA
IN <sub>x</sub> , EN <sub>x</sub>	Logic Input Low voltage		-0.3		1.5	V
	Logic Input High voltage		3.5		6	V
	Hysteresis		0.5	1.0	2.0	V
I <sub>bias</sub>	Input bias current		-50		300	μA

The voltage referred to GND and currents are assumed positive, when the current flows into the pin.

(3) Tested up to 125°C, parameter guaranteed by correlation up to 150°C

**Logic Levels**

All inputs are positive, non inverting logic

Logic State	Voltage Range
0	-0.3 to 1.5V
1	3.5 to 6.0V

**Truth Table**

Enable/ Disable

EN1	EN0	Bridge 1	Bridge 2	Iq
0	0	Disabled	Disabled	<200μA
0	1	Disabled	Enabled	<12mA
1	0	Enabled	Disabled	<12mA
1	1	Enabled	Enabled	<12mA

**General Operation**

With the bridge enabled, each input INx, maps directly to the corresponding output OUTx.

The output voltage will be equal to the difference between the supply rail and the product of the load current and the on resistance of the output switch.  $V_{out} = V_{supply} - (R_{DS,ON} \cdot I_{LOAD})$ .

Sourced load currents are positive.

IN1	OUT1	IN2	OUT2	IN3	OUT3	IN4	OUT4
0	0	0	0	0	0	0	0
1	Vs	1	Vs	1	Vs	1	Vs

**Figure 1. Timing Diagram**

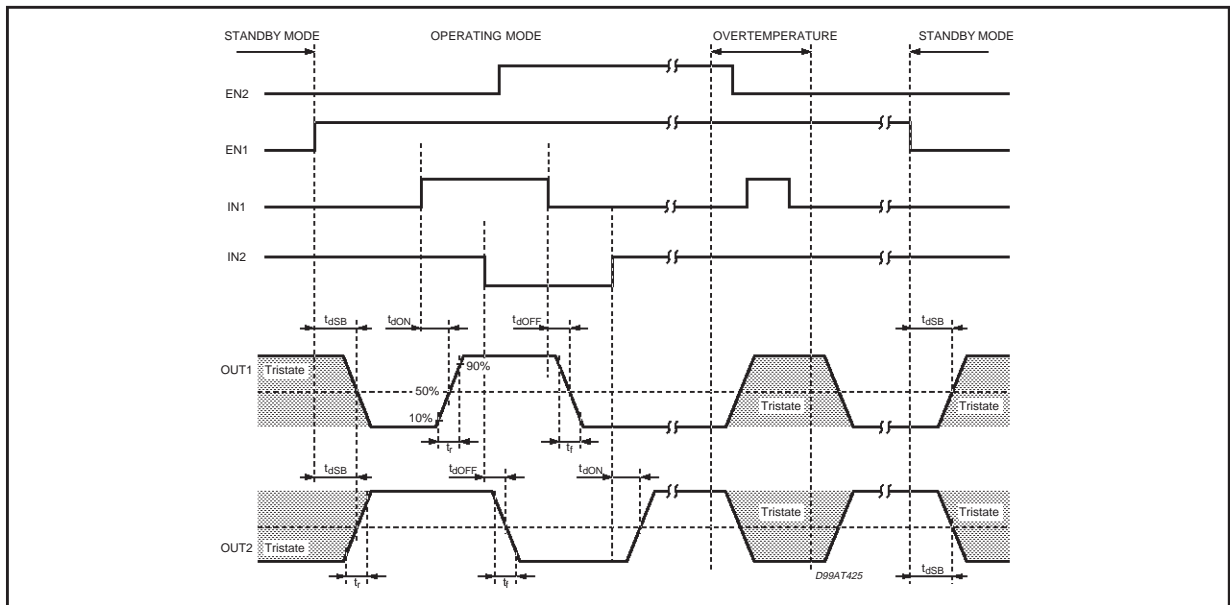

**Figure 2. Typical RON - Characteristics of Source and Sink Stage**

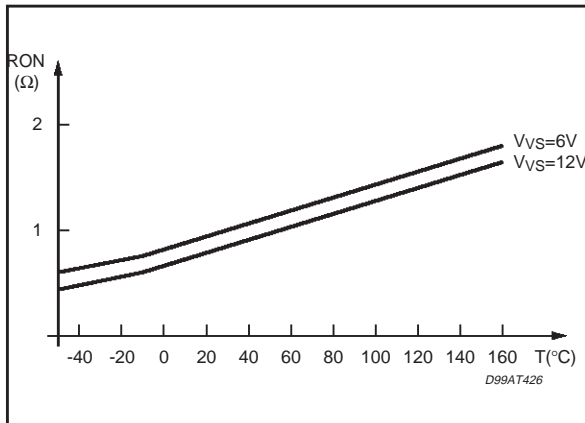

**Figure 3. ON - Resistance vs Supply Voltage**

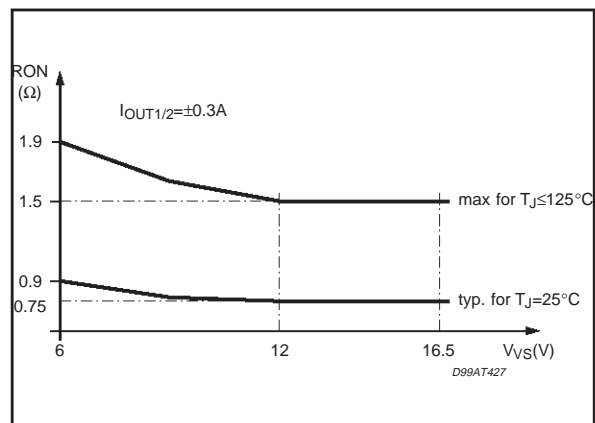

Figure 4. Application Diagram

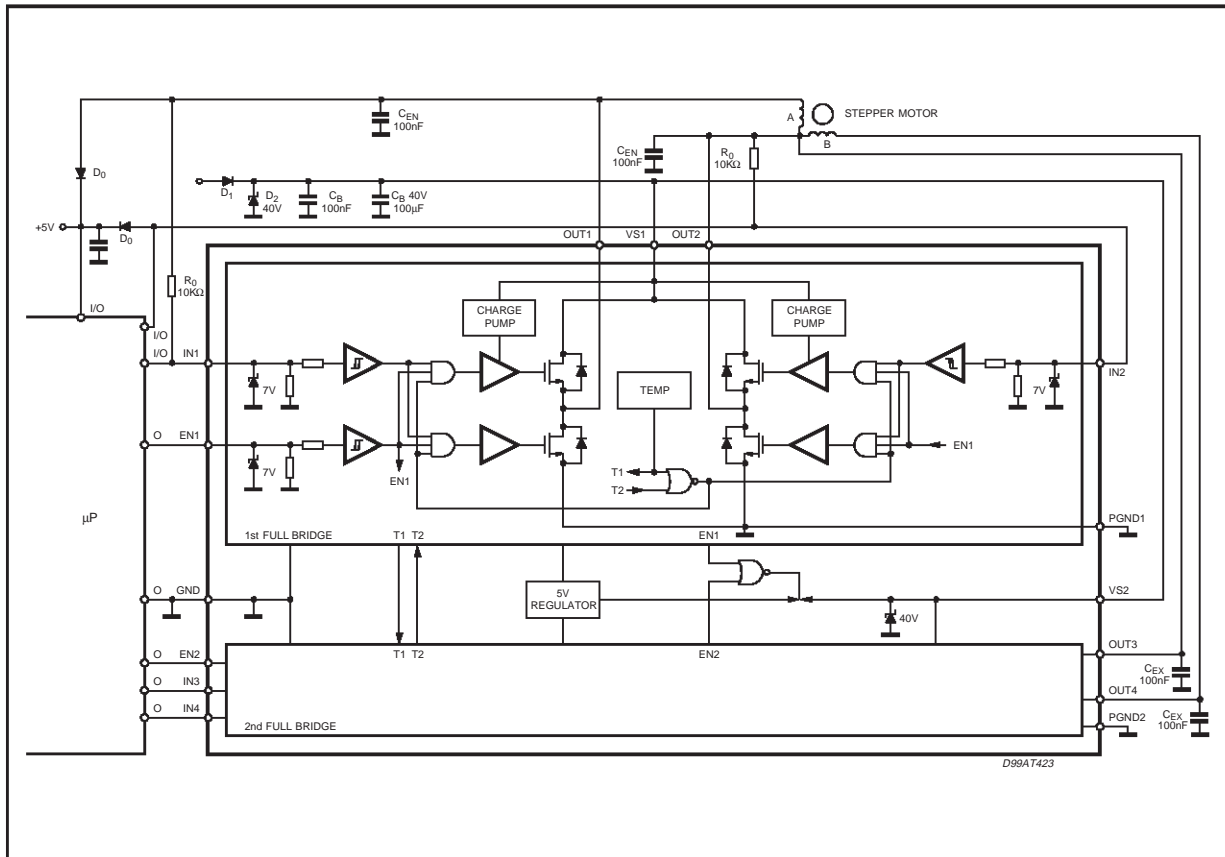

Figure 4 shows a typical application diagram for DC motor driving. To assure the safety of the circuit in the reverse battery condition a reverse protection diode D1 is necessary. The transient protection diode D2 must assure that the maximum supply voltage Vs during the transients at the VBAT line will be limited to a value lower than the absolute maximum ratings for Vvsp. The capacities CB are used to lower Vs-EMR and its values depend on the driving load.

The resistance feedback loop realized by R0 limited to the µP power supply line by the diode D0 allows open load detection. To protect the device at the outputs against EMI or ESD > 2KV external capacitors Cex may be used.

**CIRCUIT DESCRIPTION**

L9925 is a dual full bridge IC designed to drive DC motors, stepper motors and other inductive loads. Each bridge has 4 power DMOS transistor with RDSon = 0.75Ω and the relative protection and control circuitry (see fig. 5). The 4 half bridges can be controlled independently by means of the 4 inputs IN1, IN3, IN4 and 2 enable inputs ENABLE1 and ENABLE2.

**LOGIC DRIVE (true table for the two full bridges)**

	INPUTS		OUTPUT MOSFETS
	IN1 IN3	IN2 IN4	
EN1 = EN2 = H	L L H H	L H L H	Sink 1, Sink2 Sink1, Source2 Source1, Sink2 Source1, Source2
@Tj > 150°C	X	X	All transistors turned OFF
EN1 = EN2 = L	X	X	All transistors turned OFF

L = Low; H = High; X = Don't care

**CROSS CONDUCTION**

The device guarantees the absence of cross-conduction by watching internal gate-source voltage of the driving power DMOS.

**TRANSISTOR OPERATION**

**ON STATE**

When one of POWER DMOS transistors is ON it can be considered as a resistor RDS(ON) = 0.75Ω at a junction temperature of 25°C



In this condition the dissipated power is given by:

$$P_{ON} = R_{DS(ON)} \cdot I_{DS}^2$$

The low  $R_{DS(ON)}$  of the Multipower BCD process can provide high currents with low power dissipation.

**OFF STATE**

When one of the POWER DMOS transistor is OFF the  $V_{DS}$  voltage is equal to the supply voltage and only the leakage current  $I_{DSS}$  flows.

The power dissipation during this period is given by:

$$P_{OFF} = V_s \cdot I_{DSS}$$

**Figure 5a.** Two phase chopping

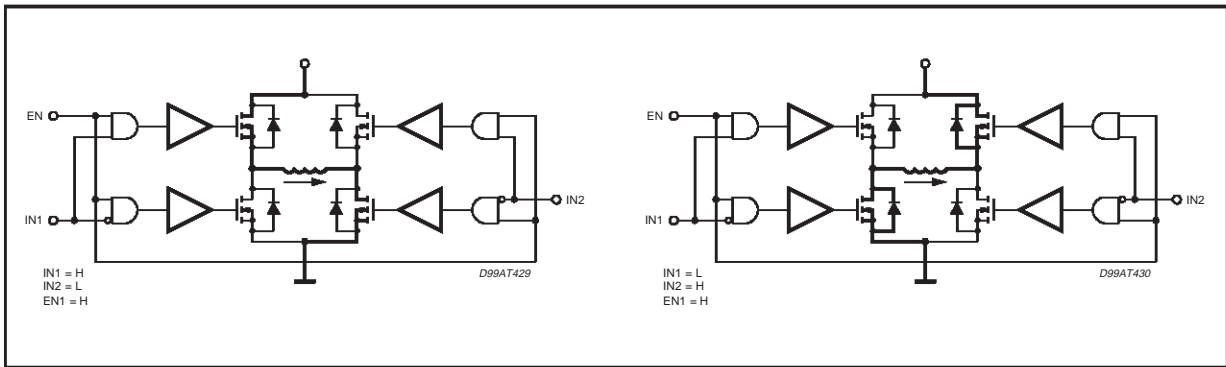

**Figure 5b.** One phase chopping

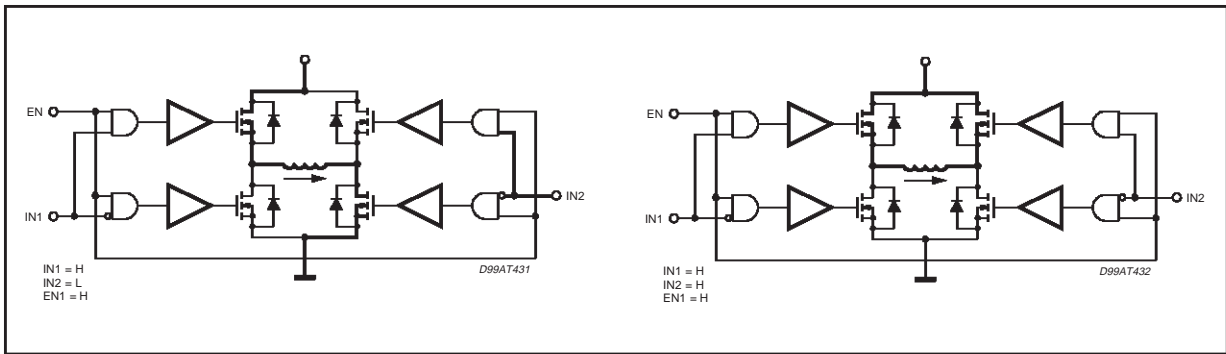

**Figure 5c.** Enable chopping

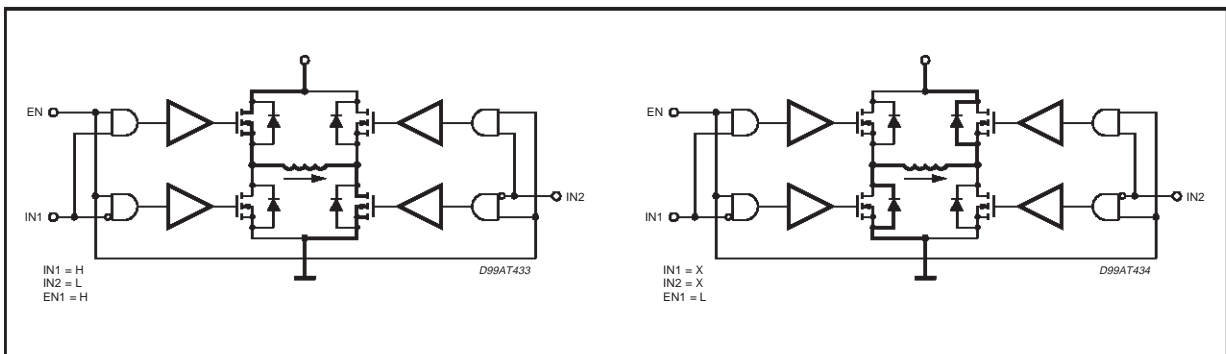

**TRANSITIONS**

Like all MOS power transistors the DMOS POWER transistors have an intrinsic diode between their source and drain that can operate as a fast freewheeling diode in switched mode applications. During recirculation with the ENABLE input is low, the POWER MOS is OFF and the diode voltage it is clamped to its characteristics. When the ENABLE input is low, the POWER MOS is OFF and the diode carries all of the recirculation current. The power dissipated in the transitional times in the cycle depends upon the voltage and current waveforms in the application.

$$P_{trans} = I_{DS}(t) \cdot V_{DS}(t)$$

## THERMAL PROTECTION

A thermal protection circuit has been included that will disable the device if the junction temperature reaches 150°C. When the temperature has fallen to a safe level the device restarts under the control of the input and enable signals.

## APPLICATION INFORMATION

### RECIRCULATION

During recirculation with the ENALBE input high, the voltage drop across the transistor is  $R_{DS(ON)}$  for voltages less than 0.6V and is clamped at a voltages depending on the characteristics of the source-drain diode for greater voltages. Although the device is protected against cross conduction.

### POWER DISSIPATION each bridge

In order to achieve the high performance provided by the L9925 some attention must be paid to ensure that it has an adequate PCB area to dissipate the heat. The first stage of any thermal design is to calculate the dissipated power in the application, for this example the half step operation shown in Fig. 6 is considered.

### RISE TIME $T_R$

When an arm of the half bridge is turned on current begins to flow in the inductive load until the maximum current  $I_L$  is reached after a time  $T_R$ . The dissipated energy  $E_{OFF/ON}$ .

$$E_{OFF/ON} = [R_{DS(ON)} \cdot I_L^2 \cdot T_R] \cdot \frac{2}{3}$$

Figure 6.

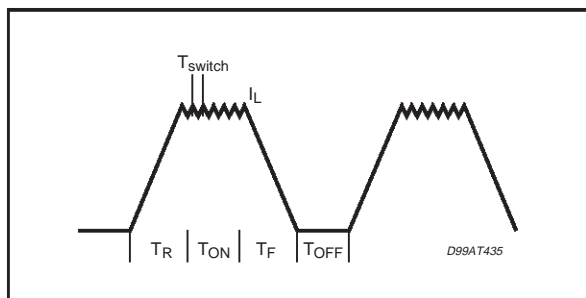

### ON TIME $T_{ON}$

During this time the energy dissipated is due to the ON resistance of the transistors  $E_{ON}$  and the

commutation  $E_{COM}$ . As two of the POWER DMOS transistors are ON  $E_{ON}$  is given by:

$$E_{ON} = I_L^2 \cdot R_{DS(ON)} \cdot 2 \cdot T_{ON}$$

In the commutation the energy dissipated is:

$$E_{CON} = V_S \cdot I_L \cdot T_{COM} \cdot f_{SWITCH} \cdot T_{ON}$$

Where:

$T_{COM}$  = Commutation Time and it is assumed that;

$T_{COM} = t_{rise} = t_{fall} \leq 20\mu s$

$T_{SWITCH}$  = Chopper frequency

### FALL TIME $T_F$

For this example it is assumed that the energy dissipated in this part of the cycle takes the same form as that shown for the rise time:

$$E_{OFF/ON} = [R_{DS(ON)} \cdot I_L^2 \cdot T_F] \cdot \frac{2}{3}$$

### QUIESCENT ENERGY

The last contribution of the energy dissipation is due to the quiescent supply current and is given by:

$$E_{QUIESCENT} = I_{QUIESCENT} \cdot V_S \cdot T$$

### TOTAL ENERGY PER CYCLE

$$E_{TOT} = (2 \cdot E_{OFF/ON} + E_{ON} + E_{COM})_{bridge1} + (2 \cdot E_{OFF/ON} + E_{ON} + E_{COM})_{bridge2} + E_{QUIESCENT}$$

The total power dissipation  $P_{DIS}$  is simply:

$$P_{DIS} = \frac{E_{tot}}{T}$$

$T_R$  = Rise time

$T_{ON}$  = ON time

$T_F$  = Fall time

$T_{OFF}$  = OFF time

$T$  = Period

$$T = T_R + T_{ON} + T_F + T_{OFF}$$

DIM.	mm			inch		
	MIN.	TYP.	MAX.	MIN.	TYP.	MAX.
A			2.65			0.104
a1	0.1		0.3	0.004		0.012
b	0.35		0.49	0.014		0.019
b1	0.23		0.32	0.009		0.013
C		0.5			0.020	
c1	45° (typ.)					
D	17.7		18.1	0.697		0.713
E	10		10.65	0.394		0.419
e		1.27			0.050	
e3		16.51			0.65	
F	7.4		7.6	0.291		0.299
L	0.4		1.27	0.016		0.050
S	8° (max.)					

## OUTLINE AND MECHANICAL DATA

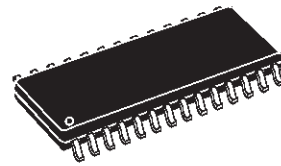

**SO28**

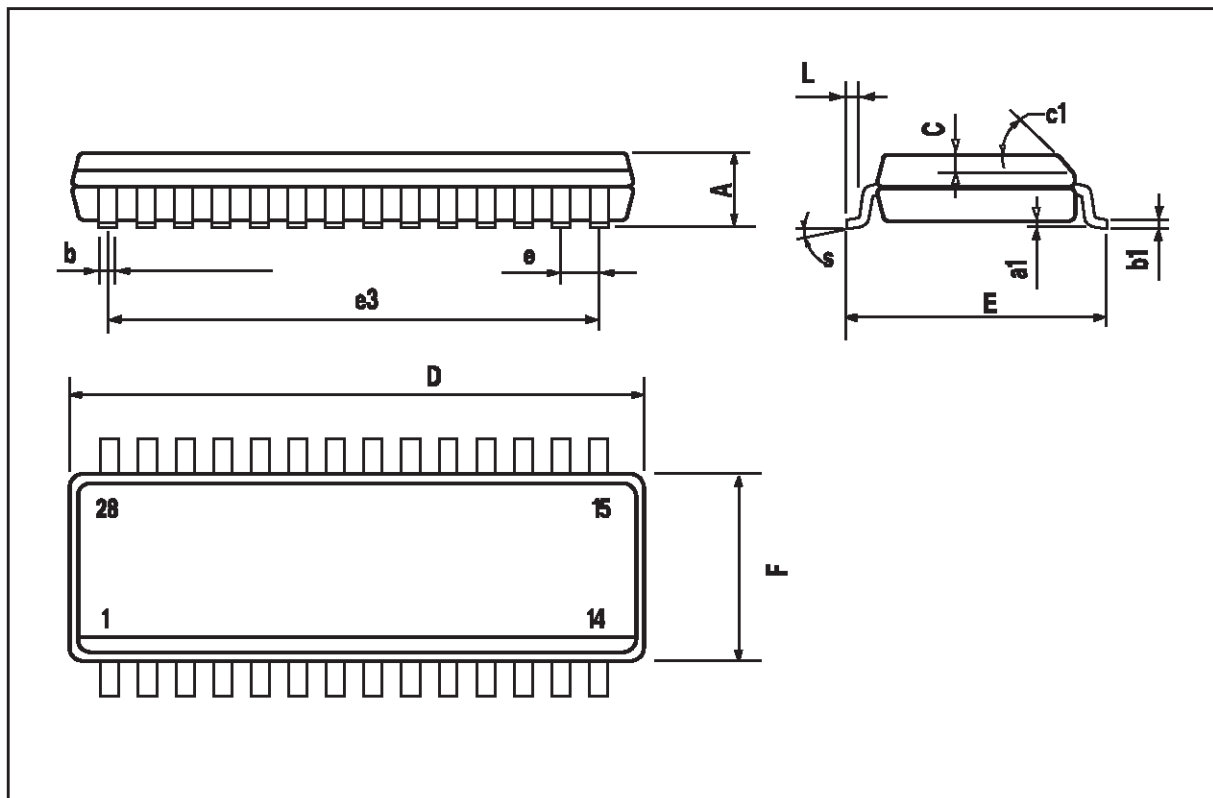



Information furnished is believed to be accurate and reliable. However, STMicroelectronics assumes no responsibility for the consequences of use of such information nor for any infringement of patents or other rights of third parties which may result from its use. No license is granted by implication or otherwise under any patent or patent rights of STMicroelectronics. Specification mentioned in this publication are subject to change without notice. This publication supersedes and replaces all information previously supplied. STMicroelectronics products are not authorized for use as critical components in life support devices or systems without express written approval of STMicroelectronics.

The ST logo is a registered trademark of STMicroelectronics

© 1999 STMicroelectronics – Printed in Italy – All Rights Reserved

STMicroelectronics GROUP OF COMPANIES

Australia - Brazil - Canada - China - France - Germany - Italy - Japan - Korea - Malaysia - Malta - Mexico - Morocco - The Netherlands - Singapore - Spain - Sweden - Switzerland - Taiwan - Thailand - United Kingdom - U.S.A.

<http://www.st.com>

