

## DC MOTOR DRIVER WITH POSITION CONTROL

### DESCRIPTION

#### Oscillator.

The output current at ROSC pin is mirrored to COSC pin with a proper direction according to its voltage slope.

The triangular wave form at COSC pin, being compared with a threshold, defines the PWM duty cycle at the motor driver output M+ and M-.

The oscillator also supplies the time base for the switch off and switch on delays and the Time Out Counter.

The typical oscillator period is:

$$T_{osc} = 7.04 \times R_{osc} \times C_{osc}$$

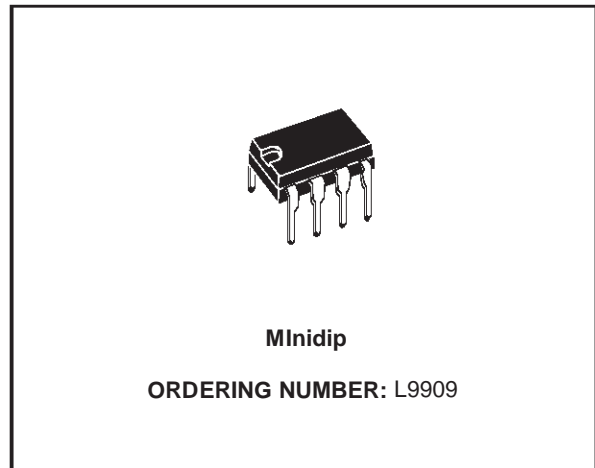

### BLOCK DIAGRAM

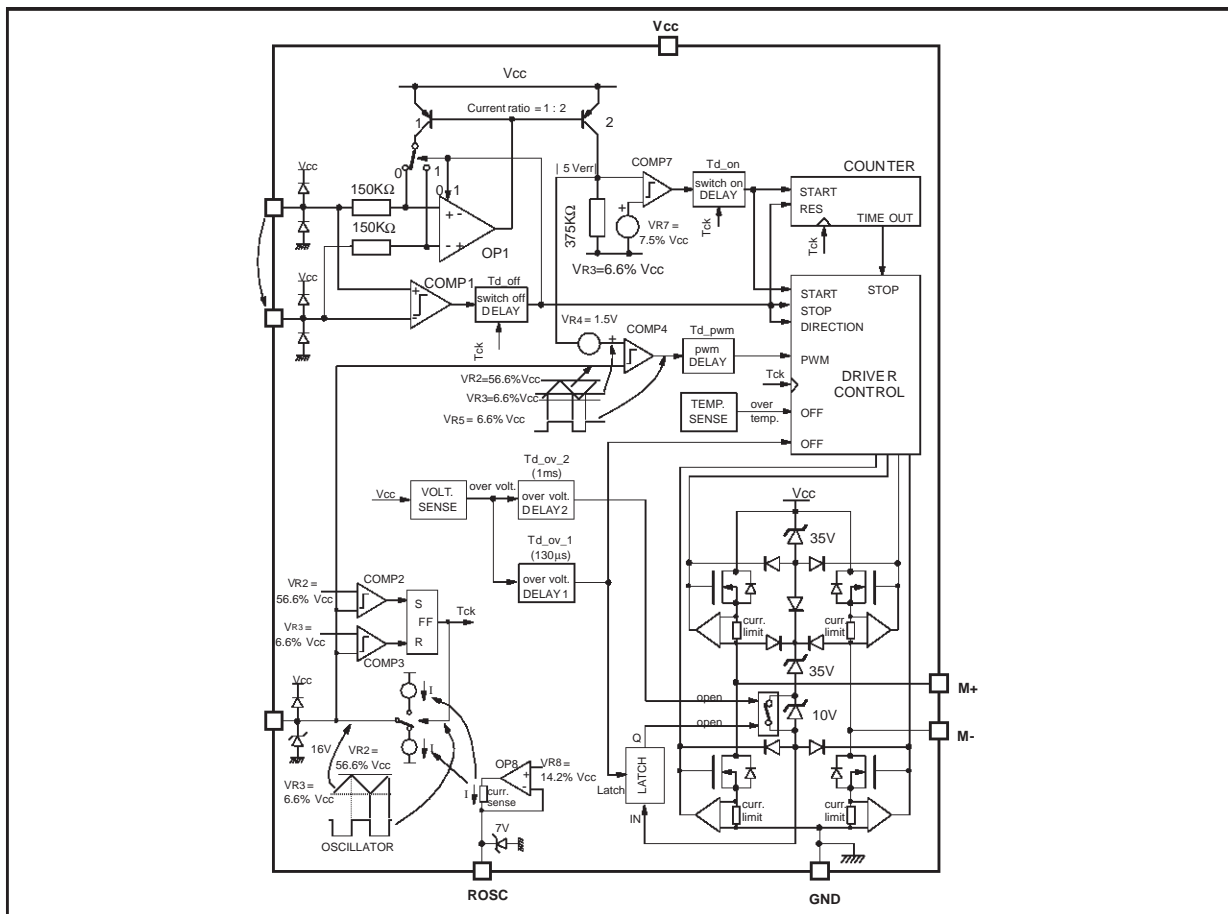

**ABSOLUTE MAXIMUM RATINGS**

Symbol	Parameter	Value	Unit
V <sub>CC</sub>	DC battery supply voltage	-0.3 to 55	V
V <sub>CC,t</sub>	Transient battery supply voltage (Figs. 4 and 5)	-0.3 to V <sub>CC,CL</sub> (*)	V
V <sub>in</sub>	Voltage at VCOM and VFB pins	-0.3 to V <sub>CC</sub> +0.3	V
V <sub>ROSC</sub>	Voltage AT ROSC pin	-0.3 to 7	V
V <sub>COSC</sub>	Voltage at COSC pin for V <sub>CC</sub> >16V	-0.3 to 16	V
	Voltage at COSC pin for V <sub>CC</sub> >16V	-0.3 to V <sub>CC</sub> +0.3	V
I <sub>CC</sub>	Current at V <sub>CC</sub> GND, M+ and M-	±1.9	A
I <sub>CC,t</sub>	Transient Current at V <sub>CC</sub> GND (figs. 4 and 5)	±4	A
I <sub>sig</sub>	Current at VFB, VCOM, COSC and ROSC	±10	mA
P <sub>d</sub>	Device Power Dissipation	internally limited	W
T <sub>j</sub>	Junction Temperature	-40 to 150	°C
T <sub>stg</sub>	Storage and Junction Temperature	-55 to 150	°C
VESD	ESD Voltage Level (Human body Model - MIL STD883C)	±2000	V

(\*) NOTE: SELF PROTECTING

Stressed above those listed under "Absolute Maximum Ratings" may cause permanent damage to the device. This is a stress rating only and functional operation of the device at any condition above those indicated in the operational section of this specification is not implied. Exposure to absolute maximum rating conditions for extended periods may affect device reliability.

**PIN CONNECTION**

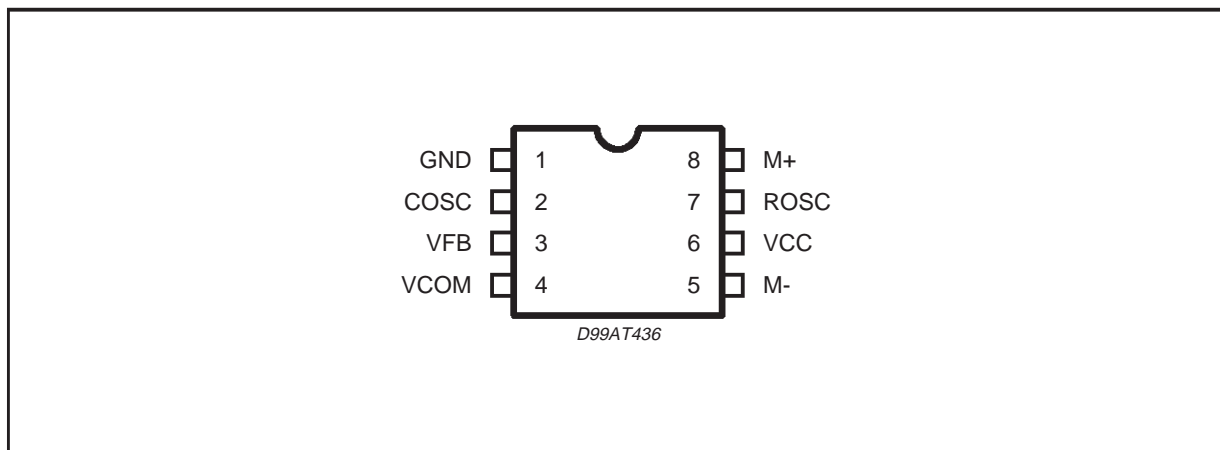

**THERMAL DATA**

Symbol	Parameter	Value	Unit
R <sub>th j-case</sub>	Thermal resistance Junction to case (pin 1)	70	°C/W

## PIN FUNCTIONS

N.	Name	Function
1	GND	Ground
2	COSC	Oscillator Capacitor
3	VFB	Position Feedback Voltage
4	VCOM	Position Command Voltage
5	M-	Negative Motor Terminal
6	VCC	Power Supply
7	ROSC	Oscillator Resistor
8	M+	Positive Motor Terminal

ELECTRICAL CHARACTERISTICS (V<sub>CC</sub> = 7 to 18V; T<sub>j</sub> = -40 to 85°C, unless otherwise specified.)

Pin	Symbol	Parameter	Test Condition	Min.	Typ.	Max.	Unit
<b>POWER SUPPLY</b>							
VCC	I <sub>CC</sub>	Quiescent Supply Current	I <sub>M+</sub> = I <sub>M-</sub> = 0, I <sub>ROSC</sub> = 100μA; V <sub>COSC</sub> = 0			10	mA
	V <sub>CC_OV</sub>	Over Voltage Shut Down		18		20	V
	V <sub>CC_OVdel</sub>	Over Voltage Shut Down Delay			130		μs
	V <sub>CC_min</sub>	Minimum V <sub>CC</sub> Operating Voltage - Other Parameter may not be in spec				5.5	V
	V <sub>CC_CL</sub>	Battery Supply Clamp Voltage	Transients of Fig.5		70	80	V
	T <sub>d_ov_1</sub>	Battery Supply Clamp Time	Transients of Fig.5		130	1000	μs
	T <sub>d_ov_2</sub>	Battery Supply Clamp Time	Transients of Fig.4		1		ms
<b>OSCILLATOR</b>							
COSC ROSC	ROSC	Oscillator Resistor		10		100	KΩ
	COSC	Oscillator Capacitor		2		100	nF
	T <sub>OUT</sub>	Timer Run Time			16384		T <sub>OSC</sub>
	F <sub>OSC</sub>	Oscillator Frequency	ROSC 27KΩ; C <sub>OSC</sub> = 10nF	430	530	630	Hz
ROSC	V <sub>ROSC</sub>	Voltage at ROsc pin	ROsc 27KΩ		14.2		%V <sub>CC</sub>
COSC	I <sub>COSC</sub>	Current at C <sub>OSC</sub> pin	ROsc 27KΩ	-20	I <sub>ROSC</sub>	20	%
	V <sub>THCOSC</sub>	High Threshold Voltage			56.6	1000	%V <sub>CC</sub>
	V <sub>TLCOSC</sub>	Low Threshold Voltage			6.6	1000	%V <sub>CC</sub>
	V <sub>LINERR</sub>	Voltage Ramp Linearity Error		-20		20	%

**ELECTRICAL CHARACTERISTICS** (continued.)

Pin	Symbol	Parameter	Test Condition	Min.	Typ.	Max.	Unit
<b>INPUT OUTPUT TRANSFER FUNCTION</b>							
VCOM	$A_V$	Input Output Gain		7	10	14	
VFB	$V_{STP}$	Stop Motor Voltage	$V_{STP} = 2 V_{R4}$	2.5	3	3.5	V
COSC	$V_{STR}$	Start Error Voltage	$V_{STR} = V_{R7/5}$	1	1.5	2	%V <sub>CC</sub>
M+	$V_{off\_c1}$	Comp 1 Input Offset Voltage	Error Voltage when the motor starts braking	-20		20	mV
M-	$T_{on}$	Switch on Delay		1		2	T <sub>OSC</sub>
	$T_{off}$	Switch off Delay		1		2	T <sub>OSC</sub>
VCOM	$R_{diff}$	Differential Input Impedance (see fig 3)	$\frac{2V_{COM} - V_{FB}}{I_{com} - I_{FB}}$	100	300		K $\Omega$
VFB	$R_{com}$	Common Mode Input (see fig 3)	$\frac{V_{COM} + V_{FB}}{I_{com} + I_{FB}}$	50			K $\Omega$
<b>OUTPUT DRIVERS</b>							
M+	$R_{ON\_H}$	High Side R <sub>DS</sub>	$I_{M+} = I_{M-} = 0.3A; V_{CC} = 13.5V$		0.6	1.5	$\Omega$
			$I_{M+} = I_{M-} = 0.3A; V_{CC} = 7V$		1	2.6	$\Omega$
M-	$R_{ON\_L}$	Low Side R <sub>DS</sub>	$I_{M+} = I_{M-} = 0.3A; V_{CC} = 13.5V$		0.6	1.5	$\Omega$
			$I_{M+} = I_{M-} = 0.3A; V_{CC} = 7V$		1	2.6	$\Omega$
	$I_{LIM}$	Output Current Limit for each of 4 Output Transistors Separately		1		1.9	A
	$T_R$	Output Rise Time	20% to 80%		20		$\mu s$
	$T_F$	Output Fall Time	80% to 20%		20		$\mu s$
	$V_{MTRAN}$	V(M+) - V(M-)  Output Voltage During V <sub>CC</sub> Transients	Transients of figs.4 and 5			20	V
	$T_{HSHDN}$	Thermal Shutdown			170		$^{\circ}C$

**Figure 1.** Static Transfer Characteristic. Error Voltage vs. Output Voltage

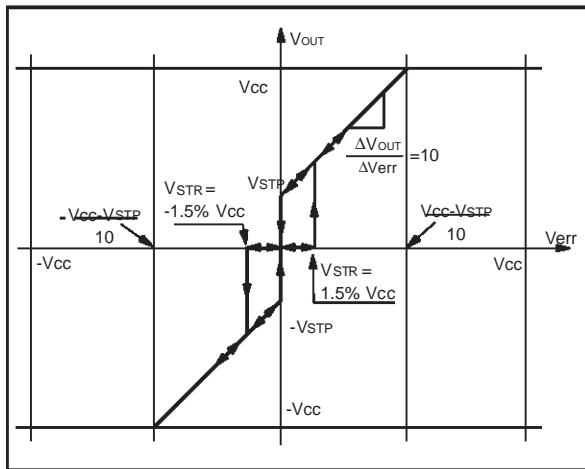

**Figure 2.** Static Transfer Characteristic. Position Error Voltage vs. Output Voltage  
Perr = Verr/Vcc

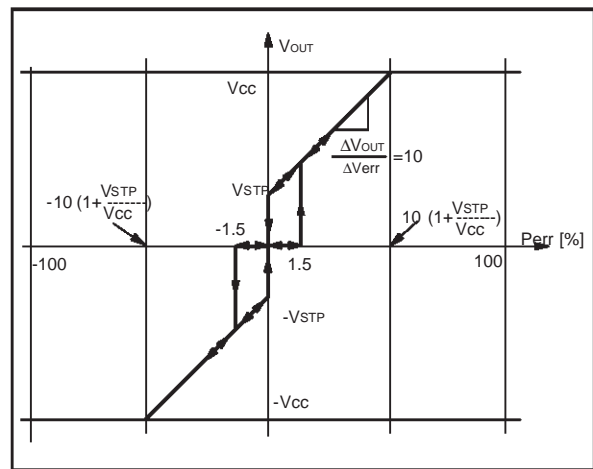

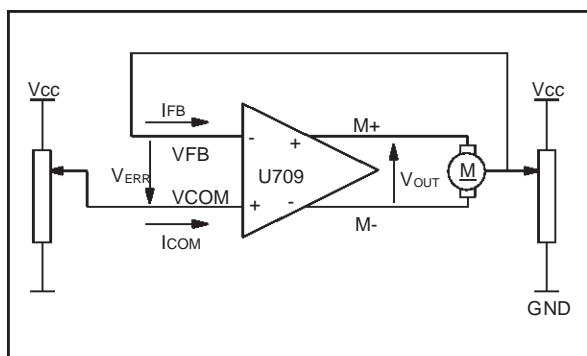
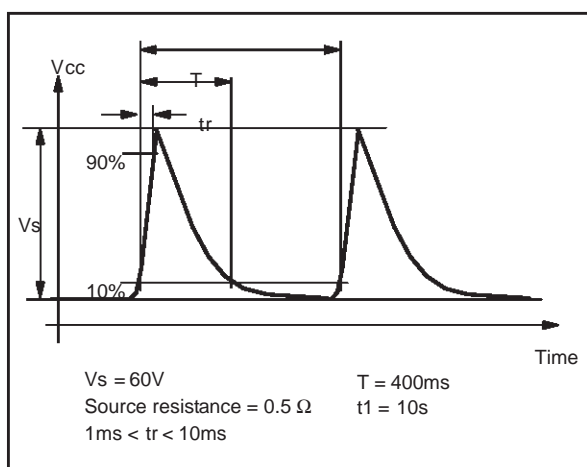
**Figure 3.** L9909 Simplified Application Diagram**Figure 4.** Load Dump Transient**Position Feedback.**

As shown in Figs. 3 and 6, a positive error voltage  $V_{ERR} = V_{COM} - V_{FBK}$  drives the motor with a positive M+ voltage with respect to M-. A correct negative electro-mechanical feedback is established when the motor, supplied with a positive M+ voltage with respect to M-, drives the feedback potentiometer wiper to Vcc.

**Rest Zone.**

When the differential input voltage VERR crosses the zero Volts threshold, as detected by the precision comparator COMP1, the motor is braked by driving it with a zero Volts voltage.

As long as VERR is kept inside the Rest Zone, ranging from -VSTR to +VSTR (see Figs. 1 and 2), no electrical stimulus is applied to the motor terminals. When in the Rest Zone M+ and M- are both driven to Vcc.

**Running Zone.**

When the input error voltage VERR goes out of the Rest Zone (see Figs. 1 and 2) the motor

starts and the wiper voltage VFB of the feedback potentiometer moves in the direction of the input voltage VCOM, bringing the VERR voltage back to zero.

When VERR becomes lower than  $(V_{CC} - V_{STP})/10$ , a proportional control activates. The motor voltage at M+ and M- lowers with a rate factor of 10 times VERR. This motor voltage is generated, according to the motor direction, by connecting to Vcc one motor terminal and by switching the opposite one with a PWM control.

When approaching the target position, at  $V_{ERR}=0$ , the motor jumps into the Rest Zone from a residual VSTP supply voltage. This control

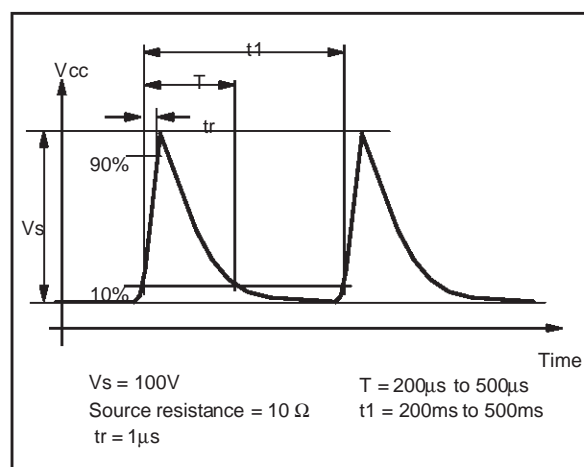
**Figure 5.** Inductive Switching Transient - Positive

is suitable for motors that still run with the min.  $V_{STP}=2.5V$  residual supply voltage in all conditions, ensuring that the rest position is finally reached. But at the same time the max.  $V_{STP}=3.5V$  should not make any motor run too fast and stop far away from the set point for mechanical inertia, or even get out of the rest zone possibly starting oscillations.

**Time Out Counter.**

The Time Out is performed by a 14 Bit Counter that counts 16384 TOSC periods. When the input error voltage VERR goes out of the Rest Zone the motor and the counter start. The motor stops at the VERR zero crossing or when the Counter times out, whichever comes first.

**Direction Control.**

The motor can be driven in both direction and stopped by the timer as shown in Fig. 7.

The bias voltage at VFB input sets the threshold voltage for the direction control input pin (DIR). VFB and VCOM inputs may be swapped causing the motor to reverse directions.

Figure 6. Recommended Application Diagram for Positive Control

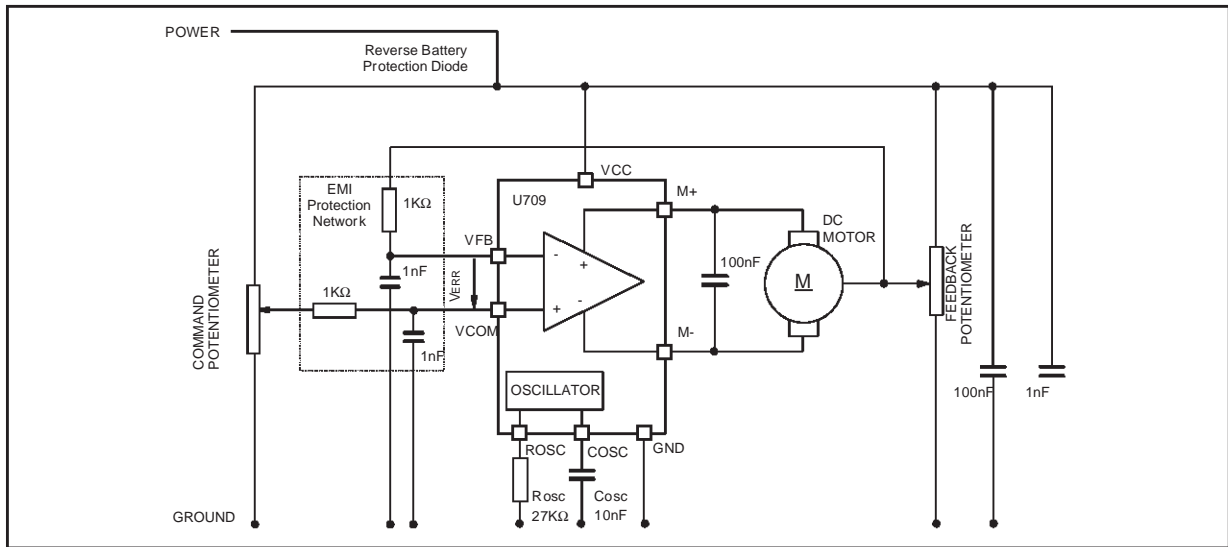
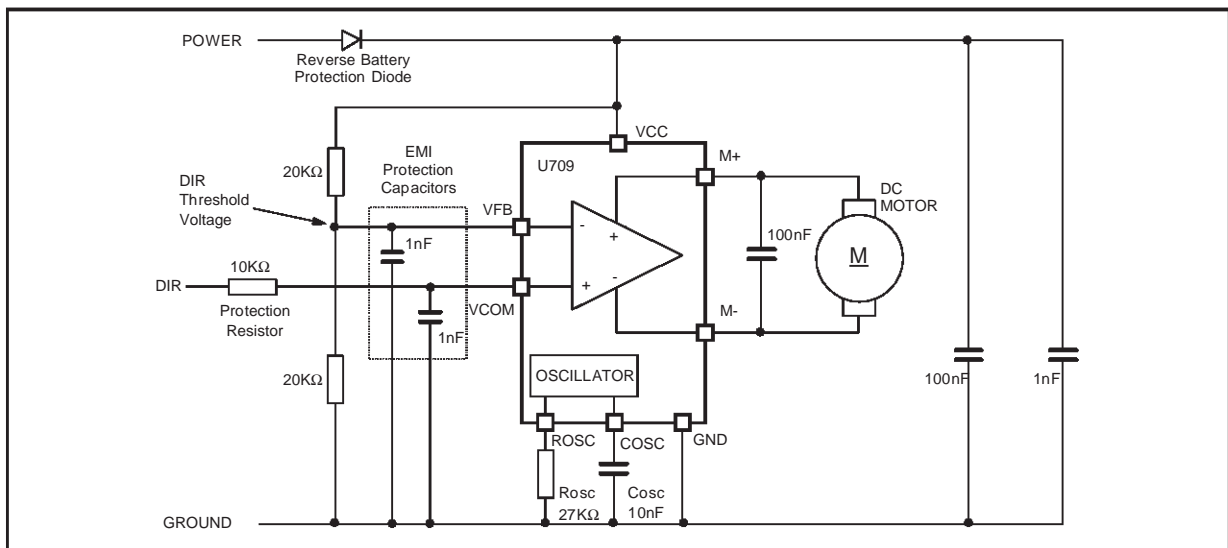

Figure 7. Recommended Application Diagram for Direction Control



**Over Current Protection.**

The driver output pins (M+ and M-) are over current protected by 4 separate linear current limiters, one for each of the 4 power output transistors. The output drivers resume normal operation as soon as the over current is removed.

**Motor Over Voltage Protection.**

The motor is over voltage protected by switching off (to Hi-Z) the M+ and M- output drivers, when Vcc rises above the 19V typ. over voltage shut down threshold.

**Over Temperature Protection.**

The chip is over temperature protected by switching off (to Hi-Z) the M+ and M- output drivers.

**Power Supply Transient Protections.**

The device provides over voltage suppression for fast Vcc voltage transients (Fig. 5). The Vcc is clamped at typ. 70V by turning on all four, bridge connected, power output transistors. They are roughly subjected to equal currents and voltages for even transient energy distribution.

The over voltage suppression is deactivated for slow Vcc voltage transients (Fig. 4) by raising the Vcc voltage clamp at typ. 80V.

The following is the discriminating algorithm between fast and slow Vcc transients. The transient voltage clamp is normally set at 70V. If Vcc rises above the Vcc\_ov=19V typ. over voltage shutdown threshold, both Td\_ov\_1 and Td\_ov\_2 timers start. When the first timer stops (after 130µs typ. delay) the clamp status is evaluated and locked. If the transient has been fast enough and the voltage clamp activated, then it remains 70V active until the second timer stops (after 1ms de-

lay), then it deactivates by rising to 80V. If the transient has been slow and the voltage clamp unreached when the first timer stops, then it deactivates by rising to 80V. A new 70V clamp cycle may restart only by lowering Vcc below the 19V over voltage shutdown threshold.

The VFB and VCOM input pins may connect to the Vcc or lower voltage during the power supply transients of Figs. 4 and 5.

DIM.	mm			inch		
	MIN.	TYP.	MAX.	MIN.	TYP.	MAX.
A		3.32			0.131	
a1	0.51			0.020		
B	1.15		1.65	0.045		0.065
b	0.356		0.55	0.014		0.022
b1	0.204		0.304	0.008		0.012
D			10.92			0.430
E	7.95		9.75	0.313		0.384
e		2.54			0.100	
e3		7.62			0.300	
e4		7.62			0.300	
F			6.6			0.260
l			5.08			0.200
L	3.18		3.81	0.125		0.150
Z			1.52			0.060

**OUTLINE AND MECHANICAL DATA**

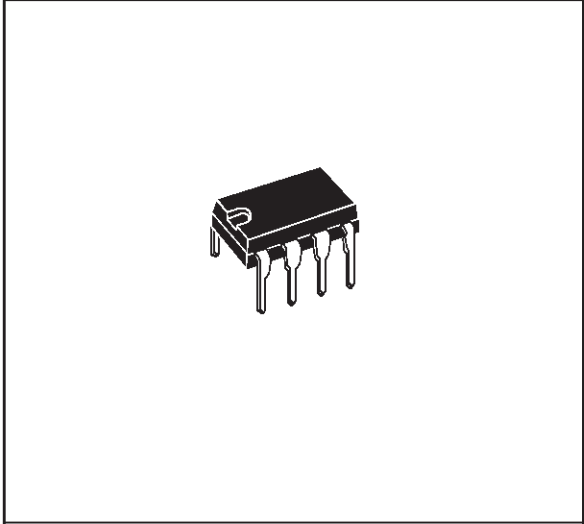

**Minidip**

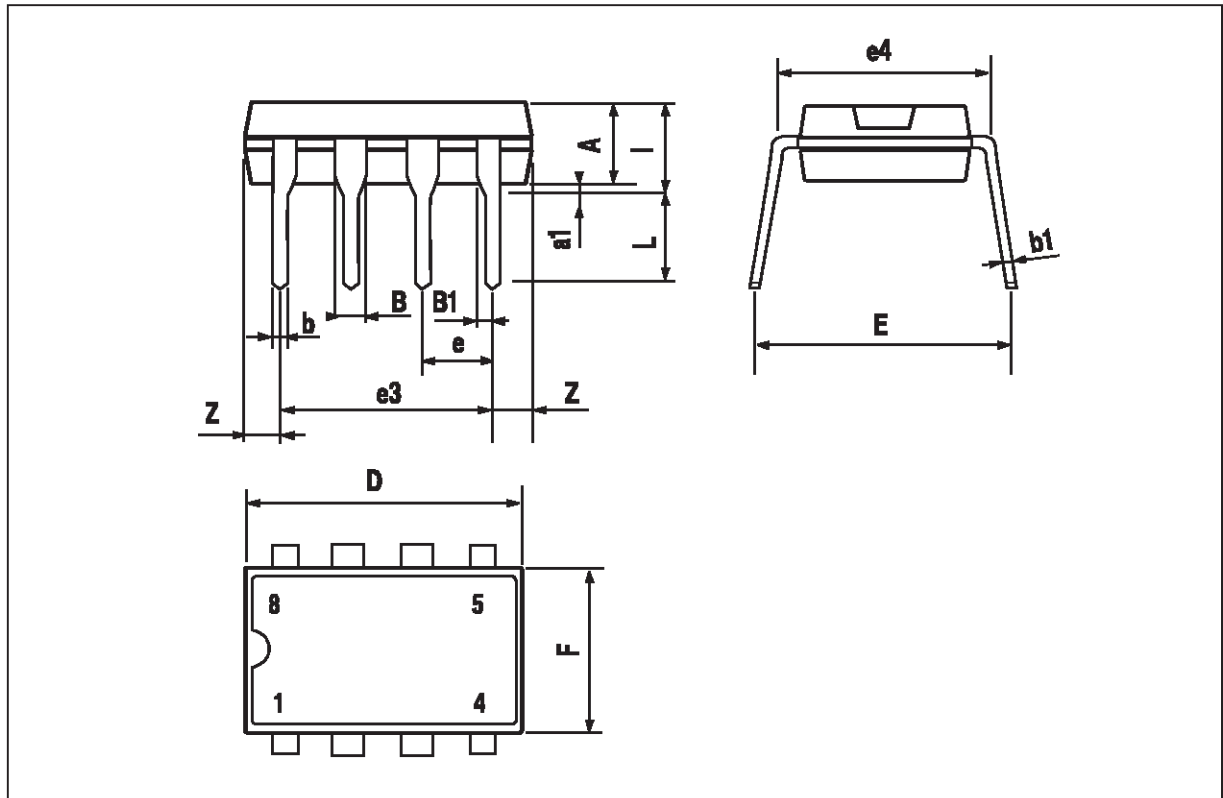



Information furnished is believed to be accurate and reliable. However, STMicroelectronics assumes no responsibility for the consequences of use of such information nor for any infringement of patents or other rights of third parties which may result from its use. No license is granted by implication or otherwise under any patent or patent rights of STMicroelectronics. Specification mentioned in this publication are subject to change without notice. This publication supersedes and replaces all information previously supplied. STMicroelectronics products are not authorized for use as critical components in life support devices or systems without express written approval of STMicroelectronics.

The ST logo is a registered trademark of STMicroelectronics

© 2001 STMicroelectronics – Printed in Italy – All Rights Reserved

STMicroelectronics GROUP OF COMPANIES

Australia - Brazil - China - Finland - France - Germany - Hong Kong - India - Italy - Japan - Malaysia - Malta - Morocco -  
Singapore - Spain - Sweden - Switzerland - United Kingdom - U.S.A.

<http://www.st.com>