

Octal self configuring low/high side driver

Features

- Eight independently self configuring low/high drivers
- Supply voltage from 4.5 V to 5.5 V
- $R_{ON(max)} = 0.7 \Omega @ T_j = 25 \text{ }^\circ\text{C}$,
 $R_{ON(max)} = 1.2 \Omega @ T_j = 125 \text{ }^\circ\text{C}$
- Minimum current limit of each output 1 A
- Output voltage clamping min. 40 V in low-side configuration
- Output voltage clamping max. -14 V in high-side configuration
- SPI interface for outputs control and for diagnosis data communication
- Additional PWM inputs for 3 outputs
- Independent thermal shutdown for all outputs open load, short to GND, short to Vb, overcurrent diagnostics in latched or unlatched mode for each channel
- Internal charge pump without need of external capacitor
- Controlled SR for reduced EMC

Description

The L9733 is a highly flexible monolithic, medium current, output driver that incorporates 8 outputs that can be used as either internal low or high-side drives in any combination.

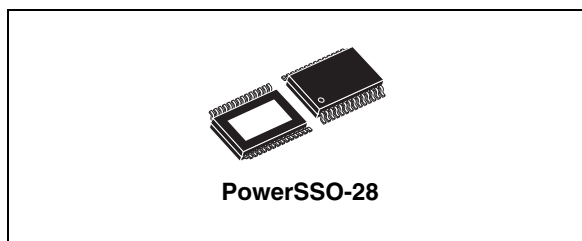

Outputs 1-8 are self-configuring as high or low-side drives. Self-configuration allows a user to connect a high or low-side load to any of these outputs and the L9733 will drive them correctly as well as provide proper fault mode operation with no other needed inputs. In addition, outputs 6, 7 and 8 can be PWM controlled via a external pins (IN6-8).

This device is capable of switching variable load currents over the ambient range of -40 °C to +125 °C. The outputs are MOSFET drivers to minimize Vdd current requirements. For low-side configured outputs an internal zener clamp from the drain to gate with a breakdown of 50 V minimum will provide fast turn off of inductive loads. When a high-side configured output is commanded Off after having been commanded On, the source voltage will go to (VGND - 15 V).

An 16 bit SPI input is used to command the 8 output drivers either "On" or "Off", reducing the I/O port requirement of the microcontroller. Multiple L9733 can be daisy-chained. In addition the SPI output indicates latched fault conditions that may have occurred.

Table 1. Device summary

Order code	Package	Packing
L9733XP	PowerSSO-28 (Exposed pad)	Tube
L9733XPTR	PowerSSO-28 (Exposed pad)	Tape and reel
L9733CN	PowerSSO-28 (Exposed pad)	Tube
L9733CNTR	PowerSSO-28 (Exposed pad)	Tape and reel

Contents

- 1 Pin description 6**
- 2 Operating conditions 8**
 - 2.1 Operating range 8
 - 2.1.1 Functional operative range 8
 - 2.1.2 Jump start conditions 8
 - 2.1.3 Operation at low battery condition 9
 - 2.1.4 Operation at load dump condition 9
 - 2.1.5 Loss of protection against short to battery 9
 - 2.2 Absolute maximum ratings 9
 - 2.3 Thermal data 10
- 3 Electrical performance characteristics 11**
 - 3.1 DC characteristics 11
 - 3.2 AC characteristics 14
 - 3.3 SPI characteristics and timings 16
- 4 Functional description 18**
 - 4.1 Configurations for outputs 1-8 18
 - 4.1.1 Low-side drivers 18
 - 4.1.2 High-side drivers 18
 - 4.2 Outputs 1-5 18
 - 4.3 Outputs 6-8 19
 - 4.4 Drn1-8 susceptibility to negative voltage transients 19
 - 4.5 Supply pins 19
 - 4.5.1 Main power input (Vdd) 19
 - 4.5.2 Battery supply (Vbat) 19
 - 4.5.3 Discrete inputs voltage supply (VDO) 19
 - 4.6 Discrete inputs 20
 - 4.6.1 Output 6-8 enable input (In6, In7, In8) 20
 - 4.6.2 Reset input (RES) 20
- 5 Serial peripheral interface (SPI) 21**

5.1	Serial data output (DO)	21
5.2	Serial data input (DI)	21
5.3	Chip select (CS)	21
5.4	Serial clock (SCLK)	22
5.5	Initial input command register and fault register SPI cycle	22
5.6	Input command register	22
6	Other L9733 features	24
6.1	Charge pump usage	24
6.2	Waveshaping	24
6.3	POR register initialization	24
6.4	Thermal shutdown	24
7	Fault operation	25
7.1	Low-side configured output fault operation	25
7.1.1	No latch mode	25
7.1.2	Latch mode	26
7.2	High-side configured output fault operation	27
7.2.1	No latch mode	27
7.2.2	Latch mode	28
8	Application circuit	31
9	Package information	32
10	Revision history	33

List of tables

Table 1.	Device summary	1
Table 2.	Pin description	6
Table 3.	Operating range	8
Table 4.	Absolute maximum ratings	9
Table 5.	Thermal data	10
Table 6.	DC characteristics	11
Table 7.	AC characteristics	14
Table 8.	SPI characteristics and timings	16
Table 9.	Bit command register definition	22
Table 10.	Command register logic definition	23
Table 11.	Fault register definition	25
Table 12.	Fault logic definition	25
Table 13.	Document revision history	33

List of figures

Figure 1.	Pin connection (top view)	6
Figure 2.	Output turn on/off delays and slew rates	15
Figure 3.	DO loading for disable time measurement	17
Figure 4.	Output loading for slew rate measurements	17
Figure 5.	SPI input/output timings	17
Figure 6.	SPI timing diagram	17
Figure 7.	L9733 application schematic	29
Figure 8.	L9733 HVAC applicative examples	29
Figure 9.	L9733 powertrain applicative examples	30
Figure 10.	Optimized circuit layout to achieve proper EMI/ESD capability	31
Figure 11.	PowerSSO28 mechanical data and package dimensions	32

1 Pin description

Figure 1. Pin connection (top view)

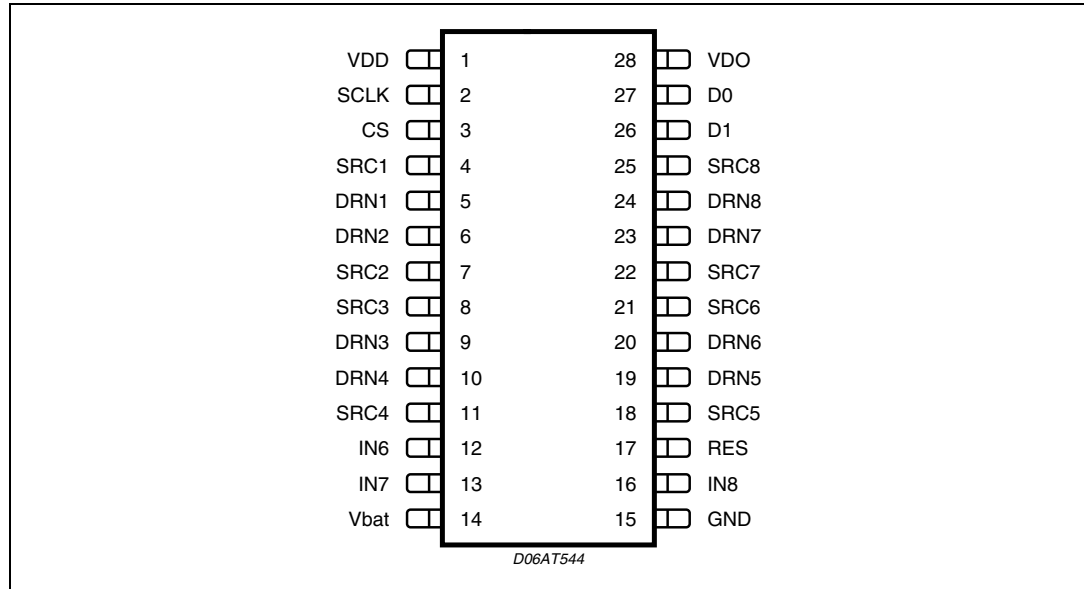

Table 2. Pin description

N°	Pin	Function
1	VDD	5 Volt supply input
2	SCLK	SPI serial clock input
3	CS	SPI chip select (active low)
4	SRC1	Source pin of configurable driver #1 (0.7 Ω Rds _{on} @ +25 °C)
5	DRN1	Drain pin of configurable driver #1 (0.7 Ω Rds _{on} @ +25 °C)
6	DRN2	Drain pin of configurable driver #2 (0.7 Ω Rds _{on} @ +25 °C)
7	SRC2	Source pin of configurable driver #2 (0.7 Ω Rds _{on} @ +25 °C)
8	SRC3	Source pin of configurable driver #3 (0.7 Ω Rds _{on} @ +25 °C)
9	DRN3	Drain pin of configurable driver #3 (0.7 Ω Rds _{on} @ +25 °C)
10	DRN4	Drain pin of configurable driver #4 (0.7 Ω Rds _{on} @ +25 °C)
11	SRC4	Source pin of configurable driver #4 (0.7 Ω Rds _{on} @ +25 °C)
12	IN6	Discrete input used to PWM output driver #6
13	IN7	Discrete input used to PWM output driver #7
14	Vbat	Battery supply voltage
15	GND	Analog ground
16	IN8	Discrete input used to PWM output driver #8
17	RES	Reset input (active low)
18	SRC5	Source pin of configurable driver #5 (0.7 Ω Rds _{on} @ +25 °C)

Table 2. Pin description (continued)

N°	Pin	Function
19	DRN5	Drain pin of configurable driver #5 (0.7 Ω Rds _{on} @ +25 °C)
20	DRN6	Drain pin of configurable driver #6 (0.7 Ω Rds _{on} @ +25 °C)
21	SRC6	Source pin of configurable driver #6 (0.7 Ω Rds _{on} @ +25 °C)
22	SRC7	Source pin of configurable driver #7 (0.7 Ω Rds _{on} @ +25 °C)
23	DRN7	Drain pin of low-side driver #7 (0.7 Ω Rds _{on} @ +25 °C)
24	DRN8	Drain pin of low-side driver #8 (0.7 Ω Rds _{on} @ +25 °C)
25	SRC8	Source pin of configurable driver #8 (0.7 Ω Rds _{on} @ +25 °C)
26	DI	SPI data in
27	DO	SPI data out
28	VDO	Microcontroller logic interface voltage

Note: The exposed slug must be soldered on the PCB and connected to GND.

2 Operating conditions

2.1 Operating range

This part may not operate if taken outside the operating range. Once the condition is returned to within the specified maximum rating or the power is recycled, the part will recover with no damage or degradation.

Table 3. Operating range

Symbol	Parameter	Value	Unit
V _{dd}	Supply voltage	4.5 to 5.5	V
V _{bat} (operative range)	Battery supply voltage	4.5V to 18	V
V _{bat} @ JSC		18 to 27	
V _{bat} @ low battery		3.5 to 4.5	
V _{bat} @ load dump		27 to 40	
T _j	Thermal junction temperature range	-40 to 150	°C
	Snubbing voltage of DRN1-8	min 50	VDC
I _{Ox}	Output current 1-8	max 800	mA
E _{so}	Maximum clamping energy at switch-off	20	mJ

2.1.1 Functional operative range

$$4.5 \text{ V} \leq V_{\text{bat}} \leq 18 \text{ V} \quad (-40 \text{ °C} \leq T_j \leq 150 \text{ °C});$$

All the electrical capabilities are guaranteed by characterization as reported in [Section 3: Electrical performance characteristics](#).

2.1.2 Jump start conditions

$$18 \text{ V} \leq V_{\text{bat}} \leq 27 \text{ V} \quad (-40 \text{ °C} \leq T_j \leq 150 \text{ °C});$$

Operation at Jump start condition for a maximum duration of 1 minute.

All outputs are switched according to the commands on the SPI bus or the PWM inputs. The SPI bus and the inputs are functional during the Jump-Start condition.

The over-temperature shutdown and over current protection of the device is not guaranteed to stay functional for Vbat between 18 V and 27 V.

The reliability and the functionality of the L9733XP are not compromised when the Jump-Start condition is not repeated for more than five times.

2.1.3 Operation at low battery condition

$$3.5 \text{ V} \leq V_{\text{bat}} \leq 4.5 \text{ V} \quad (-40 \text{ }^{\circ}\text{C} \leq T_j \leq 150 \text{ }^{\circ}\text{C});$$

All outputs are able to keep the status in according to the commands on the SPI bus or the PWM inputs. Switching commands entered via the SPI bus might not be executed by the L9733 at low-battery condition. The SPI bus and the inputs are functional during the Low-Battery condition.

2.1.4 Operation at load dump condition

$$27 \text{ V} \leq V_{\text{bat}} \leq 40 \text{ V} \quad (-40 \text{ }^{\circ}\text{C} \leq T_j \leq 150 \text{ }^{\circ}\text{C})$$

There is not an internal circuit that switches OFF the drivers during load dump condition.

The over-temperature shutdown and over current protection of the device is not guaranteed to stay functional during load dump condition.

2.1.5 Loss of protection against short to battery

When the battery supply voltage, V_{bat} (pin 14) is switched off during a short-to-battery condition at a output in high-side configuration, the protection circuits are no longer functional, and the L9733 may fail with EOS.

2.2 Absolute maximum ratings

This part may be irreparably damaged if taken outside the specified absolute maximum ratings. Operation outside the absolute maximum ratings may also cause a decrease in reliability.

Table 4. Absolute maximum ratings

Symbol	Parameter	Value	Unit
V_{DD}	Supply voltage	-0.3 to 7	V
V_{bat}	Supply voltage	-0.3 to 40	V
	CS,DI,DO,SCLK,EN,IN6,IN7,IN8,VDO	-0.3 to 7.0	V
	SRCx pin	min. -24	VDC
	Max. value of $V_{\text{SRCx}} = \text{Minimum of } \{V_{\text{bat}} + 1\text{V} \text{ III } V_{\text{DRNx}} + 0,3 \text{ V III } +40 \text{ V}\}$		
	DRN1-8 ⁽¹⁾	-0.3 to 60	VDC
I_{OL}	Current limit of output 1-8 (-40 °C)	2.5	A
I_{OP}	Over current protection at output 1-8 (-40 °C)	3	A
	Maximum clamping energy	20	mj
ESD	Human body model - All pins	± 2 ⁽²⁾	kV
	Human body model - Driver outputs	± 4 ⁽²⁾	kV

1. For the DRNx the MAX ASB value is the Max Clamp Voltage (see [Table 6](#) on page 13 - DRNx Clamp voltage).

2. Device is only protected vs. GND.

2.3 Thermal data

Table 5. Thermal data

Symbol	Parameter	Min	Typ	Max	Unit
T_{amb}	Operating ambient temperature	-40	-	125	°C
T_{stg}	Storage temperature	-50	-	150	°C
T_j	Maximum operating junction temperature	-	-	150	°C
R_{th}	Thermal shutdown temperature	151	175	200	°C
R_{th-hys}	Thermal shutdown temperature hysteresis	7	10	25	°C
$R_{Th j-amb}$	Thermal resistance junction-to-ambient ⁽¹⁾	-	-	24	°C/W
$R_{Th j-case}$	Thermal resistance junction-to-case	-	-	3	°C/W

1. With 2s2p PCB thermally enhanced.

3 Electrical performance characteristics

These are the electrical capabilities this part was designed to meet. It is required that every part meet these characteristics.

3.1 DC characteristics

$T_{amb} = -40$ to 125 °C, $V_{dd} = 4.5$ to 5.5 Vdc, $V_{bat} = 4.5$ to 18 Vdc (high-side configuration), unless otherwise specified.

Table 6. DC characteristics

Symbol	Parameter	Conditions	Min	Typ	Max	Units
IN6V _{ih}	IN6 input voltage		-	-	0.7vdo	V
IN6V _{il}			0.3vdo	-	-	V
I _{IN6il}	IN6 input current	In6 = 0 VDC	-	-	10	μA
I _{IN6ih}		In6 = VDO	10	-	100	μA
IN7V _{ih}	IN7 input voltage		-	-	0.7vdo	V
IN7V _{il}			0.3vdo	-	-	V
I _{IN7il}	IN7 input current	In7 = 0 VDC	-	-	10	μA
I _{IN7ih}		In7 = VDO	10	-	100	μA
IN8V _{ih}	IN8 input voltage		-	-	0.7vdo	V
IN8V _{il}			0.3vdo	-	-	V
I _{IN8il}	IN8 input current	In8 = 0 VDC	-	-	10	μA
I _{IN8ih}		In8 = VDO	10	-	100	μA
CS _{ih}	CS input voltage		-	-	0.7vdo	V
CS _{il}			0.3vdo	-	-	V
I _{CSih}	CS input current	CS = VDO	-	-	10	μA
I _{CSil}		CS = 0 VDC	10	-	100	μA
SCLK _{ih}	SCLK input voltage		-	-	0.7vdo	V
SCLK _{il}			0.3vdo	-	-	V
I _{SCLKih}	SCLK input current	SCLK = VDO	-	-	10	μA
I _{SCLKil}		SCLK = 0 VDC	10	-	100	μA
DI _{ih}	DI input voltage		-	-	0.7vdo	V
DI _{il}			0.3vdo	-	-	V
I _{DIih}	DI input current	DI = VDO	-	-	10	μA
I _{DIil}		DI = 0 VDC	10	-	100	μA
DO _{ol}	DO output voltages	I _{DO} = 2.5 mA	-	-	0.4	V
DO _{oh}		I _{DO} = -2.5 mA	vdo-0.6	-	-	V

Table 6. DC characteristics (continued)

Symbol	Parameter	Conditions	Min	Typ	Max	Units
I_{DOz0l}	DO Tri-state currents	DO = 0 VDC	-	-	10	μA
I_{DOz0h}		DO = VDO	-	-	10	μA
RES_{Ih}	RES input voltage		-	-	0.7vdo	V
RES_{Il}			0.3vdo	-	-	V
I_{RESil}	RES input current	RES = 0 VDC	10	-	100	μA
I_{RESih}		RES = VDO	-	-	10	μA
POR_{th}	Power on reset threshold	@ -40 °C	2.8	-	4.2	V
		@ 25 °C	2.8	-	3.7	
		@ 125 °C	2	-	3.4	
I_{slp}	Vbat sleep current	VDD = SRC1-8 = 0VDC DRN1-DRN8=18VDC, Vb. Sum currents ($T_{amb} > 0\text{ }^{\circ}C$)	-	-	10	μA
		($T_{amb} @ -40\text{ }^{\circ}C$)			3	μA
I_{vbat}	Vbat current	VDD = 5 V All Outputs Commanded On	-	-	15	mA
I_{VDD}	Max. VDD current	All Outputs Commanded On	-	-	8.5	mA
I_{VDD}	Min. VDD current	All Outputs Commanded Off	0.5	-		mA
$I_{DRN1Ik} - I_{DRN8Ik}$	DRN1 - DRN8 leakage currents (low-side)	VDD = 0 VDC: SRC1-8 = 0 VDC	-	-	5	μA
		DRN1- DRN8 = 16 VDC DRN1- DRN8 = 40 VDC			10	μA
$I_{SRC1Ik} - I_{SRC8Ik}$	SRC1 – SRC8 Leakage currents (high-side)	VDD = 0 VDC: SRC1-8 = 0 VDC	-	-	-5	μA
		DRN1- 8 = 16 V DRN1- 8 = 40 VDC			-10	μA
$I_{Drn1-8sink}$	DRN1 – DRN8 sink current (low-side)	SRC1-8 = GND DI = AC00h	10	-	100	μA
		$R_{load} \leq 11\text{ k}\Omega$ $R_{load} \leq 200\text{ k}\Omega$	120		280	μA
R_{DRN1-8}	Open load detection resistance	VBAT \geq 9V	11	-	200	K Ω
$I_{Drn1-8source}$	Source current	DRN1-DRN8 = GND	-10	-	-100	μA
$I_{src1-8sink}$	SRC1 – SRC8 sink/source current (high-side)	DRN1- 8 = Vb, DI = AC00h SCR1- 8 = Vb	10	-	100	μA
		SCR1- 8 = GND	-18	-	-100	μA
$V_{Drn1-8open}$	DRN1 – DRN8 open load voltage (low-side)	SRC1- 8 = GND, DI = AC00h DRN1- DRN8 = Open VDD=4.9 to 5.1 VDC	2.7	-	3.1	V
		SRC1- 8 = GND, DI = AC00h DRN1- DRN8 = Open VDD = 4.5 to 5.5 V	2.5	-	3.5	V

Table 6. DC characteristics (continued)

Symbol	Parameter	Conditions	Min	Typ	Max	Units
$V_{src1-8open}$	SRC1 – SRC8 open load voltage (High-side) DRN1 - DRN8	DRN1-8 = Vb, DI = AC00h SCR1-8 = open	2.0	-	2.8	V
$I_{DRN1limit}^-$ $I_{DRN8limit}^-$	DRN1 - DRN8 current limits (low-side)	DI = ACFFh, DI = AAFFh SRC1 – SRC8 = 0 VDC DRN1 - DRN8 = 4.5 - 16 VDC ($T_{amb} > 0\text{ }^{\circ}\text{C}$) ($T_{amb} @ -40\text{ }^{\circ}\text{C}$)	1 1	-	2.2 2.5	A A
$I_{DRN1OVC}^-$ $I_{DRN8OVC}^-$	DRN1 - DRN8 overcurrent threshold (low-side)	DI = AC00h, DI = AA00h SRC1 – SRC8 = 0 VDC DRN1 - DRN8 = 4.5 - 16 VDC ($T_{amb} > 0\text{ }^{\circ}\text{C}$) ($T_{amb} - 40\text{ }^{\circ}\text{C}$)	1 1	-	2.7 3	A A
$I_{SRC1limit}^+$ $I_{SRC8limit}^+$	SRC1 – SRC8 current limits (high-side)	DI = ACFFh, DI = AAFFh DRN1 - DRN8 = Vb SRC1 – SRC8 = GND ($T_{amb} > 0\text{ }^{\circ}\text{C}$) ($T_{amb} - 40\text{ }^{\circ}\text{C}$)	1 1	-	2.2 2.5	A A
$I_{SRC1OVC}^+$ $I_{SRC8OVC}^+$	Overcurrent threshold (high-side)	DRN1 - DRN8 = Vbat SRC1 – SRC8 = GND ($T_{amb} > 0\text{ }^{\circ}\text{C}$) ($T_{amb} - 40\text{ }^{\circ}\text{C}$)	1 1	-	2.7 3	A A
$DRN1_{Cl+}$ - $DRN8_{Cl+}$	DRN1 - DRN8 Clamp voltages (low-side)	DI = AC00h SRC1-8 = GND, $I_{DRN1-8} = 350\text{ mA}$	50	-	60	V
$SRC1_{Cl-}$ - $SRC8_{Cl+}$	SRC1 – SRC8 Clamp voltages (High-side)	DI = AC00h DRN1-8 = Vbat, $I_{SRC1-8} = -350\text{ mA}$	-24	-	-14	V
$V_{Drn1-8open}$ - δ_{VthGND}	Short to GND threshold distance from open load voltage (low-side)	SRC1 – SRC8 = GND: Decrease Drn1 - Drn8 until Faults are "Set"	0.3	-	0.7	V
$DRN1-$ $\delta_{VthVbat}^-$ $V_{Drn1-8open}$	DRN1 - DRN8 Short to Vbat threshold distance from open load voltage (low-side)	DI = AC00h SRC1 – SRC8 = GND: Increase Drn1 - Drn8 until Faults are "Not Set"	0.3	-	0.7	V
$V_{Drn1-8open}$ - $SRC1-$ δ_{VthGND}	SRC1 - SRC8 Short to GND threshold distance from open load voltage (High-side)	DI = AC00h Drn1 – Drn8 = Vb: Decrease SRC1 - SRC8 until Faults are "Not Set"	0.2	-	0.6	V
$SRC1-$ $\delta_{VthVbat}^-$ $V_{Drn1-8open}$	SRC1 – SRC8 Short to Vbat threshold distance from open load voltage (High-side)	DI = AC00h Drn1 – Drn8 = Vbat: Increase SCR1 - SCR8 until Faults are "Set"	0.2	-	0.6	V

Table 6. DC characteristics (continued)

Symbol	Parameter	Conditions	Min	Typ	Max	Units
R _{dsonDrn1-8} ⁽¹⁾	On resistance (Drn to SRC1-8)	@ +125 °C @ I _{DRN} = 350 mA	-	-	1.2	Ω
		@ +25 °C @ I _{DRN} = 350 mA	-	-	0.7	Ω
		@ -40 °C @ I _{DRN} = 350 mA		-	0.5	Ω
Drn1-8 _{ther} ⁽²⁾	Thermal shutdown temperature	DI = ACFFh, I _{Drn1-8} = 1 mA, SRC1 – SRC8 = GND, Increase temperature until Drn1 - Drn8 > 2 VDC, Verify DO Bits 0-15 are "Set"	151	-	200	°C
Drn1-8 _{hyst} ⁽²⁾	Hysteresis	Drn1 - Drn8 < 2 VDC	5	-	15	°C

1. R_{dsonDrn1-8} ≤ 1.2 Ω; at V_{bat} between 3.5 V and 27 V and T between -40 °C and 150 °C

2. Design Information, not tested.

3.2 AC characteristics

T_{amb} = -40 to 125 °C, V_{dd} = 4.5 to 5.5 Vdc, V_{bat} = 4.5 to 18 Vdc, unless otherwise specified

Table 7. AC characteristics

Symbol	Parameter	Conditions	Min	Typ	Max	Units
T _{filtDRN1-8}	DRN1 - DRN8 Open load & short to GND filter time (low-side) (Latch mode)	DI = AC00h, DI = A3FFh SRC1 – SRC8 = GND	300	-	900	μs
T _{filtSRC1-8}	SRC1 - SRC8 Open load & short to Vbat filter time (high-side) (Latch mode)	DI = AC00h, DI = A3FFh DRN1 – DRN8 = Vb	300	-	900	μs
T _{delDRN1-8}	DRN1 - DRN8 Overcurrent switch off delay (low-side)	DI = ACFFh, DI = AA00h SRC1 – SRC8 = GND	10	-	75	μs
T _{delSRC1-8}	SRC1 - SRC8 Overcurrent switch off delay (high-side)	DI = ACFFh, DI = AA00h DRN1 – DRN8 = Vb	10	-	75	μs
T _{res}	Restart time after overcurrent switch off time (Int)	DI = ACFFh, DI = AA00h	120	-	450	ms
Drn1-8 _{htol}	Slew rate turn on	Outputs loaded as Figure 4 See Figure 2	0.65	-	1.95	V/μs
Drn1-8 _{itoh}	Turn off (low-side)	See Figure 2	0.5	-	1.5	V/μs

Table 7. AC characteristics (continued)

Symbol	Parameter	Conditions	Min	Typ	Max	Units
SRC1-8 _{htol}	Slew rate turn on	Outputs loaded as <i>Figure 4</i> See <i>Figure 2</i>	0.65	-	1.95	V/μs
SRC1-8 _{ltoh}	Turn off (High-side)		0.5	-	1.5	V/μs
Drn1-8 _{tondly}	Delay time Turn on	Outputs loaded as <i>Figure 4</i> See <i>Figure 2</i>	2	-	20	μs
Drn1-8 _{toffdly}	Turn off (low-side)		10	-	100	μs
SRC1-8 _{tondly}	Delay time Turn on	Outputs loaded as <i>Figure 4</i> See <i>Figure 2</i>	2	-	20	μs
SRC1-8 _{toffdly}	Turn off (high-side)		10	-	100	μs
Drn1-8 _{offon}	Delay delta	Drn1-8 _{toffdly} - Drn1-8 _{tondly}	10	-	60	μs
SRC1-8 _{offon}	Delay delta	SRC1-8 _{toffdly} - SRC1-8 _{tondly}	10	-	60	μs

Figure 2. Output turn on/off delays and slew rates

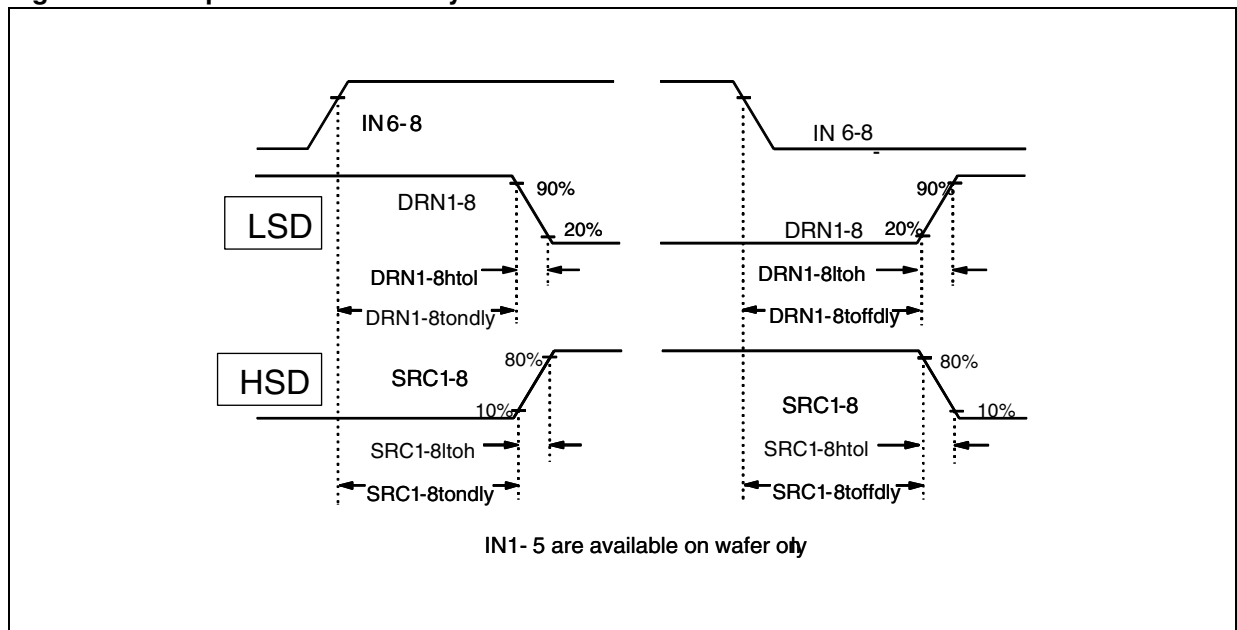

3.3 SPI characteristics and timings

$T_{amb} = -40$ to 125 °C, $V_{dd} = 4.5$ to 5.5 Vdc, $V_{bat} = 4.5$ to 18 Vdc, unless otherwise specified

Table 8. SPI characteristics and timings

Symbol	Parameter	Conditions	Min	Typ	Max	Units
DINC _{in}	Input capacitance		-	-	20	pF
SCLK _{Cin}			-	-	20	pF
DO _{rise}	Output data (do) rise time	50 pF from DO to Ground See Figure 5	-	-	70	ns
DO _{fall}	Output data (do) fall time	See Figure 5	-	-	70	ns
DO _a	Access time	See Figure 6	-	-	350	ns
DO _{sum}	Set up time	See Figure 6	20	-	-	ns
DO _{hm}	Hold time	See Figure 6	10	-	-	ns
DO _{dis}	Output data (DO) disable time	No Capacitor on DO, See Figure 5	-	-	400	ns
tth _{Filt}	Filter time	All Fault bits are "Set"	5	-	20	μs
SCLK _{wid}	SCLK width	See Figure 5 , @ f _{SCLK} = 5.4MHz ⁽¹⁾	185	-	-	ns
SCLK _{lm}	SCLK low time	See Figure 5 , @ f _{SCLK} = 5.4MHz ⁽¹⁾	58	-	-	ns
SCLK _{hm}	SCLK high time	See Figure 5 , @ f _{SCLK} = 5.4MHz ⁽¹⁾	58	-	-	ns
SCLK _{rise}	SCLK rise time	See Figure 5 , @ f _{SCLK} = 5.4MHz ⁽¹⁾	-	-	21	ns
SCLK _{fall}	SCLK fall time	See Figure 5 , @ f _{SCLK} = 5.4MHz ⁽¹⁾	-	-	21	ns
CS _{rise}	Channel select (CS) rise time	See Figure 5 ⁽¹⁾	-	-	100	ns
CS _{fall}	Channel select (CS) fall time	See Figure 5 ⁽¹⁾	-	-	100	ns
CS _{lead}	Channel select (CS) lead time	See Figure 6 ⁽¹⁾	455	-	-	ns
CS _{lag}	Channel select (CS) lag time	See Figure 6 ⁽¹⁾	50	-	-	ns
DI _{rise}	Input data (DI) rise time	See Figure 5 , @ f _{SCLK} = 5.4MHz ⁽¹⁾	-	-	30	ns
DI _{fall}	Input data (DI) fall time	See Figure 5 @ f _{SCLK} = 5.4MHz ⁽¹⁾	-	-	30	ns
DI _{sus}	Input data (DI) set-up time	See Figure 6 , @ f _{SCLK} = 5.4MHz ⁽¹⁾	15	-	-	ns
DI _{hs}	Input data (DI) hold time	See Figure 6 , @ f _{SCLK} = 5.4MHz ⁽¹⁾	10	-	-	ns
CS2SCLK	CS rise to SCLK rise	See Figure 6 , @ f _{SCLK} = 5.4MHz ⁽¹⁾	40	-	300	ns

1. Guaranteed by design.

Figure 3. DO loading for disable time measurement

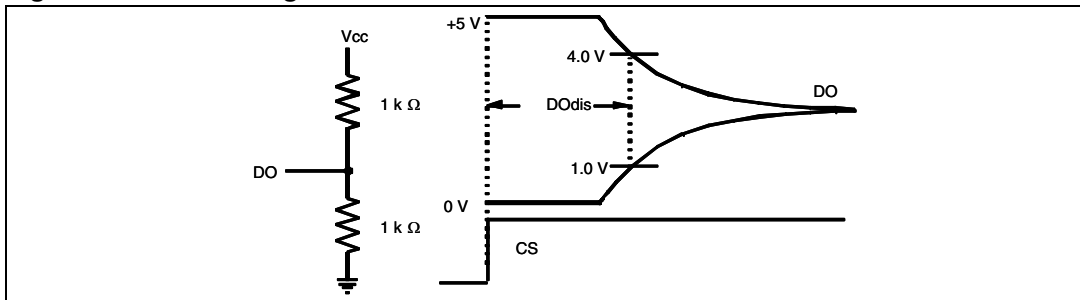

Figure 4. Output loading for slew rate measurements

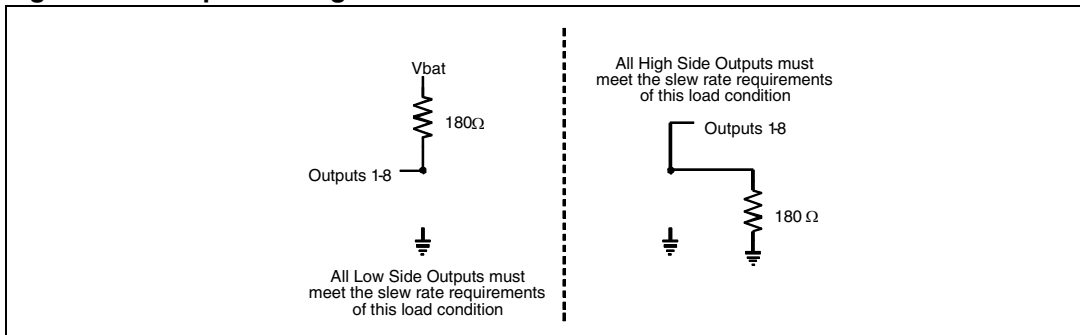

Figure 5. SPI input/output timings

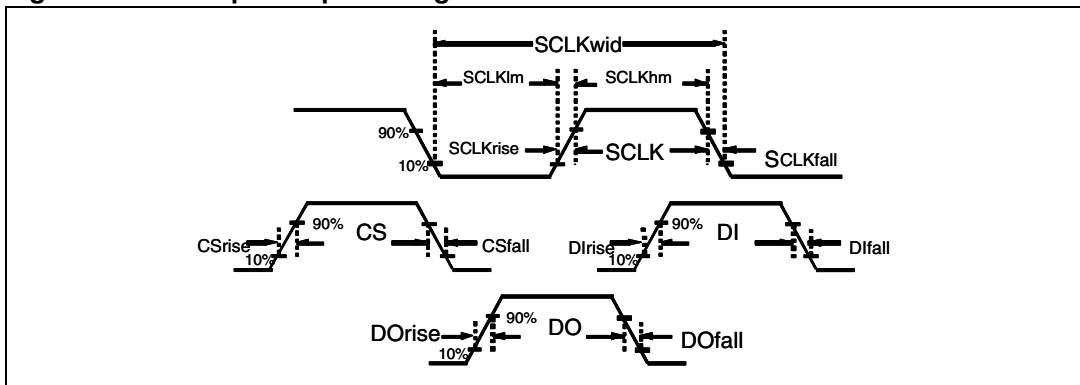
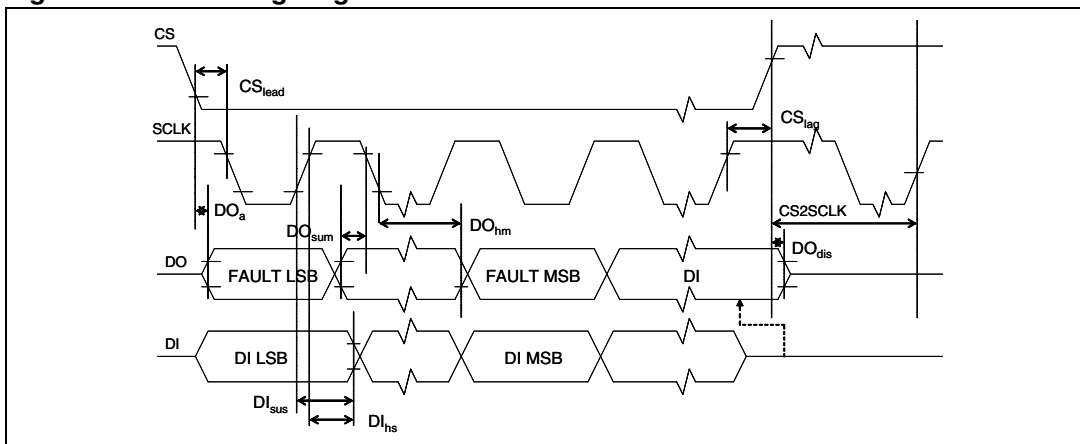

Figure 6. SPI timing diagram



4 Functional description

L9733 integrates 8 self-configuring outputs (OUT1-8) which are able to drive either incandescent lamps, inductive loads (non-pwm'd, in pwm is necessary an external diode to reduce flyback power dissipation), or resistive loads biased to Vbat (low-side configuration) or to GND (high-side configuration). These outputs can be enabled and disabled via the SPI bus. Each of these outputs has a short circuit protection (with 0.8-2.4 Amps threshold) selectable via SPI bus between a filtered switching OFF overcurrent protection or a linear current limitation (default condition after power ON is switching OFF protection enabled).

An over-temperature protection as described in [Section 2.1](#) is available for each outputs. When a high-side configured output is commanded OFF after having been commanded ON, the source voltage will go to (VGND - 15 V). This is due to the design of the circuitry and the transconductance of the MOSFET. When a low-side configured output is commanded OFF after having been commanded ON, the output voltage will rise to the internal zener clamp voltage (50 VDC minimum) due to the flyback of the inductive load.

Outputs 1-8 are able to drive any combination of inductive loads or lamps at one time. Inductive loads for the L9733 can range from 35mH to a maximum of 325 mH. The recommended worst-case solenoid loads (at -40 °C) are calculated using a minimum resistance of 40Ω for each output. The maximum single pulse inductive load energy the L9733 outputs is able to be safely handle is 20 mJ at -40 °C to 125 °C (Worst-case load of 325 mH and 40 Ω).

4.1 Configurations for outputs 1-8

The drain and source pins for each output must be connected in one of the two following configurations (see [Figure 7](#)).

4.1.1 Low-side drivers

When any combination of outputs 1-8 are connected in a low-side drive configuration the source of the applicable output (Src1-8) shall be connected to ground. The drain of the applicable output (Drn1-8) shall be connected to the low-side of the load.

4.1.2 High-side drivers

When any combination of outputs 1-8 are connected in a high-side drive configuration the Drain of the applicable output (Drn1-8) shall be connected to Vbat. The source of the applicable output (Src1-8) shall be connected to the high-side of the load.

4.2 Outputs 1-5

These five outputs can be used as either high or low-side drives. The room temperature R_{dson} of these outputs is 0.7 Ω. A current limited (100 μA max) voltage generator is connected to Src 1-5 for open load and short to GND detection when a low-side configured output is commanded OFF. Another current limited (100 μA max if V_{Drn} 1-5 > 60 % Vbat, 280 μA max if V_{Drn} 1-5 < 60 % Vbat) voltage generator is connected to Drn 1-5 for open load and short to V bat detection when a high-side configured output is commanded OFF. Drain pins of outputs 1-5 (Drn1-5) are connected to the drains of the N channel MOSFET

transistors. Source pins of outputs 1-5 (Src1-5) are connected to the sources of the N-channel MOSFET transistors.

4.3 Outputs 6-8

These three self-configuring outputs can be used to drive either high or low-side loads. In addition to being controlled by the SPI BUS these outputs can also be enabled and disabled via the IN6 & IN7 & IN8 inputs. The IN6, IN7 and IN8 inputs are logically or'd with the SPI commands to allow either the IN6 & IN7 & IN8 inputs or the SPI commands to activate these outputs. The use of the IN6 & IN7 & IN8 pins for PWM control on these outputs should only be done with non-inductive loads if an external flyback diode is not present. The room temperature R_{dson} of these four outputs is 0.7Ω . A current limited ($100\mu\text{A}$ max) voltage generator is connected to Src 6-8 for open load and short to GND detection when a low-side configured output is commanded OFF. Another current limited ($100\mu\text{A}$ max if $V_{Drn\ 6-8} > 60\%V_{bat}$, $280 \mu\text{A}$ max if $V_{Drn\ 6-8} < 60\%V_{bat}$) voltage generator is connected to Drn 6-8 for open load and short to Vbat detection when a high-side configured output is commanded OFF.

Drain pins of Outputs 6-8 (Drn6-8) are connected to the drains of the N channel MOSFET transistors. Source pins of Outputs 6-8 (Src6-8) are connected to the sources of the N channel MOSFET transistors.

4.4 Drn1-8 susceptibility to negative voltage transients

All outputs connected in the low-side configuration must have a ceramic chip capacitor of $0.01\mu\text{F}$ to $0.1 \mu\text{F}$ connected from drain to ground. This is needed to prevent potential problems with the device operation due to the presence of fast negative transient(s) on the drain(s) of the device. Adequate de-coupling capacitors from the Drain (VBAT) to ground shall be provided for high-side configured outputs.

4.5 Supply pins

4.5.1 Main power input (Vdd)

An external $+5.0 \pm 0.5$ VDC supply provided from an external source is the primary power source to the L9733. This supply is used as the power source for all of its internal logic circuitry and other miscellaneous functions.

4.5.2 Battery supply (Vbat)

This input is the supply for the on board charge pump. This input shall be connected directly to battery. If this input is not connected to the same supply, without additional voltage drops, of the drains of any high-side connected outputs, then the R_{dson} of that given output will be higher than the specified maximum.

4.5.3 Discrete inputs voltage supply (VDO)

This pin is used to supply the discrete input stages of L9733 and must be connected to the same voltage used to supply the peripherals of the processor interfaced to L9733.

4.6 Discrete inputs

4.6.1 Output 6-8 enable input (In6, In7, In8)

This input allows Output 6 (or Output 7, or Output 8) to be enabled via this external pin without the use of the SPI. The SPI command and the In6-7 input are logically or'd together. A logic "1" on this input (In6, In7 or In8) will enable this output no matter what the status of the SPI command register. A logic "0" on this input will disable this output if the SPI command register is not commanding this output on. This pins (In6, In7 or In8) can be left "open" if the internal output device is being controlled only via the SPI. This input has a nominal 100k Ω resistor connected from this pin to ground, which will pull this pin to ground if an open circuit condition occur. This input is ideally suited for non-inductive loads that are pulse width modulated (PWM'd). This allows PWM control without the use of the SPI inputs.

4.6.2 Reset input (RES)

When this input goes low it resets all the internal registers and switches off all the output stages. This input has a nominal 100 k Ω resistor connected from this pin to VDD, which will pull this pin to VDD if an open circuit condition occur.

5 Serial peripheral interface (SPI)

The L9733 has a serial peripheral interface consisting of Serial Clock (SCLK), Data Out (DO), Data In (DI), and Chip Select (CS). All outputs will be controlled via the SPI. The input pins CS, SCLK, and DI, thanks to VDO pin, have level input voltages allowing proper operation from microcontrollers that are using 5.0 or 3.3 volts for their Vdd supply. The design of the L9733 allows a "daisy-chaining" of multiple L9733's to further reduce the need for controller pins.

5.1 Serial data output (DO)

This output pin is in a tri-state condition when CS is a logic '1'. When CS is a logic '0', this pin transmits 16 bits of data from the fault register to the digital controller. After the first 16 bits of DO fault data are transmitted (after a CS transition from a logic '1' to a logic '0'), then the DO output sequentially transmits the digital data that was just received (16 SCLK cycles earlier) on the DI pin. The DO output continues to transmit the 16 SCLK delayed bit data from the DI input until CS eventually transitions from a logic '0' to a logic '1'. DO data changes state 10 nsec or later, after the falling edge of SCLK. The LSB is the first bit of the byte transmitted on DO and the MSB is the last bit of the byte transmitted on DO, once CS transitions from a logic '1' to a logic '0'.

5.2 Serial data input (DI)

This input takes data from the digital controller while CS is low. The L9733 accepts an 16 bit byte to command the outputs on or off. The L9733 also serially wraps around the DI input bits to the DO output after the DO output transmits its 16 fault flag bits. The LSB is the first bit of each byte received on DI and the MSB is the last bit of each byte received on DI, once CS transitions from a logic '1' to a logic '0'. The last 4 bits (b15-b12) of the first 16 bit byte are used as key-word. The 4 bits (b11-b8) of the first 16 bits byte are used to select writing mode between OUT8-1 status and diagnosis operating mode . The DI input has a nominal 100 k Ω resistor connected from this pin to the VDO pin, which pulls this pin to VDO if an open circuit condition occurs.

5.3 Chip select (CS)

This is the chip select input pin. On the falling edge of CS, the DO pin is released from tri-state mode. While CS is low, register data are shifted in and shifted out the DI pin and DO pin, respectively, on each subsequent SCLK. On the rising edge of CS, the DO pin is tri-stated and the fault register is "Cleared" if a valid DI byte has been received. A valid DI byte is defined as such:

- a multiple of 16 bits was received.
- a valid key-word was received

The fault data is not cleared unless all of the 2 previous conditions have been met. The CS input has a nominal 100 k Ω resistor connected from this pin to the VDO pin, which pulls this pin to VDO if an open circuit condition occurs.

5.4 Serial clock (SCLK)

This is the clock signal input for synchronization of serial data transfer. DI data is shifted into the DI input on the rising edge of SCLK and DO data changes on the falling edge of SCLK. The SCLK input has a nominal 100kΩ resistor connected from this pin to the VDO pin, which pulls this pin to VDO if an open circuit condition occurs.

5.5 Initial input command register and fault register SPI cycle

After initial application of Vdd to the L9733, the input command register and the fault register are "Cleared" by the POR circuitry and that means that the default condition for the output status is Off, the default diagnostic mode is No Latch and the switching OFF overcurrent protection is enable. During the initial SPI cycle, and all subsequent cycles, valid fault data will be clocked out of DO (fault bits).

5.6 Input command register

An input byte (16 bits) is routed to the Command Register. The content of this Command Register is given in table 9. Additional DI data will continue to be wrapped around to the DO pin. If CS should happen to go high before complete reception of the current byte, this just transmitted byte shall be ignored (invalid).

Table 9. Bit command register definition

Key word				Writing mode: output				Output status							
MSB								LSB							
1	0	1	0	1	1	0	0	OUT 8	OUT 7	OUT 6	OUT 5	OUT 4	OUT 3	OUT 2	OUT 1
b15	b14	b13	b12	b11	b10	b9	b8	b7	b6	b5	b4	b3	b2	b1	b0

Key word				Writing mode: diag				Driver diag mode							
MSB								LSB							
1	0	1	0	0	0	1	1	Diag 8	Diag 7	Diag 6	Diag 5	Diag 4	Diag 3	Diag 2	Diag 1
b15	b14	b13	b12	b11	b10	b9	b8	b7	b6	b5	b4	b3	b2	b1	b0

Key word				Writing mode: protect				Driver overcurrent protection							
MSB								LSB							
1	0	1	0	1	0	1	0	Ilim 8	Ilim 7	Ilim 6	Ilim 5	Ilim 4	Ilim 3	Ilim 2	Ilim 1
b15	b14	b13	b12	b11	b10	b9	b8	b7	b6	b5	b4	b3	b2	b1	b0



Table 10. Command register logic definition

Bit	State	Status	Writing mode
b0-b7	0	OUT1 - OUT8 are commanded off	Output
b0-b7	1	OUT1 - OUT8 are commanded on	Output
b0-b7	0	OUT1 - OUT8 diagnostic is No Latch Mode	Diag
b0-b7	1	OUT1 - OUT8 diagnostic is Latch Mode	Diag
b0-b7	0	OUT1 - OUT8 switching OFF overcurrent protection	Protection
b0-b7	1	OUT1 - OUT8 linear overcurrent protection	Protection

6 Other L9733 features

6.1 Charge pump usage

In order to provide low R_{dson} values when connected in a high-side configuration, a charge pump to drive the internal gate voltage(s) above V_{bat} is implemented. The charge pump used on the L9733 doesn't need external capacitor. The L9733 uses a common charge pump and oscillator for all the 8 configurable output channels. The charge pump uses the V_{bat} supply connected directly to the V_b pin. The normal range of the V_{bat} voltage is 10 to 18V. However, the L9733 is functional with V_{bat} voltages as low as 4.5V DC with eventually a degradation of R_{dson} .

The frequency range of this charge pump is from 3.6 to 7.6 MHz. The frequency is above 1.8 MHz in order to be above the AM radio band and below 8.0 MHz so that harmonics do not get within the FM radio band.

6.2 Waveshaping

Both the turn on and the turn off slew rates on all outputs (OUT1-8) are limited to between 10 μ s and 100 μ s for both rise and fall times (10 to 90 %, and vice versa), to reduce conducted EMC energy in the vehicle's wiring harness. The characteristics of the turn-on and turn-off voltage is linear, with no discontinuities, during the output driver state transition.

6.3 POR register initialization

When the L9733 wakes up, the V_{dd} supply to the L9733 is allowed from 0 to 5 VDC in 0.3 to 3ms. The L9733 has a POR circuit, which monitors the V_{dd} voltage. When the V_{dd} voltage reaches an internal threshold, and remains above this trip level for at least 5 to 20 μ s, the Command and Fault registers are "cleared". Before V_{dd} reaches this trip level, none of the eight outputs are allowed to momentarily glitch on.

6.4 Thermal shutdown

Each of the eight outputs has independent thermal protection circuitry that disables each output driver once the local N-Channel MOSFET's device temperature reaches between +151 and +200 °C. A filter is present to validate the thermal fault (5 μ s to 20 μ s). There is a 5 to 15 °C hysteresis between the enable and disable temperature levels. The faulted channel will periodically turn off and on until the fault condition is cleared, the ambient temperature is decreased sufficiently or the output is commanded off. If a thermal shutdown, of one or more output drivers, is active during the falling edge of the chip select (CS) signal all the bits of the Fault Register are "setted" to "1" (thermal shutdown is not latched and could be read only in the moment it is present). The thermal fault is cleared on the rising edge of Chip Select if a valid DI byte was received.

Note: Due to the design of the L9733 each output's thermal limit "may not" be truly independent to the extent that if one output is shorted, it may impact the operation of other outputs (due to lateral heating in the die).

7 Fault operation

The fault diagnostic capability consists of one internal 16 bits shift register and 2 bits are used for each output. The diagnostic information are: no fault present, overcurrent, open load and short circuit.

For L9733XP all of the faults will be cleared on the rising edge of chip select if a valid DI byte was received.

For L9733CN The OVC register will be cleared after the end of the diagnosis restart time T_{res} or by the input signal (IN) in low state. The other faults will be cleared on the rising edge of chip select if a valid DI byte was received.

Table 11. Fault register definition

OUT 8		OUT 7		OUT6		OUT5		OUT4		OUT3		OUT2		OUT1	
MSB														LSB	
D1	D0	D1	D0	D1	D0	D1	D0	D1	D0	D1	D0	D1	D0	D1	D0
b15	b14	b13	b12	b11	b10	b9	b8	b7	b6	b5	b4	b3	b2	b1	b0

Table 12. Fault logic definition

D1	D0	Fault status
0	0	No fault is present
0	1	Open load
1	0	Short circuit to GND (low-side) or short circuit to Vbat (high-side)
1	1	Overcurrent

If all the bits b0-b15 of the fault register have value '1' it means that a thermal fault, at least on one of the eight independent Outputs, occurred.

7.1 Low-side configured output fault operation

The diagnostic circuitry verifies for the low-side configured output the following condition: Normal operation, open load, short circuit to GND and overcurrent (only if the switching OFF protection, selectable for each channel via SPI bus, is active).

The diagnostic circuitry operates in two different modes, selected for each channel by SPI: no latch mode and latch mode. The fault priority is overcurrent and then open load or short circuit to GND, this means that if an overcurrent occurs the fault register is always overwritten and following open load or short to GND faults that happen before that the register is cleared will be ignored.

7.1.1 No latch mode

This diagnostic operating mode doesn't latch open load and short to GND faults.

1. Open load

The diagnostic of open load is detected only in OFF condition sensing the Drn1-8 output voltage. This fault is detected on the falling edge of the CS input if the power

drain voltage is inside the voltage range limited by the two thresholds **Vth_Vbat** and **Vth_GND**. An internal current limited voltage regulator fixes the drain voltage inside the described range when no load is connected.

2. **Short circuit to GND**

The diagnostic of short circuit to GND is detected only in OFF condition sensing the Drn1-8 output voltage. This fault is detected on the falling edge of the CS input if the power drain voltage is lower than the **Vth_GND** threshold.

3. **Overcurrent**

The diagnostic of overcurrent is detected only in ON condition, if the switching OFF protection of the channel is enabled (default), sensing the current level of the output power transistor. If the output current has been above the short threshold **lovc** for the filtering time **Tdel** the output power is switched off and at the same time an overcurrent fault is written in the fault register.

There are three possibilities to restart one output after the fault has occurred:

- Automatically after a time **Tres**
- On the rising edge of CS if two valid DI byte has been received and first the Output Status in the command register is written with logic '0' and then with a logic "1" in the following SPI cycle
- On the rising edge (low to high transition) at the corresponding parallel input pin (only for Outputs 6-8).
- If the switching OFF protection is not active the On phase overcurrent protection is a linear current limitation and no diagnosis is available.

The use of the IN6-8 pins for PWM control on the outputs 6-8 could generates bad diagnostic behavior when the falling edge of CS happens a short time after the falling edge of IN6-8 during the power MOS transient. Software filtering may be needed to ignore fault signals during Drn6-8 transient after falling edge of IN6-8.

7.1.2 Latch mode

This diagnostic operating mode latches all faults when they happen.

1. **Open load**

The diagnostic of open load is detected only in OFF condition sensing the Drn1-8 output voltage. This fault is detected if the power drain voltage is inside the voltage range limited by the two thresholds **Vth_Vbat** and **Vth_GND** for the filtering time **Tfilt**. An internal current limited voltage regulator fixes the drain voltage inside the described range when no load is connected.

2. **Short circuit to GND**

The diagnostic of short circuit to GND is detected only in OFF condition sensing the Drn1-8 output voltage. This fault is detected if the power drain voltage is lower than the **Vth_GND** threshold for the filtering time **Tfilt**.

3. **Overcurrent**

The diagnostic of overcurrent is detected only in ON condition, if the switching OFF protection of the channel is enabled (default), sensing the current level of the output power transistor. If the output current has been above the short threshold **lovc** for the filtering time **Tdel** the output power is switched off and at the same time an overcurrent fault is written in the fault register. If the switching OFF protection is not active the On

phase overcurrent protection is a linear current limitation and no diagnosis is available. There are three possibilities to restart one output after the fault has occurred:

- Automatically after a time **Tres**
- On the rising edge of CS if two valid DI byte has been received and first the Output Status in the command register is written with logic '0' and then with a logic "1" in the following SPI cycle
- On the rising edge (low to high transition) at the corresponding parallel input pin (only for Outputs 6-8).
If the power MOS transient, after a switching-off command, is longer than Tdel filtering time, a bad diagnostic behavior happens and software filtering may be needed.

7.2 High-side configured output fault operation

The diagnostic circuitry verifies for the high-side configured output the following condition: Normal operation, open load, short circuit to Vbat and overcurrent (only if the switching OFF protection, selectable for each channel via SPI bus, is active).

The diagnostic circuitry operates in two different modes, selected for each channel by SPI: no latch mode and latch mode. The fault priority is overcurrent and then open load or short circuit to Vb, this means that if an overcurrent occurs the fault register is always overwritten and following open load or short to Vbat faults that happen before that the register is cleared will be ignored.

7.2.1 No latch mode

This diagnostic operating mode doesn't latch open load and short to Vbat faults.

1. Open load

The diagnostic of open load is detected only in OFF condition sensing the Src1-8 output voltage. This fault is detected on the falling edge of the CS input if the power drain voltage is inside the voltage range limited by the two thresholds Vth_Vbat and Vth_GND. An internal current limited voltage regulator fixes the drain voltage inside the described range when no load is connected.

2. Short Circuit to Vb

The diagnostic of short circuit to Vbat is detected only in OFF condition sensing the Src1-8 output voltage. This fault is detected on the falling edge of the CS input if the power drain voltage is higher than the **Vth_Vbat** threshold.

3. Overcurrent

The diagnostic of overcurrent is detected only in ON condition, if the switching OFF protection of the channel is enabled (default), sensing the current level of the output power transistor. If the output current has been above the short threshold Iovc for the filtering time Tdel the output power is switched off and at the same time an overcurrent fault is written in the fault register.

There are three possibilities to restart one output after the fault has occurred:

- Automatically after a time **Tres**
- On the rising edge of CS if two valid DI byte has been received and first the Output Status in the command register is written with logic '0' and then with a logic "1" in the following SPI cycle

- On the rising edge (low to high transition) at the corresponding parallel input pin (only for Outputs 6-8).
- If the switching OFF protection is not active the On phase overcurrent protection is a linear current limitation and no diagnosis is available.
The use of the IN6-8 pins for PWM control on the outputs 6-8 could generate bad diagnostic behavior when the falling edge of CS happens a short time after the falling edge of IN6-8 during the power MOS transient. Software filtering may be needed to ignore fault signals during Drn6-8 transient after falling edge of IN6-8.

7.2.2 Latch mode

This diagnostic operating mode latches all faults when they happen.

1. Open load

The diagnostic of open load is detected only in OFF condition sensing the Src1-8 output voltage. This fault is detected if the power drain voltage is inside the voltage range limited by the two thresholds **Vth_Vbat** and **Vth_GND** for the filtering time **Tfilt**. An internal current limited voltage regulator fixes the drain voltage inside the described range when no load is connected.

2. Short Circuit to Vb

The diagnostic of short circuit to Vbat is detected only in OFF condition sensing the Src1-8 output voltage. This fault is detected if the power drain voltage is higher than the **Vth_Vbat** threshold for the filtering time **Tfilt**.

3. Overcurrent

The diagnostic of overcurrent is detected only in ON condition, if the switching OFF protection of the channel is enabled (default), sensing the current level of the output power transistor. If the output current has been above the short threshold **lovc** for the filtering time **Tdel** the output power is switched off and at the same time an overcurrent fault is written in the fault register.

There are three possibilities to restart one output after the fault has occurred:

- Automatically after a time **Tres**
- On the rising edge of CS if two valid DI byte has been received and first the Output Status in the command register is written with logic '0' and then with a logic "1" in the following SPI cycle
- On the rising edge (low to high transition) at the corresponding parallel input pin (only for Outputs 6-8).
If the switching OFF protection is not active the On phase overcurrent protection is a linear current limitation and no diagnosis is available.

If the power MOS transient, after a switching-off command, is longer than **Tdel** filtering time, a bad diagnostic behavior happens and software filtering may be needed.

Figure 7. L9733 application schematic

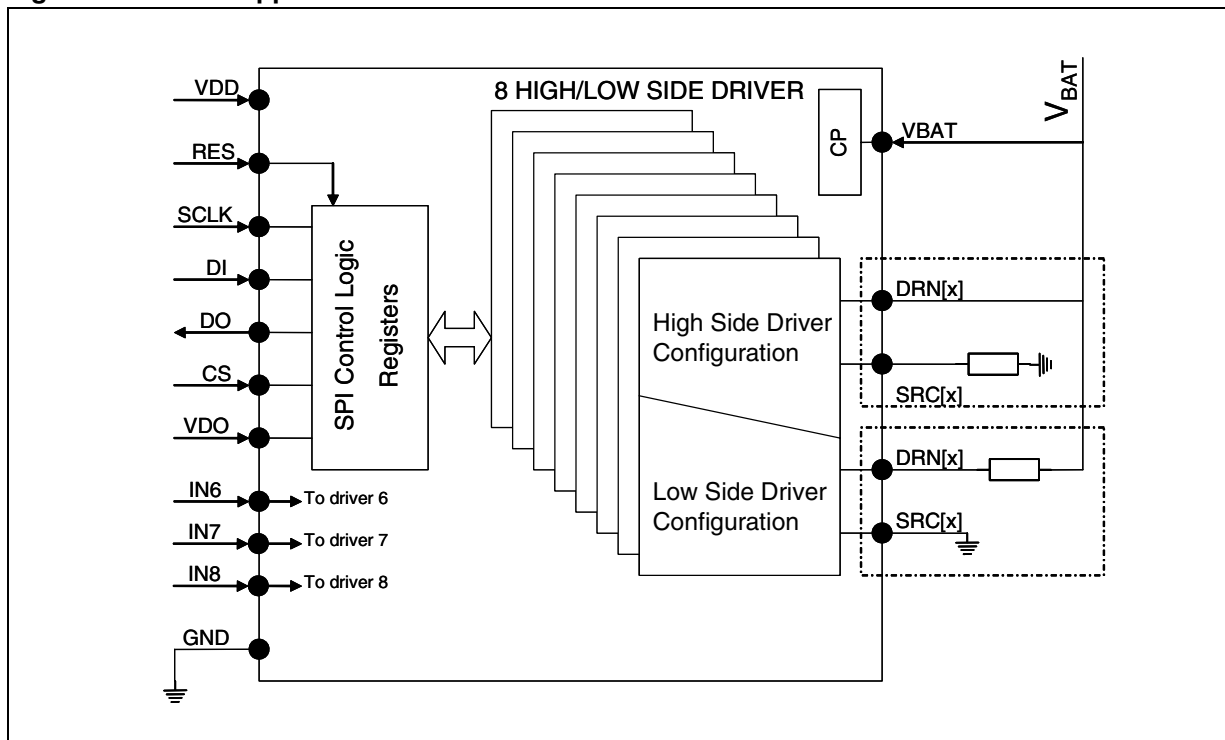

Figure 8. L9733 HVAC applicative examples

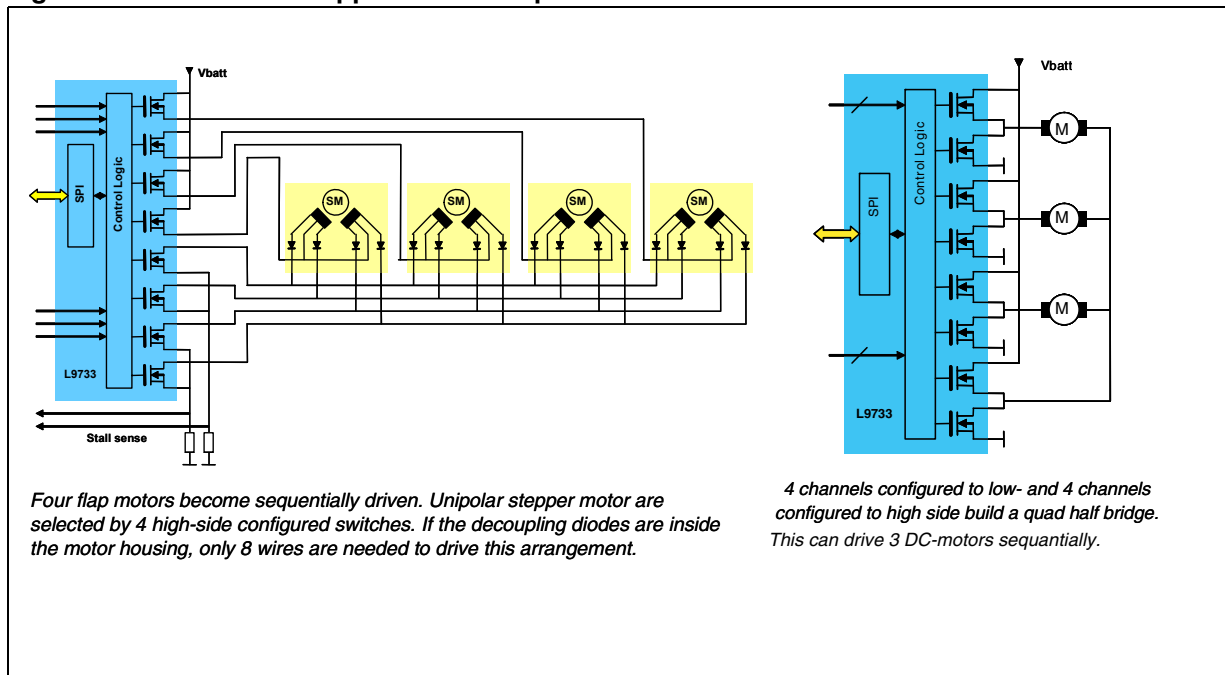
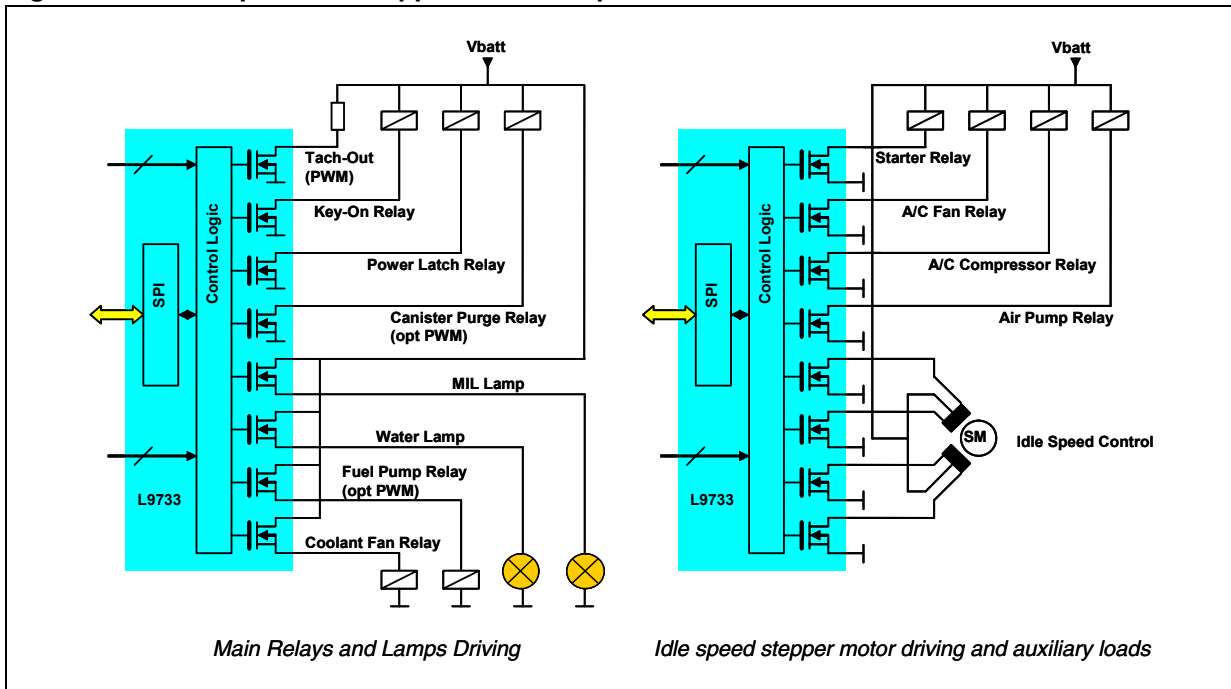
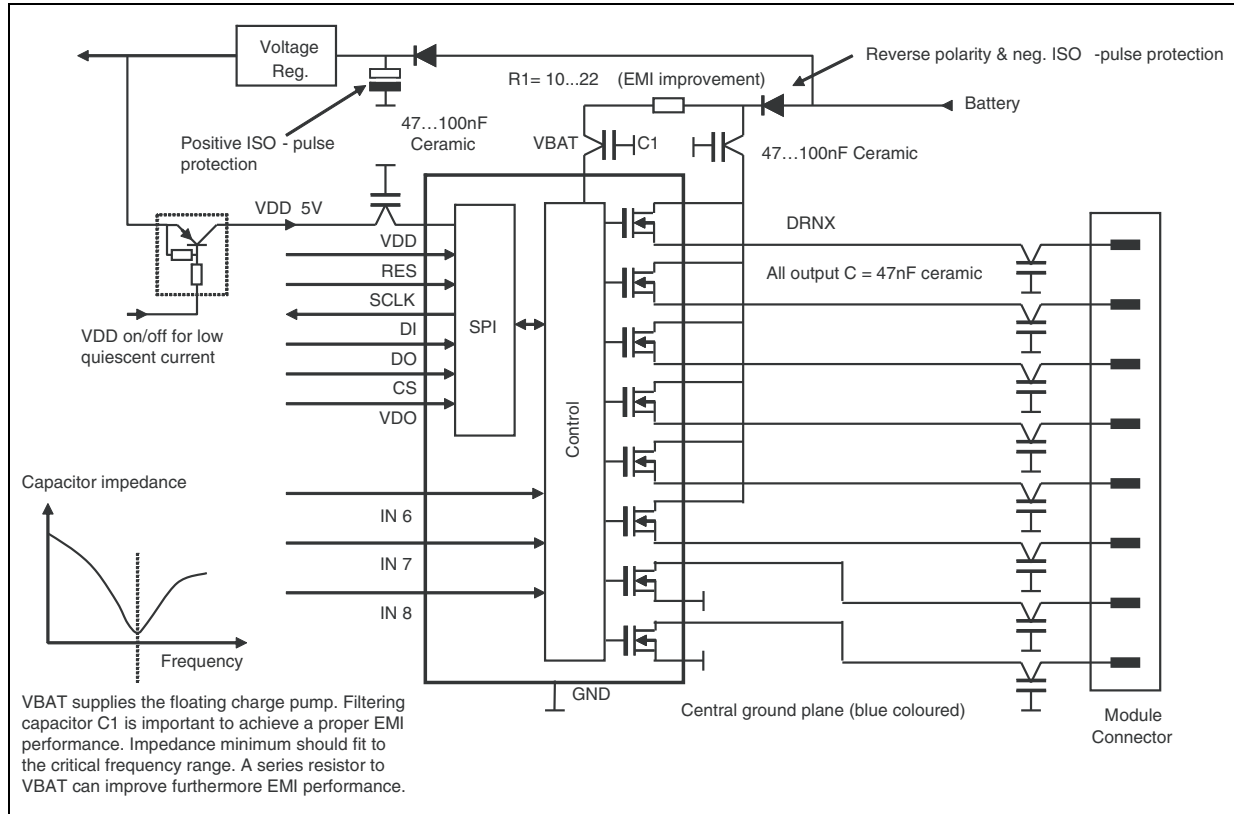

Figure 9. L9733 powertrain applicative examples



8 Application circuit

Figure 10. Optimized circuit layout to achieve proper EMI/ESD capability



9 Package information

In order to meet environmental requirements, ST offers these devices in different grades of ECOPACK® packages, depending on their level of environmental compliance. ECOPACK® specifications, grade definitions and product status are available at: www.st.com.

ECOPACK® is an ST trademark.

Figure 11. PowerSSO28 mechanical data and package dimensions

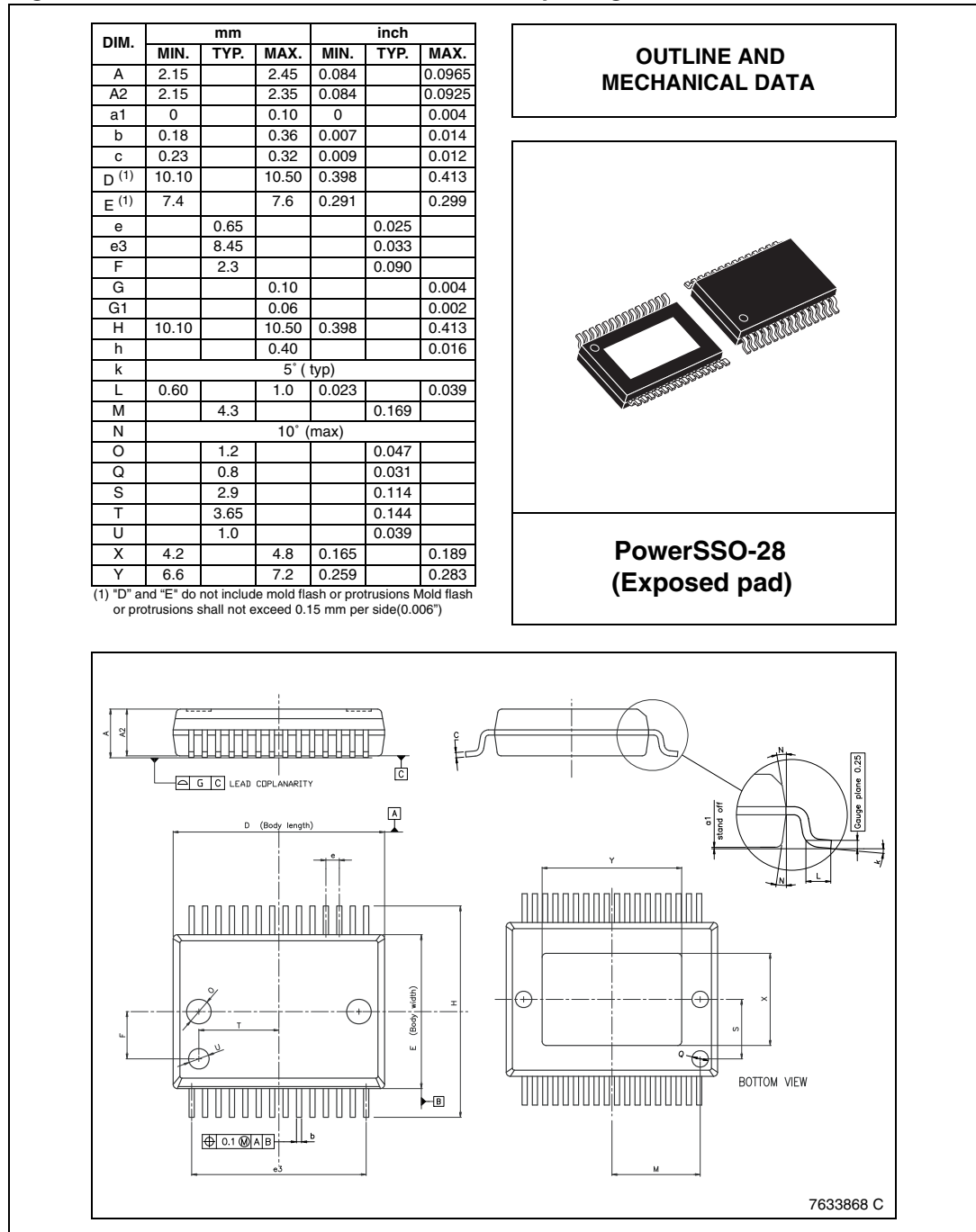

10 Revision history

Table 13. Document revision history

Date	Revision	Changes
13-Apr-2005	1	Initial release.
15-Jun-2006	2	Changed only look and feel.
08-Aug-2006	3	Modified Table 9: Bit command register definition on page 22 .
28-May-2007	4	Changed the min. value of the CSlead parameter on the Table 8 .
17-Jul-2007	5	Updated Table 6 and Table 7 . Added new Figure 4 . Changed the status from Preliminary data to Datasheet.
03-Aug-2007	6	Updated in Table 4 the ESD parameter.
12-Jun-2008	7	Added order codes in Table 1: Device summary . Added "CS2SCLK" parameter in Table 8: SPI characteristics and timings . Updated Figure 6: SPI timing diagram .
02-Dec-2008	8	Updated Table 1: Device summary on page 1 . Removed all references to the SO-28 package. Updated Section 2.1: Operating range and Section 2.2: Absolute maximum ratings . Added Section 2.1.1: Functional operative range , Section 2.1.2: Jump start conditions , Section 2.1.3: Operation at low battery condition and Section 2.1.4: Operation at load dump condition . Added Section 8: Application circuit . Added "POR _{th} " parameter in Table 6: DC characteristics .
13-May-2009	9	Updated Table 1: Device summary on page 1 . Updated Figure 11: PowerSSO28 mechanical data and package dimensions .
27-Jul-2010	10	Updated Table 1: Device summary on page 1 . Updated Section 7: Fault operation on page 25 .
19-Sep-2013	11	Updated Disclaimer.

Please Read Carefully:

Information in this document is provided solely in connection with ST products. STMicroelectronics NV and its subsidiaries ("ST") reserve the right to make changes, corrections, modifications or improvements, to this document, and the products and services described herein at any time, without notice.

All ST products are sold pursuant to ST's terms and conditions of sale.

Purchasers are solely responsible for the choice, selection and use of the ST products and services described herein, and ST assumes no liability whatsoever relating to the choice, selection or use of the ST products and services described herein.

No license, express or implied, by estoppel or otherwise, to any intellectual property rights is granted under this document. If any part of this document refers to any third party products or services it shall not be deemed a license grant by ST for the use of such third party products or services, or any intellectual property contained therein or considered as a warranty covering the use in any manner whatsoever of such third party products or services or any intellectual property contained therein.

UNLESS OTHERWISE SET FORTH IN ST'S TERMS AND CONDITIONS OF SALE ST DISCLAIMS ANY EXPRESS OR IMPLIED WARRANTY WITH RESPECT TO THE USE AND/OR SALE OF ST PRODUCTS INCLUDING WITHOUT LIMITATION IMPLIED WARRANTIES OF MERCHANTABILITY, FITNESS FOR A PARTICULAR PURPOSE (AND THEIR EQUIVALENTS UNDER THE LAWS OF ANY JURISDICTION), OR INFRINGEMENT OF ANY PATENT, COPYRIGHT OR OTHER INTELLECTUAL PROPERTY RIGHT.

ST PRODUCTS ARE NOT DESIGNED OR AUTHORIZED FOR USE IN: (A) SAFETY CRITICAL APPLICATIONS SUCH AS LIFE SUPPORTING, ACTIVE IMPLANTED DEVICES OR SYSTEMS WITH PRODUCT FUNCTIONAL SAFETY REQUIREMENTS; (B) AERONAUTIC APPLICATIONS; (C) AUTOMOTIVE APPLICATIONS OR ENVIRONMENTS, AND/OR (D) AEROSPACE APPLICATIONS OR ENVIRONMENTS. WHERE ST PRODUCTS ARE NOT DESIGNED FOR SUCH USE, THE PURCHASER SHALL USE PRODUCTS AT PURCHASER'S SOLE RISK, EVEN IF ST HAS BEEN INFORMED IN WRITING OF SUCH USAGE, UNLESS A PRODUCT IS EXPRESSLY DESIGNATED BY ST AS BEING INTENDED FOR "AUTOMOTIVE, AUTOMOTIVE SAFETY OR MEDICAL" INDUSTRY DOMAINS ACCORDING TO ST PRODUCT DESIGN SPECIFICATIONS. PRODUCTS FORMALLY ESCC, QML OR JAN QUALIFIED ARE DEEMED SUITABLE FOR USE IN AEROSPACE BY THE CORRESPONDING GOVERNMENTAL AGENCY.

Resale of ST products with provisions different from the statements and/or technical features set forth in this document shall immediately void any warranty granted by ST for the ST product or service described herein and shall not create or extend in any manner whatsoever, any liability of ST.

ST and the ST logo are trademarks or registered trademarks of ST in various countries.

Information in this document supersedes and replaces all information previously supplied.

The ST logo is a registered trademark of STMicroelectronics. All other names are the property of their respective owners.

© 2013 STMicroelectronics - All rights reserved

STMicroelectronics group of companies

Australia - Belgium - Brazil - Canada - China - Czech Republic - Finland - France - Germany - Hong Kong - India - Israel - Italy - Japan - Malaysia - Malta - Morocco - Philippines - Singapore - Spain - Sweden - Switzerland - United Kingdom - United States of America

www.st.com