

Octal squib driver and quad sensor interface ASIC for safety application

Features

- 8 deployment drivers sized to deliver 1.2 A (min) for 2 ms (min) and 1.75 A (min) for 1 ms (min)
- Independently controlled high-side and low-side MOS for diagnosis
- Analog output available for resistance
- Squib short to ground, short to battery and MOS diagnostic available on SPI register
- Capability to deploy the squib with 1.2 A (min) or 1.75 A under 35 V load-dump condition and the low side MOS is shorted to ground
- Capability to deploy the squib with 1.2 A (min) at 6.9 V VRES and 1.75 A at 12 V VRES
- Interface with 4 satellite sensors
- Programmable independent current trip points for each satellite channel
- Support Manchester protocol for satellite sensors
- Supports for variable bit rate detection
- Independent current limit and fault timer shutdown protection for each satellite output
- Short to ground and short to battery detection and reporting for each satellite channel
- 5.5 MHz SPI interface
- Satellite message error detection

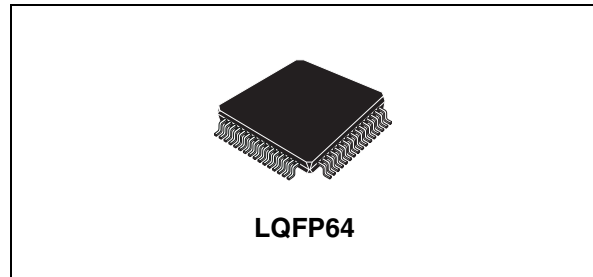

- Hall effect sensor support on satellite channels 3 and 4.
- Low voltage internal reset
- 2 kV ESD capability on all pins
- Package: 64 leads LQFP
- Technology: ST proprietary BCD5s (0.57 μm)

Description

L9658 is intended to deploy up to 8 squibs and to interface up to 4 satellites. 2 satellite interfaces can be used to interface Hall sensors.

Squib drivers are sized to deploy 1.2 A minimum for 2 ms minimum during load dump and 1.75 A minimum for 1ms minimum during load dump.

Diagnostic of squib driver and squib resistance measurement is controlled by micro controller.

Satellite interfaces support Manchester decoder with variable bit rate.

Table 1. Device summary

Order code	Package	Packing
L9658	LQFP64	Tray
L9658TR	LQFP64	Tape and reel

Contents

- 1 Block diagram and application schematic 7**
 - 1.1 Block diagram 7
 - 1.2 Application schematic 7

- 2 Pin description 8**
 - 2.1 Thermal data 9

- 3 Electrical specification 10**
 - 3.1 Maximum ratings 10
 - 3.2 Absolute maximum ratings 10
 - 3.3 Electrical characteristics 11
 - 3.3.1 DC characteristics 11
 - 3.3.2 AC characteristics 14

- 4 Functional description 18**
 - 4.1 Overview 18
 - 4.2 Power on reset (POR) 18
 - 4.3 RESETB 18
 - 4.4 MSG 18
 - 4.5 IREF 19
 - 4.6 Loss of ground 19
 - 4.7 Deployment and reset 19
 - 4.8 Serial peripheral interface (SPI) 19
 - 4.8.1 Chip select (CS_A, CS_D, CS_S) 21
 - 4.8.2 Serial clock (SCLK, SCLK_A) 21
 - 4.8.3 Serial data output (MISO, MISO_A) 21
 - 4.8.4 Serial data input (MOSI, MOSI_A) 22
 - 4.9 Deployment drivers 22
 - 4.9.1 Arming interface 23
 - 4.10 DEPEND 25
 - 4.10.1 Deployment driver diagnostic 26
 - 4.10.2 Continuity diagnostic 27
 - 4.10.3 Short to battery 27

4.10.4	Short to ground and open circuit	27
4.10.5	Resistance measurement	28
4.10.6	MOS diagnostics	28
4.10.7	Low side MOS diagnostic	28
4.10.8	High side MOS diagnostic	30
4.10.9	Loss of ground	30
4.11	Deployment driver SPI bit definition	32
4.11.1	Deployment driver MOSI bit definition	32
4.11.2	Deployment driver register mode	33
4.11.3	Deployment driver command mode	34
4.11.4	Deployment driver diagnostic mode	35
4.11.5	Example of short between loops diagnostic	38
4.11.6	Deployment driver monitor mode	39
4.11.7	Deployment driver MISO bit definition	41
4.11.8	Deployment driver register mode response	41
4.12	MISO register mode response summary	42
4.12.1	Deployment driver command mode response	43
4.12.2	Deployment driver diagnostic mode response	44
4.12.3	Deployment driver status response	45
4.12.4	Deployment driver SPI fault response	46
4.13	Arming SPI bit definition	46
4.13.1	Arming MOSI_A bit definition	46
4.13.2	ARM[01..67]	46
4.13.3	ARM[01..67]*	47
4.13.4	Arming MISO_A bit definition	47
4.13.5	ARM[01..67]	47
4.14	Satellite sensor interface	47
4.14.1	Current sensor	48
4.14.2	Manchester decoding	48
4.14.3	Communication protocols	50
4.14.4	"A" protocol	50
4.14.5	"B" variable length protocol	50
4.14.6	FIFO buffer	51
4.14.7	Satellite continuity check	51
4.14.8	(IFx/Vx) hall effect support mode	51
4.14.9	(IFx/Vx) raw data out mode	51
4.14.10	Message waiting	52

4.14.11	Satellite serial data input (MOSI)	52
4.14.12	Satellite MOSI bits definition	52
4.14.13	Satellite module configuration register (CH1 only)	53
4.14.14	Channel configuration registers (CCR1, CCR2, CCR3, CCR4)	54
4.14.15	SPI MISO Bits layout for configuration report	58
5	Package information	62
6	Revision history	63

List of tables

Table 1.	Device summary	1
Table 2.	Pin function	8
Table 3.	Thermal Data	9
Table 4.	Maximum operating conditions	10
Table 5.	Absolute maximum ratings	10
Table 6.	DC specification general	11
Table 7.	DC Specification: deployment drivers	12
Table 8.	Satellite interface DC specifications	13
Table 9.	AC specification: deployment drivers	14
Table 10.	AC specifications: satellite	16
Table 11.	SPI timing	17
Table 12.	SPI transmission during a deployment	25
Table 13.	Deployment driver SPI response	32
Table 14.	MOSI bit layout	32
Table 15.	MOSI mode bits definition	32
Table 16.	MOSI register mode message definition	33
Table 17.	Pulse stretch timer	34
Table 18.	MOSI command mode message definition	34
Table 19.	MOSI diagnostic mode message definition	35
Table 20.	Channel selection decoding	37
Table 21.	MOSI monitor mode message definition	39
Table 22.	MISO bit layout	41
Table 23.	MISO mode bits definition	41
Table 24.	MISO register mode response definition	41
Table 25.	MISO register mode response summary	42
Table 26.	MISO command mode response definition	43
Table 27.	MISO diagnostic mode response definition	44
Table 28.	MISO status response definition	45
Table 29.	MISO SPI fault response	46
Table 30.	Arming MOSI_A bit definition	46
Table 31.	Arming MISO_A bit definition	47
Table 32.	Satellite MOSI bits layout	52
Table 33.	MOSI satellite interface registers map	52
Table 34.	Master configuration register definition (CH1 Only)	53
Table 35.	Channel configuration register definition	54
Table 36.	Current ranges supported are given in following table	55
Table 37.	Satellite/decoder control	55
Table 38.	"B" protocol configuration	56
Table 39.	Bit time selection	56
Table 40.	Mode select	56
Table 41.	SPI mode selects reply for satellite channels	57
Table 42.	Satellite MISO bits definition	57
Table 43.	SPI MISO bits layout when reporting FIFO data	58
Table 44.	MISO Manchester message data definition	58
Table 45.	Status bits definition	58
Table 46.	Satellites fault codes definition supporting "A" protocol	58
Table 47.	Satellites fault codes definition supporting "B" protocol	60
Table 48.	Hall effect fault codes definition (CH3 and CH4) only	60
Table 49.	Document revision history	63

List of figures

Figure 1.	Block diagram	7
Figure 2.	Application schematic	7
Figure 3.	MOS settling time and turn-on time 1	15
Figure 4.	MOS settling time and turn-on time 2	15
Figure 5.	SPI timing diagram	17
Figure 6.	SPI timing measurement	17
Figure 7.	SPI block diagram	20
Figure 8.	Arming daisy-chain configuration	20
Figure 9.	Arming SPI transmission	21
Figure 10.	Deployment drivers diagram	22
Figure 11.	Deployment sequence	23
Figure 12.	Deployment flow chart	24
Figure 13.	Deployment driver diagnostic diagram	26
Figure 14.	Continuity diagnostic flow chart	27
Figure 15.	Resistance measurement flow chart	28
Figure 16.	Low side diagnostic flow chart	29
Figure 17.	High side driver diagnostic flow chart	31
Figure 18.	Satellite interface block diagram	47
Figure 19.	Manchester decoding	48
Figure 20.	Manchester decoding using satellite protocol as an example	49
Figure 21.	"A" satellite protocol	50
Figure 22.	"B" satellite protocol	50
Figure 23.	LQFP64 mechanical data and package dimensions	62

1 Block diagram and application schematic

1.1 Block diagram

Figure 1. Block diagram

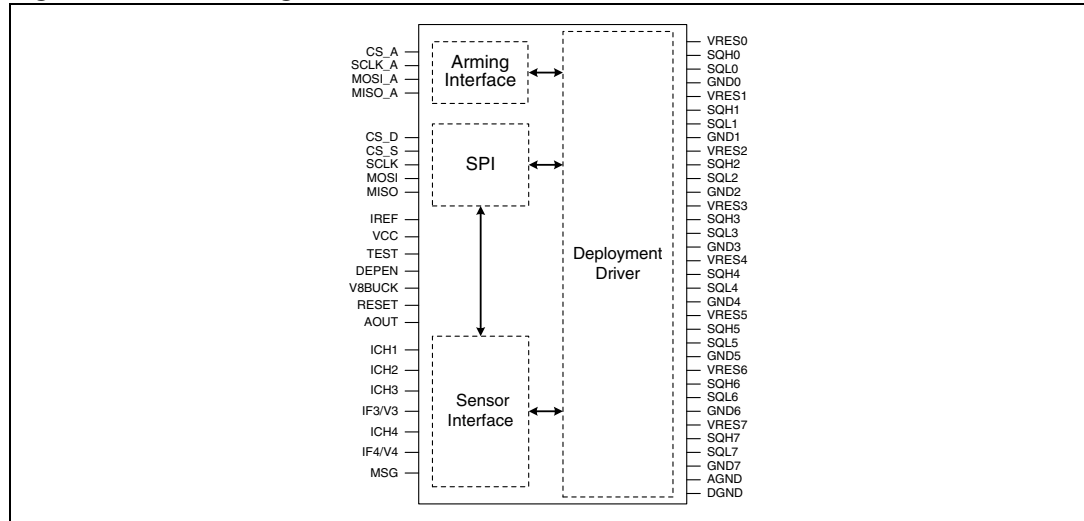

1.2 Application schematic

Figure 2. Application schematic

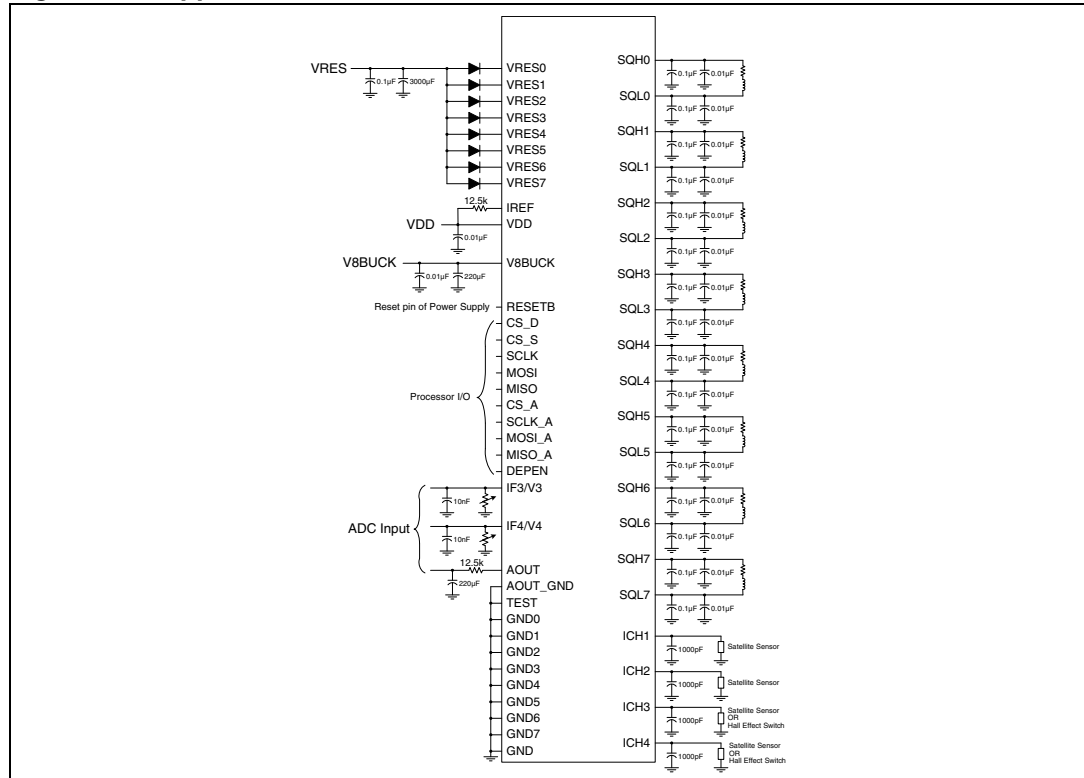

2 Pin description

Table 2. Pin function

Pin #	Pin name	Description	I/O type	Reset state
1	MSG	Message waiting	Output	Pull-down
2	MISO	SPI data out	Output	Hi-Z
3	MISO_A	Arming SPI data out	Output	Hi-Z
4	NC	No connect	-	-
5	RESETB	Reset pin	Input	Pull-up
6	GND	Signal ground (analog & digital)	-	-
7	VDD	VDD supply voltage	Input	-
8	NC	No connect	-	-
9	CS_A	SPI chip select for arming interface	Input	Pull-down
10	CS_S	SPI chip select for satellite interface	Input	Pull-down
11	CS_D	SPI chip select for deployment driver	Input	Pull-down
12	DEPEN	Deployment enable	Input	Pull-down
13	MOSI	SPI data in	Input	Hi-Z
14	MOSI_A	Arming SPI data in	Input	Hi-Z
15	SCLK_A	Arming SPI Clock	Input	Hi-Z
16	SCLK	SPI clock	Input	Hi-Z
17	GND4	Power ground for loop channel 4	-	-
18	SQL4	Low side driver output for channel 4	Output	Pull-down
19	SQH4	High side driver output for channel 4	Output	Hi-Z
20	VRES4	Reserve voltage for loop channel 4	Input	-
21	VRES5	Reserve voltage for loop channel 5	Input	-
22	SQH5	High side driver output for channel 5	Output	Hi-Z
23	SQL5	Low side driver output for channel 5	Output	Pull-down
24	GND5	Power ground for loop channel 5	-	-
25	GND6	Power ground for loop channel 6	-	-
26	SQL6	Low side driver output for channel 6	Output	Pull-down
27	SQH6	High side driver output for channel 6	Output	Hi-Z
28	VRES6	Reserve voltage for loop channel 6	Input	-
29	VRES7	Reserve voltage for loop channel 7	Input	-
30	SQH7	High side driver output for channel 7	Output	Hi-Z
31	SQL7	Low side driver output for channel 7	Output	Pull-down
32	GND7	Power ground for loop channel 7	-	-
33	NC	No connect	-	-
34	IF4/V4	Current feedback for channel 4 raw or raw data output for channel 4	Output	Hi-Z
35	IF3/V3	Current feedback for channel 3 raw or data output for channel 3	Output	Hi-Z

Table 2. Pin function (continued)

Pin #	Pin name	Description	I/O type	Reset state
36	NC	No Connect	-	-
37	TEST	Test pin	Input	Pull-down
38	V8BUCK	Supply voltage for satellite interface and resistance measurement	Input	-
39	NC	No Connect	-	-
40	ICH4	Current sense output for channel 4	Output	Hi-Z
41	ICH3	Current sense output for channel 3	Output	Hi-Z
42	ICH2	Current sense output for channel 2	Output	Hi-Z
43	ICH1	Current sense output for channel 1	Output	Hi-Z
44	NC	No connect	-	-
45	IREF	External current reference resistor	Output	-
46	AOUT_GND	Ground reference for AOUT	-	-
47	AOUT	Analog output for loop diagnostics	Output	Hi-Z
48	NC	No Connect	-	-
49	GND3	Power ground for loop channel 3	-	-
50	SQL3	Low side driver output for channel 3	Output	Pull-down
51	SQH3	High side driver output for channel 3	Output	Hi-Z
52	VRES3	Reserve voltage for loop channel 3	Input	-
53	VRES2	Reserve voltage for loop channel 2	Input	-
54	SQH2	High side driver output for channel 2	Output	Hi-Z
55	SQL2	Low side driver output for channel 2	Output	Pull-down
56	GND2	Power ground for loop channel 2	-	-
57	GND1	Power ground for loop channel 1	-	-
58	SQL1	Low side driver output for channel 1	Output	Pull-down
59	SQH1	High Side Driver Output for Channel 1	Output	Hi-Z
60	VRES1	Reserve voltage for loop channel 1	Input	-
61	VRES0	Reserve voltage for loop channel 0	Input	-
62	SQH0	High side driver output for channel 0	Output	Hi-Z
63	SQL0	Low side driver output for channel 0	Output	Pull-down
64	GND0	Power ground for loop channel 0	-	-

2.1 Thermal data

Table 3. Thermal Data

Symbol	Parameter	Value.	Unit
$R_{th\ j-amb}$	Thermal resistance junction-to-ambient	68	°C/W

3 Electrical specification

3.1 Maximum ratings

The device may not operate properly if maximum operating condition is exceeded.

Table 4. Maximum operating conditions

Symbol	Parameter	Value	Unit
V_{DD}	Supply voltage	4.9 to 5.1	V
V_{8BUCK}	V8BUCK voltage	7 to 8.5	V
V_{RES}	VRES voltage (VRES0, VRES1, VRES2, VRES3, VRES4, VRES5, VRES6, VRES7)	35	V
V_I	Discrete input voltage (RESETB, DEPEND, CS_A, CS_D, CS_S, SCLK, SCLK_A, MOSI, MOSI_A, MISO, MISO_A)	-0.3 to ($V_{DD} + 0.3$)	V
T_j	Junction temperature	-40 to 150	°C

3.2 Absolute maximum ratings

Caution: Maximum ratings are absolute ratings; exceeding any one of these values may cause permanent damage to the integrated circuit.

Table 5. Absolute maximum ratings

Symbol	Parameter	Value	Unit
V_{DD}	Supply voltage	-0.3 to 5.5	V
V_{8BUCK}	V8BUCK voltage	-0.3 to 40	V
V_{RES}	VRES Voltage (VRES0, VRES1, VRES2, VRES3, VRES4, VRES5, VRES6, VRES7)	-0.3 to 40	V
SQ_{L-H}	Squib high and low side drivers (SQH0, SQH1, SQH2, SQH3, SQH4, SQH5, SQH6, SQH7, SQL0, SQL1, SQL2, SQL3, SQL4, SQL5, SQL6, SQL7)	-0.3 to 40	V
V_I	Discrete input voltage (RESETB, DEPEND, CS_A, CS_D, CS_S, SCLK, SCLK_A, MOSI, MOSI_A, MISO, MISO_A)	-0.3 to 5.5	V
ICHx	Satellite input voltage (ICH1, ICH2, ICH3, ICH4)	-3 to 40	V
-	Analog/digital outputs voltage (AOUT, IREF, MSG, IF3V3, IF4V4)	-0.3 to 5.5	V
GNDx	Ground pins voltage (GND, AOUT_GND, GND0, GND1, GND2, GND3, GND4, GND5, GND6, GND7)	-0.3 to 5.5	V
T_j	Maximum steady-state junction temperature	150	°C
T_{amb}	Ambient temperature	-40 to 95	°C
T_{stg}	Storage temperature	-65 to 150	°C

3.3 Electrical characteristics

3.3.1 DC characteristics

$V_{RES} = 6.5$ to 35 V, $V_{DD} = 4.9$ to 5.1 V, $V_{8BUCK} = 7.0$ V to 8.5 V, $T_{amb} = -40$ °C to $+95$ °C

Table 6. DC specification general

Symbol	Parameter	Test condition	Min.	Typ	Max.	Unit
$V_{RST}^{(1)}$	Internal voltage reset V_{DD}	V_{DD} drops until deployment drivers are disabled	4.0	-	4.5	V
$V_{RST_L}^{(2)}$			2.1	-	3.0	
I_{DD}	Input current V_{DD}	Normal operation; $I_{CH1-4} = 0$ A	6.2	-	8.6	mA
		Short to -0.3 V on SQH; $I_{CH1-4} = 0$ A	5.5	-	9.5	
		Short to -0.3 V on SQL; $I_{CH1-4} = 0$ A	5.5	-	9.5	
		Deployment; $I_{CH1-4} = 0$ A	5.5	-	9.5	
R_{IREF_H}	Resistance threshold I_{REF}	-	20.0	-	60.0	k Ω
R_{IREF_L}		-	2.0	-	9.0	k Ω
V_{IH_RESETB}	Input voltage threshold RESETB	-	-	-	2.0	V
V_{IL_RESETB}		-	0.8	-	-	V
V_{HYS}		-	100	-	400	mV
V_{IH_DEPEN}	Input voltage threshold DEPEN	-	-	-	2.0	V
V_{IL_DEPEN}		-	0.8	-	-	V
I_{PD}	Input pull-down current DEPEN	$V_{IN} = V_{IL}$ to V_{DD}	10	-	50	μ A
V_{IH_TEST}	Input voltage threshold TEST	-	-	-	3.6	V
V_{IL_TEST}		-	0.8	-	-	V
I_{TEST}	Input pull-down current TEST	TEST = 5 V	1.0	-	2.5	mA
I_{PU}	Input pull-up current RESETB	RESETB = V_{IH} to GND	10	-	60	μ A
I_{V8BUCK}	Current consumption V8BUCK	-	25	-	40	μ A
V_{IH}	Input voltage threshold MOSI, MOSI_A, SCLK, SCLK_A, CS_S, CS_D, CS_A	Input logic = 1	-	-	2.0	V
V_{IL}		Input logic = 0	0.8	-	-	V
V_{HYS}		-	100	-	400	mV
I_{LKG}	Input leakage current MOSI, MOSI_A, SCLK, SCLK_A	$V_{IN} = V_{DD}$	-	-	1	μ A
		$V_{IN} = 0$ to V_{IH}	-1	-	-	μ A
I_{PD}	Input pull-down current CS_S, CS_D, CS_A	$V_{IN} = V_{IL}$ to V_{DD}	10	-	50	μ A
V_{OH}	Output voltage MISO, MISO_A, MSG	$I_{OH} = -800$ μ A	$V_{DD}-0.8$	-	-	V
V_{OL}		$I_{OL} = 1.6$ mA	-	-	0.4	V
I_{HI_Z}	Tri-state current MISO, MISO_A,	MISO = VDD	-	-	1	μ A
		MISO = 0 V	-1	-	-	μ A

1. V_{RST} shall have a POR de-glitch timer.

2. V_{RST_L} shall have no timer.

$V_{RES} = 6.5$ to 35 V, $V_{DD} = 4.9$ to 5.1 V, $V_{8BUCK} = 7.0$ V to 8.5 V, $T_{amb} = -40$ °C to $+95$ °C

Table 7. DC Specification: deployment drivers

Symbol	Parameter	Test conditions	Min.	Typ	Max.	Units
V_{OH}	Output voltage AOUT	High saturation voltage; $I_{AOUT} = -500 \mu A$	$V_{DD} - 0.4$	-	-	V
V_{OL}		Low saturation voltage; $I_{AOUT} = +500 \mu A$	-	-	0.3	V
I_Z	Tri-state current AOUT	AOUT = V_{DD}	-	-	1	μA
		AOUT = 0 V	-1	-	-	μA
I_{LKG}	Leakage current SQH	$V_{8BUCK} = V_{DD} = 0$, $V_{RES} = 36$ V, $V_{SQH} = 0$ V	-	-	50	μA
I_{STG}		$V_{8BUCK} = 18$ V; $V_{DD} = 5$ V; $V_{SQH} = -0.3$ V	-5	-	-	mA
I_{LKG}	Bias current VRES ⁽¹⁾	$V_{8BUCK} = 18$ V; $V_{DD} = 5$ V; $V_{RES} = 36$ V; SQH shorted to SQL	-	-	10	μA
I_{LKG}	Leakage current SQL	$V_{8BUCK} = V_{DD} = 0$, $V_{SQL} = 18$ V	-10	-	10	μA
I_{STG}		$V_{8BUCK} = 18$ V; $V_{DD} = 5$ V; $V_{SQL} = -0.3$ V	-5	-	-	mA
I_{STB}		$V_{8BUCK} = 18$ V; $V_{DD} = 5$ V; $V_{SQL} = 18$ V	-	-	5	mA
I_{PD}	Pull-down current SQL	$V_{SQL} = 1.8$ V to V_{DD}	900	-	1300	μA
I_{PD_SQH}	Pull-down current SQH	$V_{SQH} = SBTH$ to V_{RES}	900	-	1300	μA
V_{BIAS}	Diagnostics Bias Voltage	$I_{SQH} = -1.5$ mA (nominal: 2.0 V)	1.80	-	2.20	V
I_{BIAS}	Diagnostics Bias Current	$V_{SQH} = 0$ V	-7	-	-	I_{PD}
V_{STB}	Short to battery threshold	(Nominal 3.0 V)	2.70	-	3.30	V
V_{STG}	Short to ground threshold	(Nominal 1.0 V)	0.90	-	1.10	V
V_{I_th}	MOS test load voltage detection	-	100	-	300	mV
I_{SRC}	Resistance measurement current source	$V_{DD} = 5.0$ V; $V_{8BUCK} = 7.0$ V to 26.5 V	38	-	42	mA
I_{SINK}	Resistance measurement current sink	-	45	-	55	mA
R_{DSon}	Total high and low side MOS On resistance	High side MOS + Low Side MOS $V_{RES} = 6.9$ V; $I = 1.2$ A @95 °C	-	-	2.0	Ω
R_{DSon}	High side MOS on resistance	$V_{RES} = 35$ V; $I_{VRES} = 1.2$ A; $T_{amb} = 95$ °C	-	-	0.8	Ω
R_{DSon}	Low side MOS on resistance	$V_{RES} = 35$ V; $I_{VRES} = 1.2$ A; $T_{amb} = 95$ °C	-	-	1.2	Ω
I_{DEPL_12A}	Deployment current	MOSI register mode bit D10="0" $R_{LOAD} = 1.7 \Omega$; $V_{RES} = 6.9$ to 35 V	1.20	-	1.47	A
I_{DEPL_175A}		MOSI register mode bit D10="1" $R_{LOAD} = 1.7 \Omega$; $V_{RES} = 12$ to 35 V	1.75	-	2.14	A
I_{LIM}	Low side MOS current limit	$R_{LOAD} = 1.7 \Omega$	2.15	-	3.5	A
R_{L_RANGE}	Load resistance range ⁽²⁾	-	0	-	10.0	Ω

1. Not applicable during a diagnostic.
2. Test conditions for load resistance measurements

$V_{DD} = 4.9 \text{ to } 5.1 \text{ V}$, $V_{8BUCK} = 7.0 \text{ V to } 8.5 \text{ V}$, $T_{amb} = -40 \text{ }^{\circ}\text{C to } +95 \text{ }^{\circ}\text{C}$
Table 8. Satellite interface DC specifications

Symbol	Parameter	Test conditions	Min	Typ	Max	Unit
I_Lim	Current limit	High side short to -0.3 V	(-)75	-	(-)150	mA
		High side short to Battery	-	-	5	mA
		V8BUCK = Vcc=0 measured @ V8BUCK	-	-	-1	mA
Vhdp	High side voltage drop	I=50 mA @ 105 °C; V8BUCK=7.0 V	-	-	1	V
		I=25 mA @ 105 °C; V8BUCK=7.0 V	-	-	0.5	V
IFr	IF/Iout CH3 & CH4	Iout = -50mA	460	-	540	μA
		Iout = -5mA	46	-	54	μA
Itr	Low to high transition current threshold	SPI channel configuration				
		Bit <2:0>≥111	54.00	-	66.00	mA
		Bit <2:0>≥110	43.65	-	53.35	mA
		Bit <2:0>≥101	35.10	-	42.90	mA
		Bit <2:0>≥100	28.80	-	34.20	mA
		Bit <2:0>≥011	24.85	-	29.15	mA
		Bit <2:0>≥010	20.25	-	24.75	mA
		Bit <2:0>≥001	17.10	-	20.90	mA
		Bit <2:0>≥000	14.85	-	18.15	mA
V_CLAMP	IF/Vx CH3 & CH4 clamp voltage	Rext=33.3 kΩ; CHx is shorted to GND	0.95* Vdd	-	1.05* Vdd	V
Ihyst	Current threshold hysteresis	Sink current = Ithr at the output (ICHX). Ihyst=trip point high – trip point low	0.05*Itr	-	0.15*Itr	mA
Vos	Short to BAT feedback current	V(ICHX)-V8BUCK<50mV	-	-	25	mA
Olkg	Output leakage current ICH _x	V=18 V @ pin under test	-	-	1	μA

3.3.2 AC characteristics

$V_{RES} = 6.5$ to 35 V, $V_{DD} = 4.9$ to 5.1 V, $V_{8BUCK} = 7.0$ V to 8.5 V, $T_{amb} = -40$ °C to $+95$ °C

Table 9. AC specification: deployment drivers

Symbol	Parameter	Test conditions	Min	Typ	Max	Unit
t_{POR}	POR de-glitch timer	Timer for V_{RST}	10	-	25	μ s
T_{GLITCH}	De-glitch timer	-	5	-	20	μ s
I_{ON}	Diagnostic current	DEPEN pins asserted; Measured at 150 μ s from falling edge CS_D or CS_A; See Figure 4	0.90	-	-	I_{FINAL}
t_{PULSE}	Pulse stretch timer	See Table 17	0	-	60	ms
t_{P_ACC}	Pulse stretch timer accuracy	-	-20	-	20	%
$t_{DEPLOY-2ms}$	Deployment time	$V_{RES} = 6.9$ to 35 V ⁽¹⁾	2	-	2.5	ms
$t_{DEPLOY-1ms}$	Deployment time	$V_{RES} = 12$ to 40 V ⁽¹⁾	1	-	1.15	ms
t_{FLT_DLY}	Fault detection filter ⁽²⁾	-	10	-	50	μ s
I_{SLEW}	Rmeas current di/dt	10 % - 90 % of I_{SRC}	2	-	8	$\frac{mA}{\mu s}$
t_{R_DLY}	Rmeas current delay	From the falling edge of CS to 10 % of I_{SRC}	-	-	15	μ s
t_{R_WAIT}	Rmeas wait time ⁽²⁾	Wait time before AOUT voltage is stable for ADC reading	-	-	100	μ s
$t_{TIMEOUT}$	MOS diagnostic on-time	-	-	-	2.5	ms
t_{ILIM}	SQL high current protection timer	-	90	-	110	μ s
t_{PROP_DLY}	LS/HS MOS turn off propagation delay ⁽²⁾	Time is measured from the valid LS/HS MOS fault to the LS/HS turn off	-	-	10	μ s

1. Application Information; Test is not performed at high voltage.

2. Design Information Only

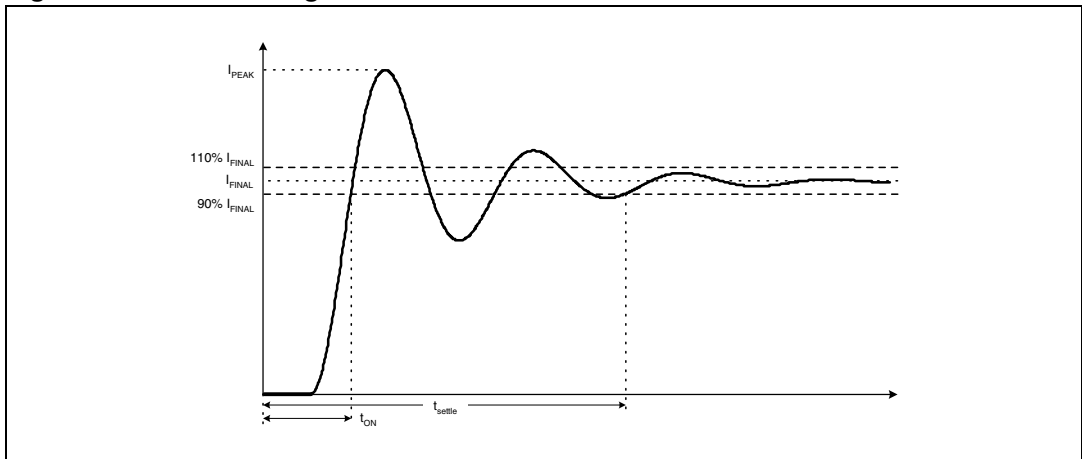
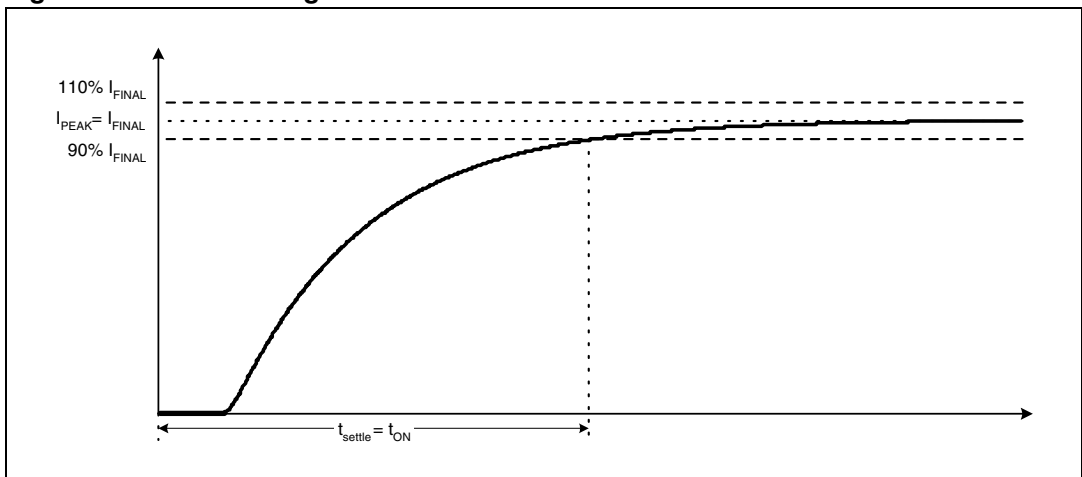
Figure 3. MOS settling time and turn-on time 1**Figure 4. MOS settling time and turn-on time 2**

$V_{DD} = 4.9$ to 5.1 V; $V_{8BUCK} = 7.0$ V to 8.5 V, $T_{amb} = -40$ °C to $+95$ °C

Table 10. AC specifications: satellite

Symbol	Parameter	Test conditions	Min	Typ	Max	Unit
Osc	Internal oscillator frequency	Tested with 12.5k 1% Iref resistor	4.45		5.55	MHz
Mdf	De-glitch filter as a function of protocol speed	Manchester Protocol Excluding Osc tolerance Bit<8:7≥ 00 Bit<8:7≥ 01 Bit<8:7≥ 10 Bit<8:7≥ 11	11.76 %*Bit-Time	-	23.53 % *Bit-Time	µs
Bitr	Minimum frequency operating range (Incoming messages fall within this operating range is guaranteed to be accepted by the IC)	Channel configurations				
		Bit<8:7≥ 00 Test at frq = 52.33 kHz Test at frq =13.32 kHz	13.32	-	52.33	kHz
		Bit<8:7≥01 Test at frq =110.74 kHz Test at frq = 26.32 kHz	26.32	-	110.74	kHz
		Bit<8:7≥10 Test at frq =164.20 kHz Test at frq = 43.50 kHz	43.50	-	164.20	kHz
		Bit<8:7≥11 Test at frq =250.63 kHz Test at frq = 62.66 kHz	62.66	-	250.63	kHz
Bitr	Maximum frequency operating range (Incoming messages fall outside this operating range is guaranteed to be rejected by the IC)	Channel configurations				
		Bit<8:7≥ 00 Test at frq > 59.14 kHz Test at frq <11.99 kHz	11.99	-	59.14	kHz
		Bit<8:7≥01 Test at frq>128.37 kHz Test at frq <23.57 kHz	23.57	-	128.37	kHz
		Bit<8:7≥10 Test at frq>194.93 kHz Test at frq <38.71 kHz	38.71	-	194.93	kHz
		Bit<8:7≥11 Test at frq>309.6 kHz Test at frq <55.37 kHz	55.37	-	309.6	kHz
Idle	Idle time	Manchester	2	-	-	Bit Times
Tdl & Tdh	IFx/Vx delay	Test with12.5k 1% Iref resistor check response from changing between the following current levels. High =0-15 mA, Low = 66 to 150 mA	-	1	-	µs
Tdl - Tdh	IFx/Vx delay time differential	ICH _x outputs with a 500 µs symmetrical pulse in and 500µs out.	-	-	0.3	µs
Fit	Output fault timer	I _{sensor} > I _{lim}	300	-	500	µs

$V_{RES} = 6.5$ to 35 V, $V_{DD} = 4.9$ to 5.1 V. $V_{8BUCK} = 7.0$ V to 8.5 V, $T_{amb} = -40^{\circ}$ C to $+95^{\circ}$ C
 All SPI timing is performed with a 200 pF load on MISO unless otherwise noted.

Table 11. SPI timing

No.	Symbol	Parameter	Min	Typ	Max	Unit
-	f _{op}	Transfer frequency	dc	-	5.50	MHz
1	t _{SCK}	SCLK, SCLK_A Period	181	-	-	ns
2	t _{LEAD}	Enable lead time	65	-	-	ns
3	t _{LAG}	Enable lag time	50	-	-	ns
4	t _{SCLKHS}	SCLK, SCLK_A high time	65	-	-	ns
5	t _{SCLKLS}	SCLK, SCLK_A low time	65	-	-	ns
6	t _{SUS}	MOSI, MOSI_A input setup time	20	-	-	ns
7	t _{HS}	MOSI, MOSI_A input hold time	20	-	-	ns
8	t _A	MISO, MISO_A access time	-	-	60	ns
9	t _{DIS}	MISO, MISO_A disable time ⁽¹⁾	-	-	100	ns
10	t _{VS}	MISO, MISO_A output valid time	-	-	66	ns
11	t _{HO}	MISO, MISO_A output hold time ⁽¹⁾	0	-	-	ns
12	t _{RO}	Rise Time (Design Information)	-	-	30	ns
13	t _{FO}	Fall Time (Design Information)	-	-	30	ns
14	t _{CSN}	CS_A, CS_D, CS_S negated time	640	-	-	ns

1. Parameters t_{DIS} and t_{HO} shall be measured with no additional capacitive load beyond the normal test fixture capacitance on the MISO pin. Additional capacitance during the disable time test erroneously extends the measured output disable time, and minimum capacitance on MISO is the worst case for output hold time.

Figure 5. SPI timing diagram

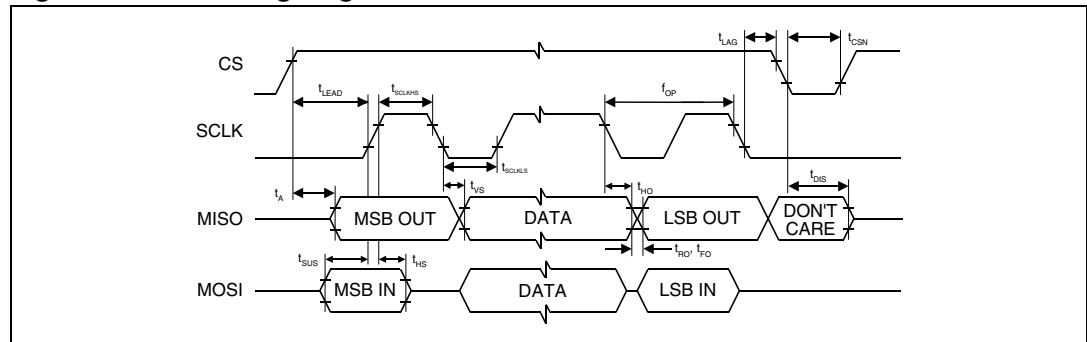
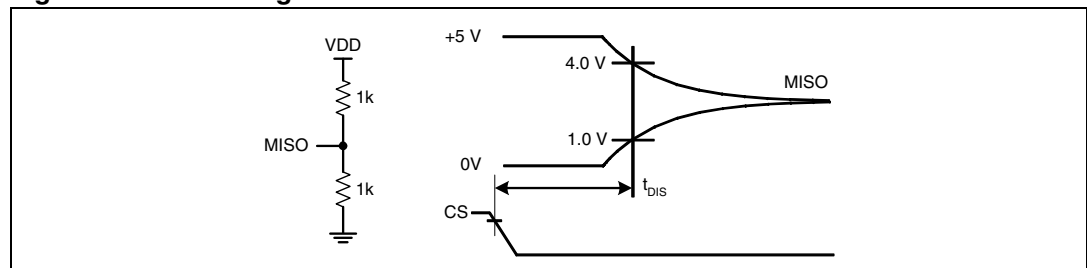

Figure 6. SPI timing measurement



4 Functional description

4.1 Overview

L9658 is an integrated circuit to be used in air bag systems. Its main functions include deployment of air bags, switched-power sources to satellite sensors, diagnostics of SDM (Sensing Deployment Module) and arming inputs. L9658 supports 8 deployment loops, 4 satellite-sensor interfaces, and SPI arming inputs.

4.2 Power on reset (POR)

L9658 has a power on reset (POR) circuit, which monitors V_{DD} voltage. When V_{DD} voltage falls below V_{RST} for longer than or equal to t_{POR} , all outputs are disabled and all internal registers are reset to their default condition.

When V_{DD} falls below V_{RST_L} , all outputs are disabled and all internal registers are reset to their default condition. No delay filter shall be used along with V_{RST_L} threshold.

If V_{DD} voltage falls below V_{RST} for less than t_{POR} , operation shall not be interrupted.

When V_{DD} rises above V_{RST} , the outputs are enabled. Before V_{DD} reaches V_{RST} and during t_{POR} , none of the outputs turn on.

4.3 RESETB

RESETB pin is active low. The effects of RESETB are similar to those of a POR event, except during a deployment. When L9658 has a deployment in-progress, it ignores RESETB signal.

However, it shall shut itself down as soon as it detects a POR condition. When the deployment is completed and RESETB signal is asserted, the device disables its outputs and reset its internal registers to their default states.

A de-glitch timer is provided to RESETB pin. The timer protects this pin against spurious glitches. UT48 neglects RESETB signal if it is asserted for shorter than t_{GLITCH} . RESETB has an internal pull-up in case of an open circuit. This pin has a de-glitch timer

4.4 MSG

MSG pin is used to reflect FIFO status. Its polarity can be configured and also the strategy of activation.

Polling mode: Message pin shall be active as soon as one of the 4 FIFO will be not empty and it will be inactive when all 4 FIFO will be empty. A microcontroller can periodically monitor the status of line to understand there are data received from satellite. Interrupt

mode: Message pin shall be active as soon one of the 4 FIFO will be not empty and it will be inactive when a spi communication on CS_S interface starts. At the end of the SPI communication it shall be active if one of the 4 FIFO will be not empty. Otherwise shall be kept inactive. A microcontroller can wait until an edge is present on the line and manage the data available in the FIFO.

4.5 IREF

I_{REF} pin shall be connected to V_{DD} supply through a resistor, R_{IREF} . When the device detects the resistor on I_{REF} pin is larger than R_{IREF_H} or smaller than R_{IREF_L} , it goes in reset condition. All outputs are disabled and all internal registers are reset to their default conditions.

4.6 Loss of ground

When GND pin is disconnected from PC-board ground, L9658 goes in reset condition. All outputs are disabled and all internal registers are reset to their default conditions. A loss of power-ground (GND0 – GND7) pin/s disables the respective channel/s. In other words, the channel that loses its power ground connection will not be able to deploy. The rest of the device is not affected by a loss of power-ground condition.

A_{OUT_GND} pin is a reference for A_{OUT} pin. When A_{OUT_GND} loses its connection the reset as well.

4.7 Deployment and reset

The following conditions reset and terminate deployments:

- Power On Reset (POR)
- IREF resistance is larger than R_{IREF_H} or smaller than R_{IREF_L}
- Loss of ground condition on GND pin

The following conditions are ignored when it has a deployment in-progress:

- RESETB
- Valid soft reset sequences

4.8 Serial peripheral interface (SPI)

The device contains a serial peripheral interface consisting of Serial Clock (SCLK, SCLK_A), Serial Data Out (MISO, MISO_A), Serial Data In (MOSI, MOSI_A), and two Chip Selects (CS_A, CS_D and CS_S). This device is configured as an SPI slave. The idle state of the communication, Serial Clock (SCLK, SCLK_A) should be low state.

Figure 7. SPI block diagram

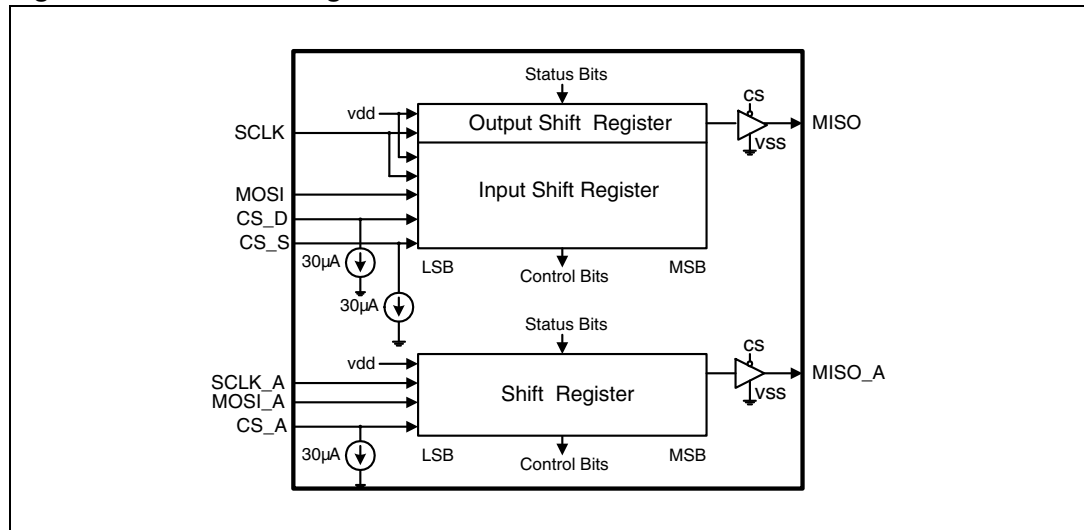

L9658 has a counter to verify the number of clocks in SCLK and SCLK_A. If the number of clocks in SCLK is not equal to 16 clocks while CS_D is asserted, it ignores the SPI message and send a SPI fault response. If the number of clocks in SCLK is not equal to 64 clocks while CS_S is asserted, it ignores the entire SPI message and push the Bad SPI Bit Count fault code into the FIFO. If the number of clocks in SCLK_A is not a multiple of 8, it ignores the command in the arming shift register. Otherwise, the device latch-in the command.

Figure 8. Arming daisy-chain configuration

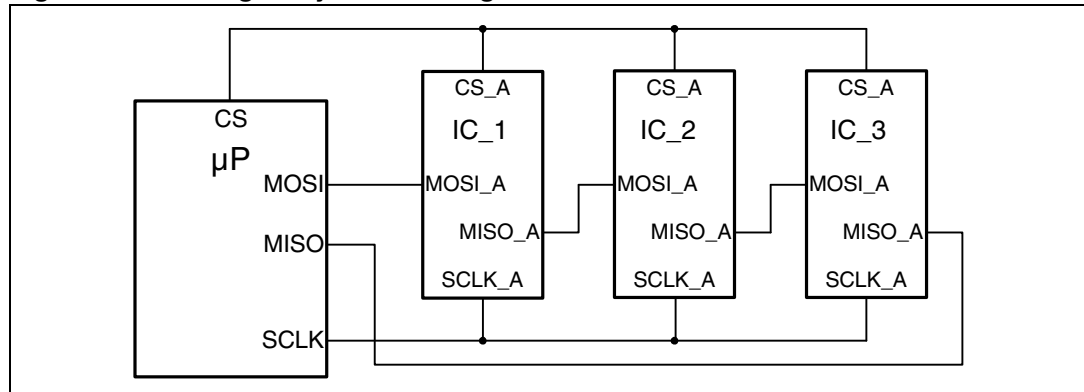

Arming SPI interface is based on 8-bit data transfer. The device is capable to receive a multiple of 8-bit commands. The first byte of data coming out of MISO_A will be the arming status bits. The subsequent bits will be the arming command bits received through MOSI_A pin. Refer to below figure for an example of arming SPI transmission. This is an example of arming SPI transmission based on the daisy-chain configuration.

In case of daisy chain connection for Arming SPI, device works as following:

All devices IC_1, IC_2, IC_3 shifted out data on the falling edge of SCLK_A for the first 8 bits and shifted out data on the rising edge of SCLK_A for the bits after 8bits. therefore µP, IC_3, IC_2 shall strobe 24bits on rising edge of SCLK_A, the first 8 bits are produced (by IC_3, IC_2, IC_1 respectively) on the falling edge of SCLK_A. the remaining 16 bits are shifted out on the rising edge.

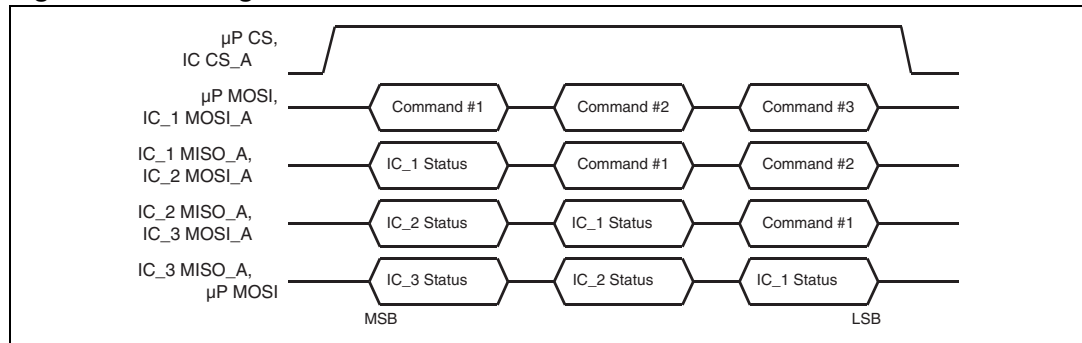
Figure 9. Arming SPI transmission

4.8.1 Chip select (CS_A, CS_D, CS_S)

Chip-select inputs select L9658 for serial transfers. CS_A is independent to CS_D and CS_S.

CS_A can be asserted regardless of CS_D and CS_S. However, either CS_D or CS_S can be asserted at any given time. If both CS_D and CS_S inputs are selected simultaneously, the device ignores MOSI command. When chip-select is asserted, the respective MISO/MISO_A pin is released from tri-state mode, and all status information is latched in the SPI shift register. While chip-select is asserted, register data is shifted into MOSI/MOSI_A pin and shifted out of MISO/MISO_A pin on each subsequent SCLK/SCLK_A. When chip-select is negated, MISO/MISO_A pin is tri-stated. To allow sufficient time to reload the registers; chip-select pin shall remain negated for at least t_{CSN} .

Chip-select is also immune to spurious pulses of 50 ns or shorter (MISO/MISO_A may come out of tri-state, but no status bits is cleared and no control bits is changed).

Chip-select inputs have current sinks on the pins, which pull these pins to the negated state when an open circuit condition occur. These pins have TTL level compatible input voltages allowing proper operation with microprocessors using a 3.3 to 5.0 V supply.

4.8.2 Serial clock (SCLK, SCLK_A)

SCLK/SCLK_A input is the clock signal input for synchronization of serial data transfer. This pin has TTL level compatible input voltages allowing proper operation with microprocessors using a 3.3 to 5.0 V supply. When chip select is asserted, both the SPI master and this device shall latch input data on the rising edge of SCLK/SCLK_A. L9658 shift data out on the falling edge of SCLK/SCLK_A. The SCLK/SCLK_A must be taken in idle state (LOW) when the CS_A, CS_D, CS_S are in idle state (LOW).^(a)

4.8.3 Serial data output (MISO, MISO_A)

MISO/MISO_A output pin shall be in a tri-state condition when chip select is negated. When chip select is asserted, the MSB is the first bit of the word/byte transmitted on MISO/MISO_A and the LSB is the last bit of the word/byte transmitted. This pin supplies a rail to rail output, so if interfaced to a microprocessor that is using a lower VDD supply, the appropriate microprocessor input pin shall not sink more than IOH (min) and shall not clamp the MISO/MISO_A output voltage to less than VOH (min) while MISO/MISO_A pin is in a logic "1" state.

a. Only in daisy chain, it is needed to guarantee on SCLK_A a clock skew of 3ns maximum between any devices.

4.8.4 Serial data input (MOSI, MOSI_A)

MOSI/MOSI_A input takes data from the master processor while chip select is asserted.

The MSB shall be the first bit of each word/byte received on MOSI/MOSI_A and the LSB shall be the last bit of each word/byte received. This pin has TTL level compatible input voltages allowing proper operation with microprocessors using a 3.3 to 5.0 V supply.

4.9 Deployment drivers

The on-chip deployment drivers are designed to deliver 1.2 A (min) at 6.9 V VRES. Deployment current is be 1.2 A (min) for 2 ms (min). The high side driver survives deployment with 1.47 A, 35 V at VRES and SQL is shorted to ground for 2.5ms. Minimum load resistance is 1.7. At the end of a deployment, a deploy success flag is asserted via SPI. Each VRES and GND connection are used to accommodate 8 loops that can be deployed simultaneously.

Upon receiving a valid deployment condition, the respective SQH and SQL drivers are turned on. SQH and SQL drivers are also turned on momentarily during a MOS diagnostic. Otherwise, SQH and SQL are inactive under any normal, fault, or transient conditions. Upon a successful deployment of the respective SQH and SQL drivers, a deploy command success flag is asserted via SPI. Refer to "deployment sequence" figure for the valid condition and the deploy success flag timing.

Figure 10. Deployment drivers diagram

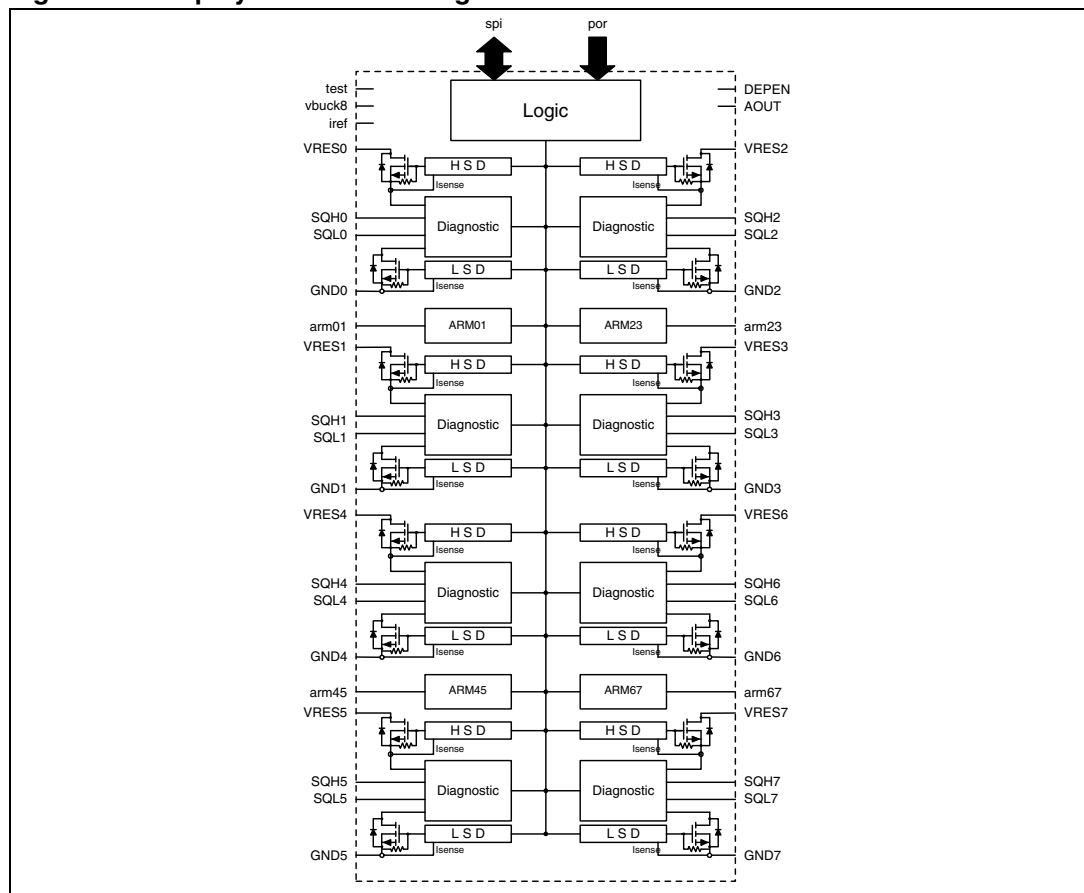

The following power-up conditions is considered as normal operations. VRES input can be connected to either a power supply output or an ignition voltage. VDD is connected to 5 V output of power supply. When VRES is connected to the power supply, VDD voltage will reach its regulation voltage before VRES voltage is stabilized. In this condition, the device has the control of its internal logic and that prevent an inadvertent turn-on of the drivers.

When VRES is connected to the ignition, VRES voltage will be stabilized before VDD reaches its regulation voltage. In this condition, all drivers are inactive. A pull-down on the gates of high side drivers (SQH) is provided to prevent these drivers from momentarily turning-on. Any loop driver fault conditions do not turn on the SQH and SQL drivers. Only a valid deployment condition can turn on the respective SQH and SQL drivers. Refer to section for valid deployment conditions.

4.9.1 Arming interface

The arming interface is used as a fail-safe to prevent inadvertent airbag deployment. Along with deployment command, these signals provide redundancy. Pulse stretch timer is provided for each channel/loop. Either ARM signal or deployment command shall start the pulse stretch timer.

Arming interface has a dedicated 8-bit SPI interface.

When CS_A is negated, L9658 latch ARM signal from the shift register and start the pulse stretch timer for the respective channel/s. The device can deploy a channel, ONLY when DEPEN is asserted and any of the following conditions are satisfied:

- the respective deployment command is sent during a valid pulse stretch timer, which initiated by ARM signal
- the respective SPI ARM command is sent during a valid pulse stretch timer, which initiate by deployment command

During a deployment, the device turn on the respective high side (SQH) and low side (SQL) drivers for duration of t_{DEPLOY} . When a deployment is initiated, it cant be terminated, except during a reset event.

Figure 11. Deployment sequence

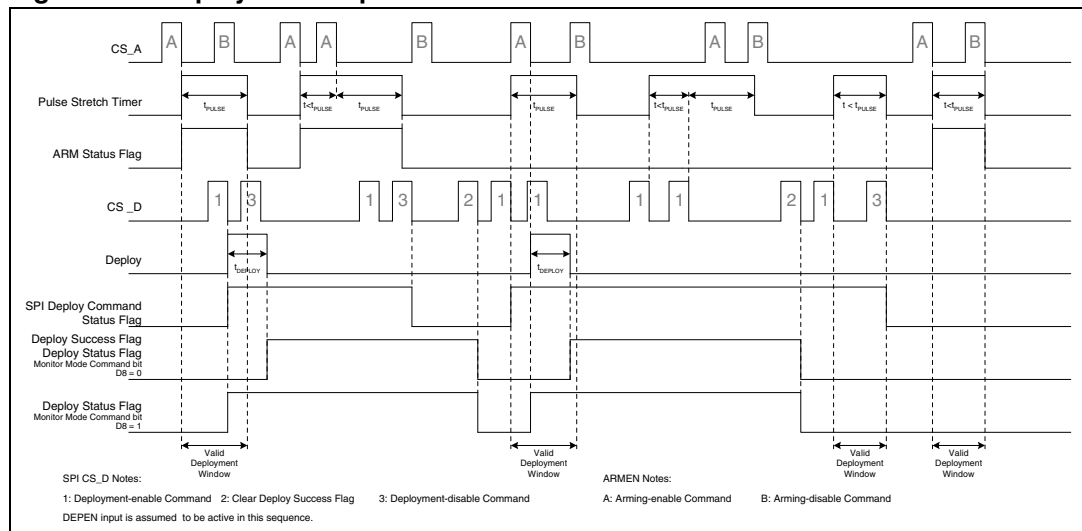

When a deployment-enable command is sent through SPI, the pulse stretcher shall be initiated immediately following the falling edge of CS_D. When another deployment-enable

command is sent before the timer for the previous command expired, the timer is refreshed. Sending a deployment-disable command will terminate the pulse stretch timer operation. ONLY a timer operation started by a deployment-enable command can be terminated. A deployment-en/disable command does not affect the timer operation started by arming signal.

When an arming-enable command is sent through SPI, the pulse stretcher is initiated immediately following the falling edge of CS_A. When another arming-enable command is sent before the timer for the previous command expired, the timer is refreshed. Sending an arming disable command terminate the pulse stretch timer operation. ONLY a timer operation started by an arming-enable command can be terminated. An arming-en/disable command does not affect the timer operation started by a valid deployment command.

Figure 12. Deployment flow chart

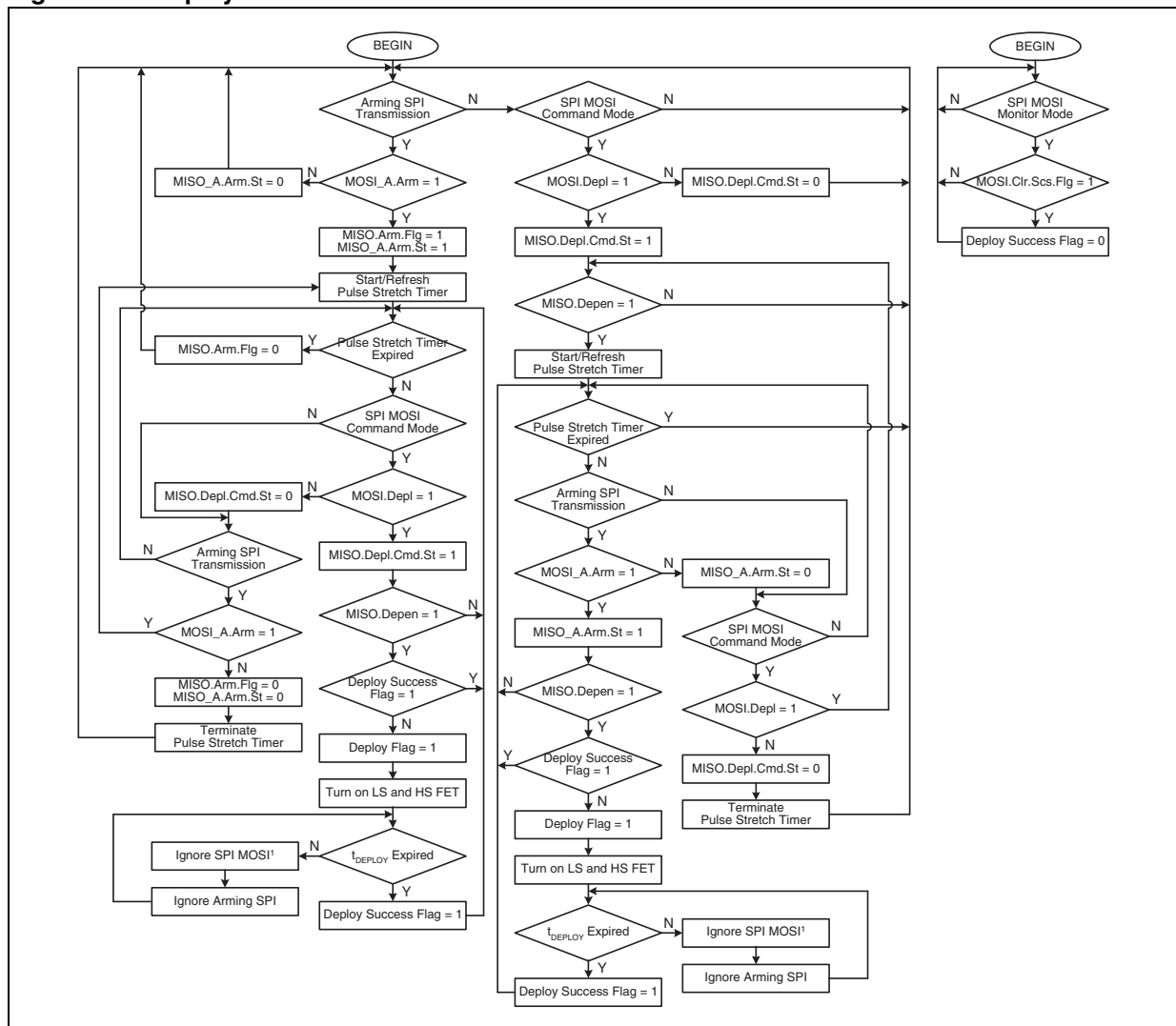

Note: *MOSI Register Mode: ignored. Next MISO: SPI fault response*
MOSI Command Mode: execute for channels NOT in deployment, NO effect to deploying channel. Next MISO: Command mode response
MOSI Diagnostic Mode: ignored. Next MISO: SPI fault response
MOSI Monitor Mode: execute for all channels. Next MISO: Status response

During the deployment, L9658 turn on the respective high (SQH) and low side (SQL) drivers for tDEPLOY. Once deployment is initiated it can not be terminated. When a channel is in deployment, this particular channel shall only act upon certain SPI messages. These SPI messages and their responses are summarized in below table. The rest of the channels shall resume their operations and respond to specific SPI commands.

During a deployment, the device ignores arming commands. and does not refresh or terminate the pulse stretch timer when it receives an arming command.

Table 12. SPI transmission during a deployment

SPI MOSI	SPI MISO ⁽¹⁾	Notes
Register mode	SPI fault response	MOSI register mode message shall be ignored
Command mode	Command mode	Execute for channels not in deployment; no effect to deploying channel
Diagnostic mode	SPI fault response	MOSI diagnostic mode message shall be ignored
Monitor mode	Status response	Execute for all channels

1. SPI MISO sent in the next SPI transmission.

4.10 DEPEN

DEPEN is a deployment enable input, which is an active high input. When this pin is asserted, L9658 is able to turn on its high and low side drivers upon receiving a valid deployment command or a MOS diagnostic request. DEPEN can not interrupt a deployment that is already in-progress.

When DEPEN is negated, it inhibits the low side and the high side MOS from turning on (inhibit the deployment). When a MOS diagnostic is requested, the device executes the diagnostic even without the ability to turn on the MOS. It set the proper SPI threshold bits. SPI remains functional while this pin is pulled low.

When DEPEN is negated, SPI deploy command is prevented from initiating the pulse stretch timer. Regardless of DEPEN, SPI deploy command status bits reports the state of SPI deploy command bits sent in the previous SPI transfer. This feature is required so that the processor can diagnose SPI deploy command bits with DEPEN negated.

Regardless of DEPEN, arming signal is able to initiate the pulse stretch timer. This feature will be used for the processor to diagnose the arming signal.

When the pulse stretch timer has been running, changes in the state of DEPEN does not affect the pulse stretch timer. The pulse stretch timer is not affected regardless of the pulse stretch timer being started by an arming signal or a SPI deploy command.

A de-glitch timer is provided to DEPEN pin. The timer protects this pin against spurious glitches. The device neglects DEPEN signal if it is asserted/negated for shorter than t_{GLITCH} .

4.10.1 Deployment driver diagnostic

L9658 is able to perform a short to battery, a short to ground, a resistance measurement and a MOS diagnostics on its deployment drivers. A short to ground and an open circuit conditions are distinguished using a resistance measurement. Here below is shown the diagram of deployment driver diagnostic.

The diagnostic is performed when a valid SPI command is received. Each current sources (I_{SRC} and I_{BIAS}) and current sinks (I_{SINK} , I_{PD_SQH}) are turn on or off by a SPI command. I_{PD_SQH} is turned on when I_{BIAS} is turned on. This pull-down (I_{PD_SQH}) is used to deplete the charge left on the SQH and SQL capacitors. IPD is permanently connected to SQL. This current sink pull-down SQL pin during an open circuit condition.

Diagnostic current source or sink and comparator or amplifier are independent. It is possible to turn on or off the current source or sink on a specific channel, while monitoring the comparator or amplifier on a different channel. This feature is used to run a short between loop diagnostic.

Figure 13. Deployment driver diagnostic diagram

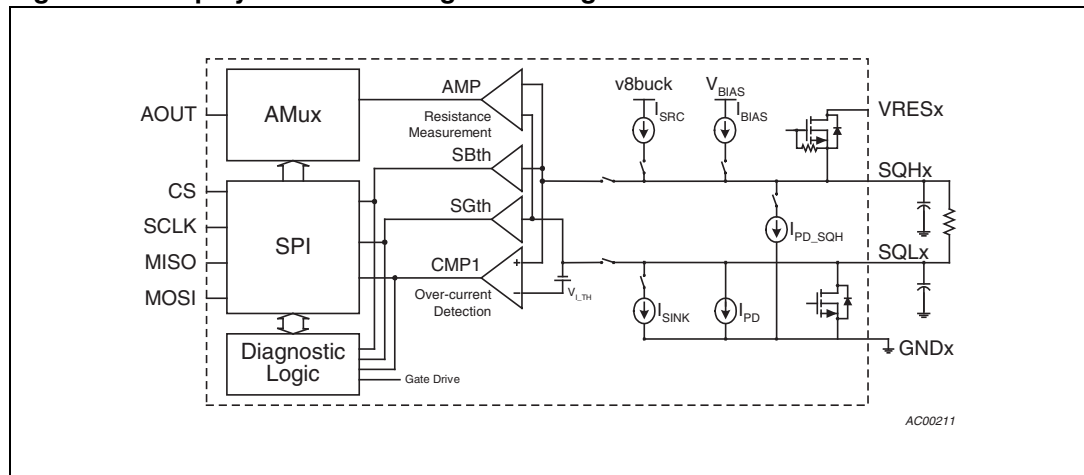

4.10.2 Continuity diagnostic

A continuity diagnostic includes a short to battery, a short to ground and an open circuit diagnostics.

During a continuity diagnostic, IBIAS is switched on. On a normal loading condition, SQH voltage is below SBTH threshold and SQL voltage will be above SGTH threshold.

Figure 14. Continuity diagnostic flow chart

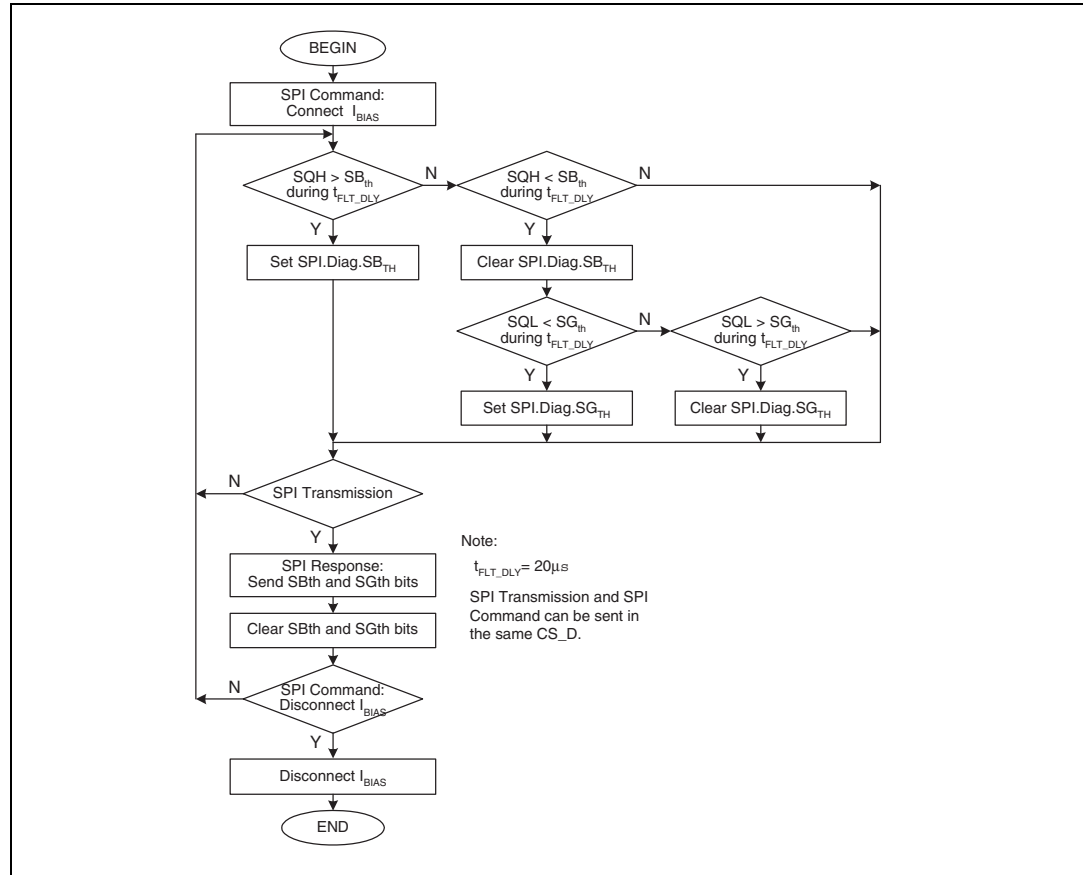

4.10.3 Short to battery

A short to battery condition will be detected when the voltage on SQH is greater than SBTH threshold voltage.

4.10.4 Short to ground and open circuit

A short to ground or an open circuit conditions are detected when the voltage on SQL is less than SGTH threshold voltage. A resistance measurement is utilized to differentiate between a short to ground or an open circuit conditions.

4.10.5 Resistance measurement

During a resistance measurement, both ISRC and ISINK are switched on. An analog voltage on A_{OUT} pin is provided. A_{OUT} pin is a 5 V analog pin, which will be connected to the ADC input of a processor. This pin provides the resistance-measurement voltage, which correspond to the voltage difference across SQH and SQL. According to the following formula:

$$V_{aout} = V_{DD}/10 + R_{sqiib} \cdot I_{src} \cdot 10$$

The accuracy in the range of R_{sqiib} is classified as followings:

$$\begin{aligned} 0 < R_{sqiib} \leq 3.5 \Omega & \quad \pm 95 \text{ mV} \\ 3.5 < R_{sqiib} \leq 10 \Omega & \quad \pm 5 \% \end{aligned}$$

A low pass filter (10 kΩ + 330 pF) is recommended in order to cancel noise caused by internal offset compensation.

Figure 15. Resistance measurement flow chart

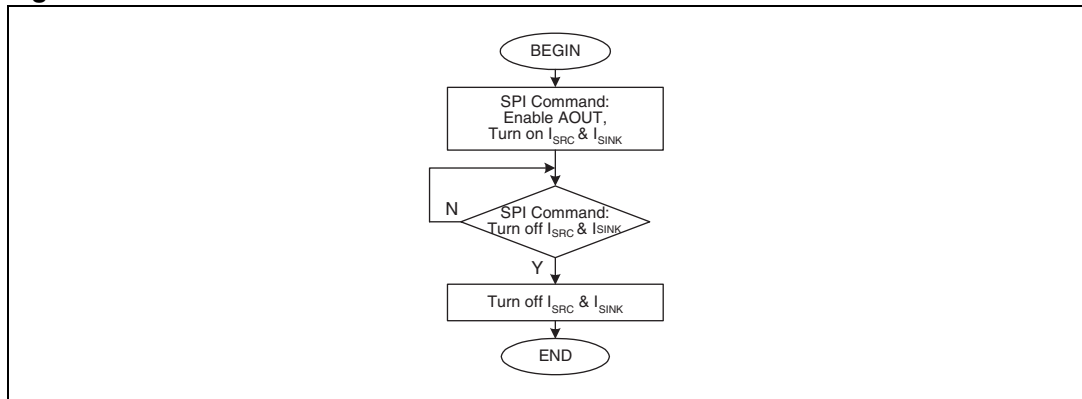

4.10.6 MOS diagnostics

During diagnostic, IBIAS is connected to SQH pin. In a normal condition, SQH voltage is below SB_{TH} and SQL voltage will be higher than SG_{TH}. Prior to turning on the MOS, the processor is expected to check for a short to battery and a short to ground fault. This step is intended to prevent a large amount of current flowing through the MOS. Also, this step is intended to precondition SQH and SQL pins prior to diagnostics. DEPEND pin is asserted in order to turn on the low or high side driver. If DEPEND is negated during diagnostic, the MOS is not turned on and a fail MOS diagnostic is expected.

4.10.7 Low side MOS diagnostic

When L9658 receives a SPI command to initiate the low side driver diagnostic, verification of following conditions are done before turning on the low side driver:

- V_{SQL} greater than SG_{TH} threshold voltage
- V_{SQH} less than SB_{TH} threshold voltage

If both conditions above are satisfied, execution of low side driver diagnostic is performed. Otherwise, the low side MOS diagnostic request is ignored and both bit D13 and bit D7 in SPI diagnostic mode response are set. Upon detection of the following conditions, the

device turns the low side driver off and terminate the diagnostic within the specified time, t_{PROP_DLY} .

- V_{SQL} less than SG_{TH} threshold voltage
- $(V_{SQHx} - V_{SQLx})$ greater than V_{I_TH}
- V_{SQH} greater than SB_{TH} threshold voltage

The state of each comparator above is reported through SPI. When the device detects one of the above conditions, the respective SPI status bit to indicate the condition is set. Any of the above conditions will be considered as normal in a low side MOS diagnostic.

The low side driver is turned off when $t_{TIMEOUT}$ is expired. A fault detection filter, t_{FLT_DLY} , is provided to protect against short-transients on SQH and SQL pins.

Figure 16. Low side diagnostic flow chart

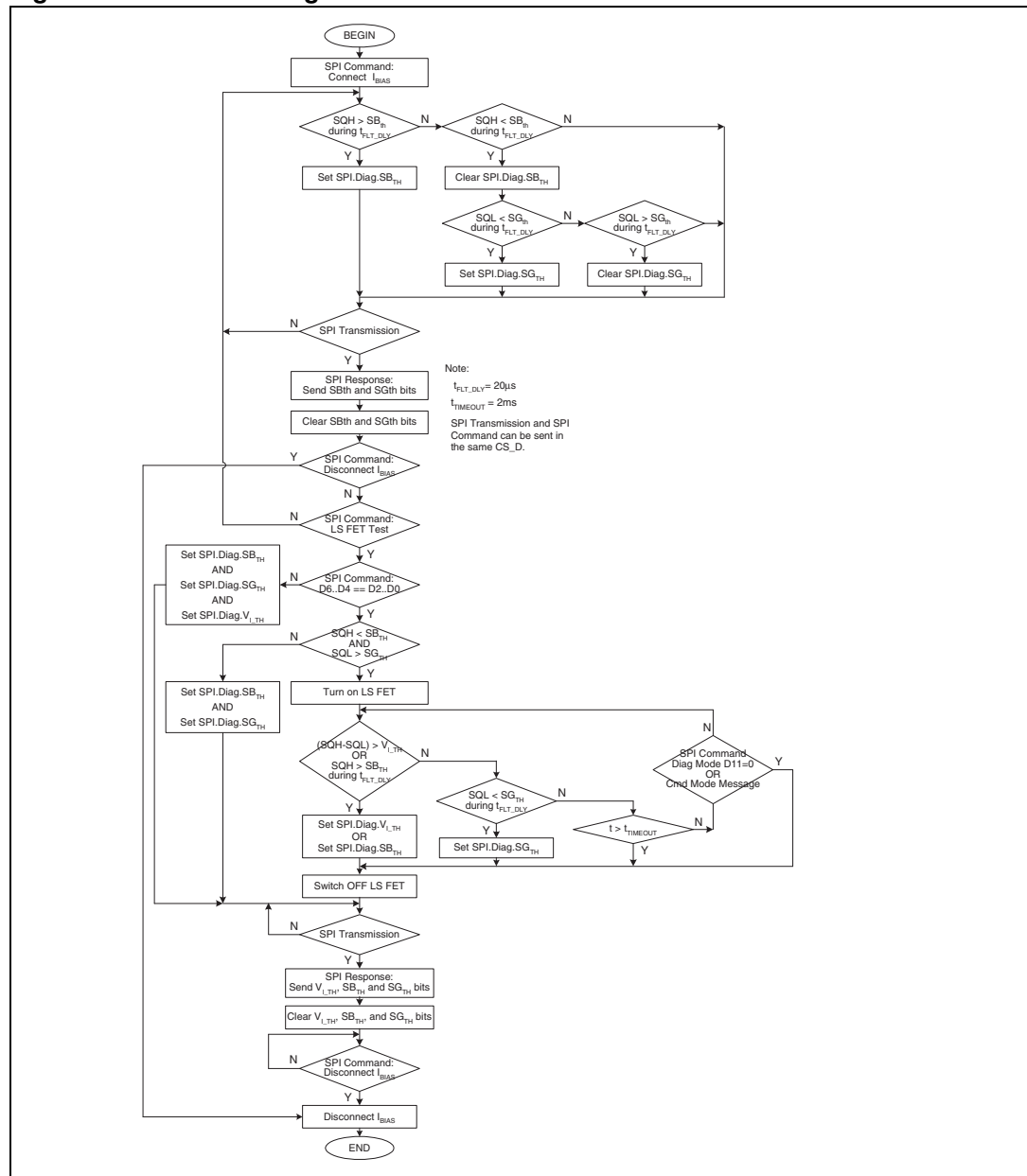

4.10.8 High side MOS diagnostic

When L9658 receives a SPI command to initiate the high side MOS diagnostic, the following conditions are verified before turning on the high side MOS:

- V_{SQL} greater than SG_{TH} threshold voltage
- V_{SQH} less than SB_{TH} threshold voltage

If both conditions above are satisfied, the high side MOS diagnostic is executed. Otherwise, it is ignored and both bit D13 and bit D7 in SPI diagnostic are set.

Upon detection of the following conditions, the high side driver is turned off and the diagnostic, within the specified time, t_{PROP_DLY} , is terminated

- V_{SQH} greater than SB_{TH} threshold voltage
- $(V_{SQHx} - V_{SQLx})$ greater than V_{I_TH}
- V_{SQL} less than SG_{TH} threshold voltage

The state of each comparator above is reported through SPI. When L9658 detects one of the above conditions, it sets the respective SPI status bit to indicate the condition. Any of the above conditions will be considered as normal in a high side MOS diagnostic.

The high side driver is turned off when $t_{TIMEOUT}$ is expired. A fault detection filter, t_{FLT_DLY} , is provided to protect against short-transients on SQH and SQL pins.

4.10.9 Loss of ground

When any of the power grounds (GND0 – 7) are lost, no deployment can occur to the respective deployment channels. A loss of ground condition on one or several channels will not affect the operation of the remaining channels.

When a loss of ground condition occurs, the source of the low side MOS will be floating. In this case, no current will flow through the low side driver.

This condition will be detected as a fault by a low side MOS diagnostic. Also, the resistance measurement result will be on the low end of the resistance range.

Figure 17. High side driver diagnostic flow chart

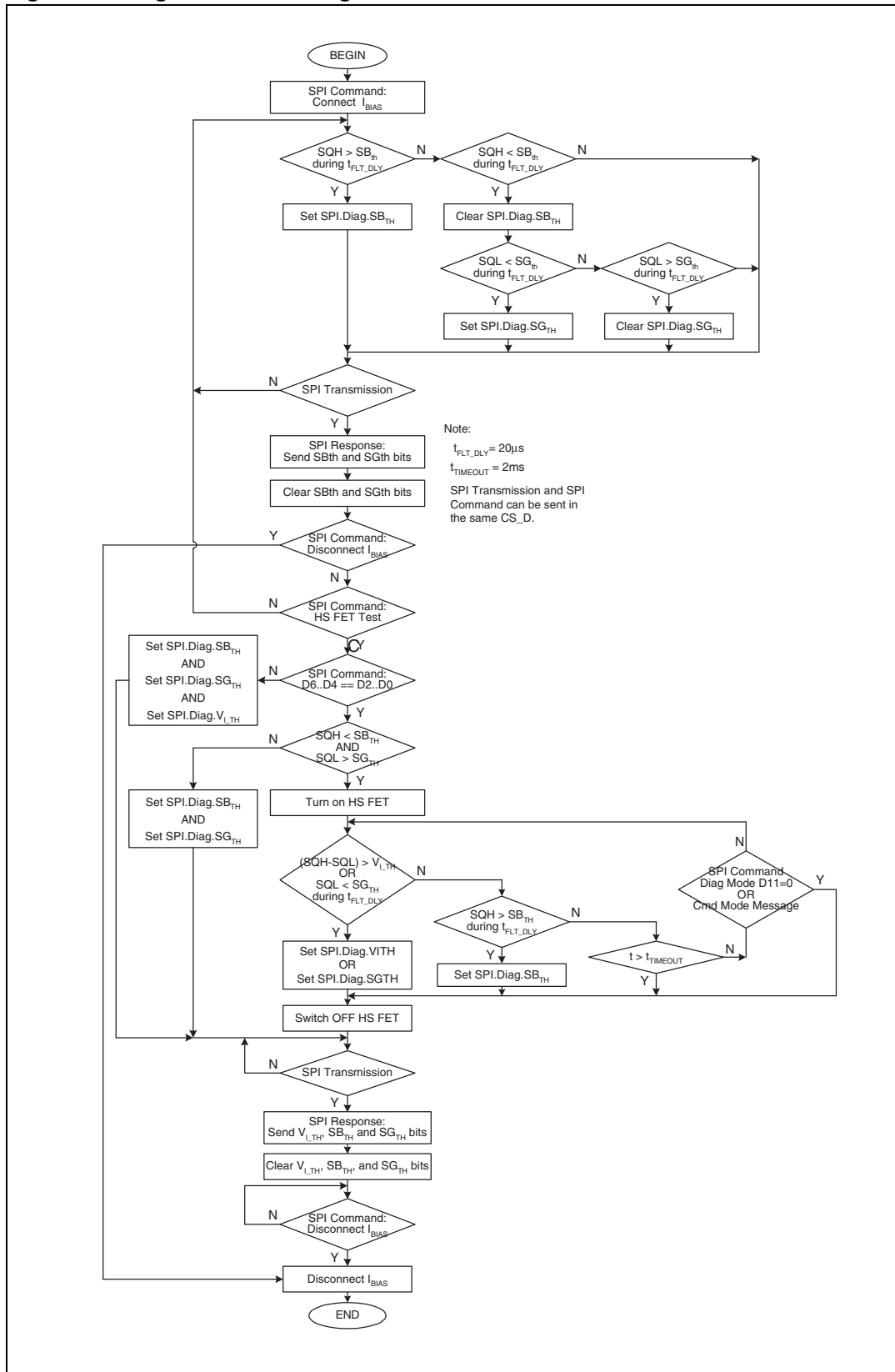

4.11 Deployment driver SPI bit definition

The SPI provides access to read/write to the registers internal to the device, which responses to various deployment driver commands summarized in table below.

L9658 response to the previous command is sent in the next valid CS_D.

Table 13. Deployment driver SPI response

Mode bits		MOSI command	Mode bits			MISO response
D15	D14		D15	D14	D13	
0	0	Register Mode	0	0	0	Register Mode
0	1	Command Mode	0	1	0	Command Mode
1	0	Diagnostic Mode	1	0	X	Diagnostic Mode
1	1	Monitor Mode	1	1	0	Status Response
X	X	SPI Transmission Fault	1	1	1	SPI Fault Response

4.11.1 Deployment driver MOSI bit definition

Table 14. MOSI bit layout

MSB															LSB
D15	D14	D13	D12	D11	D10	D9	D8	D7	D6	D5	D4	D3	D2	D1	D0

MOSI mode bits are defined as shown in below table.

Table 15. MOSI mode bits definition

Bit D15	Bit D14	Description
0	0	Register Mode
0	1	Command Mode
1	0	Diagnostic Mode
1	1	Monitor Mode

4.11.2 Deployment driver register mode

Register Mode message are defined here below.

Table 16. MOSI register mode message definition

Bit	State	Description
D15	0	Mode bits
D14	0	
D13		Odd parity
D12	0	Read (default)
	1	Write
D11	0	Pulse Stretch Timer Period
	1	Soft Reset Sequence
D10	0	Deployment Condition: I_{DEPLOY_12A} and t_{DEPLOY_2ms}
	1	Deployment Condition: I_{DEPLOY_175A} and t_{DEPLOY_1ms}
Bit	State	Description
D9	-	Pulse Stretch timer (see table 17)
D8	-	
D7	-	Soft Reset Sequence
D6	-	
D5	-	
D4	-	
D3	-	
D2	-	
D1	-	
D0	-	

Odd parity check includes all 16 bits. "Don't care" bit is included in the parity check as well.

When bit D12 is set to '0,' device ignores bit D11 through bit D0. This is a read request. In the next valid CS_D, a register mode response will contain the pulse stretch timer register.

If bit D12 is set to '1,' bit D11 determines whether the message is intended to program the duration of the pulse stretch timer or to address the soft reset sequence.

When bit D11 is set to '0,' device ignores bit D7 through bit D0. When bit D11 is set to '1,' bit D9 and bit D8 will be ignored.

Bit D10 is used to select between two deployment conditions. When bit D10 is set to 0, deployment events on all channels shall have the deployment current of I_{DEPL_12A} and the deployment period of t_{DEPL_2ms} . When bit D10 is set to 1, deployment events on all channels shall have the deployment current of I_{DEPL_175A} and the deployment period of t_{DEPL_1ms} . The default state of this bit shall be %0.

Bit D9 and bit D8 are used to set the period of pulse stretch timer.

The device have 8 independent timers. Either a valid arming signal or a SPI deployment command is able to start the pulse stretch timer. These bits will set the timer duration. These values default to %00 after a POR event.

Table 17. Pulse stretch timer

Bit D9	Bit D8	Stretch period (ms)
0	0	7.5
0	1	15
1	0	30
1	1	60

Bit D7 through bit D0 will be used for a soft reset sequence. The soft reset for the deployment driver is achieved by writing \$AA and \$55 within two subsequent 16-bit SPI transmissions. If he sequence is broken, the processor will be required to re-transmit the sequence.

L9658 does not reset if the sequence is not completed within two subsequent 16-bit SPI transmissions. This soft reset function is available only to deployment drivers.

When soft reset command is received, the deice reset its deployment driver’s internal logic and timer. The effects of soft reset to the deployment driver is the same as ones of POR event, except MISO response.

During a deployment, soft reset sequence is ignored.

4.11.3 Deployment driver command mode

Command Mode message is defined as shown below.

Table 18. MOSI command mode message definition

Bit	State	Description
D15	0	Mode Bits
D14	1	
D13		Odd Parity
D12	-	Don't Care
D11	-	Don't Care
D10	-	Don't Care
D9	-	Don't Care
D8	-	Don't Care
D7	0	Channel 7 Idle (default)
	1	Deploy Channel 7
D6	0	Channel 6 Idle (default)
	1	Deploy Channel 6

Table 18. MOSI command mode message definition (continued)

Bit	State	Description
D5	0	Channel 5 Idle (default)
	1	Deploy Channel 5
D4	0	Channel 4 Idle (default)
	1	Deploy Channel 4
D3	0	Channel 3 Idle (default)
	1	Deploy Channel 3
D2	0	Channel 2 Idle (default)
	1	Deploy Channel 2
D1	0	Channel 1 Idle (default)
	1	Deploy Channel 1
D0	0	Channel 0 Idle (default)
	1	Deploy Channel 0

Odd parity check includes all 16 bits. “Don’t care” bit is included in the parity check as well.

Bit D7 to bit D0 are used to start the deployment or the pulse stretch timer. L9658 provides an independent timer for each channel. When any of these bits are set to ‘1,’ device starts the deployment or the pulse stretch timer for the respective channels.

If any of these bits are set to ‘0’ when the pulse stretch timer is still active, the pulse stretch timer for the respective channels is terminated. Once deployment is initiated, can not be terminated.

During a deployment, any commands directed to the channel that are in deployment are ignored.

4.11.4 Deployment driver diagnostic mode

Diagnostic mode message are defined as shown here below.

Table 19. MOSI diagnostic mode message definition

Bit	State	Description
D15	1	Mode Bits
D14	0	
D13		Odd Parity
D12	0	Read Diagnostic Mode Response (default)
	1	Write Diagnostic Mode Command
D11	0	MOS Diagnostic Disable (default)
	1	MOS Diagnostic Enable
D10	0	LS MOS Diagnostic Enable
	1	HS MOS Diagnostic Enable

Table 19. MOSI diagnostic mode message definition (continued)

Bit	State	Description
D9	0	Diagnostic Current Disable (default)
	1	Diagnostic Current Enable
D8	0	Diagnostic Bias Current, I_{BIAS} , Enable
	1	Resistance Measurement Current, I_{SRC} , Enable
D7	0	AOUT Disable (default)
	1	AOUT Enable
D6	-	AOUT/Comparator Channel Select
D5	-	
D4	-	
D3	0	AOUT: Resistance Measurement (default)
	1	AOUT: Calibration
D2	-	Diagnostic Current: Channel Select
D1	-	
D0	-	

Odd parity check includes all 16 bits. “Don’t care” bit is included in the parity check as well.

When bit D12 is set to ‘1,’ device executes bit D12 through bit D0. Otherwise, bit D12 through bit D0 is ignored. Diagnostic Mode Response is sent in the subsequent SPI transmission regardless of bit D12.

The diagnostic currents comprise of diagnostic bias current (I_{BIAS}) and resistance measurement current (I_{SRC}). Diagnostic bias current is used to run continuity tests, e.g. short to battery, short to ground, and open circuit tests. During a resistance measurement, I_{SRC} and I_{SINK} is turned on.

I_{SRC} and I_{SINK} are turned on when bit D8 is ‘1,’ bit D9 is ‘1,’ bit D11 is ‘0,’ and bit D12 is ‘1.’ Otherwise, I_{SRC} and I_{SINK} are off. When bit D11 is set to ‘1,’ MOS diagnostic is enabled. Depending upon the state of bit D10, either a low side MOS or a high side MOS will be switched on. When bit D 11 is set to ‘0,’ MOS diagnostic is disabled and bit D10 ignored. When bit D9 is set to ‘1,’ a diagnostic current source is enabled. Bit D8 determine if I_{BIAS} or I_{SRC} will be switched on. When bit D9 is set to ‘0,’ the diagnostic current sources is disabled and bit D8 ignored. Bit D2 through bit D0 selects a specific channel, which will be connected. The decoding scheme of this channel selection is shown ahead.

Continuity tests and MOS diagnostics are performed through comparators which set proper bits on diagnostic register.

Differential amplifier used for squib resistance measure reflects the scaled voltage across SQH and SQL pins. AOUT is connected to the differential amplifier.

Externally, AOUT pin will be connected to an ADC input of a processor. When bit D7 is set to ‘1,’ AOUT output is enabled. Otherwise, AOUT is in a high impedance state. Multiple devices may be connected to a single ADC input of a processor. If an AOUT is driven, the rest of AOUT shall be driven to the high-impedance state.

The current sources (IBIAS and ISRC) and the AOUT/Comparators multiplexers are independently selectable. These multiplexers can address the same channel or individual channels. They cannot address multiple channels concurrently. It is not possible to source diagnostic current to more than one channel at a time. The AOUT multiplexer also selects the measurement channel for the short to ground SGth and short to battery SBth comparators. Please see [Figure 13](#) for the deployment driver diagnostic block diagram.

This flexibility in multiplexer addressing permits the detection of short between loops. To detect a short, enable the diagnostic current, direct it to channel X and monitor the MISO Diagnostic Mode Response bit D7 on the other channels. If no short exists between channel X and the channel under measurement, the MISO Diagnostic Mode Response will report a SQL voltage below SGth threshold (D7=1). If a short exists between channel X and the channel under measurement, the MOSI Diagnostic Mode Response will report a SQL voltage above SGth threshold (D7=0).

Diagnostic of multiple device, requires the ability to turn on a current source in one device, while reading AOUT voltage of another device.

Use the MOSI Diagnostic Mode Message to configure the device and the MISO Diagnostic Mode Response to measure the results. [Table 19](#) and [20](#) define the MOSI Diagnostic Mode Message and MISO Diagnostic Mode Response bits respectively.

Bit D6 through bit D4 selects a specific channel, which will be monitored. If AOUT output is enabled, AOUT shall reflect the voltage on the selected channel. Also, SB_{TH} and SG_{TH} status bits shall report the status of the respective channel. The decoding scheme of this channel selection is shown in the following table. The default states of these bits are '0' (channel 0 selected).

Table 20. Channel selection decoding

Bit D6	Bit D5	Bit D4	Channel Selected
Bit D2	Bit D1	Bit D0	
0	0	0	0
0	0	1	1
0	1	0	2
0	1	1	3
1	0	0	4
1	0	1	5
1	1	0	6
1	1	1	7

Bit D3 is used to calibrate AOUT. If this bit is set to '1,' AOUT pin contains the calibration voltage. The processor can use this calibration voltage to make adjustment to the subsequent resistance measurement reading. This is intended to improve the accuracy of the resistance measurement. When this bit is set to '0,' AOUT pin contains the resistance measurement results.

The default state of this bit is '0.'

4.11.5 Example of short between loops diagnostic

The following SPI frame sequence is an example how to detect a short between channel 0 and the other channels. The symbol % designates the bit to be tested. This bit is cleared to a 0 when there is a short between the selected channels. Bits D13 (Short to battery) and D3 (Over current on Squib) are relevant too. Both of them must be at 0 for no fault. It may happens that after leakage test on channel Y, channel Y is shorted to battery, so when X is biased and Y monitored for shorts between channels, D7=D3=0 while D13=1. This will highlight a short to battery.

1. Enable the diagnostic current; select IBIAS current; set the IBIAS/ISRC multiplexer to channel 0; set the AOUT/Comparators multiplexer to channel 1. The MISO read will depend on the previous MOSI message.

	D15	D14	D13	D12	D11	D10	D9	D8	D7	D6	D5	D4	D3	D2	D1	D0
MISO	1	0	1	1	0	0	1	0	0	0	0	1	0	0	0	0
MOSI	X	X	X	X	X	X	X	X	X	X	X	X	X	X	X	X

2. Set the AOUT/Comparators multiplexer to channel 2. The MISO read will be the results of the channel 0 to channel 1 test.

	D15	D14	D13	D12	D11	D10	D9	D8	D7	D6	D5	D4	D3	D2	D1	D0
MISO	1	0	1	1	0	0	1	0	0	0	1	0	0	0	0	0
MOSI	1	0	0	0	0	0	1	0	%	0	0	1	0	0	0	0

3. Set the AOUT/Comparators multiplexer to channel 3. The MISO read will be the results of the channel 0 to channel 2 test.

	D15	D14	D13	D12	D11	D10	D9	D8	D7	D6	D5	D4	D3	D2	D1	D0
MISO	1	0	0	1	0	0	1	0	0	0	1	1	0	0	0	0
MOSI	1	0	0	0	0	0	1	0	%	0	1	0	0	0	0	0

4. Set the AOUT/Comparators multiplexer to channel 4. The MISO read will be the results of the channel 0 to channel 3 test.

	D15	D14	D13	D12	D11	D10	D9	D8	D7	D6	D5	D4	D3	D2	D1	D0
MISO	1	0	1	1	0	0	1	0	0	1	0	0	0	0	0	0
MOSI	1	0	0	0	0	0	1	0	%	0	1	1	0	0	0	0

5. Set the AOUT/Comparators multiplexer to channel 5. The MISO read will be the results of the channel 0 to channel 4 test.

	D15	D14	D13	D12	D11	D10	D9	D8	D7	D6	D5	D4	D3	D2	D1	D0
MISO	1	0	0	1	0	0	1	0	0	1	0	1	0	0	0	0
MOSI	1	0	0	0	0	0	1	0	%	1	0	0	0	0	0	0

6. Set the AOUT/Comparators multiplexer to channel 6. The MISO read will be the results of the channel 0 to channel 5 test.

	D15	D14	D13	D12	D11	D10	D9	D8	D7	D6	D5	D4	D3	D2	D1	D0
MISO	1	0	0	1	0	0	1	0	0	1	1	0	0	0	0	0
MOSI	1	0	0	0	0	0	1	0	%	1	0	1	0	0	0	0

7. Set the AOUT/Comparators multiplexer to channel 7. The MISO read will be the results of the channel 0 to channel 6 test.

	D15	D14	D13	D12	D11	D10	D9	D8	D7	D6	D5	D4	D3	D2	D1	D0
MISO	1	0	1	1	0	0	1	0	0	1	1	1	0	0	0	0
MOSI	1	0	0	0	0	0	1	0	%	1	1	0	0	0	0	0

8. MOSI message will configure the device to test for a short between channel 1 and the remaining channels. Previously verified is the integrity of channel 0 to 1. Set the IBIAS/ISRC multiplexer to channel 2; set the AOUT/Comparators multiplexer to channel 3. The MISO read will be the results of the channel 0 to channel 7 test.

	D15	D14	D13	D12	D11	D10	D9	D8	D7	D6	D5	D4	D3	D2	D1	D0
MISO	1	0	1	1	0	0	1	0	0	0	1	0	0	0	0	1
MOSI	1	0	0	0	0	0	1	0	%	1	1	1	0	0	0	0

Clearing the MOSI Diagnostic Mode Message D7 places the AOUT pin in high impedance. This feature allows the connection of multiple AOUT pins to a single A/D input. Only one AOUT pin should be enabled at any given time.

4.11.6 Deployment driver monitor mode

Monitor Mode message is defined as shown in the following table.

Table 21. MOSI monitor mode message definition

Bit	State	Description
D15	1	Mode Bits
D14	1	
D13	-	Odd Parity
D12	-	Don't Care
D11	-	Don't Care
D10	-	Don't Care
D9	-	Don't Care
D8	0	Report Deploy Success Flag (default)
	1	Report Deployment OR Deploy Success Flag
D7	0	Keep Deploy Success Flag Channel 7 (default)
	1	Clear Deploy Success Flag Channel 7

Table 21. MOSI monitor mode message definition (continued)

Bit	State	Description
D6	0	Keep Deploy Success Flag Channel 6 (default)
	1	Clear Deploy Success Flag Channel 6
D5	0	Keep Deploy Success Flag Channel 5 (default)
	1	Clear Deploy Success Flag Channel 5
D4	0	Keep Deploy Success Flag Channel 4 (default)
	1	Clear Deploy Success Flag Channel 4
D3	0	Keep Deploy Success Flag Channel 3 (default)
	1	Clear Deploy Success Flag Channel 3
D2	0	Keep Deploy Success Flag Channel 2 (default)
	1	Clear Deploy Success Flag Channel 2
D1	0	Keep Deploy Success Flag Channel 1 (default)
	1	Clear Deploy Success Flag Channel 1
D0	0	Keep Deploy Success Flag Channel 0 (default)
	1	Clear Deploy Success Flag Channel 0

Odd parity check includes all 16 bits. “Don’t care” bit is included in the parity check as well.

Bit D8 is used to select the meaning of bit D7 through bit D0 in the status response message.

When this bit is set to ‘1,’ bit D7 through D0 in the status response message report the deployment status OR the deploy success flag. Once the deployment starts, bit D7 through bit D0 report ‘1’ until the deploy success flag is cleared. Bit D7 through bit D0 shall not report ‘0’ before the deploy success flag is cleared.

The default state of this bit is ‘0.’ When this bit is ‘0,’ bit D7 through bit D0 in the status response message report the deploy success flag. Deploy success flags are cleared by bit D7 through bit D0 in the monitor mode command. Deployment status bits report the deployment state. If the deployment is active during a rising edge of CS_D, deployment status bits is set to ‘1.’ Otherwise, is set to ‘0.’

If bit D8 in the monitor mode command changes state, bit D7 through bit D0 report the proper states of the internal signals/flags. Deploy command success bit indicates if the corresponding channel has finished its deployment sequence. This bit is set when deployment period, tDEPLOY, has expired.

Once this bit is set, it will inhibit the subsequent deployment command until a SPI command, to clear this deployment success flag, is received. Bit D7 through bit D0 is used to clear/keep the deploy success flag. When these bits are set to ‘1,’ the flag can be cleared. Otherwise, the state of these flags is not affected.

4.11.7 Deployment driver MISO bit definition

Table 22. MISO bit layout

MSB														LSB	
D15	D14	D13	D12	D11	D10	D9	D8	D7	D6	D5	D4	D3	D2	D1	D0

MISO mode bits are defined as below table.

Table 23. MISO mode bits definition

Bit D15	Bit D14	Description
0	0	Register mode response
0	1	Command mode response
1	0	Diagnostic mode response
1	1	Status response/SPI fault response

4.11.8 Deployment driver register mode response

Register Mode Response is the default response to the processor. After POR event, RESETB negated, and loss of GND, the device send \$0000 in MISO for the first SPI transmission. Register Mode Response is defined as shown in the following table.

Table 24. MISO register mode response definition

Bit	State	Description
D15	0	Mode Bits
D14	0	
D13	0	Don't Care
D12	-	Echo of MOSI Read/Write Bit
D11	0	Pulse Stretch Timer Duration
	1	Soft Reset Sequence
D10	0	Deployment Condition: $I_{\text{DEPLOY_12A}}$ and $t_{\text{DEPLOY_2ms}}$
	1	Deployment Condition: $I_{\text{DEPLOY_175A}}$ and $t_{\text{DEPLOY_1ms}}$
D9	-	Pulse Stretch timer (see Table 17)
D8	-	
D7	0	Don't Care
D6	0	Don't Care
D5	0	Don't Care
D4	0	Don't Care
D3	0	Don't Care
D2	0	Don't Care
D1	-	Hard Reset Status
D0	-	Soft Reset Sequence Status

Bit D12 used to reflect the status of MOSI Read/Write bit.

Bit D11 used to reflect the MOSI bit D11 in the previous command.

Bit D10 is used to indicate the deployment condition set in L9658. Refer to section 5.10.2 for deployment condition bit in MOSI register mode message.

Bit D9 and bit D8 used to report the period of the pulse stretch timer.

Bit D1 shall be used to indicate a "hard-reset" event. This bit shall be de-asserted ('0'), when POR is detected, RESETB is asserted, RIREF is out-of-range, or GND connection is lost. This bit shall be set to '1,' after the bit has been read. A soft reset sequence shall not affect this bit.

Bit D0 used to report the soft reset sequence status. If valid soft reset sequences are received, bit D0 is set to '1.' Otherwise, bit D0 is set to '0.'

When L9658 receives valid soft reset sequences, it will send MISO register mode response containing \$0001 in the next SPI transmission.

4.12 MISO register mode response summary

Table 24 below summarizes the MISO register mode response of various events and MOSI messages. The MISO response shown here is the one received in the next valid SPI transmission after each event or MOSI write.

Table 25. MISO register mode response summary

Event/MOSI message	MISO response
POR	\$0000
RESETB	\$0000
LOSS OF gnd	\$0000
R _{IREF} out of range	\$0000
MOSI Write Soft Reset: \$AA	\$1X02
MOSI Write Soft Reset: \$55 (after \$AA)	\$0003
MOSI Write Pulse Stretch Timer	\$1X02

4.12.1 Deployment driver command mode response

Command mode response is defined as shown here after.

Table 26. MISO command mode response definition

Bit	State	Description
D15	0	Mode Bits
D14	1	
D13	-	Don't Care
D12	0	DEPEN Negated
	1	DEPEN Asserted
D11	0	ARM67 Negated
	1	ARM67 Asserted
D10	0	ARM45 Negated
	1	ARM45 Asserted
D9	0	ARM23 Negated
	1	ARM23 Asserted
D8	0	ARM01 Negated
	1	ARM01 Asserted
D7	-	SPI Deploy Command Status: Channel 7
D6	-	SPI Deploy Command Status: Channel 6
D5	-	SPI Deploy Command Status: Channel 5
D4	-	SPI Deploy Command Status: Channel 4
D3	-	SPI Deploy Command Status: Channel 3
D2	-	SPI Deploy Command Status: Channel 2
D1	-	SPI Deploy Command Status: Channel 1
D0	-	SPI Deploy Command Status: Channel 0

DEPEN status flag (bit D12) indicates the state of DEPEN pin.

ARM status flag (bit D11 through bit D8) indicates the state of the respective arming signal, including the pulse stretch timer. If the pulse stretch timer is initiated by a deployment command, it shall not assert the arming status flag. This flag will be negated as soon as the de-glint timer is expired. ARM status flag is an OR-function of arming states from two channels.

SPI deploy command status flag indicates the SPI deployment status for the respective channel. These flags reflects bit D7 through bit D0 of the most recent SPI command mode message. These bits do not include the status of pulse stretch timer. These bits will be overwritten by the most recent SPI command mode message.

4.12.2 Deployment driver diagnostic mode response

Diagnostic Mode Response is defined as shown in table.

Table 27. MISO diagnostic mode response definition

Bit	State	Description
D15	1	Mode Bits
D14	0	
D13	0	SQH voltage below SB_{TH} threshold
	1	SQH voltage above SB_{TH} threshold
D12	0	DEPEN Negated
	1	DEPEN Asserted
D11	0	MOS Diagnostic Completed
	1	MOS Diagnostic In-progress
D10	0	LS MOS Diagnostic selected
	1	HS MOS Diagnostic selected
D9	0	Diagnostic Current OFF
	1	Diagnostic Current ON
D8	0	Diagnostic Bias Current, I_{BIAS} selected
	1	Resistance Measurement Current, I_{SRC} selected
D7	0	SQL voltage above SG_{TH} threshold
	1	SQL voltage below SG_{TH} threshold
D6	-	AOUT/Comparator Channel Selection
D5	-	
D4	-	
D3	0	Squib Current below V_{L_TH} threshold
	1	Squib Current above V_{L_TH} threshold
D2	-	Diagnostic Current: Channel Selection
D1	-	
D0	-	

SB_{TH} threshold status flag (bit D13) indicates the state of SB_{TH} comparator. SB_{TH} comparator monitors the voltage on SQH pin.

DEPEN status flag (bit D12) indicates the state of DEPEN pin.

MOS Diagnostic status flag (bit D11) report the status of a driver diagnostic. This bit is not latched. When a MOS diagnostic has already completed, this bit is cleared. Low side or High side MOS diagnostic status flag (D10) indicates if there is an on-going low or high side driver diagnostic. This bit shall be use in conjunction with bit D11.

Diagnostic current status flag (D9) indicates the state of diagnostic current. Bit D8 indicates which diagnostic current is selected. This bit shall be used along with bit D9 to indicate if a diagnostic bias current or resistance measurement current is on or off.

SG_{TH} threshold status flag (bit D7) indicates the state of SG_{TH} comparator. SG_{TH} comparator monitors the voltage on SQL pin.

AOUT/Comparator channel select bits (bit D6..4) indicate which channel is being monitored by AOUT or SB_{TH}, SG_{TH}, V_{I_TH} comparators.

V_{I_TH} threshold status flag (bit D3) indicates the state of V_{I_TH} comparator. V_{I_TH} comparator monitors the voltage across SQH and SQL pins.

Diagnostic current channel select bits (bit D2..0) indicate which channel is being applied by the diagnostic current.

4.12.3 Deployment driver status response

Status Response is defined as in following table.

Table 28. MISO status response definition

Bit	State	Description
D15	1	Mode Bits
D14	1	
D13	0	Always 0
D12	0	DEPEN Negated
	1	DEPEN Asserted
D11	0	ARM67 Negated
	1	ARM67 Asserted
D10	0	ARM45 Negated
	1	ARM45 Asserted
D9	0	ARM23 Negated
	1	ARM23 Asserted
D8	0	ARM01 Negated
	1	ARM01 Asserted
D7	0	No Deployment Event: Channel 7
	1	Deploy Status: Channel 7
D6	0	No Deployment Event: Channel 6
	1	Deploy Status: Channel 6
D5	0	No Deployment Event: Channel 5
	1	Deploy Status: Channel 5
D4	0	No Deployment Event: Channel 4
	1	Deploy Status: Channel 4
D3	0	No Deployment Event: Channel 3
	1	Deploy Status: Channel 3
D2	0	No Deployment Event: Channel 2
	1	Deploy Status: Channel 2
D1	0	No Deployment Event: Channel 1
	1	Deploy Status: Channel 1
D0	0	No Deployment Event: Channel 0
	1	Deploy Status: Channel 0

DEPEN status flag (bit D12) indicates the state of DEPEN pin.

ARM status flag indicates the state of the respective arming signal, including the pulse stretch timer. If the pulse stretch timer is initiated by a deployment command, it does not assert the arming status flag. This flag is de/asserted as soon as the de-glitch timer is expired.

Deploy status bits (bit D7 through bit D0) report the status of internal deployment. Bit D8 in the monitor mode command determines which status information device needs to be reported in D7 through bit D0.

4.12.4 Deployment driver SPI fault response

This SPI fault response indicates a fault in the last MOSI transmission. The device uses the parity bit to determine the integrity of the MOSI command transmission. This response is defined as shown in the following table.

Table 29. MISO SPI fault response

Bit	State	Description
D15	1	Always '1'
D14	1	Always '1'
D13	1	Always '1'
D12	0	Parity error or message error during a deployment ⁽¹⁾
	1	Incorrect number of clocks/bits
D11 – D0	0	Don't Care

1. When a parity error is detected, the L9658 reports E000h. During a deployment, when an invalid message is detected, the L9658 reports also E000h. Refer to [Table 12](#) for the description of an invalid message during a deployment. Bit D12 reports an incorrect number of clocks/bits. When an incorrect number of clocks/bits is detected, bit D12 is asserted (F000h).

4.13 Arming SPI bit definition

4.13.1 Arming MOSI_A bit definition

Arming MOSI_A is defined as shown in figure below.

Table 30. Arming MOSI_A bit definition

7	6	5	4	3	2	1	0
ARM67	ARM45	ARM23	ARM01	ARM67*	ARM45*	ARM23*	ARM01*

4.13.2 ARM[01..67]

Arming command. These bits are used to enable/disable arming signal. A value of 1 enables the arming signal for the respective loop-pair. A value of 0 disables the arming signal for the respective loop-pair. When device is in reset, all arming signals are disabled.

4.13.3 ARM[01..67]*

Arming-command complement. These bits are the complements of ARM[01..67] bits and will be used to confirm the transmission of arming signals. If L9658 does not receive valid complement bits, it will ignore the arming command.

4.13.4 Arming MISO_A bit definition

Arming MISO_A is defined in table below.

Table 31. Arming MISO_A bit definition

7	6	5	4	3	2	1	0
ARM67	ARM45	ARM23	ARM01	ARM67	ARM45	ARM23	ARM01

4.13.5 ARM[01..67]

Arming status. These bits are used to echo arming bits sent in the previous arming command. A value of 1 indicates that arming signal is enabled for the respective loop-pair. A value of 0 indicates that arming signal is disabled for the respective loop-pair.

The default state of these arming signals is '0' (disabled).

4.14 Satellite sensor interface

The device provide four currents limited to 60mA each through outputs ICH1, ICH2, ICH3 and ICH4. The voltage at these four channels is supplied by the V8BUCK input. Channels 1, 2, 3 and 4 serves as switched power sources to remote mounted satellite sensors, each will draw 2 current levels. The L9658 will monitor the current flow from its output pin and “demodulate” the current to be decoded using Manchester protocol. Decoded satellite message is communicated to an external microprocessor via SPI.

Figure 18. Satellite interface block diagram

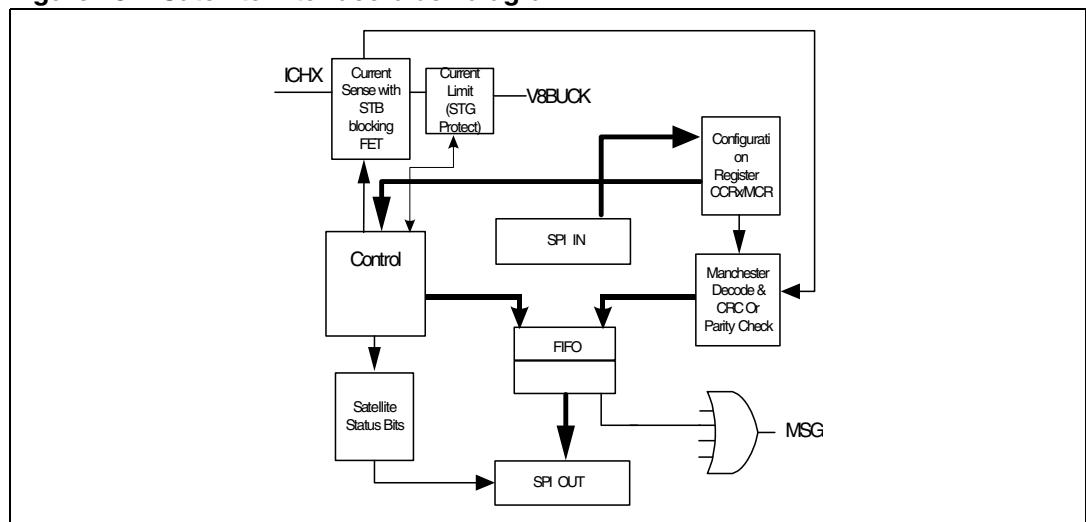

4.14.1 Current sensor

Each output channel senses the current drawn by the remote satellite sensor; the circuit modulates the load current into logic voltage levels for post processing by a manchester decoder. Each channel has an internal comparator with a programmable currents trip points selectable through the appropriate setting in the CCR Register for each of the 4 satellite channels. The current sense comparator provides a hysteresis, which can be enabled through appropriate setting in the CCR Register. Each comparator output have a de-glitch filter as a function of the protocol speed as defined in the AC characteristic table. Each current is limited to 150 mA maximum and includes a fault timer.

If the output for a given channel is in current limited for a period of time exceeding the output fault timer, the IC will report an over current fault via SPI and latch off the affected channel, the channel will remain in latch off mode until the user send a SPI command to re-activate the channel. When the output is shorted to battery, an internal comparator senses the output voltage level then turn off an internal series transistor to provide blocking diode for the current going through the output channel, the output will resume normal operation once the fault condition is removed. The comparator have 20 to 50 mV input offset to prevent turning off the output under an open circuit condition. In case of loss of VCC all output will remain off.

4.14.2 Manchester decoding

The L9658 decodes satellite messages based on Manchester decoding, each of the four satellite channels have a Manchester decoder that can be enabled or disabled through the CCR register. An example of Manchester decoding is given below; logic 0 is defined as a signal transition from 0 to 1 at 50 % Duty cycle, logic 1 is defined as a signal transition from 1 to 0 at 50 % duty cycle.

The IC starts decoding the satellite message after it receives two SYNC bits defined as logic 00, the SYNC bits are used to determine the bit rate of the incoming message and are used as the time base in decoding the following bits; different bit rates ranges are programmable via SPI, in case the measured bit rate obtained using the 2 SYNC bits doesn't fall within the range selected by he SPI as defined, the device declares a bit time error, revert to the minimum bit time of the selected range, and wait for idle.

Figure 19. Manchester decoding

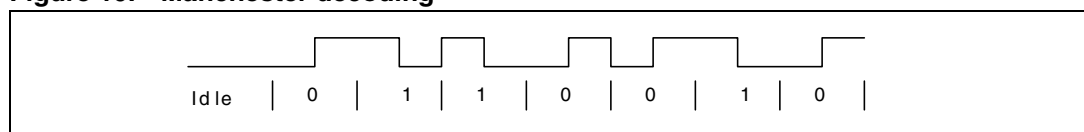
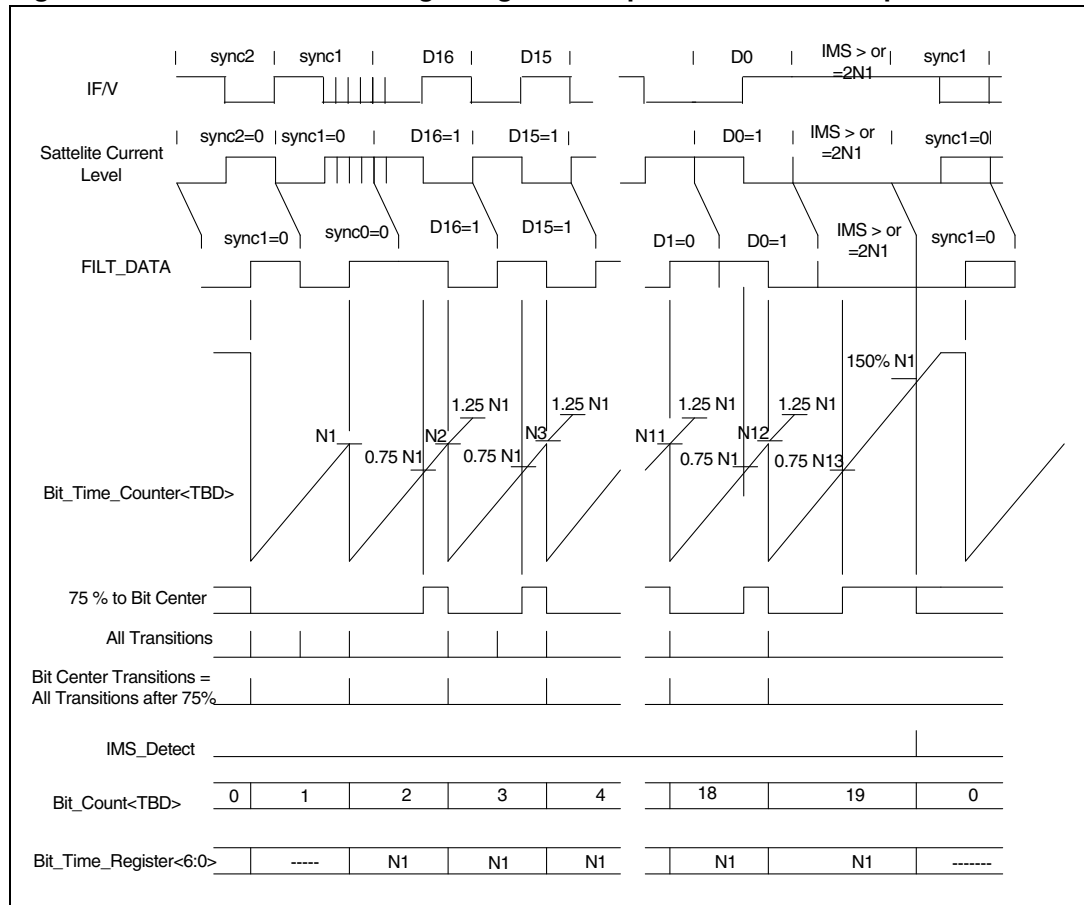

Figure 20. Manchester decoding using satellite protocol as an example



The decoder uses a counter to track the high to low and low to high transitions at the bit center. A transition is considered a bit center only when an edge is detected 75 % to 125 % of the reference bit time. When a single edge occurs below 75% of the reference bit time it is considered to be a bit edge but it is ignored. When the decoder detects a second edge below 75 % of the reference bit time the device declares a bit time error via SPI, revert to the minimum bit time of the selected range, and wait for idle. When a valid bit center is detected the counter will reset and start counting again until another edge is detected. If the message is not complete and no edge is detected in the range of 75 % to 125 % of measured bit time, the device declares a bit time error via SPI, revert to the minimum bit time of the selected range, and wait for idle. The idle time is defined as 150 % of the minimum bit time of the selected protocol speed range. If there is no bit transition detected for that period of time and the correct number of bits was received, the message is considered complete.

Bit time error and too many bits faults are stored directly into the FIFO once they are selected without the need to wait till an idle time. Since a bit time error is reported directly once it is detected before Idle time, too few bits error may never be reported since bit time error is detected first.

Bit time errors and too many bits errors will cause the decoder to revert to the minimum bit time of the selected range, and discard the message. In case of a message containing multiple errors only one error code is reported per message, errors detected in the decoding phase have the following reporting priority; bit time errors, too many bits errors then communication errors (CRC/Parity).

Upon power up or after a reset, the device requires at least 1.5 Idle bit-time based on 52.33khz protocol speed or 28.65us before starting to decode the first message, bit-time shall adapt to the period obtained based on the two sync bits there after.

4.14.3 Communication protocols

The L9658 supports two different communication protocols that are widely used by different automotive manufactures. One is based on the protocol used by "A" satellite sensors and the other is "B" protocol that supports variable length messages based on BOSH, PAS3 and PAS4 protocols. Bits D11D12 in the CCR Register are used to configure the device in order to use any of these protocols.

4.14.4 "A" protocol

The Delphi sensors satellites protocol supported by this device is shown below. The message consists of 5 bits CRC cyclic redundancy check error, 12 bit of data and two sync bits. This information could be sensor's trace-ability data, or crash severity or velocity data. The two most significant bits in the data field sent by the sensor can identify these data types.

Figure 21. "A" satellite protocol

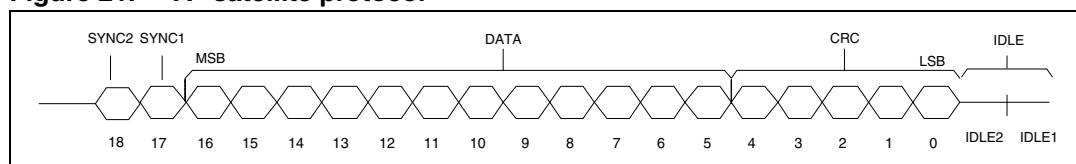

The CRC error detection code is based on the polynomial $x^5 + x^2 + 1$. The L9658 processes all incoming message through the CRC verification and report an error message via SPI in case of a CRC mismatch. CRC is performed after a complete message is received, and in case of CRC error, the device sets a fault code via SPI.

4.14.5 "B" variable length protocol

Figure 22. "B" satellite protocol

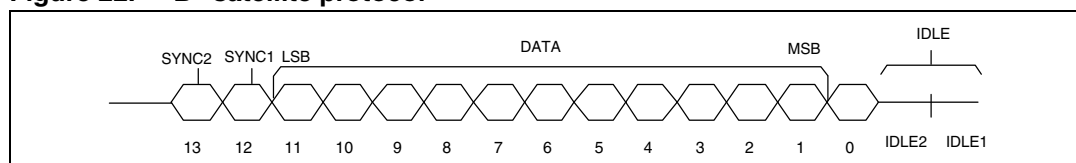

The L9658 IC shall supports "B" satellite protocol, which is based on Bosch sensors PAS3\PAS4 protocols (In [Figure 22](#) bit order is opposite to PAS3/PAS4 protocol in which LSB is sent first and MSB last) with added flexibility that the message length in the data field can be programmed to accept any number of bits between 8 and 11. The protocol consists of a parity bit, a data field (configurable between 8 to 11 bits) and two sync bits. The IC can be enabled to use this protocol through the appropriate setting in the MCR register. Once the protocol is enabled for a specific channel, the protocol speed is configured by setting the appropriate bits in the CCR register for that particular channel. A parity check is performed after a complete message is received, and in case of a parity error, the device sets a fault code via SPI.

4.14.6 FIFO buffer

The IC includes 4 internal FIFO buffers; one for each output channel, each one is 12 bits and two levels deep. When D1 in the MCR register is set to 0 (default condition), MSG pin is asserted and remain asserted as long as there is a message in any of the 4 internal FIFO buffers.

The FIFO provides error flag via SPI in case of buffer data loss. When writing to a full FIFO the old data is lost. For example if the FIFO content at the bottom of the stack is \$0AA, an incoming message of \$090 will occupy the upper level of the FIFO stack, at this stage the FIFO is full, but the Data lost flag is not set. When writing another message to the FIFO, for example \$066, the Data lost flag is set and the final FIFO content is \$066 (top of stack) and \$090(bottom of stack). When a FIFO read operation is performed via SPI, The FIFO content \$090 is carried over by MISO and Data lost flag is unset. The Data lost flag is also unset when the FIFO is flushed via SPI command.

4.14.7 Satellite continuity check

Each output has a short circuit protection by independent current limit. When a short circuit occurs the output becomes current limited, a fault timer latch the output off and a fault condition bit is reported via SPI.

That output returns to normal operation when it is re-enabled via SPI and the current limit condition was removed, this fault condition does not interfere with the operation of any of the other output channels

4.14.8 (IFx/Vx) hall effect support mode

Channels 3 and 4 of the L9658 can be used to provide an analog feedback current as a 1/100th ratio of the sense current in this mode internal FIFO and decoder are bypassed. This will allow the IF3/V3 and IF4/V4 pins to be connected to a resistor to ground and provide an analog voltage equivalent to the sense current to be read by an A/D port. These two pins have an internal clamp as protection.

This mode of operation is accessed by the setting of D4 and D5 in the MCR register. When D4 and D5 are set to 1, pins IF3/V3 and IF4/V4 is configured as analog current output with 1/100th ratio of the sense current. This feature is available for Channels 3 and 4.

4.14.9 (IFx/Vx) raw data out mode

When D4 and D5 in the MCR register are set to 0 the IF3/V3 and IF4/V4 pins are configured as discrete output pins that provide logic level output voltage of the sensed current based on the internal current threshold set by the user through the CCR Register, which when used in conjunction with satellite sensors connected to channels 3 and 4 it can provide raw data out of the satellite message bypassing the internal decoder.

The output voltage has a reversed polarity to the satellite current such that when the current drawn by the satellite is below the current detection threshold, the IFx/Vx signal level transitions into a high state, on the other hand if the current drawn by the satellite exceeded the current detection threshold, IFx/Vx signal transitions into a low state. Bits D6 and D7 in the MCR register is used to disable this output if it is not used.

4.14.10 Message waiting

The MSG pin is asserted when there is a message in any of the 4 internal FIFO buffers. This pin is TTL level and is configurable to be either active high or active low signal.

The Pin shall also be programmable via SPI to either remain active during CS_S once is set or inactive during CS. IF the pin is configured to remain active during CS_S and there is a message in any of the internal FIFO it remains active even if CS_S is de-asserted. However if there are no messages in any of the internal 4 FIFOs the pin will be forced to inactive state.

4.14.11 Satellite serial data input (MOSI)

The MOSI input takes data from the master microprocessor while CS_S is asserted. The MSB is the first bit of each word received on MOSI and the LSB is the last bit of each word received on MOSI. This pin has TTL level compatible input voltages allowing proper operation with microprocessors using a 3.3 to 5.0 volt supply. MOSI Bits layout is provided here below.

4.14.12 Satellite MOSI bits definition

Table 32. Satellite MOSI bits layout

15	14	13	12	11	10	9	8	7	6	5	4	3	2	1	0
P	S	DATA (12:0)													

There are total of 5 internal registers that are used to configure all of the satellite channels. These registers are addressed by setting MOSI bit 14 according to this table and by sending the SPI commands sequentially in the correct order such that CH1 command is the first significant word and CH4 command is the Last word.

Table 33. MOSI satellite interface registers map

Bit	State	Description
D15		SPI Odd Parity
D14	0	MCR Master Configuration Register (CH1 Only)
	1	CCR1 Channel Configuration Register for CH1
	1	CCR2 Channel Configuration Register for CH2
	1	CCR3 Channel Configuration Register for CH3
	1	CCR4 Channel Configuration Register for CH4

The SPI command sequence is such that the first word communicates with channel 1, the second SPI word communicates with channel 2, the third SPI word is in communication with channel 3 and the 4th word with channel 4.

4.14.13 Satellite module configuration register (CH1 only)

This register define global configuration to the satellite module, in able to be executed correctly it has to be written for CH1 as the first word after the rising edge of CS_S. When an MCR command is written to any other channel than CH1, the IC ignores this command and reply with SPI message \$E000.

Table 34. Master configuration register definition (CH1 Only)

Bit	State	Description	
D13	0	Not Used	-
D12	0	"B" protocol setup for even parity	(default)
	1	"B" protocol setup for odd parity	-
D11	0	CH4 "A" Protocol Mode	(default)
	1	CH4 "B" Protocol Mode	-
D10	0	CH3 "A" Protocol Mode	(default)
	1	CH3 "B" Protocol Mode	-
D9	0	CH2 "A" Protocol Mode	(default)
	1	CH2 "B" Protocol Mode	-
D8	0	CH1 "A" Protocol Mode	(default)
	1	CH1 "B" Protocol Mode	-
D7	0	Disable IF4/V4 pin	-
	1	Enable IF4/V4 pin	-
D6	0	Disable IF3/V3 pin	-
	1	Enable IF3/V3 pin	-
D5	0	IF4/V4 operating in Satellite sensor Mode	(default)
	1	IF4/V4 operating in Hall effect sensor Mode	-
D4	0	IF4/V3 operating in Satellite sensor Mode	(default)
	1	IF4/V3 operating in Hall effect sensor Mode	-
D3	0	Not USED	-
D2	0	Not USED	-
D1	0	MSG Output remains active when CS_S asserted (default)	-
	1	MSG Output inactive when CS_S asserted	-
D0	0	MSG Output Active High	(default)
	1	MSG Output Active Low	-

Bits[1:0]

These bits configure the polarity and the behavior of the MSG

Bits[7:4]

These bits are used to enable CH3 and CH4 to operate in Hall effect sensor mode, disabled by default

Bits[11:8]

These bits are used to configure the output channels for either sensor protocols. In the “B” protocol mode a parity bit is used to verify communication between the satellite sensors and the IC.

The L9658 calculates the parity of the incoming message based on either odd parity or even parity, which is determined by the setting of bit D12. In case of communication parity mismatch a communication parity error shall be reported via SPI.

If none of the channels is configured for the “B” protocol a write operation to this bit is ignored.

Bit [12]

This Bit controls the parity calculation for incoming sensor messages to either even or odd parity; the selected setting applies to all channels operating in “B” protocol mode.

The setting of this bit is ignored by the IC for the channels configured for “A” protocol. The MCR register has to be written at least once in order for the device to be configured correctly, however it can be superseded with a CCR command.

4.14.14 Channel configuration registers (CCR1, CCR2, CCR3, CCR4)

This register is used to configure individual channels for proper satellite communication as required by the application please refer to below table 33 for bits definition.

Table 35. Channel configuration register definition

Bit	State	Description
D13	0	Don't Flush FIFO (Default)
	1	Flush FIFO
D12	0	Write to bits <D9-D0>, D12 and D13 only. All other CCR D12 bits shall keep previous setting.
	1	Write to D4, D5, D10, D11, D12 and D13 only. All other CCR bits shall keep previous setting.
D11	-	Mode Select (refer to Table 40)
D10	-	
D9	-	Bit Time Selection (refer to Table 39)
D8	-	
D7	0	"B" Protocols configuration bits (refer to Table 38) Only applies when CHx is configured to use "B" Only applies when CHx is configured to use "B" protocol through MCR otherwise treated as DON'TCARE
D6	1	
D5	-	Satellite/Decoder Control (refer to Table 37)
D4	-	
D3	0	Current Trip Point Hysteresis Disabled (default)
	1	Current Trip Point Hysteresis Enabled

Table 35. Channel configuration register definition

Bit	State	Description
D2	-	Current Trip Point threshold (refer to Table 36)
D1	-	
D0	-	

Bits[2:0]

These bits program the threshold for the current demodulation affecting each individual channel. The current ranges supported are given in [Table 36](#).

Table 36. Current ranges supported are given in following table

Bit D2	Bit D1	Bit D0	Current Threshold (mA)
0	0	0	16.50(default)
0	0	1	19.00
0	1	0	22.50
0	1	1	26.50
1	0	0	32.00
1	0	1	39.00
1	1	0	48.50
1	1	1	60.00

All incoming satellite signals are processed through deglitch filter before reaching the decoder. D3 enables a hysteresis around the current threshold for added noise immunity.

Bits[5:4]

These bits are used to enable the satellite channels and the internal decoders to be commanded on or off according to following table. Suggested sequence to avoid spurious error code inside FIFO is to switch on the channel first, and enable decoder only once satellite is powered.

Table 37. Satellite/decoder control

Bit D5	Bit D4	Definition	
		Satellite	Decoder
0	0	OFF (default)	OFF (default)
0	1	ON	OFF
1	0	ON	ON
1	1	OFF	OFF

Bits[7:6]

These bits are used to configure the number of bits in the "B" protocol data field. For these bits to execute on any given channel, the channel has to be configured for "B" protocol through bits <11:8> in the MCR register.

Table 38. "B" protocol configuration

Bit D7	Bit D6	Protocol Data Field
0	0	8bits(default)
0	1	9bits
1	0	10bits
1	1	11bits

Bits[9:8]

These bits shall configure speed selection for any of the satellite channels and they apply to both "A" and the "B" Manchester protocol. Upon power up or reset the protocol configuration shall initialize to the default speed as in shown in below table.

Table 39. Bit time selection

Bit D9	Bit D8	Guaranteed Frequency operating range (Hz)
0	0	13.3k to 52.33k (default)
0	1	26.32k to 110.74k
1	0	43.50k to 164.20k
1	1	62.66k to 250k

Bits[11:10]

These bits will be used to determine the requested information from each of the satellite channels internal registers. At power up or incase of POR condition these bits are initialized to 00 by the IC and MISO bits <12:0> shall default to the content of the MCR register.

Table 40. Mode select

Bit D11	Bit D10	Definition
00/01/10		Report This on Next MISO Bit 13 = SPI odd parity Bits<15:14>≥11 (Configuration Reports Mode)
0	0	If the previous command is a write to the MCR Register (default) Report <12:0> Table 35 (MCR) only for CH1
		If previous command is a write to the CCRx Register Report <12:0> Table 36 (CCR)
0	1	Report <12:0> Table 35 (MCR) (CH1 Only)
1	0	Report <12:0> Table 36 (CCR)
11		Report This on Next MISO Bit 13 = SPI odd parity Bits<15:14>≥ (Satellite Status 00,01 or 10)
1	1	Report FIFO data

In the auto reply mode where D11 D10 are set to 00, the IC will test every incoming MOSI command. If the command is a write command to a CCRx register then during the following CS_S the device reports back the content of the respective CCRx channel register. If the incoming command is a write to the MCR register for CH1 then in the following CS_S the device reports back the content of the MCR register.

If the MOSI command is a write to the CCRx register with bits <11:10> are set to 11 the IC reports the content of the FIFO. MISO bits layout when reporting FIFO data is provided, The MISO layout when reporting configuration report is provided in previous figure.

When reporting a configuration report for either the MCR or the CCR register MOSI bits <15:14> are set to 11 to indicate a configuration report. Otherwise they will report the status of the satellite channel.

In some cases the user may request a configuration report for either the MCR or CCRx registers without first performing the write operation mentioned above. In this condition if bits <11:10> are set to 01 by the user, device reports the content of the MCR register on the subsequent chip select. If bits <11:10> are set to 10 the IC reports the content of the CCR register.

In case of an SPI command to CH2, CH3 or CH4 with bits D11D10 are set to 00 while D14 is set to 0, or if D11D10 are set to 01 with D14 is set to either 0 or 1, the affected channel reports \$E000.

Table 41. SPI mode selects reply for satellite channels

D11	D10	CH1	CH2	CH3	CH4
0	0	Reply with CCR1 if D14 is 1	Reply with CCR2 if D14 is 1	Reply with CCR3 if D14 is 1	Reply with CCR4 if D14 is 1
		Reply with MCR if D14 is 0	Reply with \$E000 if D14 is 0	Reply with \$E000 if D14 is 0	Reply with \$E000 if D14 is 0
0	1	Reply with MCR	Reply with \$E000	Reply with \$E000	Reply with \$E000
1	0	Reply with CCR1	Reply with CCR2	Reply with CCR3	Reply with CCR4
1	1	Report FIFO	Report FIFO	Report FIFO	Report FIFO

Bit[12]

This Bit is used to Control the write operation for the CCR Register. When it is set to 0 the user can modify bits <D9-D0>, D12 and D13 only, all other CCR bits keep previous setting. When it is set to 1 the user can only modify the following bits D4, D5, D10, D11, D12 and D13, all other CCR bits keep previous setting

Bit[13]

This Bit is used to Flush FIFO content, when set to 1 the IC flushes the available two FIFO locations for the specified channel, all FIFO connect is lost in this case.

Table 42. Satellite MISO bits definition

15	14	13	12	11	10	9	8	7	6	5	4	3	2	1	0
M1	M0	P	DL	FIFO Data											

Table 43. SPI MISO bits layout when reporting FIFO data

15	14	13	12	11	10	9	8	7	6	5	4	3	2	1	0
M1	M0	P	Configuration Report												

4.14.15 SPI MISO Bits layout for configuration report

Status bits <15:14> indicate the status of L9658 output channels, status bits are updated at the falling edge of CS_S and defined by bits <15:14>. Fault codes are pushed into the and then removed form FIFO on rising edge of CS_S and reported through MISO.

Global and channels faults are encoded in the hexadecimal range between \$001 to \$01F. “Global faults” covers all satellite channels. “Channel Fault” covers only a particular channel.

Channel Fault codes are pushed into the FIFO once each time they occur while global faults are pushed into the FIFO once even if the fault is still present. Bit 13 is set by the IC to satisfy an odd parity for each of the transmitted word, therefore it will be set to 1 if the total number of 1’s for bits is even and to 0 if the total number of 1’s for bits is odd.

Table 44. MISO Manchester message data definition

Bit	State	Description
D15	-	Status Bits (refer to Table 45)
D14	-	
D13	-	Odd Parity
D12	0	No FIFO Data has been lost
	1	FIFO Data has been lost
D11:0		FIFO Contents

Table 45. Status bits definition

Bit D15	Bit D14	Definition
0	0	Current Channel is Off
0	1	Channel ON, Message processing Disabled
1	0	Channel ON, Message processing Enabled
1	1	Configuration report

Table 46. Satellites fault codes definition supporting “A” protocol

Bit D11:0 value	Fault definition	Function
\$0	No Faults (FIFO empty value)	Global Fault Codes Definition (Reported back for CH1 only & latched only once)
\$1	Unassigned	
\$2	Bad MOSI Bit Count	
\$3 - \$F	Unassigned	

Table 46. Satellites fault codes definition supporting "A" protocol

Bit D11:0 value	Fault definition	Function
\$10	High side current limit exceeded	Channel fault codes
\$11	Unassigned	
\$12	SPI Odd Parity Communication error	
\$13 - \$17	Unassigned	
\$18	Reserved message received	
\$19	Manchester Bit Time Error OR Too Few Bits	
\$1A	Too many bits (No Idle Condition after 19 th bit)	
\$1B	Reserved	
\$1C	CRC error	
\$1D - \$1F	Unassigned	
\$020 - \$FFF	Manchester sensor's data range	

Buffer data values from \$0 to \$1F are reserved and not transmitted by the "A" Manchester data sensor. All "A" satellite sensors use values between \$020 and \$FFF, therefore values falls within this range will be interpreted by system software as satellite only data. If a satellite data is found to be in the range between \$00 to \$01F the IC asserts the reserved message error flag or fault code. In case there is no fault condition present, the device returns \$000.

Data is lost when a data word is written to a full buffer. To alarm the user for this condition the DL (buffer data lost) flag shall be set.

Table 47. Satellites fault codes definition supporting “B” protocol

Bit D11:0 value	Fault Definition	Function
\$0	No Faults (FIFO empty value)	Global fault codes definition (Reported back for CH1 only & latched only once)
\$1	Unassigned	
\$2	Bad MOSI Bit Count	
\$3 - \$F	Unassigned	
\$10	High Side Current Limit Exceeded	Channel fault codes
\$11	Unassigned	
\$12	SPI Odd Parity Communication error	
\$13 - \$17	Unassigned	
\$18	Unassigned	
\$19	Manchester Bit Time Error OR Too Few Bits	
\$1A	Too Many Bits	
\$1B	Reserved	
\$1C	Satellite Communication Parity error	Manchester data
\$800 - \$FFF	Manchester sensor’s data range D11 shall be set to 1 by the IC when receiving sensor data. When reporting faults D11 shall be set internally by the IC to 0	

As mentioned earlier the L9658 supports a "B" Manchester data protocol, the data field for this protocol can be configured to any number of bits between 8 to 11 bits. Incoming data from the sensor using a "B" protocol shall be right justified by the IC. For example if the incoming message has only 8bits in the data filed. The device will transmit this message on MISO such that it occupies bits <7:0> bits 8,9 and 10 are set to 000.

Unlike DELPHI protocol, LSB will be the first bit on MISO.

Too Many Bits and Too Few Bits faults can be calculated based on the number of bits in the data field. So if we consider the 8 bit "B" protocol example discussed above a message with 9 bits in the data field should set the too many bits fault flag, on the other hand a message with 7 bits in the data field should set the too few bits fault flag.

When the L9658 is configured to use a the Manchester "B" protocol, the device set SPI MOSI D11 to 0 when reporting fault data and to 1 when reporting satellite data. This operation should allow both sensors "A" based or Generic based to use the same fault codes.

Table 48. Hall effect fault codes definition (CH3 and CH4) only

Bit D11:0 value	Fault definition	Function
\$0	No Faults (FIFO empty value)	No Faults
\$1 - \$F	Unassigned	Fault Codes
\$010	High Side Current Limit Exceeded	
\$12	SPI Odd Parity Communication error	

When either CH3 or CH4 is configured to interface with hall-effect sensor, MISO data reported VIA SPI for that specific channel will be as outlined in proper table. Global faults are not reported for channels configured in Hall effect sensor mode since they are only reported for CH1 while Hall effect sensor configuration is only possible for CH3 and CH4.

Upon power on or after a reset or POR conditions the MISO data will be initialized as follows; CH1 returns MCR configuration in report mode with parity bit is set accordingly. CH2, CH3, and CH4 return \$E000

5 Package information

In order to meet environmental requirements, ST offers these devices in different grades of ECOPACK® packages, depending on their level of environmental compliance. ECOPACK® specifications, grade definitions and product status are available at: www.st.com.

ECOPACK® is an ST trademark.

Figure 23. LQFP64 mechanical data and package dimensions

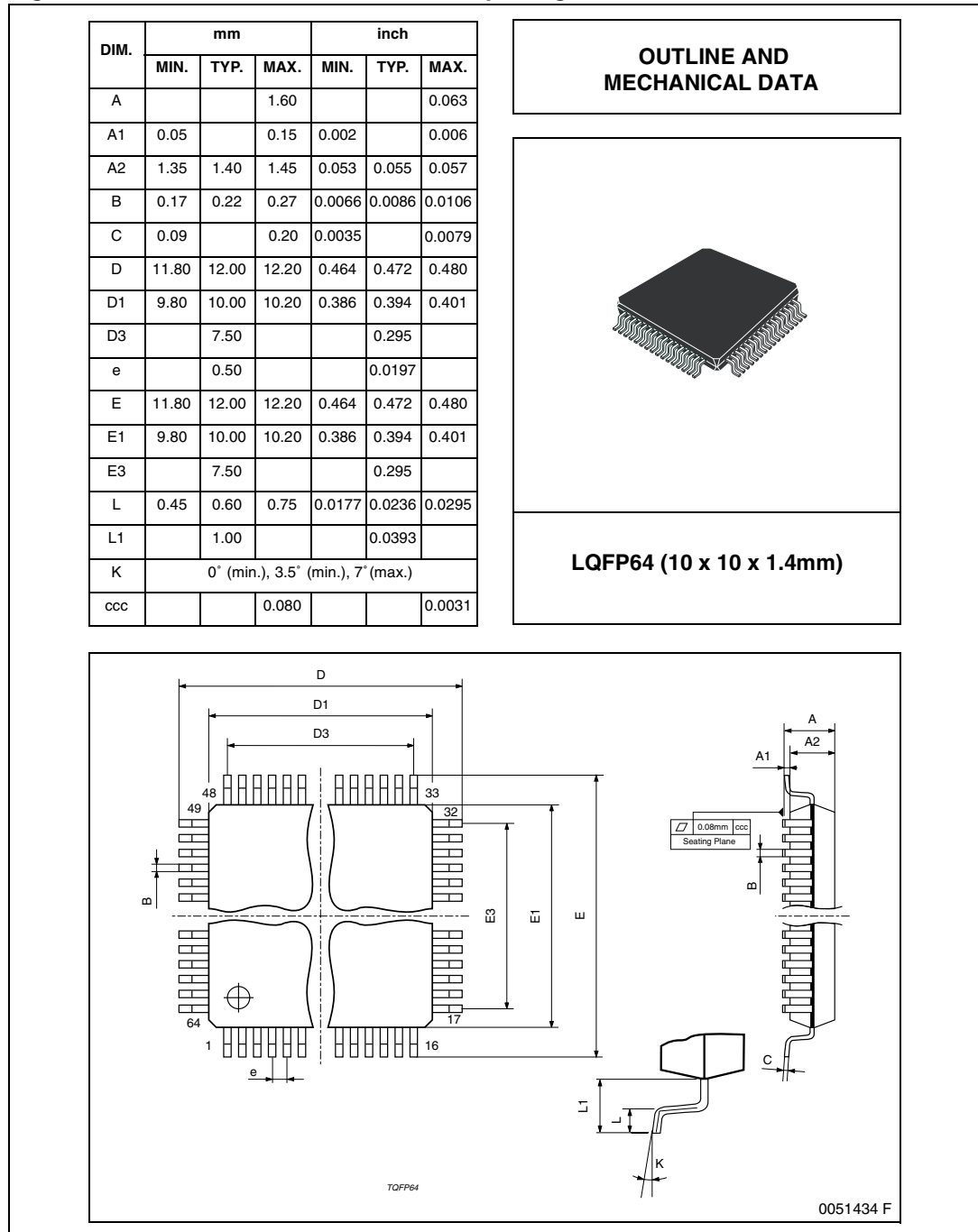

6 Revision history

Table 49. Document revision history

Date	Revision	Changes
28-Nov-2007	1	Initial release.
10-Dec-2010	2	Document status promoted from preliminary data to datasheet. Add Section 4.11.5: Example of short between loops diagnostic on page 38.
20-Sep-2013	3	Updated disclaimer

Please Read Carefully:

Information in this document is provided solely in connection with ST products. STMicroelectronics NV and its subsidiaries ("ST") reserve the right to make changes, corrections, modifications or improvements, to this document, and the products and services described herein at any time, without notice.

All ST products are sold pursuant to ST's terms and conditions of sale.

Purchasers are solely responsible for the choice, selection and use of the ST products and services described herein, and ST assumes no liability whatsoever relating to the choice, selection or use of the ST products and services described herein.

No license, express or implied, by estoppel or otherwise, to any intellectual property rights is granted under this document. If any part of this document refers to any third party products or services it shall not be deemed a license grant by ST for the use of such third party products or services, or any intellectual property contained therein or considered as a warranty covering the use in any manner whatsoever of such third party products or services or any intellectual property contained therein.

UNLESS OTHERWISE SET FORTH IN ST'S TERMS AND CONDITIONS OF SALE ST DISCLAIMS ANY EXPRESS OR IMPLIED WARRANTY WITH RESPECT TO THE USE AND/OR SALE OF ST PRODUCTS INCLUDING WITHOUT LIMITATION IMPLIED WARRANTIES OF MERCHANTABILITY, FITNESS FOR A PARTICULAR PURPOSE (AND THEIR EQUIVALENTS UNDER THE LAWS OF ANY JURISDICTION), OR INFRINGEMENT OF ANY PATENT, COPYRIGHT OR OTHER INTELLECTUAL PROPERTY RIGHT.

ST PRODUCTS ARE NOT DESIGNED OR AUTHORIZED FOR USE IN: (A) SAFETY CRITICAL APPLICATIONS SUCH AS LIFE SUPPORTING, ACTIVE IMPLANTED DEVICES OR SYSTEMS WITH PRODUCT FUNCTIONAL SAFETY REQUIREMENTS; (B) AERONAUTIC APPLICATIONS; (C) AUTOMOTIVE APPLICATIONS OR ENVIRONMENTS, AND/OR (D) AEROSPACE APPLICATIONS OR ENVIRONMENTS. WHERE ST PRODUCTS ARE NOT DESIGNED FOR SUCH USE, THE PURCHASER SHALL USE PRODUCTS AT PURCHASER'S SOLE RISK, EVEN IF ST HAS BEEN INFORMED IN WRITING OF SUCH USAGE, UNLESS A PRODUCT IS EXPRESSLY DESIGNATED BY ST AS BEING INTENDED FOR "AUTOMOTIVE, AUTOMOTIVE SAFETY OR MEDICAL" INDUSTRY DOMAINS ACCORDING TO ST PRODUCT DESIGN SPECIFICATIONS. PRODUCTS FORMALLY ESCC, QML OR JAN QUALIFIED ARE DEEMED SUITABLE FOR USE IN AEROSPACE BY THE CORRESPONDING GOVERNMENTAL AGENCY.

Resale of ST products with provisions different from the statements and/or technical features set forth in this document shall immediately void any warranty granted by ST for the ST product or service described herein and shall not create or extend in any manner whatsoever, any liability of ST.

ST and the ST logo are trademarks or registered trademarks of ST in various countries.

Information in this document supersedes and replaces all information previously supplied.

The ST logo is a registered trademark of STMicroelectronics. All other names are the property of their respective owners.

© 2013 STMicroelectronics - All rights reserved

STMicroelectronics group of companies

Australia - Belgium - Brazil - Canada - China - Czech Republic - Finland - France - Germany - Hong Kong - India - Israel - Italy - Japan - Malaysia - Malta - Morocco - Philippines - Singapore - Spain - Sweden - Switzerland - United Kingdom - United States of America

www.st.com