

QUAD LOW SIDE DRIVER

- WIDE INPUT VOLTAGE RANGE -24V UP TO +45V
- WIDE OPERATING SUPPLY VOLTAGE RANGE FROM 4.5V UP TO 32V
- REVERSE BIASING PROTECTED ($V_S = -24V$)
- VERY LOW STANDBY QUIESCENT CURRENT $< 2\mu A$
- PROGRAMMABLE SIGNAL TRANSFER POLARITY
- TTL AND CMOS COMPATIBLE INPUTS
- DEFINED OUTPUT OFF STATE OFF FOR OPEN INPUTS
- FOUR OPEN DRAIN DMOS OUTPUTS, WITH $R_{Dson} = 1.5 \Omega$ at $25^\circ C$ and $V_S > 6V$
- OUTPUT CURRENT LIMITATION
- CONTROLLED OUTPUT SLOPE FOR LOW EMI
- OVERTEMPERATURE SHUT-DOWN
- INTEGRATED OUTPUT CLAMPING FOR FAST INDUCTIVE RECIRCULATION $V_{FB} > 45V$
- STATUS MONITORING FOR
 - OVERTEMPERATURE

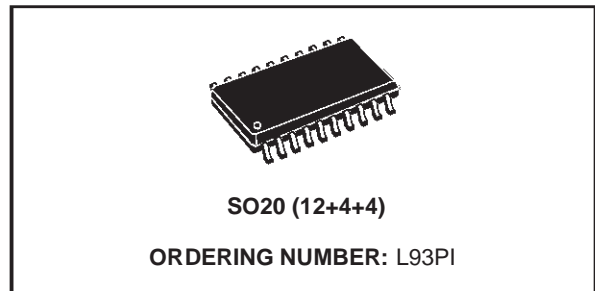

- DISCONNECTED GROUND OR SUPPLY VOLTAGE
- ESD: ALL PINS ARE GUARANTEED TILL 2kV HUMAN BODY MODEL

DESCRIPTION

The L93PI is a monolithic integrated quad low side driver realized in advanced Multipower-BCD technology. It is intended to drive lines, lamps or relays in automotive or industrial applications.

BLOCK DIAGRAM

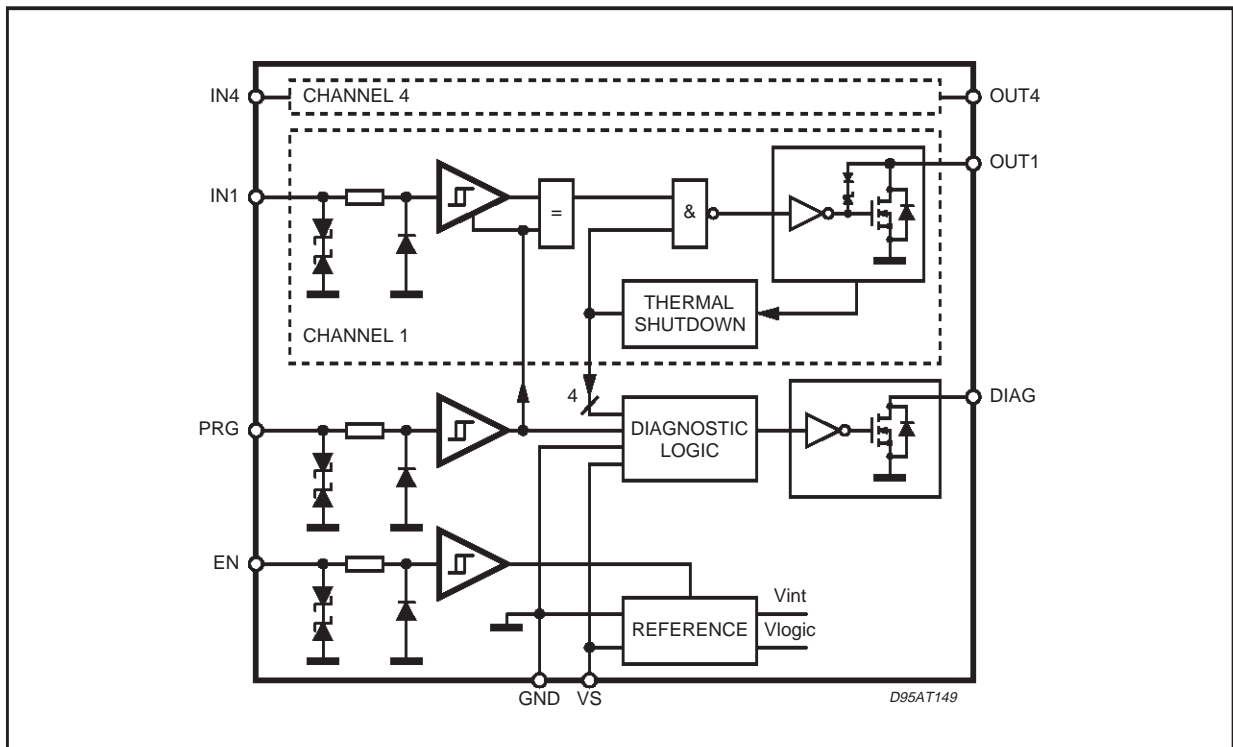

L93PI

ABSOLUTE MAXIMUM RATINGS (no damage or latch)

Symbol	Parameter	Value	Unit
V_S	Supply voltage	-24 to 45	V
Pin voltages			
V_{IN}	Input, enable, program	-24 to 45	V
V_{OUT}	Output	-0.3 to 45	V
V_{DIAG}	Diagnostic output	-0.3 to 45	V
E_X	Max. Energy During Flyback	2	mJ

PIN CONNECTION (Top view)

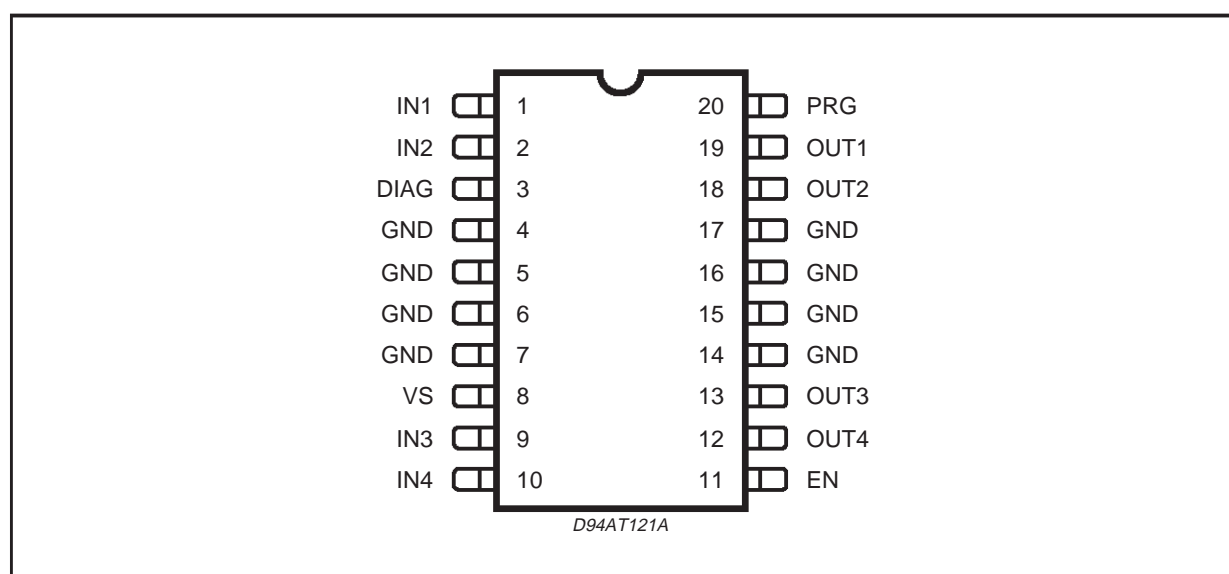

PIN DESCRIPTION

No	Pin Name	Function
8	VS	SUPPLY VOLTAGE
4,5,6,7,14, 15,16,17	GND	GROUND
11	EN	ENABLE
20	PRG	PROGRAM
3	DIAG	DIAGNOSTIC
1	IN1	INPUT 1
2	IN2	INPUT 2
9	IN3	INPUT 3
10	IN4	INPUT 4
19	OUT 1	OUTPUT 1
18	OUT 2	OUTPUT 2
13	OUT 3	OUTPUT 3
12	OUT 4	OUTPUT 4
–	NC	NOT CONNECTED

THERMAL DATA

Symbol	Parameter	SO20 (2)	SO(12+4+4) (1)	Unit
$R_{th(j-pins)}$	Thermal resistance junction to pin	–	14 (Typ.)	°C/W
$R_{th(j-amb)}$	Thermal resistance junction to ambient mounted on SMPCB2 board	77 to 97	–	°C/W
T_{jMon}	Temperature-monitoring Switch-off-level Switch-on-level		160 to 190 140 to 170	°C °C

(1) See SGS-THOMSON Microelectronics databook: "Thermal Management in Surface Mount Technology"

(2) See SGS-THOMSON Microelectronics databook: "Thermal characteristics of SO20"

OPERATING CONDITIONS (The electrical characteristics are valid within the below defined operating ranges, unless otherwise specified. The function will be guaranteed by design until T_{jMON} switch-OFF-level.

Symbol	Parameter	Value	Unit
V_S	Supply Voltage	4.5 to 40	V
V_{IN}	Input pin voltage	-24 to 10	V
V_{EN}	Enable pin voltage	-24 to 45	V
V_{OUT}, V_D	Output pin voltage	-0.3 to 45	V
T_j	Junction temperature	-40 to 150	°C

ELECTRICAL CHARACTERISTICS (Refer to the test circuit, unless otherwise specified.)

Symbol	Parameter	Test Condition	Min.	Typ.	Max.	Unit
I_Q	Quiescent current	$-0.3V \leq V_{EN} \leq 0.5V$; $V_S = 14V$; $T_j = 85^\circ C$		<2	10	μA
		EN = high; $V_S \leq 14V$		1.5	2	mA
Inputs IN1 - IN4, PRG						
V_{INlow}	Input voltage LOW		-24		2.0	V
V_{INhigh}	Input voltage HIGH		2.8		45	V
I_{IN}	Input current	$-24V \leq V_i \leq 10V$	-10		15	μA
Enable Input EN						
V_{ENlow}	Input voltage LOW		-24		1	V
V_{ENhigh}	Input voltage HIGH		3.2		VS	V
R_{EN}	Input impedance	$-24V < V_i < 2.5V$	10			K Ω
I_{EN}	Input current	$2.5V \leq V_i \leq 25V$		20	50	μA
Outputs OUT1-OUT4						
R_{DSon}	Output ON-resistor to ground	$V_S \geq 6V$, $I_O = 0.3A$ $T_j = 25^\circ C$ $T_j = 125^\circ C$		1.7	2.3 3.5	Ω Ω
I_{OLeak}	Leakage current	$V_O = V_S = 14V$; $T_j = 85^\circ C$		≤ 1	5	μA
V_{OClamp}	Output voltage during clamping	time < 200 μs ; $10mA \leq I_O \leq 0.3A$	45	52	60	V
I_{OSC}	Short-circuit current		400	700	1200	mA
C_O	Internal output capacities	$V_O \geq 4.5V$			100	pF
Diagnostic output DIAG						
V_{Dlow}	Output voltage LOW	$I_{DL} \leq 1mA$		0.3	0.5	V
I_{Dmax}	Max. Output current	Internal current limitation	1	5	15	mA
I_{Dleak}	Leakage current	$V_S = 14V$; $T_j = 85^\circ C$		≤ 0.1	1	μA

ELECTRICAL CHARACTERISTICS (Continued)

Symbol	Parameter	Test conditions	Min.	Typ.	Max.	Unit
Timing (see Fig. 1)						
$t_{d,on}$	On delay time	$V_S = 14V, C_{ext} = 0pF$ $10mA \leq I_o \leq 200mA$		2.5	3.5	μs
$t_{d,off}$	Off delay time			3	4.5	μs
t_{set}	Enable settling time				10	μs
$t_{d,DIAG}$	On or Off diagnostic delay time				10	μs
S_{out}	Output slopes		2.5	9	16	$V/\mu s$

Figure 1

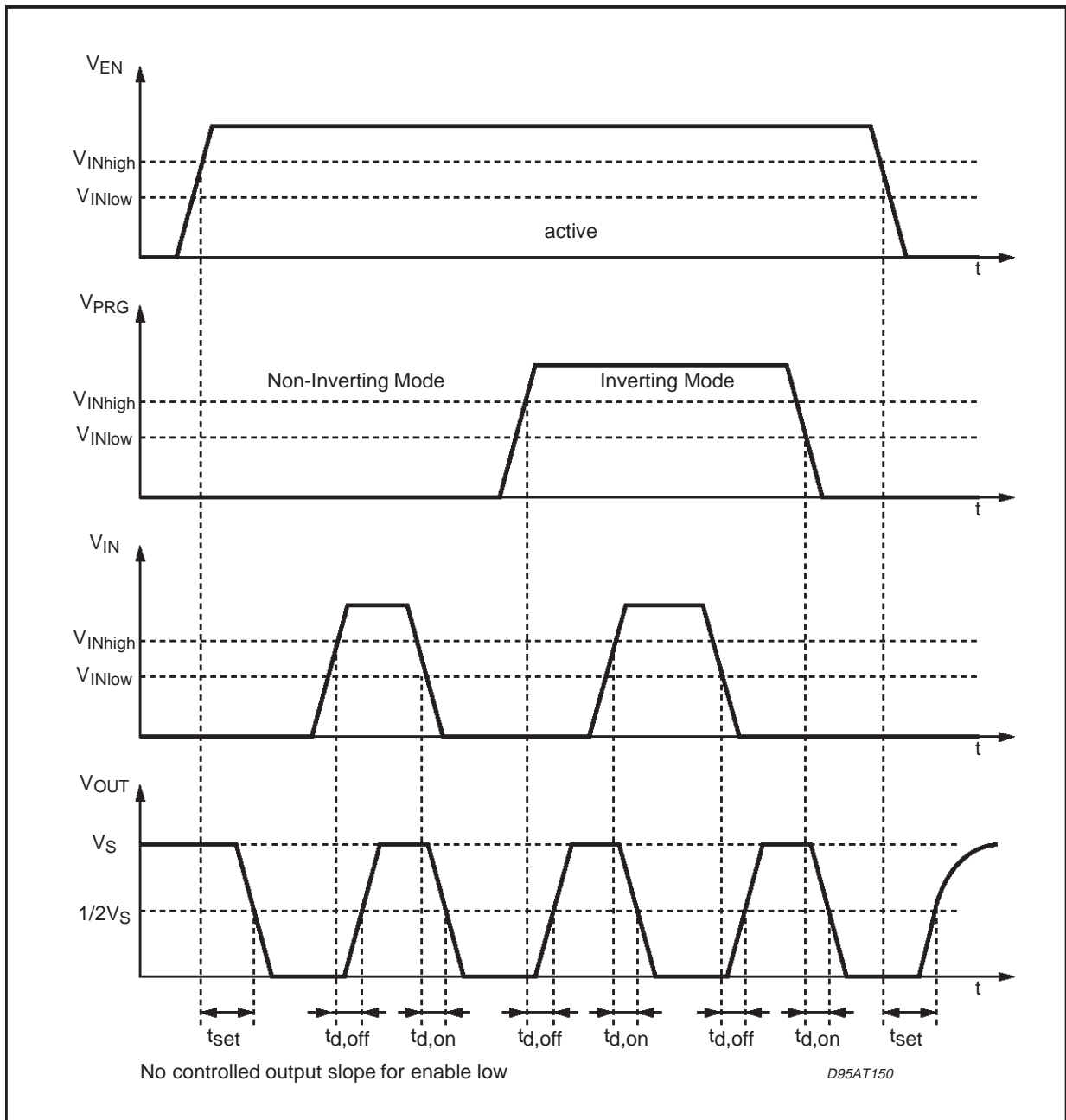

CIRCUIT DESCRIPTION

The L93PI is a quad low side driver for lines, lamps or inductive loads in automotive and industrial applications.

All Inputs are TTL or CMOS compatible. This allows the device to be driven directly by a microcontroller. For the noise immunity, all inputs have a Schmitt-trigger with a hysteresis of typ. 100mV. Each input stage has an input voltage protection from -24V to 45V. The device can be activated with a 'high' signal on ENable input. ENable 'low' switches the device into the sleep mode. In this mode the quiescent current is less than 10 μ A. A high signal on PRoGramming input changes the signal transfer polarity from noninverting into the inverting mode. Normally this pin is connected to V_s or GND. These pins (PRG and EN) are internally fixed at low status by open input condition. Independent of the PRoGramming input, the OUTput switches off, if the signal INput pin is not connected.

Each output driver has a current limitation of min 0.4A and a separate thermal shut-down. The thermal shut-down deactivates that output which ex-

ceeds Temperature switch off level. About 20K below this temperature threshold the output will be activated again. This means, that each output is able to sink continuously 285mA without activating thermal shut-down at 85°C ambient temperature (SO20). The slew rate of the output is limited to max. 14V/ μ s to reduce the electromagnetic interference, but not for the enable transfer characteristic (see fig. 1). An integrated active flyback voltage limitation clamps the output voltage during the flyback phase of inductive loads to typ. 50V. The power DMOS switches ON, if the device is enabled and the OUTput swings below ground. This protection avoids the activation of parasitics inside the power DMOS.

The DIAGnostic is an open drain output. The logic status depends on the PRoGramming pin. If the PRG pin is 'low' the DIAG output becomes low, if the device works correctly.

At thermal shut-down of one channel, disconnected ground or supply voltage the DIAGnostic output becomes high. If the PRG pin is 'high' this output is switched off at normal function and switched on at overtemperature.

DIAGNOSTIC TABLE

Pins	EN	PRG	IN	OUT	DIAG
Normal function	H	L	L	L (on)	L (on)
	H	L	H	H (off)	L (on)
	H	H	L	H (off)	H(off)
	H	H	H	L (on)	H(off)
	L	X	X	H (off)	H(off)
Overtemperature, disconnected ground or supply voltage	H	L	X	H (off) *	H (off)
Overtemperature	H	H	X	H (off) *	L (on)

X = not relevant * selective for each channel at overtemperature

Figure 2: Application circuit for inverting transfer polarity.

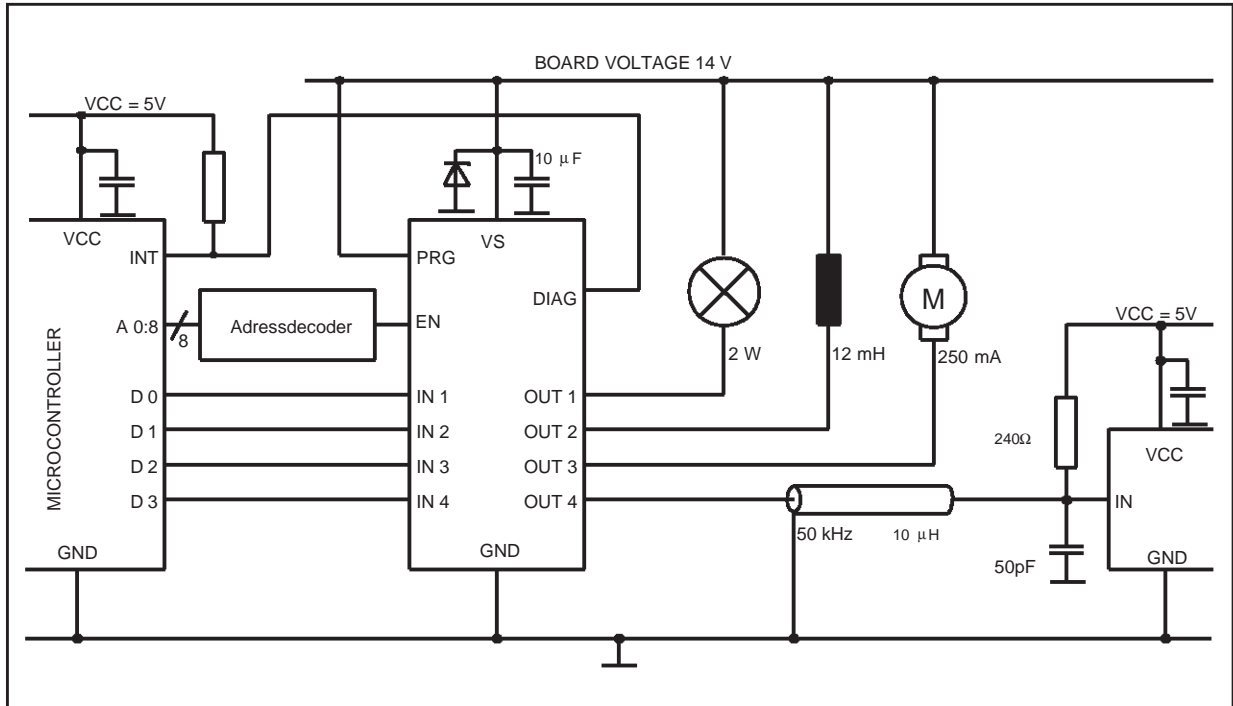

DIM.	mm			inch		
	MIN.	TYP.	MAX.	MIN.	TYP.	MAX.
A	2.35		2.65	0.093		0.104
A1	0.1		0.3	0.004		0.012
B	0.33		0.51	0.013		0.020
C	0.23		0.32	0.009		0.013
D	12.6		13	0.496		0.512
E	7.4		7.6	0.291		0.299
e		1.27			0.050	
H	10		10.65	0.394		0.419
h	0.25		0.75	0.010		0.030
L	0.4		1.27	0.016		0.050
K	0° (min.)8° (max.)					

OUTLINE AND MECHANICAL DATA

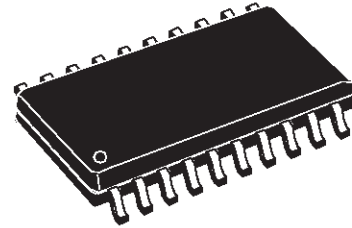

SO20

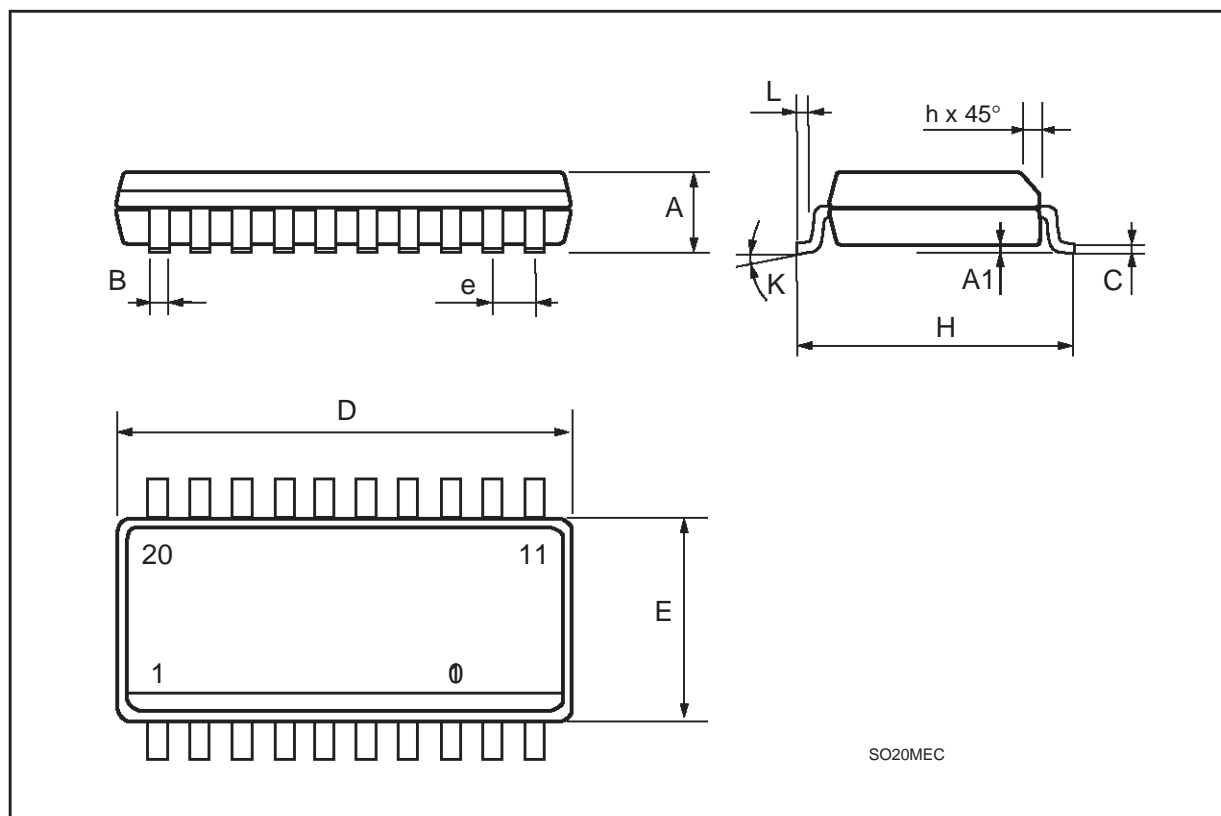

Information furnished is believed to be accurate and reliable. However, STMicroelectronics assumes no responsibility for the consequences of use of such information nor for any infringement of patents or other rights of third parties which may result from its use. No license is granted by implication or otherwise under any patent or patent rights of STMicroelectronics. Specification mentioned in this publication are subject to change without notice. This publication supersedes and replaces all information previously supplied. STMicroelectronics products are not authorized for use as critical components in life support devices or systems without express written approval of STMicroelectronics.

The ST logo is a registered trademark of STMicroelectronics

© 2000 STMicroelectronics – Printed in Italy – All Rights Reserved

STMicroelectronics GROUP OF COMPANIES

Australia - Brazil - China - Finland - France - Germany - Hong Kong - India - Italy - Japan - Malaysia - Malta - Morocco - Singapore - Spain - Sweden - Switzerland - United Kingdom - U.S.A.

<http://www.st.com>