

## QUAD LOW SIDE DRIVER

- WIDE OPERATING SUPPLY VOLTAGE RANGE FROM 4.5V UP TO 32V FOR TRANSIENT 45V
- VERY LOW STANDBY QUIESCENT CURRENT TYPICALLY  $< 2\mu\text{A}$
- INPUT TO OUTPUT SIGNAL TRANSFER FUNCTION PROGRAMMABLE
- HIGH SIGNAL RANGE FROM -14V UP TO 45V FOR ALL INPUTS
- 3.3V CMOS COMPATIBLE INPUTS
- DEFINED OUTPUT OFF STATE FOR OPEN INPUTS
- FOUR OPEN DRAIN DMOS OUTPUTS, WITH  $R_{\text{DSon}} = 1.5\Omega$  FOR  $V_{\text{S}} > 6\text{V}$  AT  $25^\circ\text{C}$
- OUTPUT CURRENT LIMITATION
- CONTROLLED OUTPUT SLOPE FOR LOW EMI
- OVERTEMPERATURE PROTECTION FOR EACH CHANNEL
- INTEGRATED OUTPUT CLAMPING FOR FAST INDUCTIVE RECIRCULATION  $V_{\text{FB}} > 45\text{V}$

**MULTIPOWER BCD TECHNOLOGY**

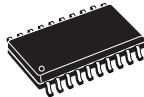

**SO20 (12+4+4)**

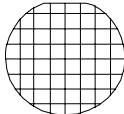

**DIE**

**ORDERING NUMBERS:**

<b>L9333MD</b>	(SO20 12+4+4)
<b>L9333DIE1</b>	(DIE)

- STATUS MONITORING FOR
  - OVERTEMPERATURE
  - DISCONNECTED GROUND OR SUPPLY VOLTAGE

### DESCRIPTION

The L9333 is a monolithic integrated quad low side driver. It is intended to drive lines, lamps or relays in automotive or industrial applications.

### BLOCK DIAGRAM

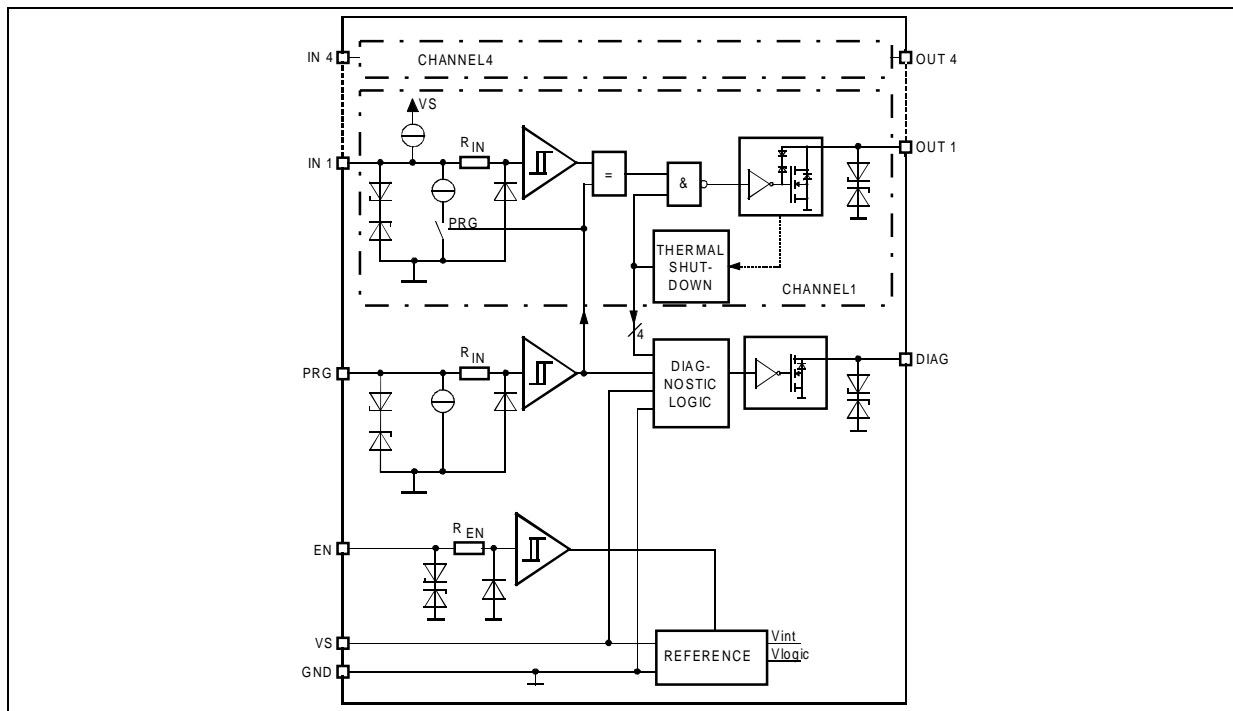

## PIN CONNECTION (Top view)

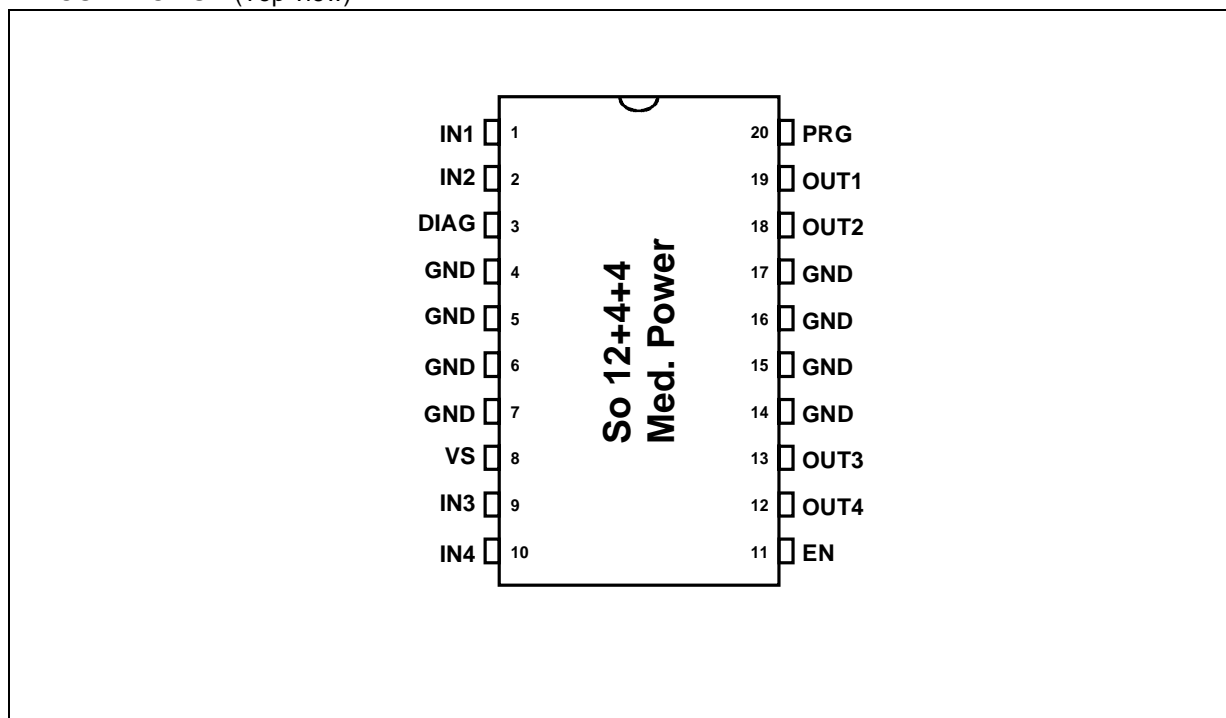

## PIN FUNCTION

Pin N°	Pin Name	Description
1	IN 1	Input 1
2	IN 2	Input 2
3	DIAG	Diagnostic
4, 5, 6, 7, 14, 15, 16, 17	GND	Ground
8	VS	Supply Voltage
9	IN 3	Input 3
10	IN 4	Input 4
11	EN	Enable
12	OUT4	OUTPUT4
13	OUT 3	OUTPUT 3
18	OUT 2	OUTPUT 2
19	OUT 1	OUTPUT 1
20	PRG	Programming

**ABSOLUTE MAXIMUM RATINGS**

Symbol	Parameter	Value	Unit
$V_S$	Supply voltage DC	-0.3 to 32	V
	Supply voltage Pulse (T = 400ms)	-0.3 to 45	V
$dV_S/dt$	Supply voltage transient	-10 to +10	V/ $\mu$ s
$V_{IN}$ , $V_{EN}$ , $V_{PRG}$	Input, Enable, Programming Pin voltage	-14 to 45	V
$V_{OUT}$	Output voltage	-0.3 to 45 <sup>1)</sup>	V
$V_{DIAG}$	Diagnostic output voltage	-0.3 to 45	V

Note 1) : In flyback phase the output voltage can reach 60V.

**ESD - PROTECTION**

Parameter	Value against GND	Unit
Supply pins and signal pins	$\pm 2$	KV
Output pins	$\pm 4$	KV

Note: Human-Body-Model according to MIL 883C. The device withstand ST1 class level.

**THERMAL DATA**

Symbol	Parameter	Min	Typ	Max	Unit
$T_{JSD}$	Temperature shutdown threshold	175		220	$^{\circ}$ C
$T_{JSDhys}$	Temperature shutdown hysteresis		20		K
<b>SO 12+4+4</b>					
$R_{th(j-p)}$	Thermal resistance junction to pins			15	$^{\circ}$ C/W
$R_{th(j-a)}$	Thermal resistance junction to ambient <sup>2)</sup>			50	$^{\circ}$ C/W

Note 2) : With 6cm<sup>2</sup> on board heat sink area.

**LIFE TIME**

Symbol	Parameter	Condition	Value	Unit
$t_B$	useful life time	$V_S \leq 14V$ EN = low	20	years
$t_b$	operating life time	$4.5V \leq V_S \leq 32V$ EN = high	5000	hours

**OPERATING RANGE:**

Within the operating range the IC operates as described in the circuit description, including the diagnostic table.

Symbol	Parameter	Condition	Min	Max	Unit
V <sub>S</sub>	Supply voltage		4.5	32	V
V <sub>IN</sub> , V <sub>EN</sub> , V <sub>PRG</sub>	Input voltage		-14	45	V
V <sub>OUT</sub>	Output voltage	Voltage will be limited by internal Z-Diode clamping	-0.3	60	V
V <sub>DIAG</sub>	Diagnostic output voltage		-0.3	45	V
T <sub>J</sub>	Junction temperature		-40	150	°C

**ELECTRICAL CHARACTERISTICS**

The electrical characteristics are valid within the defined Operating Conditions, unless otherwise specified. The function is guaranteed by design until T<sub>JSDon</sub> switch-on-threshold.

Symbol	Parameter	Test Condition	Min.	Typ.	Max.	Unit
<b>SUPPLY</b>						
I <sub>Q</sub>	Quiescent current	V <sub>S</sub> ≤ 14V; V <sub>EN</sub> ≤ 0.3V T <sub>amb</sub> 85 °C		< 2	10	µA
		V <sub>S</sub> ≤ 14V; V <sub>EN</sub> ≤ 0.3V T <sub>a</sub> 150°C			50	µA
		V <sub>S</sub> ≤ 14V; EN = high, Output = off EN = high, Output = on		1	2 3.5	mA mA
<b>Inputs, IN1 - IN4; Programming, PRG</b>						
V <sub>INlow</sub>	Input voltage LOW		-14		1	V
V <sub>INhigh</sub>	Input voltage HIGH		2		45	V
I <sub>IN</sub>	Input current	0V ≤ V <sub>IN</sub> ≤ 45V <sup>3)</sup>	-25		50	µA
R <sub>IN</sub>	Input impedance	V <sub>IN</sub> < 0V; V <sub>IN</sub> > V <sub>S</sub>	10	60		kΩ

Note 3) : Current direction depends on the programming setting (PRG=high leads into a positive current see also Blockdiagram page 1)

<b>Enable EN</b>						
V <sub>ENlow</sub>	Input voltage LOW		-14		1	V
V <sub>ENhigh</sub>	Input voltage HIGH		2		45	V
R <sub>EN</sub>	Input impedance	-14V < V <sub>EN</sub> < 1.5V	5			kΩ
I <sub>EN</sub>	Input current	1.5V < V <sub>EN</sub> < 45V	5		80	µA

## ELECTRICAL CHARACTERISTICS (continued)

Symbol	Parameter	Test Condition	Min.	Typ.	Max.	Unit
<b>Outputs OUT1- OUT4</b>						
R <sub>DSon</sub>	Output ON-resistor	V <sub>S</sub> > 6V, I <sub>O</sub> = 0.3A		1.7	3.8	Ω
I <sub>OLeak</sub>	Leakage current	V <sub>O</sub> = V <sub>S</sub> = 14V; T <sub>a</sub> < 125°C		1	5	μA
		V <sub>O</sub> = V <sub>S</sub> = 14V; T <sub>a</sub> < 150°C			25	μA
V <sub>OClamp</sub>	Output voltage during clamping	E <sub>FB</sub> ≤ 2mJ; 10 mA < I <sub>O</sub> < 0.3A	45	52	60	V
I <sub>OSC</sub>	Short-circuit current	V <sub>S</sub> > 6V	400	700	1000	mA
C <sub>O</sub>	internal output capacities	V <sub>O</sub> > 4.5V			100	pF
<b>Diagnostic Output DIAG</b>						
V <sub>Dlow</sub>	Output voltage LOW	I <sub>DL</sub> = 0.6mA			0.8	V
I <sub>Dmax</sub>	Max. output current	internal current limitation; V <sub>D</sub> = 14V	1	5	15	mA
I <sub>DLeak</sub>	Leakage current	V <sub>D</sub> = V <sub>S</sub> = 14 V; T <sub>a</sub> < 125 °C		0.1	1	μA
		V <sub>D</sub> = V <sub>S</sub> = 14 V; T <sub>a</sub> < 150 °C			5	μA
<b>Timing Characteristics <sup>4)</sup></b>						
t <sub>d,on</sub>	On delay time	V <sub>S</sub> = 14V		2	3.5	μs
t <sub>d,off</sub>	Off delay time	C <sub>ext</sub> = 0F; L <sub>ext</sub> = 0H		3	4.5	μs
t <sub>set</sub>	Enable settling time	only testing condition			20	μs
t <sub>d,DIAG</sub>	ON or OFF Diagnostic delay time	10mA ≤ I <sub>O</sub> ≤ 200mA			10	μs
S <sub>out</sub>	Output voltage slopes		2.5	9	16	V/μs

Note : All parameters are measured at 125°C.

Note 4) : See also Fig.3 Timing Characteristics

Figure 1. Timing Characteristics

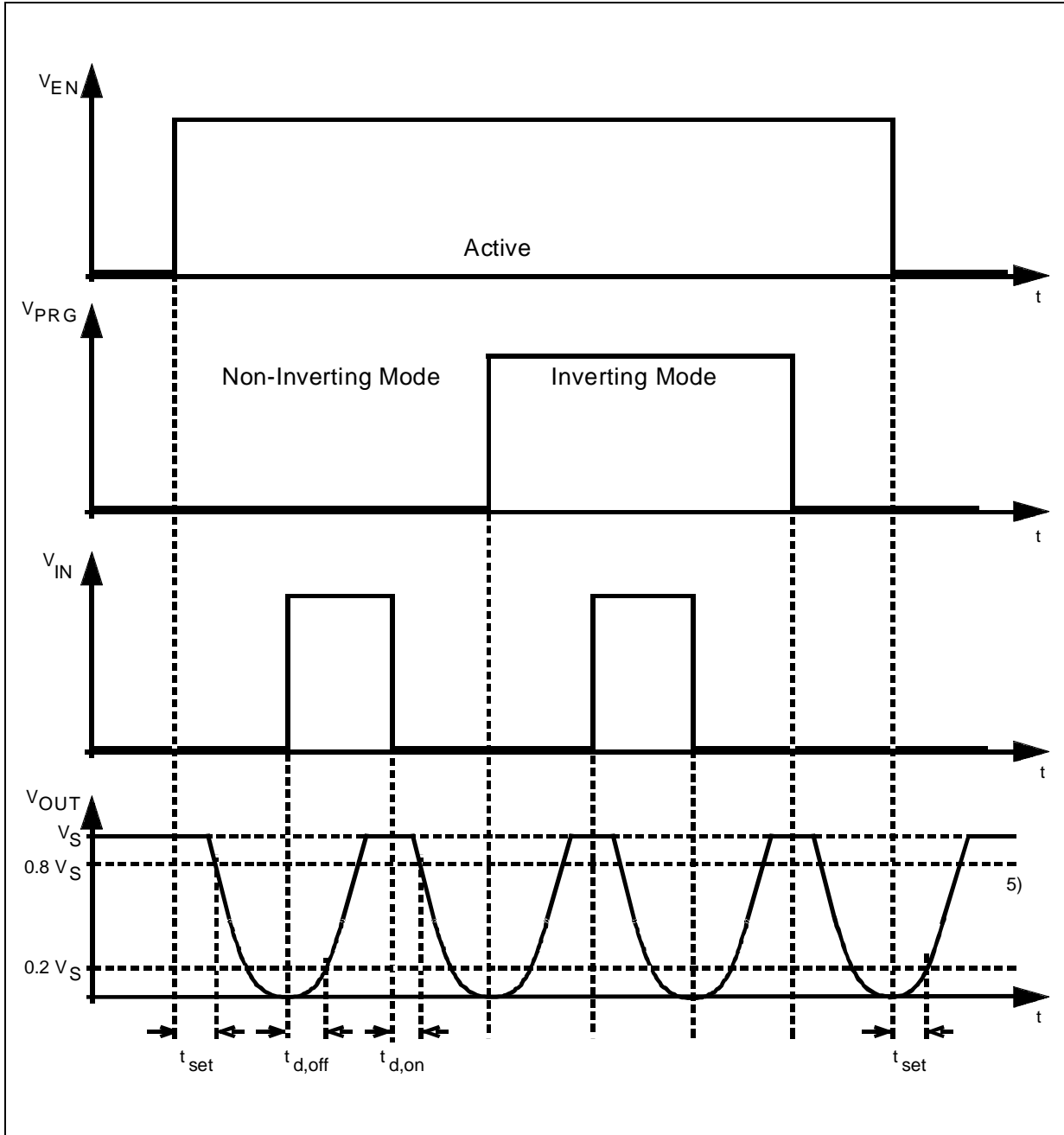

Note 5) : Output voltage slope not controlled for enable low!

## FUNCTIONAL DESCRIPTION

The L9333 is a quad low side driver for lines, lamps or inductive loads in automotive and industrial applications.

The logic input levels are 3.3V CMOS compatible. This allows the device to be driven directly by a microcontroller. For the noise immunity, all input thresholds have a hysteresis of typ. 100mV. Each input (IN, EN and PRG) is protected to withstand voltages from -14V to 45V. The device is activated with a 'high' signal on ENable. ENable 'low' switches the device into the sleep mode. In this mode the quiescent current is typically less than 2 $\mu$ A. A high signal on PRoGramming input changes the signal transfer polarity from noninverting to the inverting mode. This pin can be connected either to V<sub>S</sub> or GND. If these pins are not connected, the forced status of the PRG and EN pin is low. For packaged applications it is still recommended to connect all input pins to ground respective VS to avoid EMC influence. The forced condition leads to a mode change if the PRG pin was high before the interruption. Independent of the PRoGramming input, the OUTput switches off, if the signal INput pin is not connected. This function is verified using a leakage current of 5 $\mu$ A (sink for PRG=high; source for PRG=low) during circuit test.

Each output driver has a current limitation of min 0.4A and an independent thermal shut-down. The thermal shut-down deactivates that output, which exceeds temperature switch off level. When the junction temperature decreases 20K below this temperature threshold the output will be activated again. This 20K is the hysteresis of the thermal shutdown function. The Gates, of the output DMOS transistors are charged and discharged with a current source. Therefore the output slope is limited. This reduces the electromagnetic radiation. For inductive loads an output voltage clamp of typically 52V is implemented.

The DIAGnostic is an open drain output. The logic status depends on the PRoGramming pin. If the PRG pin is 'low' the DIAG output becomes low, if the device works correctly. At thermal shut-down of one channel or if the ground is disconnected the DIAGnostic output becomes high. If the PRG pin is 'high' this output is switched off at normal function and switched on at overtemperature. For the fault condition of interrupted ground, the potential of VS and Diagnostic should be equal.

## DIAGNOSTIC TABLE

Pins	EN	PRG	IN	OUT	DIAG
Normal function	H	L	L	L (on)	L (on)
	H	L	H	H (off)	L (on)
	H	H	L	H (off)	H (off)
	H	H	H	L (on)	H (off)
	L	X	X	H (off)	H (off)
Overtemperature, disconnected ground or supply voltage	H	L	X	H (off) *	H (off)
Overtemperature	H	H	X	H(off) *	L(on)

X = not relevant

\* selective for each channel at overtemperature

Figure 2. Application for Inverting Transfer Polarity

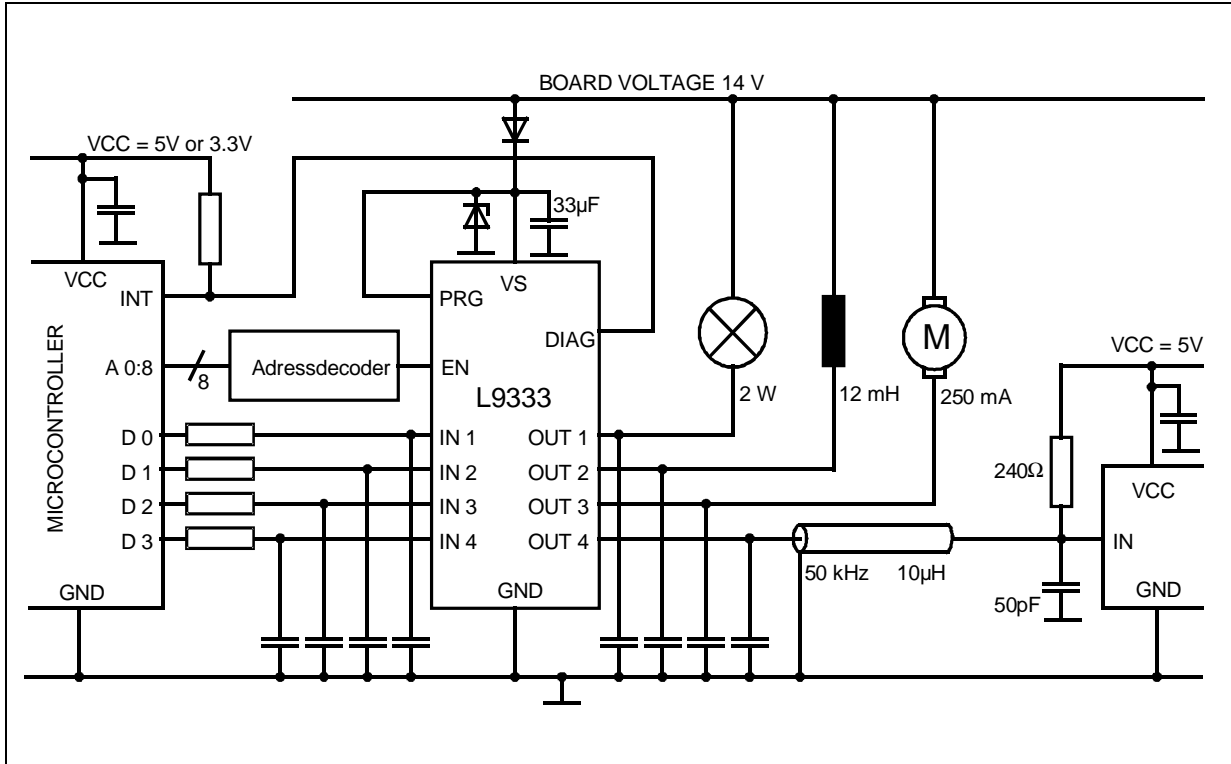
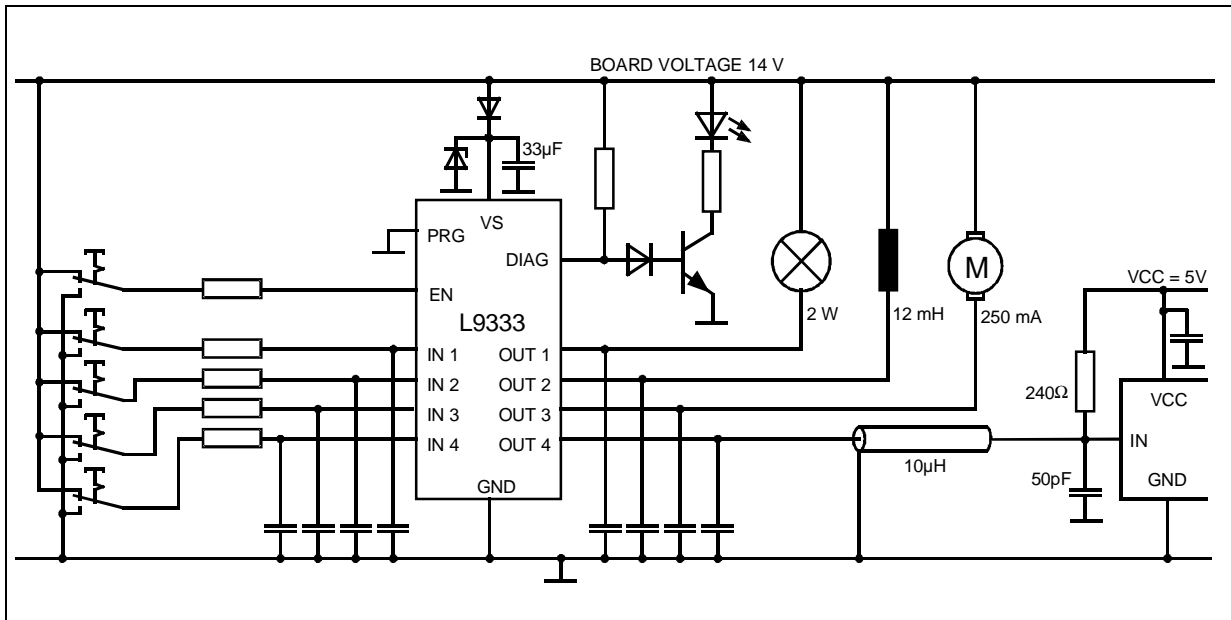

Figure 3. Application for non Inverting Transfer Polarity



Note We recommend to use the device for driving inductive loads with flyback energy  $E_{FB} \leq 2mJ$ .



---

**EMC SPECIFICATION****EMS (electromagnetic susceptibility)****Measurement setup:**

DUT mounted on a specific application board is driven in a typical application circuit (see below). Two devices are stimulated by a generator to read and write bus signals. They will be monitored externally to ensure proper function.

**Measurement method:**

- a) The two bus lines are transferred 2m under a terminated stripline. That's where they were exposed to the RF-field. Stripline setup and measurement method is described in DIN 40839-4 or ISO 11452-5.
- b) DUT mounted on the same application board is exposed to RF through the tophole of a TEM-cell. Measurement method according SAE J1752.
- c) The two bus lines are transferred into a BCI current injection probe. Setup and measurement method is described in ISO 11452-4.

**Failure criteria:**

Failure monitoring is done by envelope measurement of the logic signals with a LeCroy oscilloscope with acceptance levels of 20% in amplitude and 2% time.

**Limits:**

The device is measured within the described setup and limits without fail function.

The Electromagnetic Susceptivity is not tested in production.

- a) Field strength under stripline of > 250V/m in the frequency range 1 - 400MHz modulation: AM 1kHz 80%.
- b) Field strength in TEM-cell of > 500V/m in the frequency range 1 - 400MHz modulation: AM 1kHz 80%.
- c) RF-currents with BCI of > 100mA in the frequency range 1 - 400MHz modulation: AM 1kHz 80%.

**Measured Circuit**

The EMS of the device was verified in the below described setup.

Figure 4.

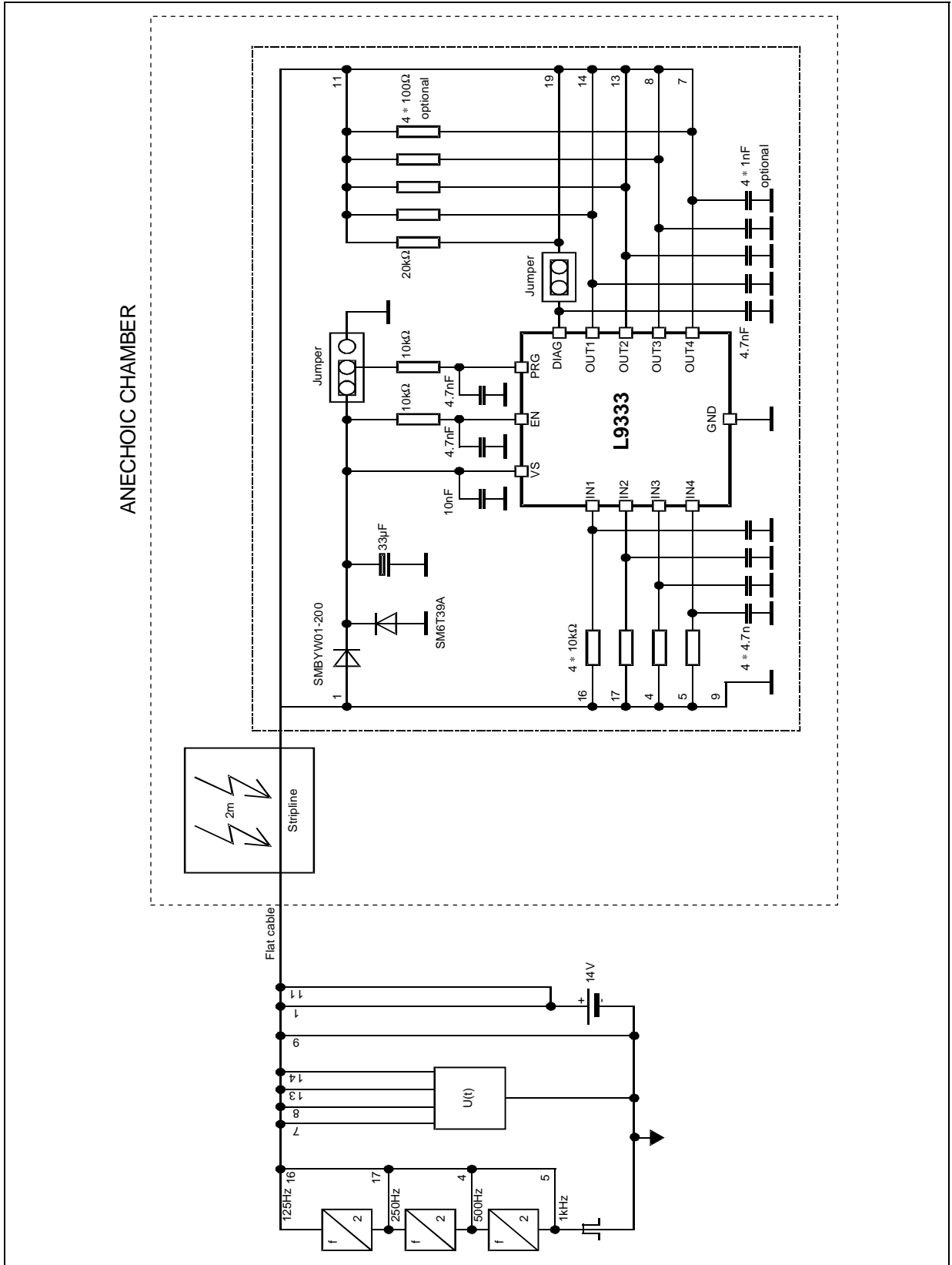

DIM.	mm			inch		
	MIN.	TYP.	MAX.	MIN.	TYP.	MAX.
A	2.35		2.65	0.093		0.104
A1	0.1		0.3	0.004		0.012
B	0.33		0.51	0.013		0.020
C	0.23		0.32	0.009		0.013
D	12.6		13	0.496		0.512
E	7.4		7.6	0.291		0.299
e		1.27			0.050	
H	10		10.65	0.394		0.419
h	0.25		0.75	0.010		0.030
L	0.4		1.27	0.016		0.050
K	0° (min.)8° (max.)					

## OUTLINE AND MECHANICAL DATA

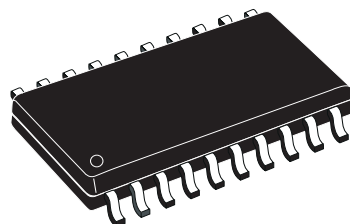

**SO20 (12+4+4)**

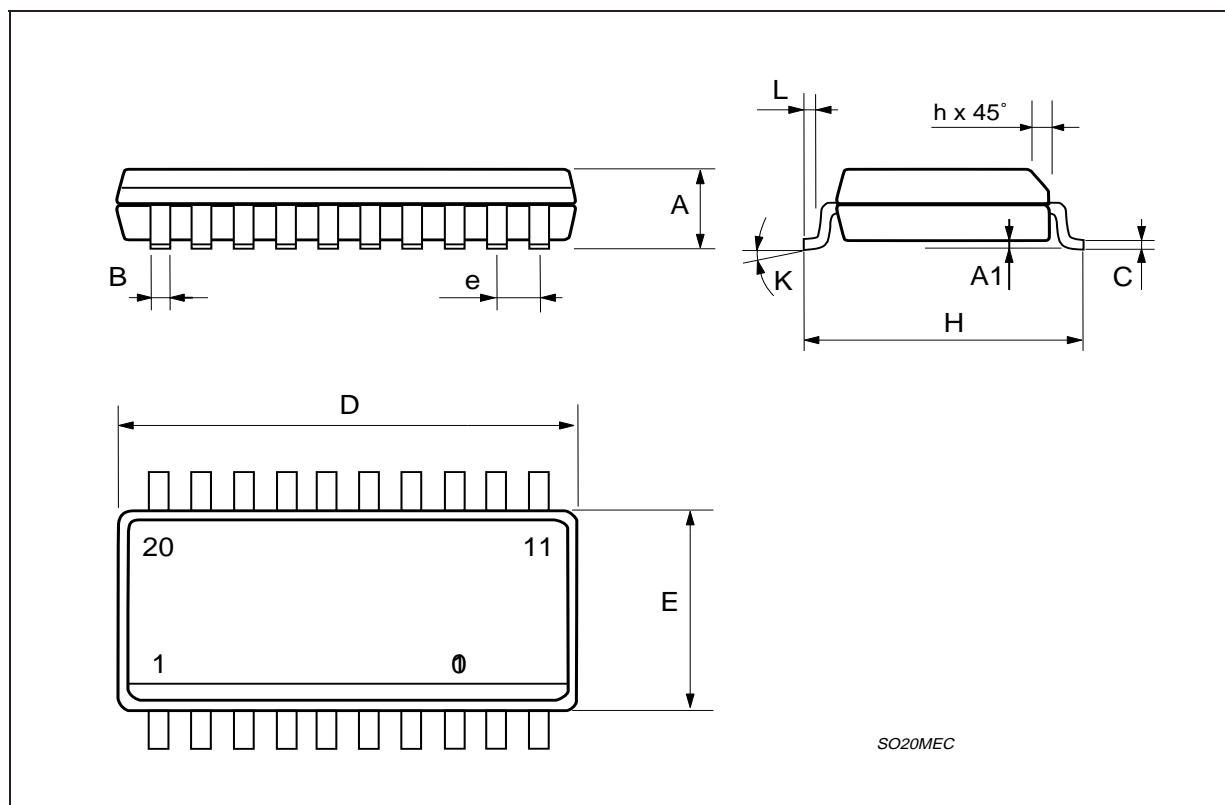

**L9333**

SIZE 2.53x2.37mm

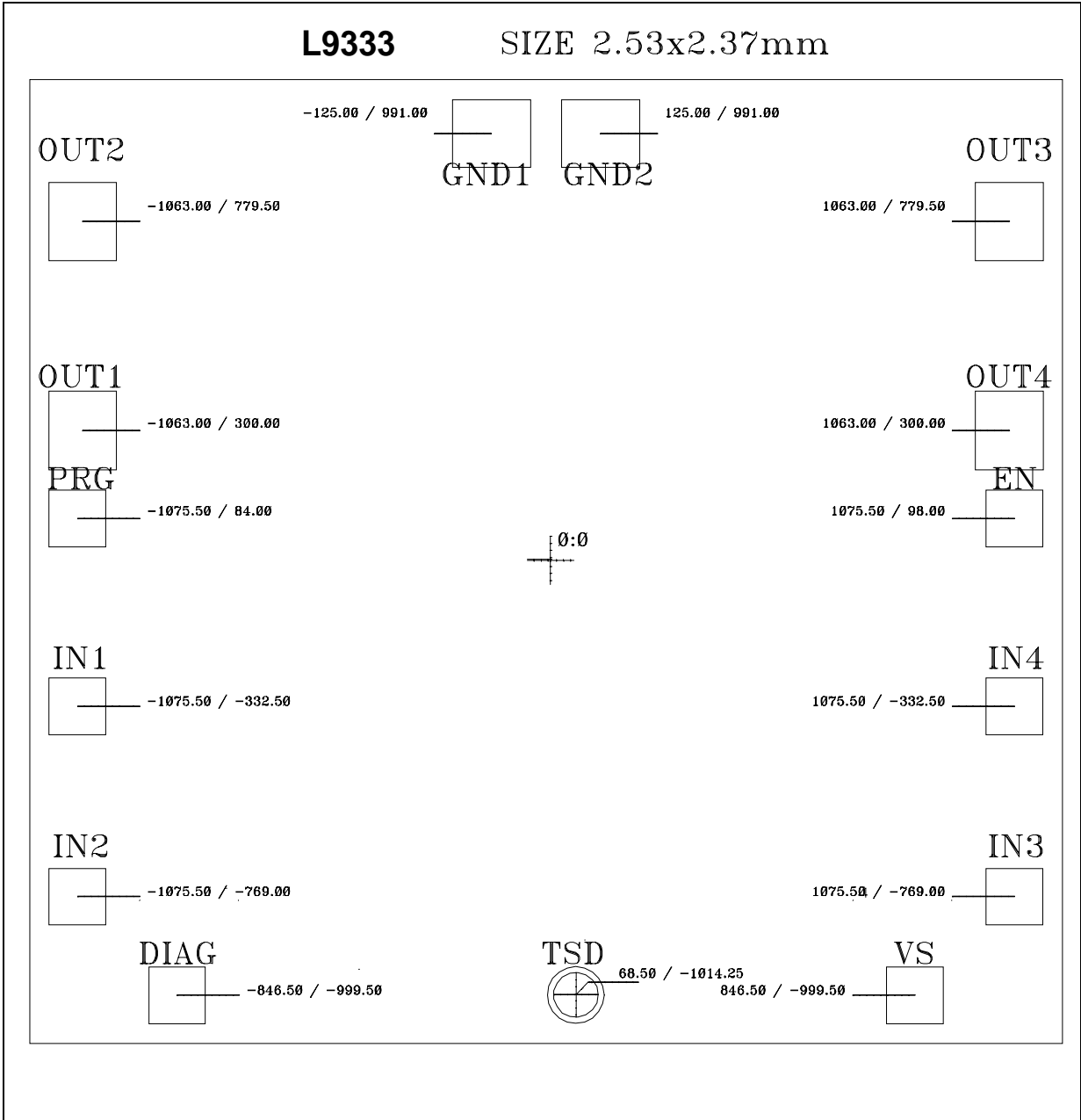

Information furnished is believed to be accurate and reliable. However, STMicroelectronics assumes no responsibility for the consequences of use of such information nor for any infringement of patents or other rights of third parties which may result from its use. No license is granted by implication or otherwise under any patent or patent rights of STMicroelectronics. Specifications mentioned in this publication are subject to change without notice. This publication supersedes and replaces all information previously supplied. STMicroelectronics products are not authorized for use as critical components in life support devices or systems without express written approval of STMicroelectronics.

The ST logo is a registered trademark of STMicroelectronics  
© 2001 STMicroelectronics - All Rights Reserved

STMicroelectronics GROUP OF COMPANIES  
Australia - Brazil - China - Finland - France - Germany - Hong Kong - India - Italy - Japan - Malaysia - Malta - Morocco - Singapore - Spain  
- Sweden - Switzerland - United Kingdom - U.S.A.  
<http://www.st.com>

