

3 A step-down switching regulator

Datasheet – production data

Features

- 3 A DC output current
- 4.5 V to 38 V input voltage
- Output voltage adjustable from 0.6 V
- 250 kHz switching frequency, programmable up to 1 MHz
- Internal soft-start and enable
- Low dropout operation: 100% duty cycle
- Voltage feed-forward
- Zero load current operation
- Overcurrent and thermal protection
- HSOP8 package
- Guarantee overtemperature range (-40 °C to 125 °C)

Applications

- Automotive:
 - Car audio, car infotainment
- Industrial:
 - PLD, PLA, FPGA, chargers
- Networking: XDSL, modems, DC-DC modules
- Computer:
 - Optical storage, hard disk drive, printers
- LED driving

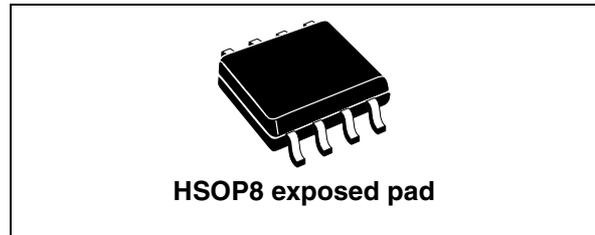

Description

The L7986TA is a step-down switching regulator with 3.7 A (min.) current limited embedded power MOSFET, so it is able to deliver up to 3 A current to the load depending on the application conditions.

The input voltage can range from 4.5 V to 38 V, while the output voltage can be set starting from 0.6 V to V_{IN} .

Requiring a minimum set of external components, the device includes an internal 250 kHz switching frequency oscillator that can be externally adjusted up to 1 MHz.

The HSOP package with exposed pad allows the reduction of R_{thJA} down to 40 °C/W.

Contents

1	Pin settings	4
1.1	Pin connection	4
1.2	Pin description	4
2	Maximum ratings	5
3	Thermal data	5
4	Electrical characteristics	6
5	Functional description	8
5.1	Oscillator and synchronization	9
5.2	Soft-start	11
5.3	Error amplifier and compensation	12
5.4	Overcurrent protection	13
5.5	Enable function	14
5.6	Hysteretic thermal shutdown	14
6	Application information	15
6.1	Input capacitor selection	15
6.2	Inductor selection	16
6.3	Output capacitor selection	17
6.4	Compensation network	18
6.4.1	Type III compensation network	20
6.4.2	Type II compensation network	24
6.5	Thermal considerations	27
6.6	Layout considerations	29
6.7	Application circuit	31
7	Application ideas	35
7.1	Positive buck-boost	35
7.2	Inverting buck-boost	37

8	Package mechanical data	39
9	Ordering information	41
10	Revision history	42

1 Pin settings

1.1 Pin connection

Figure 1. Pin connection (top view)

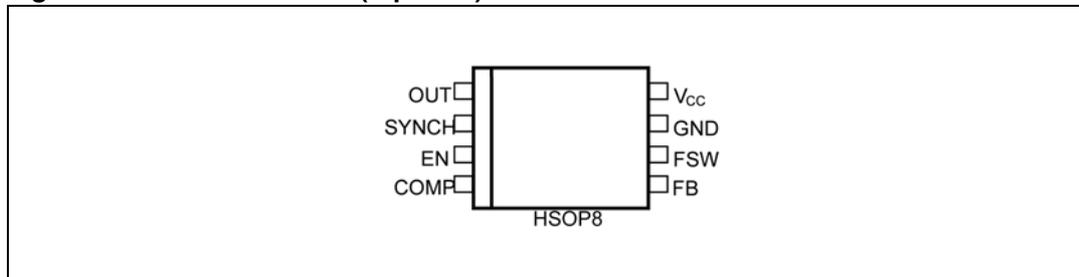

1.2 Pin description

Table 1. Pin description

N.	Type	Description
1	OUT	Regulator output
2	SYNCH	Master/slave synchronization. When it is left floating, a signal with a phase shift of half a period, with respect to the power turn-on, is present at the pin. When connected to an external signal at a frequency higher than the internal one, the device is synchronized by the external signal, with zero phase shift. Connecting together the SYNCH pin of two devices, the one with a higher frequency works as master and the other as slave; so the two powers turn-ons have a phase shift of half a period.
3	EN	A logical signal (active high) enables the device. With EN higher than 1.2 V the device is ON and with EN lower than 0.3 V the device is OFF.
4	COMP	Error amplifier output to be used for loop frequency compensation.
5	FB	Feedback input. By connecting the output voltage directly to this pin the output voltage is regulated at 0.6 V. To have higher regulated voltages an external resistor divider is required from V _{OUT} to the FB pin.
6	F _{SW}	The switching frequency can be increased connecting an external resistor from the FSW pin and ground. If this pin is left floating, the device works at its free-running frequency of 250 kHz.
7	GND	Ground
8	V _{CC}	Unregulated DC input voltage.

2 Maximum ratings

Table 2. Absolute maximum ratings

Symbol	Parameter		Value	Unit
V _{CC}	Input voltage		45	V
OUT	Output DC voltage		-0.3 to V _{CC}	
F _{SW} , COMP, SYNCH	Analog pin		-0.3 to 4	
EN	Enable pin		-0.3 to V _{CC}	
FB	Feedback voltage		-0.3 to 1.5	
P _{TOT}	Power dissipation at T _A < 60 °C	HSOP	2	W
T _J	Junction temperature range		-40 to 150	°C
T _{stg}	Storage temperature range		-55 to 150	°C

3 Thermal data

Table 3. Thermal data

Symbol	Parameter		Value	Unit
R _{thJA}	Maximum thermal resistance junction-ambient ⁽¹⁾	HSOP8	40	°C/W

1. Package mounted on demonstration board.

4 Electrical characteristics

T_J=-40 °C to 125 °C, V_{CC}=12 V, unless otherwise specified.

Table 4. Electrical characteristics

Symbol	Parameter	Test condition	Values			Unit
			Min.	Typ.	Max.	
V _{CC}	Operating input voltage range		4.5		38	V
V _{CCON}	Turn-on V _{CC} threshold				4.5	
V _{CCHYS}	V _{CC} UVLO hysteresis		0.1		0.4	
R _{DS(on)}	MOSFET on resistance			200	400	mΩ
I _{LIM}	Maximum limiting current	T _J =25 °C	3.7	4.2	4.7	A
			3.5		4.7	
Oscillator						
F _{SW}	Switching frequency		210	250	275	KHz
V _{FSW}	FSW pin voltage			1.254		V
D	Duty Cycle		0		100	%
F _{ADJ}	Adjustable switching frequency	R _{FSW} =33 kΩ		1000		KHz
Dynamic characteristics						
V _{FB}	Feedback voltage	4.5 V < V _{CC} < 38 V	0.582	0.6	0.618	V
DC characteristics						
I _Q	Quiescent current	Duty Cycle=0, V _{FB} =0.8 V			2.4	mA
I _{QST-BY}	Total standby quiescent current			20	30	μA
Enable						
V _{EN}	EN threshold voltage	Device OFF level			0.3	V
		Device ON level	1.2			
I _{EN}	EN current	EN=V _{CC}		7.5	10	μA
Soft-start						
T _{SS}	Soft-start duration	FSW pin floating	7.4	8.2	9.7	ms
		F _{SW} =1 MHz, R _{FSW} =33 kΩ		2		

Table 4. Electrical characteristics (continued)

Symbol	Parameter	Test condition	Values			Unit
			Min.	Typ.	Max.	
Error amplifier						
V_{CH}	High level output voltage	$V_{FB} < 0.6 \text{ V}$	3			V
V_{CL}	Low level output voltage	$V_{FB} > 0.6 \text{ V}$			0.1	
$I_{O \text{ SOURCE}}$	Source COMP pin	$V_{FB} = 0.5 \text{ V}$, $V_{COMP} = 1 \text{ V}$		19		mA
$I_{O \text{ SINK}}$	Sink COMP pin	$V_{FB} = 0.7 \text{ V}$, $V_{COMP} = 1 \text{ V}$		30		mA
G_V	Open-loop voltage gain	(1)		100		dB
Synchronization function						
$V_{S_IN,HI}$	High input voltage		2		3.3	V
$V_{S_IN,LO}$	Low input voltage				1	
$t_{S_IN_PW}$	Input pulse width	$V_{S_IN,HI} = 3 \text{ V}$, $V_{S_IN,LO} = 0 \text{ V}$	100			ns
		$V_{S_IN,HI} = 2 \text{ V}$, $V_{S_IN,LO} = 1 \text{ V}$	300			
$I_{SYNCH,LO}$	Slave sink current	$V_{SYNCH} = 2.9 \text{ V}$		0.7	1	mA
$V_{S_OUT,HI}$	Master output amplitude	$I_{SOURCE} = 4.5 \text{ mA}$	2			V
$t_{S_OUT_PW}$	Output pulse width	SYNCH floating		110		ns
Protection						
T_{SHDN}	Thermal shutdown			150		°C
	Hysteresis			30		

1. Guaranteed by design.

5 Functional description

The L7986TA is based on a “voltage mode”, constant frequency control. The output voltage V_{OUT} is sensed by the feedback pin (FB) compared to an internal reference (0.6 V) providing an error signal that, compared to a fixed frequency sawtooth, controls the on- and off-time of the power switch.

The main internal blocks are shown in the block diagram in *Figure 2*. They are:

- A fully integrated oscillator that provides sawtooth to modulate the duty cycle and the synchronization signal. Its switching frequency can be adjusted by an external resistor. The voltage and frequency feed-forward are implemented.
- The soft-start circuitry to limit inrush current during the startup phase.
- The voltage mode error amplifier.
- The pulse width modulator and the relative logic circuitry necessary to drive the internal power switch.
- The high-side driver for embedded P-channel power MOSFET switch.
- The peak current limit sensing block, to handle overload and short-circuit conditions.
- A voltage regulator and internal reference. It supplies internal circuitry and provides a fixed internal reference.
- A voltage monitor circuitry (UVLO) that checks the input and internal voltages.
- A thermal shutdown block, to prevent thermal runaway.

Figure 2. Block diagram

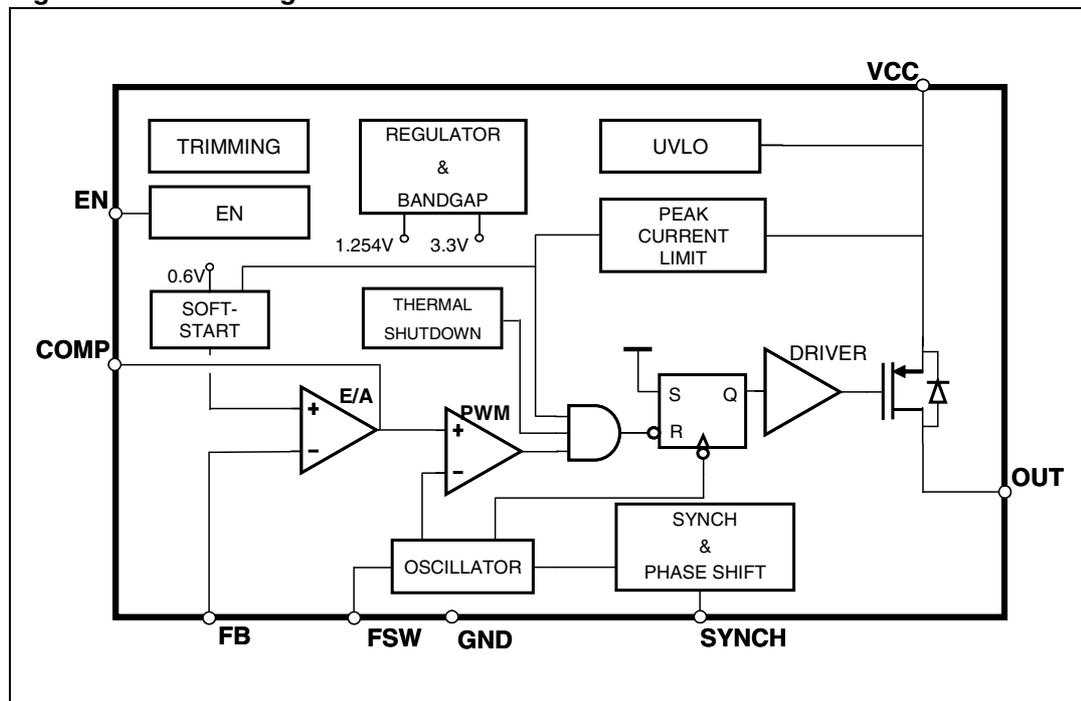

5.1 Oscillator and synchronization

Figure 3 shows the block diagram of the oscillator circuit. The internal oscillator provides a constant frequency clock. Its frequency depends on the resistor externally connect to the FSW pin. If the FSW pin is left floating, the frequency is 250 kHz; it can be increased as shown in *Figure 5* by an external resistor connected to ground.

To improve the line transient performance, keeping the PWM gain constant versus the input voltage, the voltage feed-forward is implemented by changing the slope of the sawtooth according to the input voltage change (see *Figure 4.a*).

The slope of the sawtooth also changes if the oscillator frequency is increased by the external resistor. In this way a frequency feed-forward is implemented (*Figure 4.b*) in order to keep the PWM gain constant versus the switching frequency (see *Section 6.4* for PWM gain expression).

On the SYNCH pin the synchronization signal is generated. This signal has a phase shift of 180° with respect to the clock. This delay is useful when two devices are synchronized connecting the SYNCH pins together. When SYNCH pins are connected, the device with a higher oscillator frequency works as master, so the slave device switches at the frequency of the master but with a delay of half a period. This minimizes the RMS current flowing through the input capacitor (see the L5988D datasheet).

Figure 3. Oscillator circuit block diagram

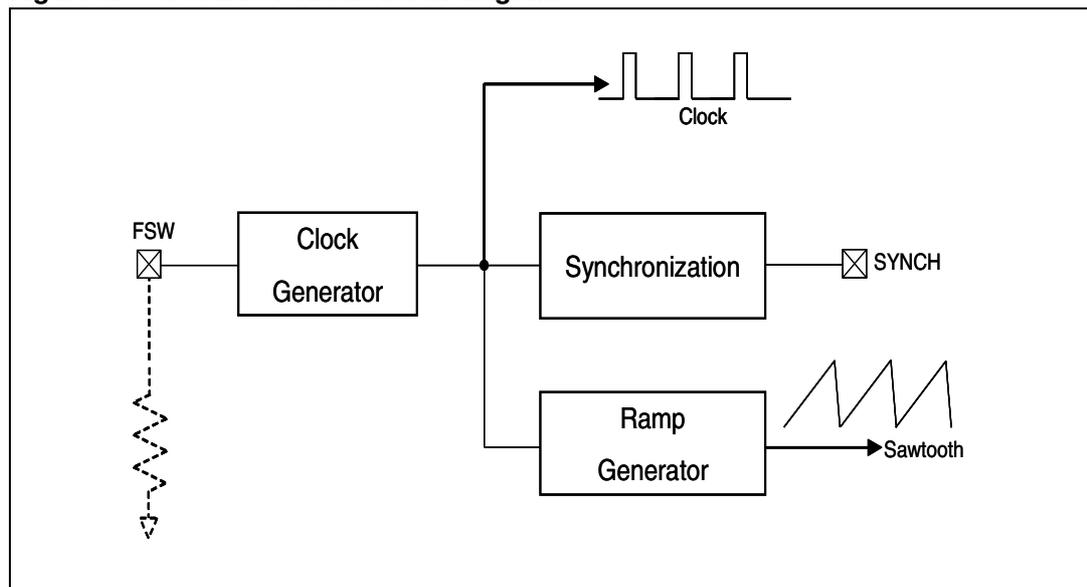

The device can be synchronized to work at a higher frequency feeding an external clock signal. The synchronization changes the sawtooth amplitude, changing the PWM gain (*Figure 4.c*). This change must be taken into account when the loop stability is studied. To minimize the change of the PWM gain, the free-running frequency should be set (with a resistor on the FSW pin) only slightly lower than the external clock frequency. This pre-adjusting of the frequency changes the sawtooth slope in order to render the truncation of sawtooth negligible, due to the external synchronization.

Figure 4. Sawtooth: voltage and frequency feed-forward; external synchronization

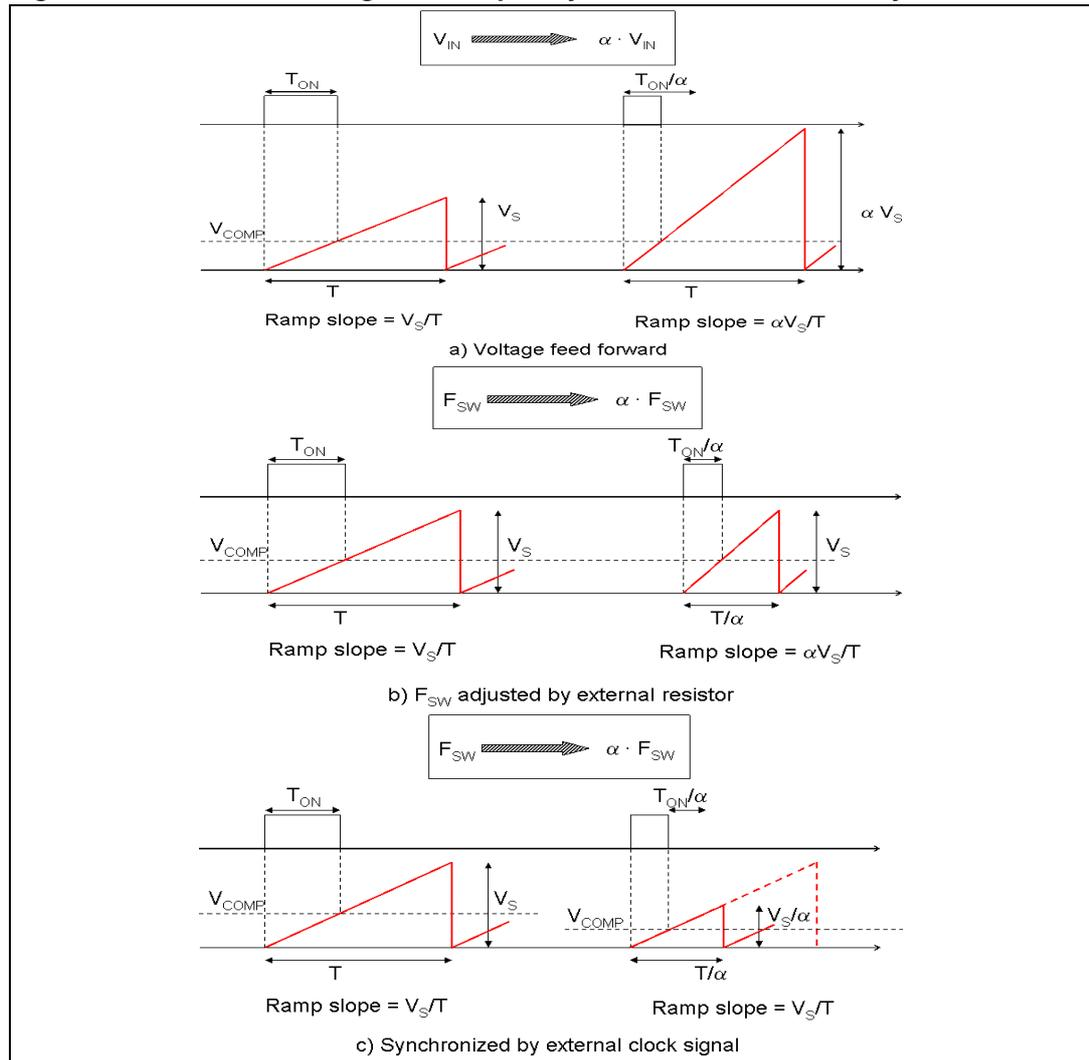
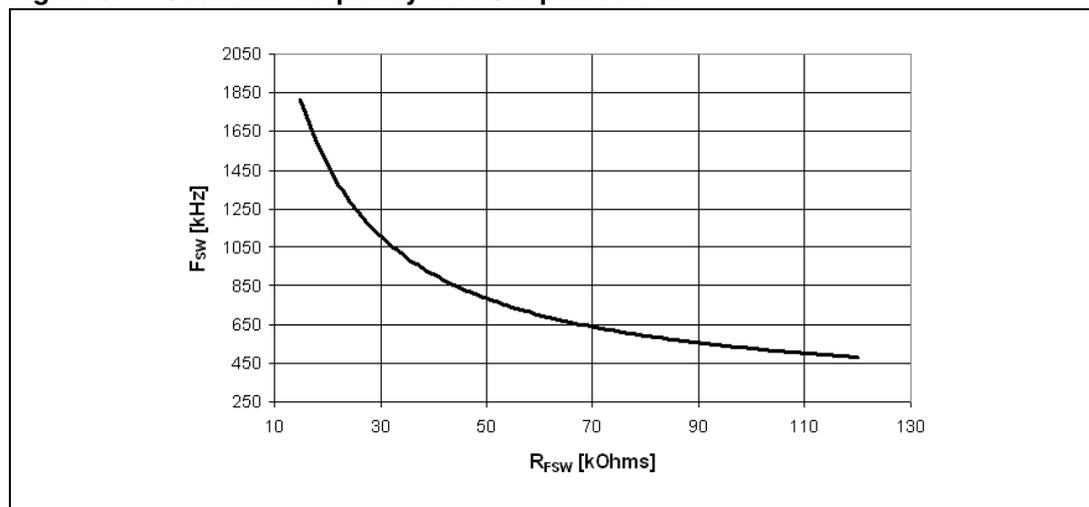

Figure 5. Oscillator frequency vs. FSW pin resistor



5.2 Soft-start

The soft-start is essential to assure correct and safe startup of the step-down converter. It avoids inrush current surge and makes the output voltage increase monotonically.

The soft-start is performed by a staircase ramp on the non-inverting input (V_{REF}) of the error amplifier. So the output voltage slew rate is:

Equation 1

$$SR_{OUT} = SR_{VREF} \cdot \left(1 + \frac{R1}{R2}\right)$$

where SR_{VREF} is the slew rate of the non-inverting input, while $R1$ and $R2$ is the resistor divider to regulate the output voltage (see [Figure 6](#)). The soft-start staircase consists of 64 steps of 9.5 mV each, from 0 V to 0.6 V. The time base of one step is of 32 clock cycles. So the soft-start time and then the output voltage slew rate depend on the switching frequency.

Figure 6. Soft-start scheme.

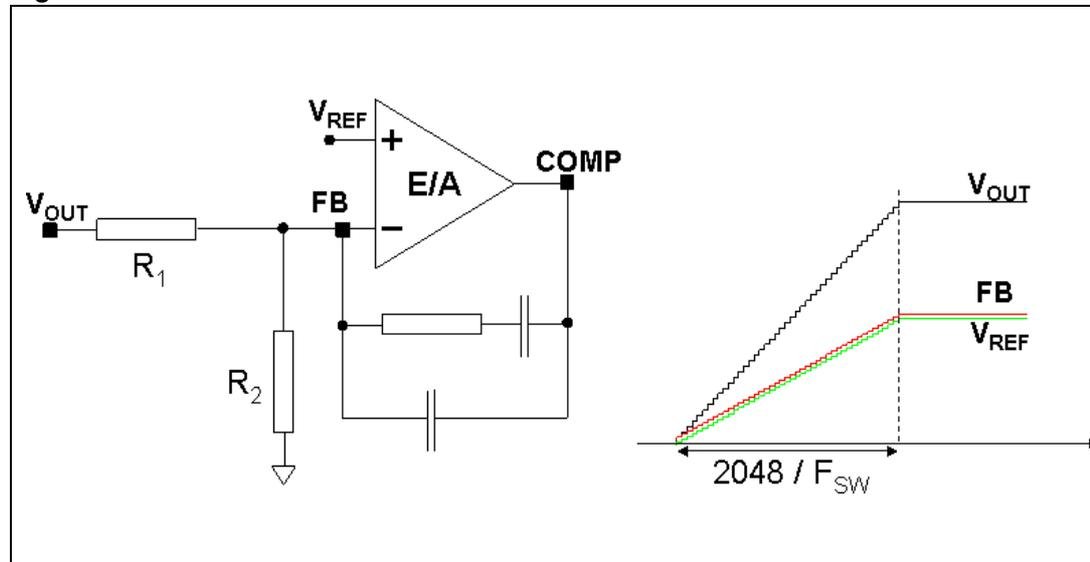

Soft-start time results:

Equation 2

$$SS_{TIME} = \frac{32 \cdot 64}{F_{SW}}$$

For example, with a switching frequency of 250 kHz the SS_{TIME} is 8 ms.

5.3 Error amplifier and compensation

The error amplifier (E/A) provides the error signal to be compared with the sawtooth to perform the pulse width modulation. Its non-inverting input is internally connected to a 0.6 V voltage reference, while its inverting input (FB) and output (COMP) are externally available for feedback and frequency compensation. In this device the error amplifier is a voltage mode operational amplifier, therefore, with high DC gain and low output impedance.

The uncompensated error amplifier characteristics are the following:

Table 5. Uncompensated error amplifier characteristics

Parameter	Value
Low frequency gain	100 dB
GBWP	4.5 MHz
Slew rate	7 V/μs
Output voltage swing	0 to 3.3 V
Maximum source/sink current	17 mA/25 mA

In continuous conduction mode (CCM), the transfer function of the power section has two poles due to the LC filter and one zero due to the ESR of the output capacitor. Different kinds of compensation networks can be used depending on the ESR value of the output capacitor. If the zero introduced by the output capacitor helps to compensate the double pole of the LC filter, a type II compensation network can be used. Otherwise, a type III compensation network must be used (see [Section 6.4](#) for details of the compensation network selection).

Anyway, the methodology to compensate the loop is to introduce zeroes to obtain a safe phase margin.

5.4 Overcurrent protection

The L7986TA implements overcurrent protection by sensing current flowing through the power MOSFET. Due to the noise created by the switching activity of the power MOSFET, the current sensing is disabled during the initial phase of the conduction time. This avoids an erroneous detection of a fault condition. This interval is generally known as “masking time” or “blanking time”. The masking time is about 200 ns.

If the overcurrent limit is reached, the power MOSFET is turned off implementing pulse-by-pulse overcurrent protection. In the overcurrent condition, the device can skip turn-on pulses in order to keep the output current constant and equal to the current limit. If, at the end of the “masking time”, the current is higher than the overcurrent threshold, the power MOSFET is turned off and one pulse is skipped. If, at the following switching on, when the “masking time” ends, the current is still higher than the overcurrent threshold, the device skips two pulses. This mechanism is repeated and the device can skip up to seven pulses. While, if at the end of the “masking time”, the current is lower than the overcurrent threshold, the number of skipped cycles is decreased by one unit (see [Figure 7](#)).

So, the overcurrent/short-circuit protection acts by switching off the power MOSFET and reducing the switching frequency down to one eighth of the default switching frequency, in order to keep constant the output current around the current limit.

This kind of overcurrent protection is effective if the output current is limited. To prevent the current from diverging, the current ripple in the inductor during the on-time must not be higher than the current ripple during the off-time. That is:

Equation 3

$$\frac{V_{IN} - V_{OUT} - R_{DSON} \cdot I_{OUT} - DCR \cdot I_{OUT}}{L \cdot F_{SW}} \cdot D = \frac{V_{OUT} + V_F + R_{DSON} \cdot I_{OUT} + DCR \cdot I_{OUT}}{L \cdot F_{SW}} \cdot (1 - D)$$

If the output voltage is shorted, $V_{OUT} \cong 0$, $I_{OUT} = I_{LIM}$, $D/F_{SW} = T_{ON_MIN}$, $(1-D)/F_{SW} \cong 1/F_{SW}$. So, from [Equation 3](#), the maximum switching frequency that guarantees to limit the current results:

Equation 4

$$F_{SW}^* = \frac{(V_F + DCR \cdot I_{LIM})}{(V_{IN} - (R_{DSON} + DCR) \cdot I_{LIM})} \cdot \frac{1}{T_{ON_MIN}}$$

With $R_{DSON} = 300 \text{ m}\Omega$, $DCR = 0.08 \text{ }\Omega$ the worst condition is with $V_{IN} = 38 \text{ V}$, $I_{LIM} = 3.7 \text{ A}$; the maximum frequency to keep the output current limited during the short-circuit results 88 kHz.

The pulse-by-pulse mechanism, which reduces the switching frequency down to one eighth the maximum F_{SW} , adjusted by the FSW pin, that assures a full effective output current limitation, is $88 \text{ kHz} \cdot 8 = 706 \text{ kHz}$.

If, with $V_{IN}=38\text{ V}$, the switching frequency is set higher than 706 kHz, during short-circuit condition the system finds a different equilibrium with higher current. For example, with $F_{SW}=800\text{ kHz}$ and the output shorted to ground, the output current is limited around:

Equation 5

$$I_{OUT} = \frac{V_{IN} \cdot F_{SW}^* - V_F / T_{ON_MIN}}{(DRC / T_{ON_MIN}) + (R_{DSON} + DCR) \cdot F_{SW}^*} = 4.2\text{A}$$

where F_{SW}^* is 800 kHz divided by eight.

Figure 7. Overcurrent protection

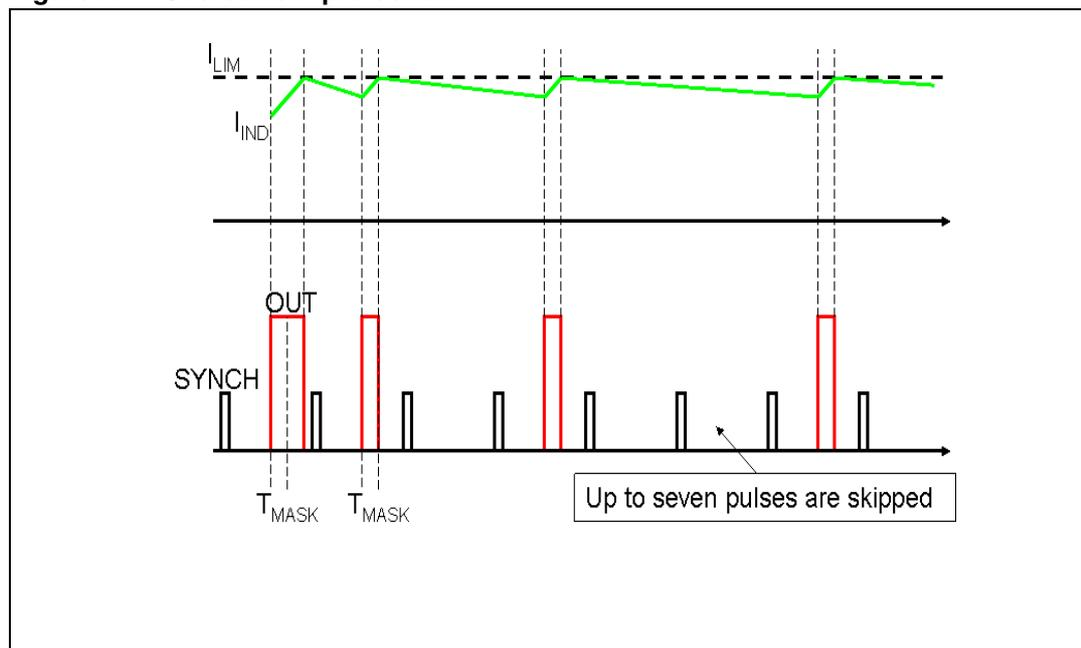

5.5 Enable function

The enable feature allows to put the device into standby mode. With the EN pin lower than 0.3 V the device is disabled and the power consumption is reduced to less than 30 μA . With the EN pin lower than 1.2 V, the device is enabled. If the EN pin is left floating, an internal pull-down ensures that the voltage at the pin reaches the inhibit threshold and the device is disabled. The pin is also V_{CC} compatible.

5.6 Hysteretic thermal shutdown

The thermal shutdown block generates a signal that turns off the power stage if the junction temperature goes above 150 $^{\circ}\text{C}$. Once the junction temperature returns to about 120 $^{\circ}\text{C}$, the device restarts in normal operation. The sensing element is very close to the PDMOS area, so ensuring an accurate and fast temperature detection.

6 Application information

6.1 Input capacitor selection

The capacitor connected to the input must be capable of supporting the maximum input operating voltage and the maximum RMS input current required by the device. The input capacitor is subject to a pulsed current, the RMS value of which is dissipated over its ESR, affecting the overall system efficiency.

So, the input capacitor must have an RMS current rating higher than the maximum RMS input current and an ESR value compliant with the expected efficiency.

The maximum RMS input current flowing through the capacitor can be calculated as:

Equation 6

$$I_{RMS} = I_O \cdot \sqrt{D - \frac{2 \cdot D^2}{\eta} + \frac{D^2}{\eta^2}}$$

where I_O is the maximum DC output current, D is the duty cycle, η is the efficiency. Considering $\eta=1$, this function has a maximum at $D=0.5$ and it is equal to $I_O/2$.

In a specific application, the range of possible duty cycles must be considered in order to find out the maximum RMS input current. The maximum and minimum duty cycles can be calculated as:

Equation 7

$$D_{MAX} = \frac{V_{OUT} + V_F}{V_{INMIN} - V_{SW}}$$

and

Equation 8

$$D_{MIN} = \frac{V_{OUT} + V_F}{V_{INMAX} - V_{SW}}$$

where V_F is the forward voltage on the freewheeling diode and V_{SW} is the voltage drop across the internal PDMOS.

The peak-to-peak voltage across the input capacitor can be calculated as:

Equation 9

$$V_{PP} = \frac{I_O}{C_{IN} \cdot F_{SW}} \cdot \left[\left(1 - \frac{D}{\eta}\right) \cdot D + \frac{D}{\eta} \cdot (1 - D) \right] + ESR \cdot I_O$$

where ESR is the equivalent series resistance of the capacitor.

Given the physical dimension, ceramic capacitors can well meet the requirements of the input filter sustaining a higher input RMS current than electrolytic/tantalum types. In this case the equation of C_{IN} as a function of the target V_{PP} can be written as follows:

Equation 10

$$C_{IN} = \frac{I_O}{V_{PP} \cdot F_{SW}} \cdot \left[\left(1 - \frac{D}{\eta}\right) \cdot D + \frac{D}{\eta} \cdot (1 - D) \right]$$

neglecting the small ESR of ceramic capacitors.

Considering $\eta=1$, this function has its maximum in $D=0.5$, therefore, given the maximum peak-to-peak input voltage (V_{PP_MAX}), the minimum input capacitor (C_{IN_MIN}) value is:

Equation 11

$$C_{IN_MIN} = \frac{I_O}{2 \cdot V_{PP_MAX} \cdot F_{SW}}$$

Typically C_{IN} is dimensioned to keep the maximum peak-to-peak voltage in the order of 1% of V_{INMAX}

In [Table 6](#) some multi-layer ceramic capacitors suitable for this device are reported.

Table 6. Input MLCC capacitors

Manufacture	Series	Cap value (μ F)	Rated voltage (V)
Taiyo Yuden	UMK325BJ106MM-T	10	50
	GMK325BJ106MN-T	10	35
Murata	GRM32ER71H475K	4.7	50

A ceramic bypass capacitor, as close to the VCC and GND pins as possible, so that additional parasitic ESR and ESL are minimized, is suggested in order to prevent instability on the output voltage due to noise. The value of the bypass capacitor can go from 100 nF to 1 μ F.

6.2 Inductor selection

The inductance value fixes the current ripple flowing through the output capacitor. So the minimum inductance value, in order to have the expected current ripple, must be selected. The rule to fix the current ripple value is to have a ripple at 20%-40% of the output current.

In the continuous current mode (CCM), the inductance value can be calculated by the following equation:

Equation 12

$$\Delta I_L = \frac{V_{IN} - V_{OUT}}{L} \cdot T_{ON} = \frac{V_{OUT} + V_F}{L} \cdot T_{OFF}$$

where T_{ON} is the conduction time of the internal high-side switch and T_{OFF} is the conduction time of the external diode (in CCM, $F_{SW}=1/(T_{ON} + T_{OFF})$). The maximum current ripple, at fixed V_{OUT} , is obtained at maximum T_{OFF} which is at minimum duty cycle (see [Section 6.1](#) to calculate minimum duty). So, by fixing $\Delta I_L=20\%$ to 30% of the maximum output current, the minimum inductance value can be calculated:

Equation 13

$$L_{MIN} = \frac{V_{OUT} + V_F}{\Delta I_{MAX}} \cdot \frac{1 - D_{MIN}}{F_{SW}}$$

where F_{SW} is the switching frequency, $1/(T_{ON} + T_{OFF})$.

For example, for $V_{OUT}=5$ V, $V_{IN}=24$ V, $I_O=3$ A and $F_{SW}=250$ kHz, the minimum inductance value to have $\Delta I_L=30\%$ of I_O is about 18 μ H.

The peak current through the inductor is given by:

Equation 14

$$I_{L, PK} = I_O + \frac{\Delta I_L}{2}$$

So, if the inductor value decreases, then the peak current (that must be lower than the minimum current limit of the device) increases. According to the maximum DC output current for this product family (3 A), the higher the inductor value, the higher the average output current that can be delivered, without triggering the overcurrent protection.

In [Table 7](#) some inductor part numbers are listed.

Table 7. Inductors

Manufacturer	Series	Inductor value (μ H)	Saturation current (A)
Coilcraft	MSS1038	3.8 to 10	3.9 to 6.5
	MSS1048	12 to 22	3.84 to 5.34
Würth	PD Type L	8.2 to 15	3.75 to 6.25
	PD Type M	2.2 to 4.7	4 to 6
SUMIDA	CDRH6D226/HP	1.5 to 3.3	3.6 to 5.2
	CDR10D48MN	6.6 to 12	4.1 to 5.7

6.3 Output capacitor selection

The current in the capacitor has a triangular waveform which generates a voltage ripple across it. This ripple is due to the capacitive component (charge or discharge of the output capacitor) and the resistive component (due to the voltage drop across its ESR). So the output capacitor must be selected in order to have a voltage ripple compliant with the application requirements.

The amount of the voltage ripple can be calculated starting from the current ripple obtained by the inductor selection.

Equation 15

$$\Delta V_{OUT} = ESR \cdot \Delta I_{MAX} + \frac{\Delta I_{MAX}}{8 \cdot C_{OUT} \cdot f_{SW}}$$

Usually the resistive component of the ripple is much higher than the capacitive one, if the output capacitor adopted is not a multi-layer ceramic capacitor (MLCC) with very low ESR value.

The output capacitor is important also for loop stability: it fixes the double LC filter pole and the zero due to its ESR. [Section 6.4](#) illustrates how to consider its effect in the system stability.

For example, with $V_{OUT}=5$ V, $V_{IN}=24$ V, $\Delta I_L=0.9$ A (resulting from the inductor value), in order to have a $\Delta V_{OUT}=0.01 \cdot V_{OUT}$, if the multi-layer ceramic capacitors are adopted, 10 μ F are needed and the ESR effect on the output voltage ripple can be neglected. In the case of non-negligible ESR (electrolytic or tantalum capacitors), the capacitor is chosen taking into account its ESR value. So, in case of 330 μ F with ESR=30 m Ω , the resistive component of the drop dominates and the voltage ripple is 28 mV.

The output capacitor is also important to sustain the output voltage when a load transient with high slew rate is required by the load. When the load transient slew rate exceeds the system bandwidth, the output capacitor provides the current to the load. So, if the high slew rate load transient is required by the application, the output capacitor and system bandwidth must be chosen in order to sustain the load transient.

In [Table 8](#) some capacitor series are listed.

Table 8. Output capacitors

Manufacturer	Series	Cap value (μ F)	Rated voltage (V)	ESR (m Ω)
MURATA	GRM32	22 to 100	6.3 to 25	< 5
	GRM31	10 to 47	6.3 to 25	< 5
PANASONIC	ECJ	10 to 22	6.3	< 5
	EEFCD	10 to 68	6.3	15 to 55
SANYO	TPA/B/C	100 to 470	4 to 16	40 to 80
TDK	C3225	22 to 100	6.3	< 5

6.4 Compensation network

The compensation network must assure stability and good dynamic performance. The loop of the L7986TA is based on the voltage mode control. The error amplifier is a voltage operational amplifier with high bandwidth. So, by selecting the compensation network the E/A is considered as ideal, that is, its bandwidth is much larger than the system one.

The transfer functions of the PWM modulator and the output LC filter are studied (see [Figure 9](#)). The transfer function of the PWM modulator, from the error amplifier output (COMP pin) to the OUT pin, results:

Equation 16

$$G_{PW0} = \frac{V_{IN}}{V_S}$$

where V_S is the sawtooth amplitude. As seen in [Section 5.1](#), the voltage feed-forward generates a sawtooth amplitude directly proportional to the input voltage, that is:

Equation 17

$$V_S = K \cdot V_{IN}$$

In this way the PWM modulator gain results constant and equal to:

Equation 18

$$G_{PW0} = \frac{V_{IN}}{V_S} = \frac{1}{K} = 18$$

The synchronization of the device with an external clock provided through the SYNCH pin can modify the PWM modulator gain (see [Section 5.1](#) to understand how this gain changes and how to keep it constant in spite of the external synchronization).

Figure 8. The error amplifier, the PWM modulator, and the LC output filter

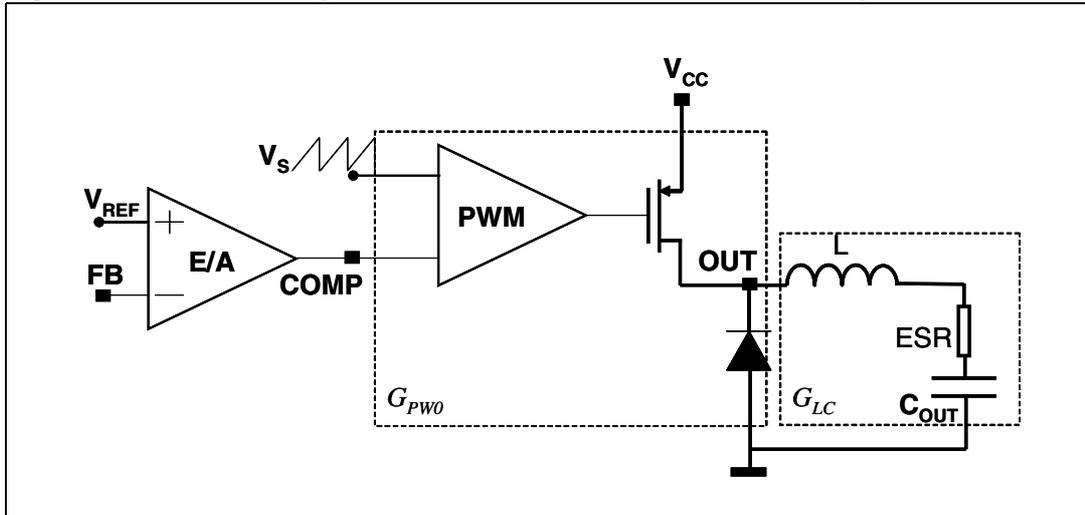

The transfer function on the LC filter is given by:

Equation 19

$$G_{LC}(s) = \frac{1 + \frac{s}{2\pi \cdot f_{zESR}}}{1 + \frac{s}{2\pi \cdot Q \cdot f_{LC}} + \left(\frac{s}{2\pi \cdot f_{LC}}\right)^2}$$

where:

Equation 20

$$f_{LC} = \frac{1}{2\pi \cdot \sqrt{L \cdot C_{OUT}} \cdot \sqrt{1 + \frac{ESR}{R_{OUT}}}}, \quad f_{zESR} = \frac{1}{2\pi \cdot ESR \cdot C_{OUT}}$$

Equation 21

$$Q = \frac{\sqrt{R_{OUT} \cdot L \cdot C_{OUT} \cdot (R_{OUT} + ESR)}}{L + C_{OUT} \cdot R_{OUT} \cdot ESR}, \quad R_{OUT} = \frac{V_{OUT}}{I_{OUT}}$$

As seen in [Section 5.3](#), two different kinds of network can compensate the loop. In the following two paragraphs the guidelines to select the type II and type III compensation network are illustrated.

6.4.1 Type III compensation network

The methodology to stabilize the loop consists of placing two zeroes to compensate the effect of the LC double pole, therefore increasing phase margin; then, to place one pole in the origin to minimize the dc error on regulated output voltage; and finally, to place other poles far from the zero dB frequency.

If the equivalent series resistance (ESR) of the output capacitor introduces a zero with a frequency higher than the desired bandwidth (that is: $2\pi \cdot ESR \cdot C_{OUT} < 1/BW$), the type III compensation network is needed. Multi-layer ceramic capacitors (MLCC) have very low ESR (<1 mΩ), with very high frequency zero, so a type III network is adopted to compensate the loop.

In [Figure 9](#) the type III compensation network is shown. This network introduces two zeroes (f_{Z1} , f_{Z2}) and three poles (f_{P0} , f_{P1} , f_{P2}). They are expressed as:

Equation 22

$$f_{Z1} = \frac{1}{2\pi \cdot C_3 \cdot (R_1 + R_3)}, \quad f_{Z2} = \frac{1}{2\pi \cdot R_4 \cdot C_4}$$

Equation 23

$$f_{P0} = 0, \quad f_{P1} = \frac{1}{2\pi \cdot R_3 \cdot C_3}, \quad f_{P2} = \frac{1}{2\pi \cdot R_4 \cdot \frac{C_4 \cdot C_5}{C_4 + C_5}}$$

Figure 9. Type III compensation network

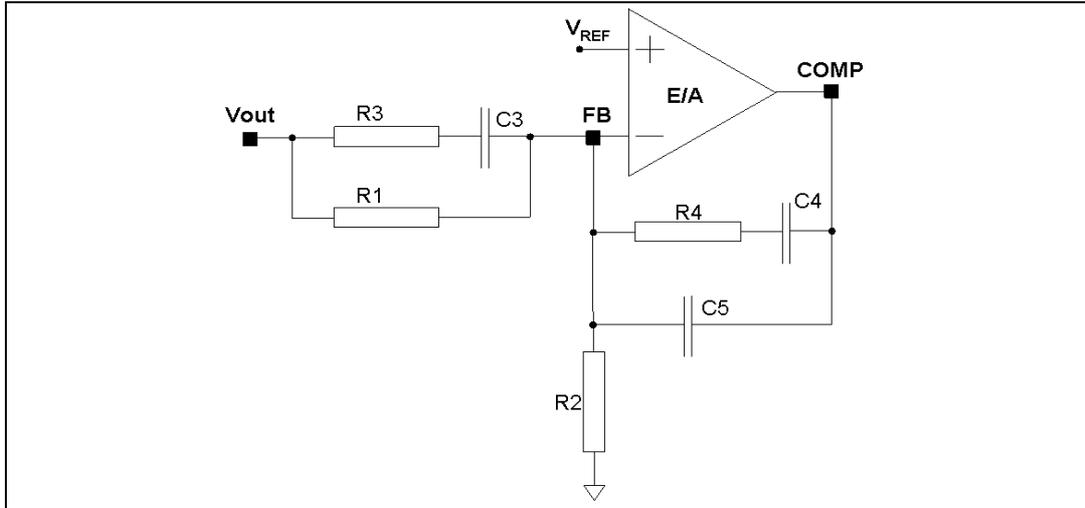

In [Figure 10](#) the Bode diagram of the PWM and LC filter transfer function ($G_{PWM} \cdot G_{LC}(f)$) and the open-loop gain ($G_{LOOP}(f) = G_{PWM} \cdot G_{LC}(f) \cdot G_{TYPEIII}(f)$) are drawn.

Figure 10. Open-loop gain: module Bode diagram

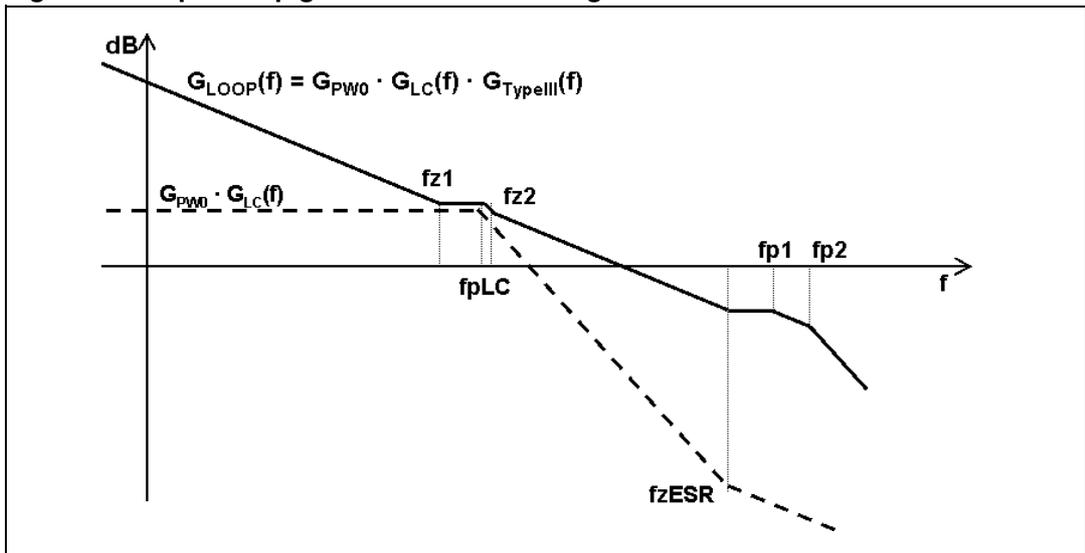

The guidelines for positioning the poles and the zeroes and for calculating the component values can be summarized as follows:

1. Choose a value for R_1 , usually between 1 k Ω and 5 k Ω
2. Choose a gain (R_4/R_1) in order to have the required bandwidth (BW), that means:

Equation 24

$$R_4 = \frac{BW}{f_{LC}} \cdot K \cdot R_1$$

where K is the feed-forward constant and 1/K is equal to 18.

3. Calculate C_4 by placing the zero at 50% of the output filter double pole frequency (f_{LC}):

Equation 25

$$C_4 = \frac{1}{\pi \cdot R_4 \cdot f_{LC}}$$

4. Calculate C_5 by placing the second pole at four times the system bandwidth (BW):

Equation 26

$$C_5 = \frac{C_4}{2\pi \cdot R_4 \cdot C_4 \cdot 4 \cdot BW - 1}$$

5. Set also the first pole at four times the system bandwidth and also the second zero at the output filter double pole:

Equation 27

$$R_3 = \frac{R_1}{\frac{4 \cdot BW}{f_{LC}} - 1}, \quad C_3 = \frac{1}{2\pi \cdot R_3 \cdot 4 \cdot BW}$$

The suggested maximum system bandwidth is equal to the switching frequency divided by 3.5 ($F_{SW}/3.5$), anyway, lower than 100 kHz if the F_{SW} is set higher than 500 kHz.

For example, with $V_{OUT}=5$ V, $V_{IN}=24$ V, $I_O=3$ A, $L=18$ μ H, $C_{OUT}=22$ μ F, and $ESR<1$ m Ω the type III compensation network is:

Equation 28

$$R_1 = 4.99\text{k}\Omega \quad R_2 = 680\Omega \quad R_3 = 200\Omega \quad R_4 = 2\text{k}\Omega \quad C_3 = 3.3\text{nF}, \quad C_4 = 22\text{nF}, \quad C_5 = 220\text{pF}$$

In [Figure 11](#) the module and phase of the open-loop gain is shown. The bandwidth is about 58 kHz and the phase margin is 50 °.

Figure 11. Open-loop gain Bode diagram with ceramic output capacitor

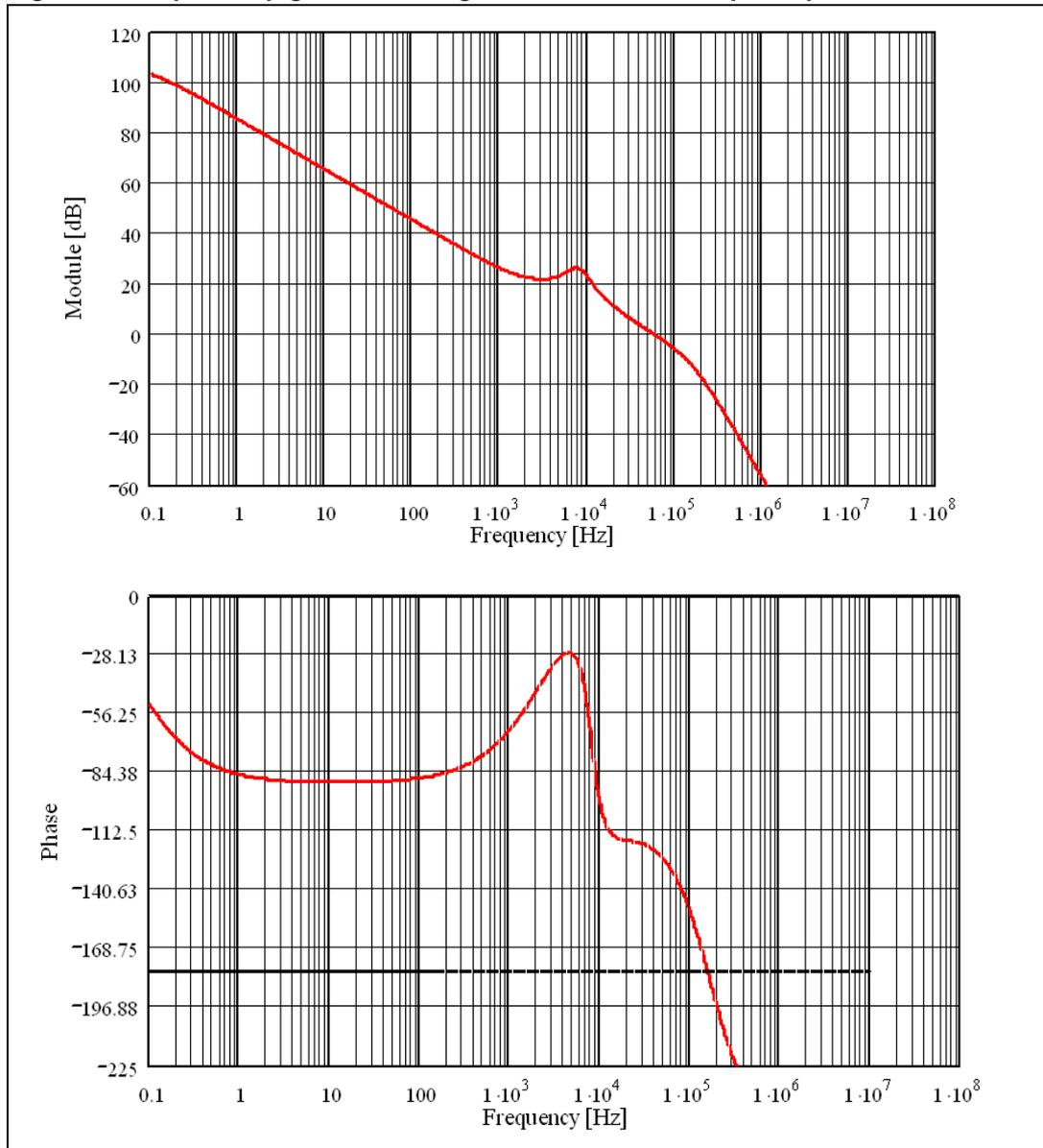

6.4.2 Type II compensation network

If the equivalent series resistance (ESR) of the output capacitor introduces a zero with a frequency lower than the desired bandwidth (that is: $2\pi \cdot \text{ESR} \cdot C_{\text{OUT}} > 1/\text{BW}$), this zero helps stabilize the loop. Electrolytic capacitors show non-negligible ESR ($>30 \text{ m}\Omega$), so with this kind of output capacitor the type II network combined with the zero of the ESR allows to stabilize the loop.

In [Figure 12](#) the type II network is shown.

Figure 12. Type II compensation network

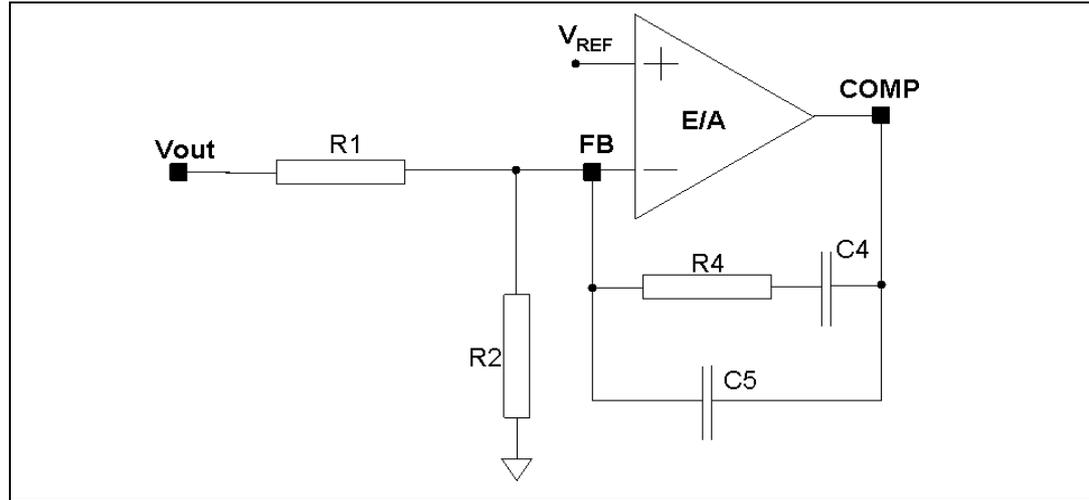

The singularities of the network are:

Equation 29

$$f_{Z1} = \frac{1}{2\pi \cdot R_4 \cdot C_4}, \quad f_{P0} = 0, \quad f_{P1} = \frac{1}{2\pi \cdot R_4 \cdot \frac{C_4 \cdot C_5}{C_4 + C_5}}$$

In [Figure 13](#) the Bode diagram of the PWM and LC filter transfer function ($G_{\text{PW0}} \cdot G_{\text{LC}}(f)$) and the open-loop gain ($G_{\text{LOOP}}(f) = G_{\text{PW0}} \cdot G_{\text{LC}}(f) \cdot G_{\text{TYPEII}}(f)$) are drawn.

Figure 13. Open-loop gain: module Bode diagram

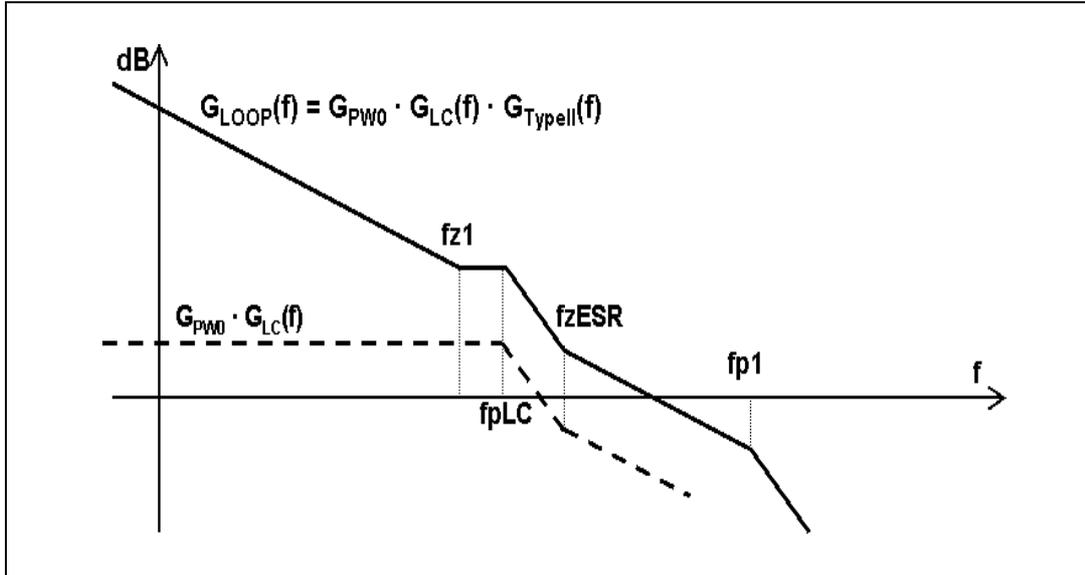

The guidelines for positioning the poles and the zeroes and for calculating the component values can be summarized as follows:

1. Choose a value for R_1 , usually between 1 k Ω and 5 k Ω in order to have values of C_4 and C_5 not comparable with parasitic capacitance of the board.
2. Choose a gain (R_4/R_1) in order to have the required bandwidth (BW), that means:

Equation 30

$$R_4 = \left(\frac{f_{\text{ESR}}}{f_{\text{LC}}} \right)^2 \cdot \frac{\text{BW}}{f_{\text{ESR}}} \cdot \frac{V_S}{V_{\text{IN}}} \cdot R_1$$

where f_{ESR} is the ESR zero:

Equation 31

$$f_{\text{ESR}} = \frac{1}{2\pi \cdot \text{ESR} \cdot C_{\text{OUT}}}$$

and V_S is the sawtooth amplitude. The voltage feed-forward keeps the ratio V_S/V_{IN} constant.

3. Calculate C_4 by placing the zero one decade below the output filter double pole:

Equation 32

$$C_4 = \frac{10}{2\pi \cdot R_4 \cdot f_{\text{LC}}}$$

4. Then calculate C_3 in order to place the second pole at four times the system bandwidth (BW):

Equation 33

$$C_5 = \frac{C_4}{2\pi \cdot R_4 \cdot C_4 \cdot 4 \cdot BW - 1}$$

For example, with $V_{OUT}=5$ V, $V_{IN}=24$ V, $I_O=3$ A, $L=18$ μ H, $C_{OUT}=330$ μ F, and $ESR=35$ m Ω , the type II compensation network is:

Equation 34

$$R_1 = 1.1\text{k}\Omega \quad R_2 = 150\Omega \quad R_4 = 4.99\text{k}\Omega \quad C_4 = 82\text{nF} \quad C_5 = 68\text{pF}$$

In [Figure 14](#) the module and phase of the open-loop gain is shown. The bandwidth is about 21 kHz and the phase margin is 45 °.

Figure 14. Open-loop gain Bode diagram with electrolytic/tantalum output capacitor

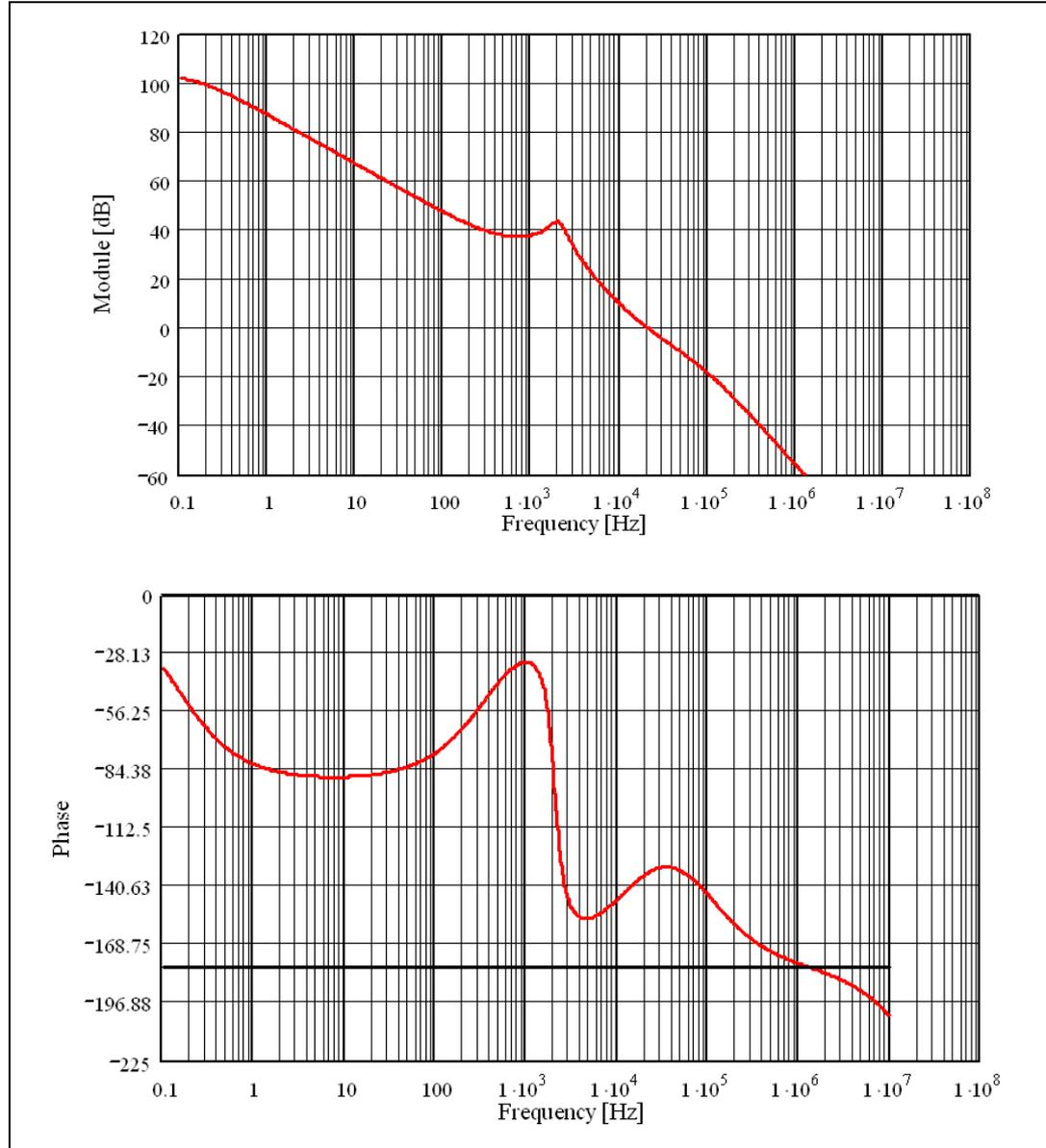

6.5 Thermal considerations

The thermal design is important to prevent the thermal shutdown of the device if junction temperature goes above 150 °C. The three different sources of losses within the device are:

- a) conduction losses due to the non-negligible R_{DSon} of the power switch; these are equal to:

Equation 35

$$P_{ON} = R_{DSon} \cdot (I_{OUT})^2 \cdot D$$

where D is the duty cycle of the application and the maximum $R_{DS(on)}$ overtemperature is 220 mΩ. Note that the duty cycle is theoretically given by the ratio between V_{OUT} and V_{IN} , but actually it is quite higher in order to compensate the losses of the regulator. So the conduction losses increase compared with the ideal case.

- b) switching losses due to power MOSFET turn-on and turn-off; these can be calculated as:

Equation 36

$$P_{SW} = V_{IN} \cdot I_{OUT} \cdot \frac{(T_{RISE} + T_{FALL})}{2} \cdot F_{SW} = V_{IN} \cdot I_{OUT} \cdot T_{SW} \cdot F_{SW}$$

where T_{RISE} and T_{FALL} are the overlap times of the voltage across the power switch (V_{DS}) and the current flowing into it during turn-on and turn-off phases, as shown in [Figure 15](#). T_{SW} is the equivalent switching time. For this device the typical value for the equivalent switching time is 40 ns.

- c) quiescent current losses, calculated as:

Equation 37

$$P_Q = V_{IN} \cdot I_Q$$

where I_Q is the quiescent current ($I_Q=2.4$ mA).

The junction temperature T_J can be calculated as:

Equation 38

$$T_J = T_A + R_{thJA} \cdot P_{TOT}$$

where T_A is the ambient temperature and P_{TOT} is the sum of the power losses just seen.

R_{thJA} is the equivalent thermal resistance junction to ambient of the device; it can be calculated as the parallel of many paths of heat conduction from the junction to the ambient. For this device the path through the exposed pad is the one conducting the largest amount of heat. The R_{thJA} measured on the demonstration board described in the following paragraph is about 40 °C/W for the HSOP package.

Figure 15. Switching losses

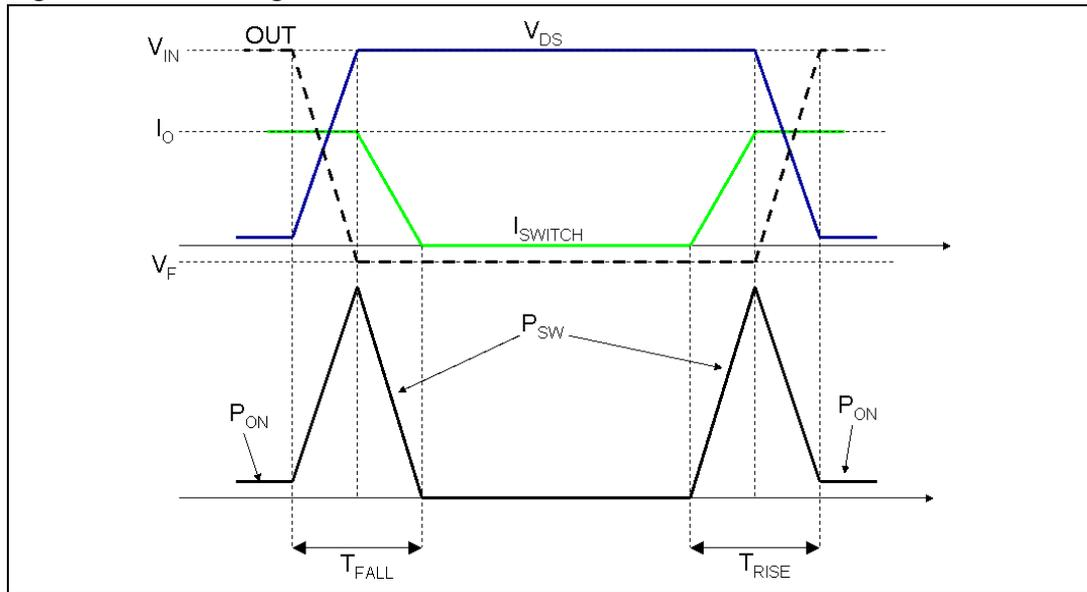

6.6 Layout considerations

The PC board layout of the switching DC/DC regulator is very important to minimize the noise injected in high impedance nodes and interference generated by the high switching current loops.

In a step-down converter the input loop (including the input capacitor, the power MOSFET and the freewheeling diode) is the most critical one. This is due to the fact that the high value pulsed currents are flowing through it. In order to minimize the EMI, this loop must be as short as possible.

The feedback pin (FB) connection to the external resistor divider is a high impedance node, so the interferences can be minimized by placing the routing of the feedback node as far as possible from the high current paths. To reduce the pick-up noise, the resistor divider must be placed very close to the device.

To filter the high frequency noise, a small bypass capacitor (220 nF - 1 μ F) can be added as close as possible to the input voltage pin of the device.

Thanks to the exposed pad of the device, the ground plane helps to reduce the thermal resistance junction to ambient; so a large ground plane enhances the thermal performance of the converter allowing high power conversion.

In [Figure 16](#) a layout example is shown.

Figure 16. Layout example

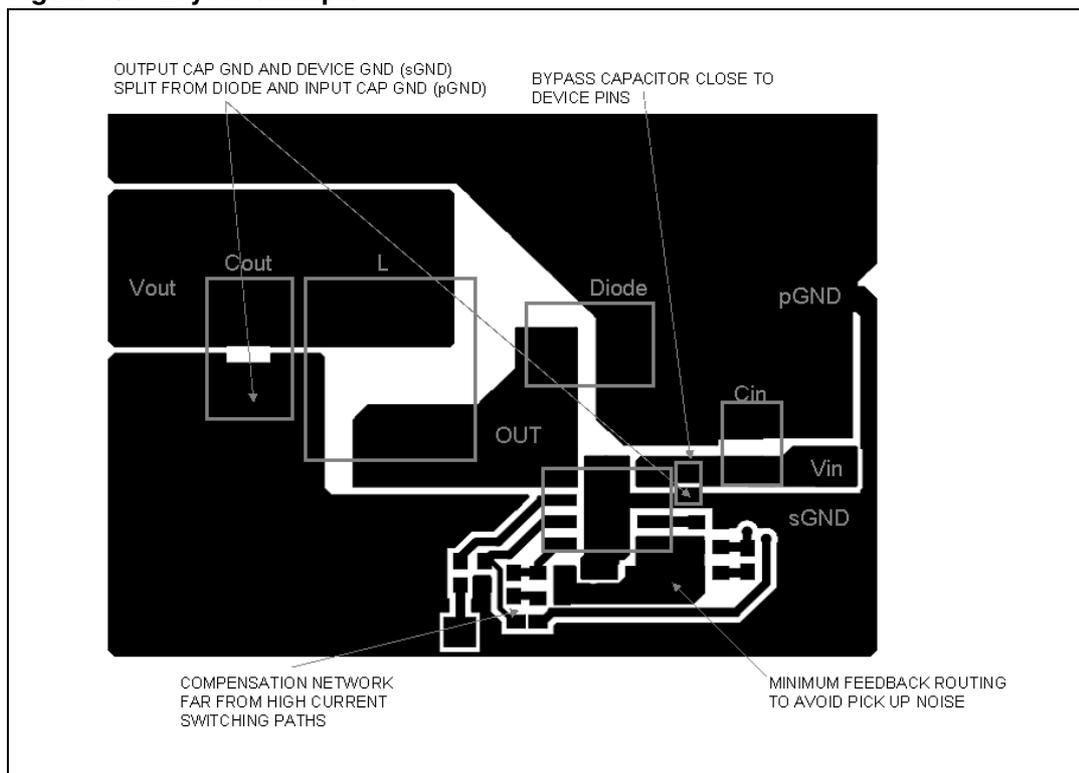

Figure 18. PCB layout: L7986TA (component side)

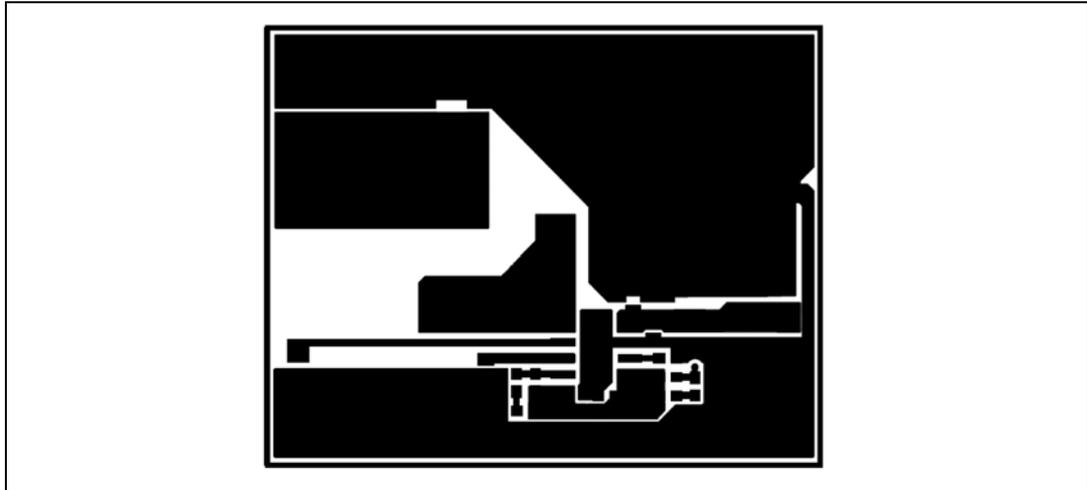

Figure 19. PCB layout: L7986TA (bottom side)

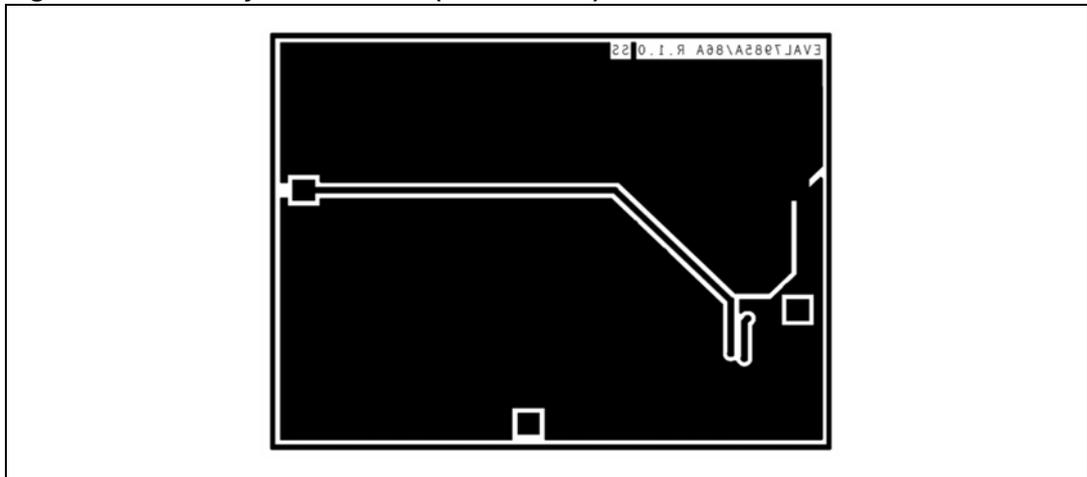

Figure 20. PCB layout: L7986TA (front side)

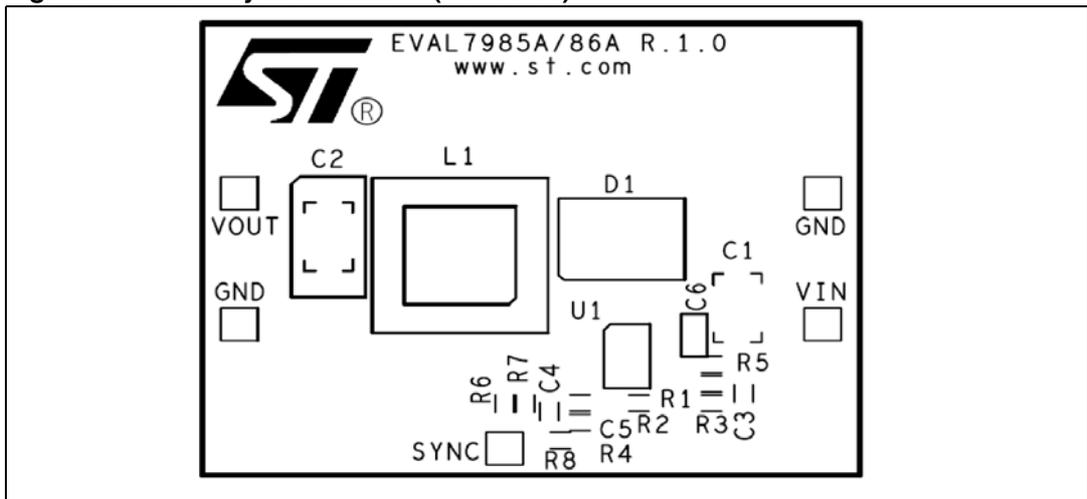

Figure 21. Junction temperature vs. output current

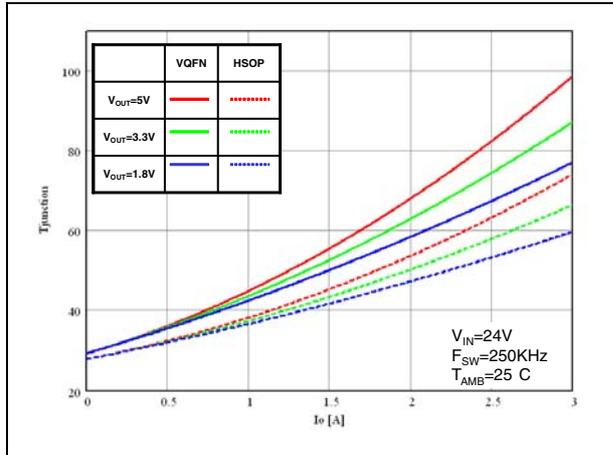

Figure 22. Junction temperature vs. output current

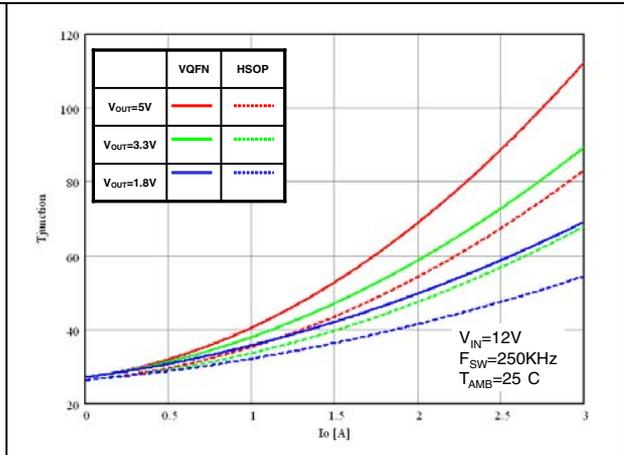

Figure 23. Junction temperature vs. output current

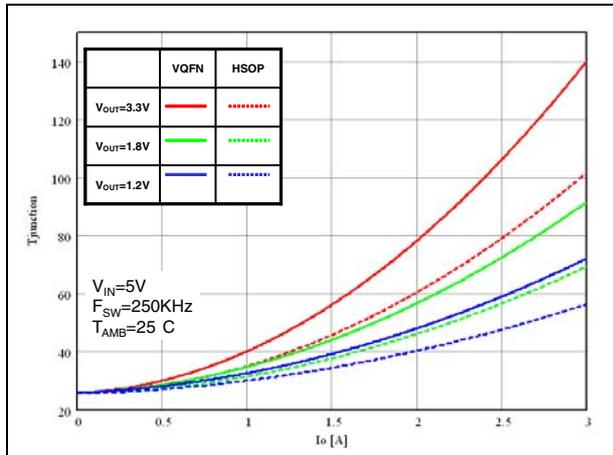

Figure 24. Efficiency vs. output current

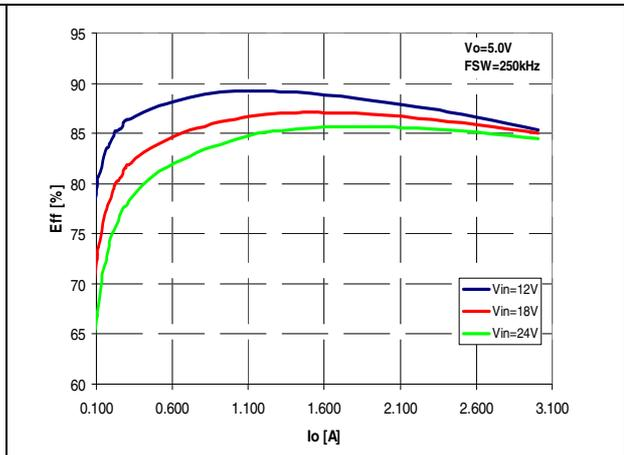

Figure 25. Efficiency vs. output current

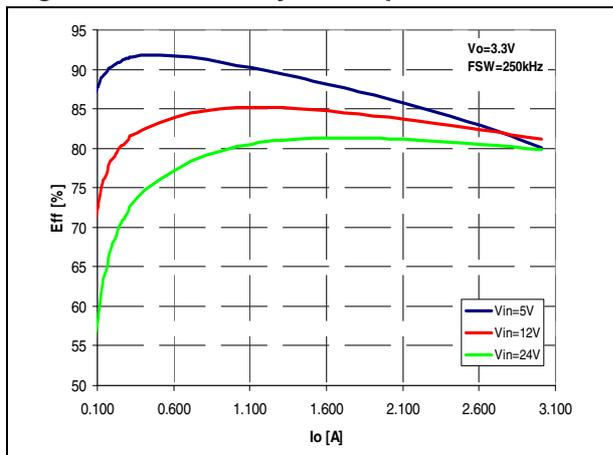

Figure 26. Efficiency vs. output current

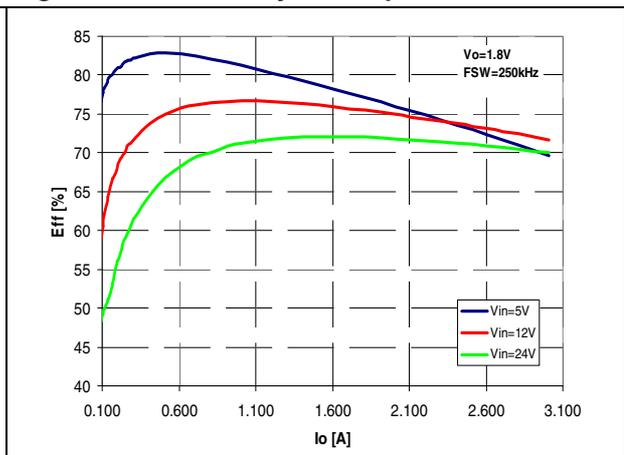

Figure 27. Load regulation

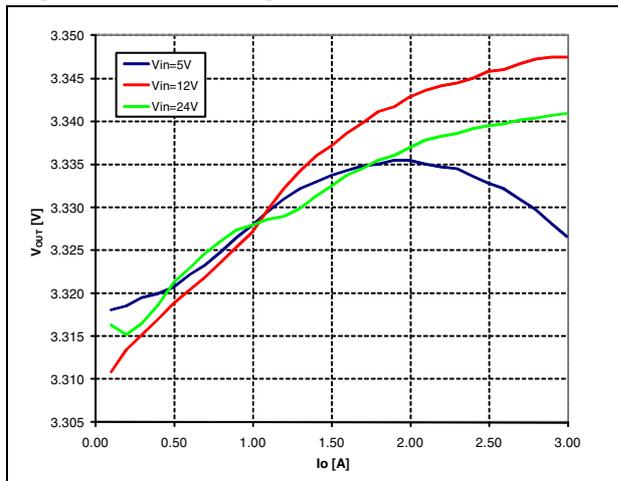

Figure 28. Line regulation

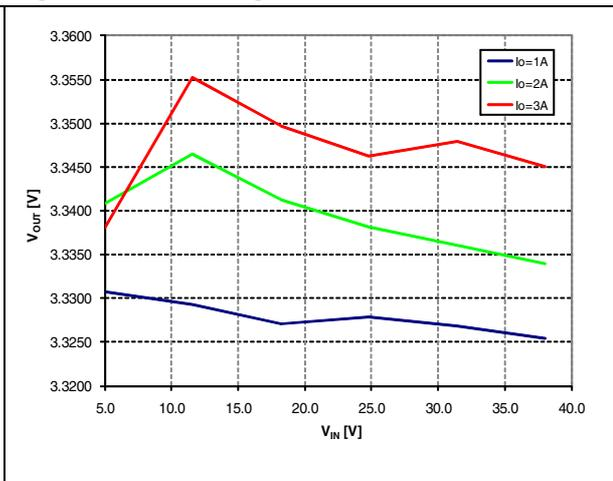

Figure 29. Load transient: from 0.4 A to 3 A

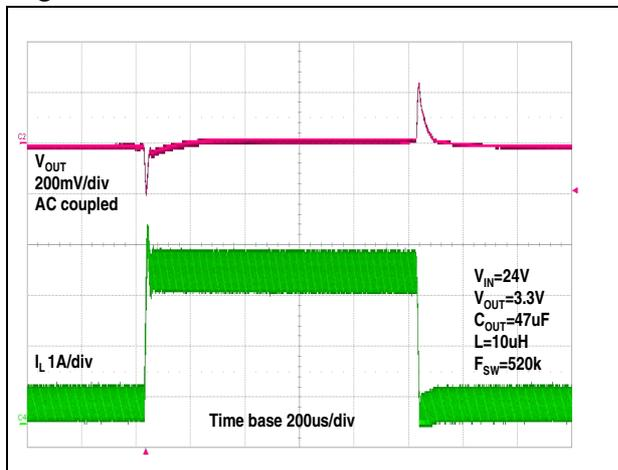

Figure 30. Soft-start

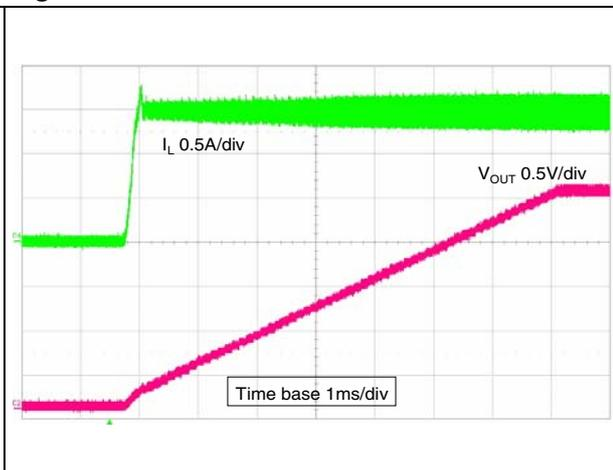

Figure 31. Short-circuit behavior $V_{IN}=12V$

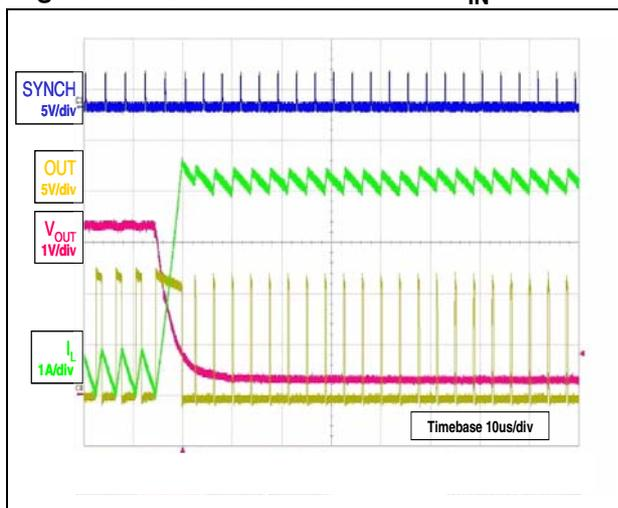
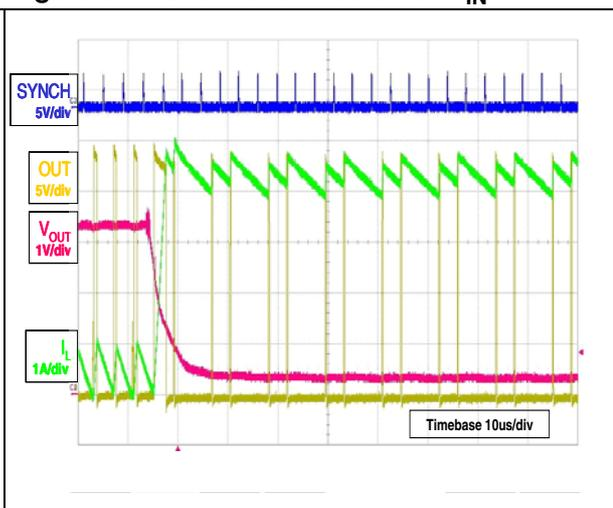

Figure 32. Short-circuit behavior $V_{IN}=24V$



7 Application ideas

7.1 Positive buck-boost

The L7986TA can implement the step-up/down converter with a positive output voltage.

Figure 33. shows the schematic: one power MOSFET and one Schottky diode are added to the standard buck topology to provide 12 V output voltage with input voltage from 4.5 V to 38 V.

Figure 33. Positive buck-boost regulator

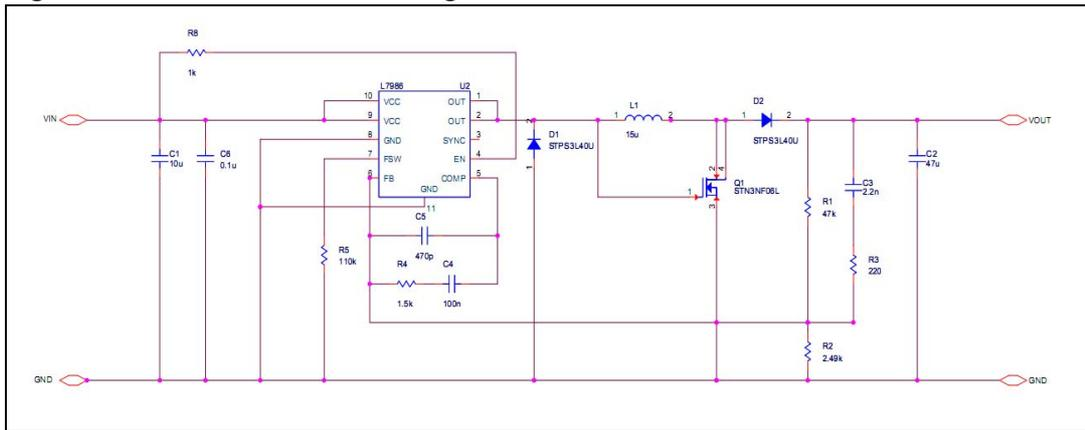

The relationship between input and output voltage is:

Equation 39

$$V_{OUT} = V_{IN} \cdot \frac{D}{1-D}$$

so the duty cycle is:

Equation 40

$$D = \frac{V_{OUT}}{V_{OUT} + V_{IN}}$$

The output voltage isn't limited by the maximum operating voltage of the device (38 V), because the output voltage is sensed only through the resistor divider. The external power MOSFET maximum drain to source voltage must be higher than the output voltage; the maximum gate to source voltage must be higher than the input voltage (in *Figure 33*, if V_{IN} is higher than 16 V, the gate must be protected through a Zener diode and resistor)

The current flowing through the internal power MOSFET is transferred to the load only during the off-time, so according to the maximum DC switch current (3.0 A), the maximum output current for the buck-boost topology can be calculated from the following equation.

Equation 41

$$I_{SW} = \frac{I_{OUT}}{1-D} < 3 \text{ A}$$

where I_{SW} is the average current in the embedded power MOSFET in the on-time.

To choose the right value of the inductor and to manage transient output current, which for a short time can exceed the maximum output current calculated by [Equation 41](#), also the peak current in the power MOSFET must be calculated. The peak current, shown in [Equation 42](#), must be lower than the minimum current limit (3.7 A).

Equation 42

$$I_{SW,PK} = \frac{I_{OUT}}{1-D} \cdot \left[1 + \frac{r}{2} \right] < 3.7 \text{ A}$$

$$r = \frac{V_{OUT}}{I_{OUT} \cdot L \cdot F_{SW}} \cdot (1-D)^2$$

where r is defined as the ratio between the inductor current ripple and the inductor DC current:

So, in the buck-boost topology the maximum output current depends on the application conditions (firstly input and output voltage, secondly switching frequency and inductor value).

In [Figure 34](#) the maximum output current for the above configuration is depicted varying the input voltage from 4.5 V to 38 V.

The dashed line considers a more accurate estimation of the duty cycles given by [Equation 43](#), where power losses across diodes, external power MOSFET, and internal power MOSFET are taken into account.

Figure 34. Maximum output current according to max. DC switch current (3.0 A): $V_O=12 \text{ V}$

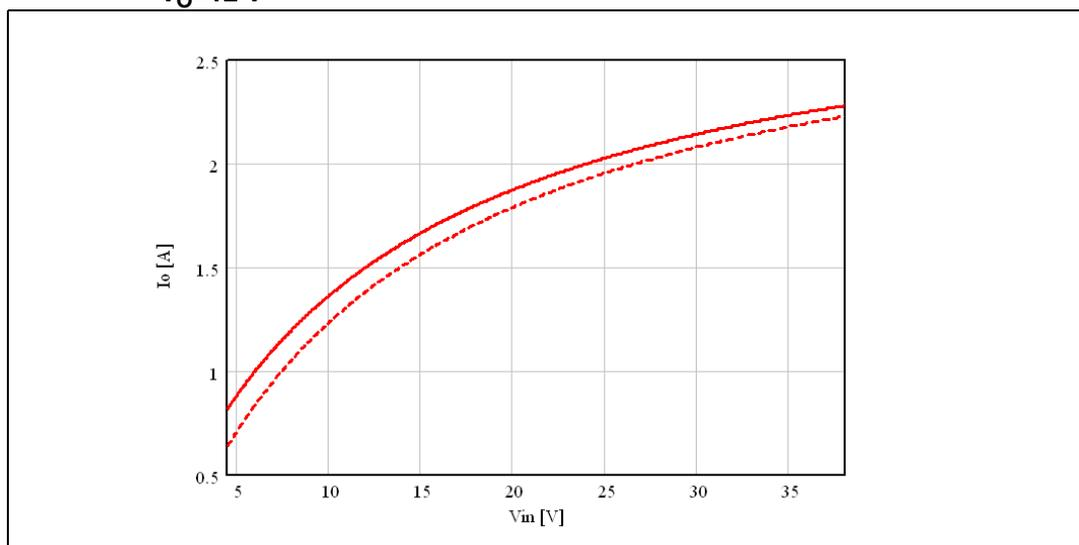

The GND pin of the device is connected to the output voltage so, given the output voltage, input voltage range is limited by the maximum voltage the device can withstand across VCC and GND (38 V). Therefore, if the output is -5 V the input voltage can range from 4.5 V to 33 V.

As in the positive buck-boost, the maximum output current according to application conditions is shown in [Figure 36](#). The dashed line considers a more accurate estimation of the duty cycles given by [Equation 46](#), where power losses across diodes and the internal power MOSFET are taken into account.

Equation 46

$$D = \frac{V_{OUT} - V_D}{-V_{IN} - V_{SW} + V_{OUT} - V_D}$$

**Figure 36. Maximum output current according to switch max. peak current (3.0 A):
V_O=-5 V**

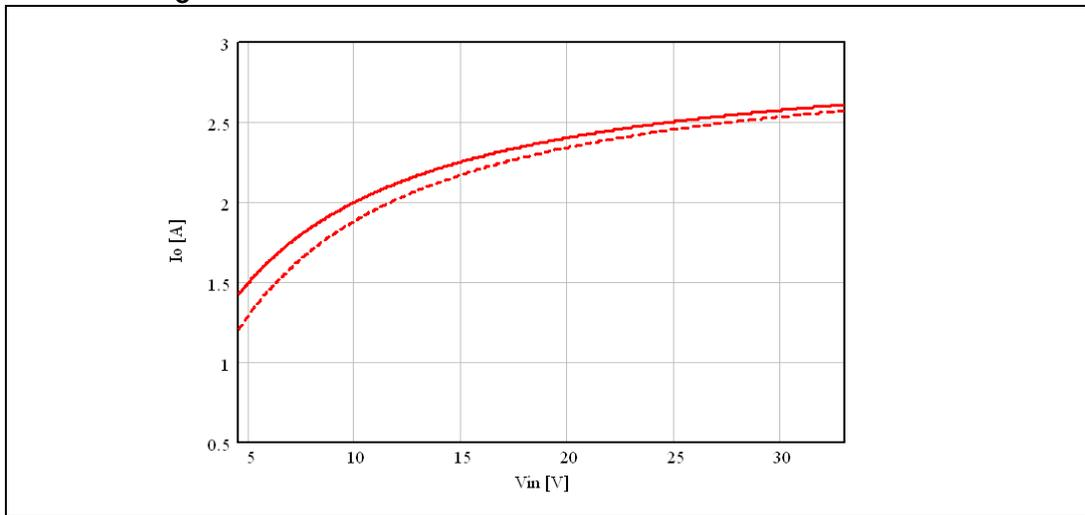

8 Package mechanical data

In order to meet environmental requirements, ST offers these devices in different grades of ECOPACK[®] packages, depending on their level of environmental compliance. ECOPACK[®] specifications, grade definitions and product status are available at: www.st.com. ECOPACK[®] is an ST trademark.

Table 10. HSOP8 mechanical data

Dim	mm		
	Min.	Typ.	Max.
A			1.70
A1	0.00		0.150
A2	1.25		
b	0.31		0.51
c	0.17		0.25
D	4.80	4.90	5.00
E	5.80	6.00	6.20
E1	3.80	3.90	4.00
e		1.27	
h	0.25		0.50
L	0.40		1.27
k	0.00		8.00
ccc			0.10

Figure 37. Package dimensions

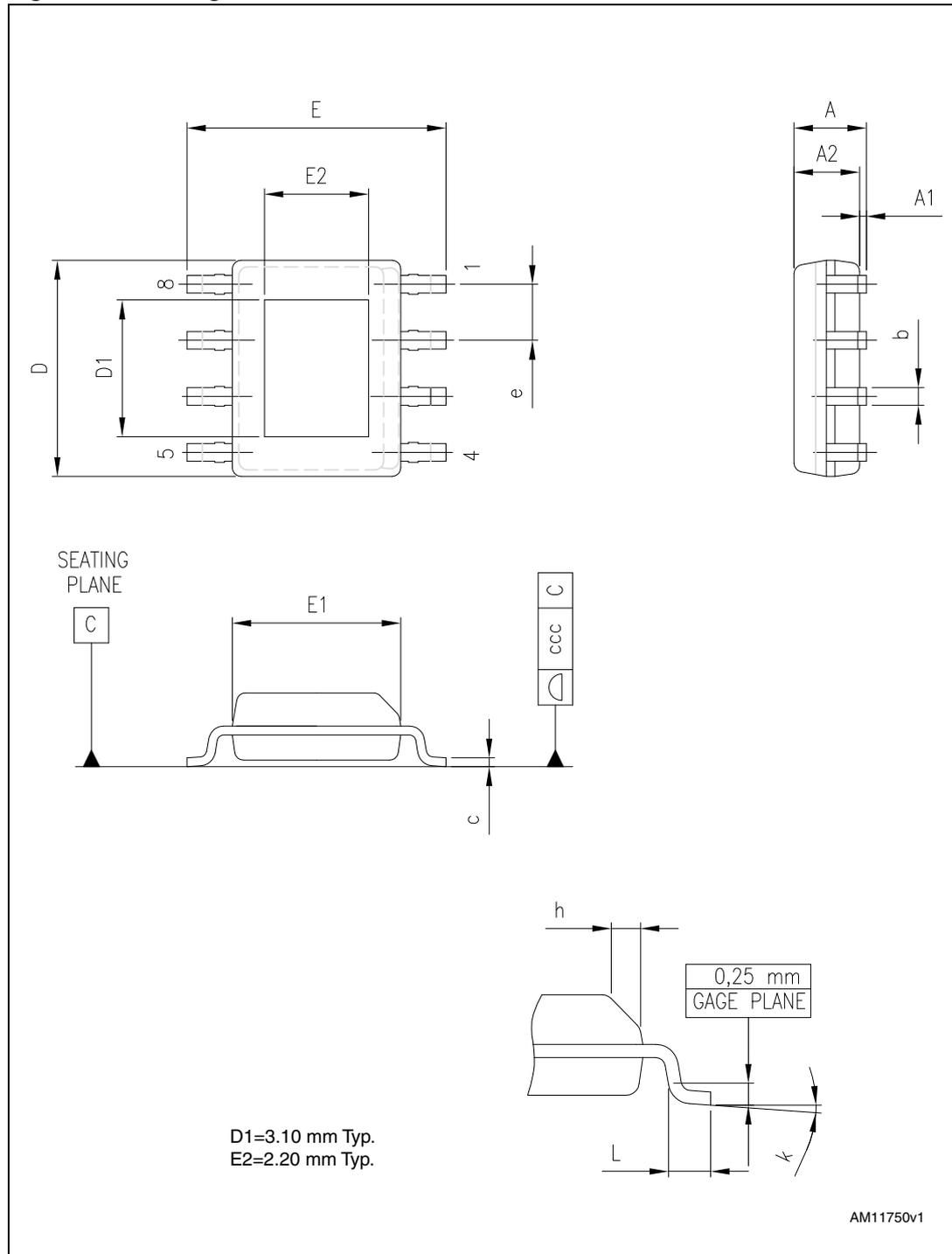

9 Ordering information

Table 11. Order code

Order code	Package	Packaging
L7986TA	HSOP8	Tube
L7986TATR	HSOP8	Tape and reel

10 Revision history

Table 12. Document revision history

Date	Revision	Changes
25-Oct-2011	1	Initial release.
01-Mar-2012	2	<i>Section 8: Package mechanical data</i> has been updated.
16-Oct-2012	3	In <i>Section 5.6</i> changed temperature value from 130 to 120 °C

Please Read Carefully:

Information in this document is provided solely in connection with ST products. STMicroelectronics NV and its subsidiaries ("ST") reserve the right to make changes, corrections, modifications or improvements, to this document, and the products and services described herein at any time, without notice.

All ST products are sold pursuant to ST's terms and conditions of sale.

Purchasers are solely responsible for the choice, selection and use of the ST products and services described herein, and ST assumes no liability whatsoever relating to the choice, selection or use of the ST products and services described herein.

No license, express or implied, by estoppel or otherwise, to any intellectual property rights is granted under this document. If any part of this document refers to any third party products or services it shall not be deemed a license grant by ST for the use of such third party products or services, or any intellectual property contained therein or considered as a warranty covering the use in any manner whatsoever of such third party products or services or any intellectual property contained therein.

UNLESS OTHERWISE SET FORTH IN ST'S TERMS AND CONDITIONS OF SALE ST DISCLAIMS ANY EXPRESS OR IMPLIED WARRANTY WITH RESPECT TO THE USE AND/OR SALE OF ST PRODUCTS INCLUDING WITHOUT LIMITATION IMPLIED WARRANTIES OF MERCHANTABILITY, FITNESS FOR A PARTICULAR PURPOSE (AND THEIR EQUIVALENTS UNDER THE LAWS OF ANY JURISDICTION), OR INFRINGEMENT OF ANY PATENT, COPYRIGHT OR OTHER INTELLECTUAL PROPERTY RIGHT.

UNLESS EXPRESSLY APPROVED IN WRITING BY TWO AUTHORIZED ST REPRESENTATIVES, ST PRODUCTS ARE NOT RECOMMENDED, AUTHORIZED OR WARRANTED FOR USE IN MILITARY, AIR CRAFT, SPACE, LIFE SAVING, OR LIFE SUSTAINING APPLICATIONS, NOR IN PRODUCTS OR SYSTEMS WHERE FAILURE OR MALFUNCTION MAY RESULT IN PERSONAL INJURY, DEATH, OR SEVERE PROPERTY OR ENVIRONMENTAL DAMAGE. ST PRODUCTS WHICH ARE NOT SPECIFIED AS "AUTOMOTIVE GRADE" MAY ONLY BE USED IN AUTOMOTIVE APPLICATIONS AT USER'S OWN RISK.

Resale of ST products with provisions different from the statements and/or technical features set forth in this document shall immediately void any warranty granted by ST for the ST product or service described herein and shall not create or extend in any manner whatsoever, any liability of ST.

ST and the ST logo are trademarks or registered trademarks of ST in various countries.

Information in this document supersedes and replaces all information previously supplied.

The ST logo is a registered trademark of STMicroelectronics. All other names are the property of their respective owners.

© 2012 STMicroelectronics - All rights reserved

STMicroelectronics group of companies

Australia - Belgium - Brazil - Canada - China - Czech Republic - Finland - France - Germany - Hong Kong - India - Israel - Italy - Japan - Malaysia - Malta - Morocco - Philippines - Singapore - Spain - Sweden - Switzerland - United Kingdom - United States of America

www.st.com