

Dual Full-Bridge PWM Motor Driver

Features and Benefits

- Interchangeable with SGS L6219DS
- 750 mA Continuous Output Current
- 45 V Output Sustaining Voltage
- Internal Clamp Diodes
- Internal PWM Current Control
- Low Output Saturation Voltage
- Internal Thermal Shutdown Circuitry
- Similar to Dual PBL3717, UC3770

Package: 24 pin SOICW (suffix LB)

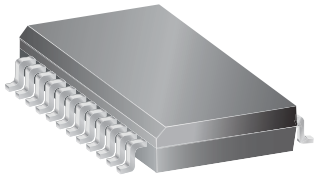

Not to scale

Description

The L6219DS motor driver is designed to drive both windings of a bipolar stepper motor or bidirectionally control two DC motors. Both bridges are capable of sustaining 45 V and include internal pulse-width modulation (PWM) control of the output current to 750 mA. The outputs have been optimized for a low output saturation voltage drop (less than 1.8 V total source plus sink at 500 mA).

For PWM current control, the maximum output current is determined by user selection of a reference voltage and sensing resistor. Two logic-level inputs select output current limits of 0, 33, 67, or 100% of the maximum level. A PHASE input to each bridge determines load current direction.

The bridges include both ground clamp and flyback diodes for protection against inductive transients. Internally generated delays prevent crossover currents when switching current direction. Special power-up sequencing is not required. Thermal protection circuitry disables the outputs if the chip temperature exceeds safe operating limits.

The L6219DS is supplied in a 24-pin surface-mountable SOIC, with 4 internally-fused leads for maximum package power dissipation in the smallest possible construction. It is lead (Pb) free with 100% matte tin leadframe plating.

Typical Application

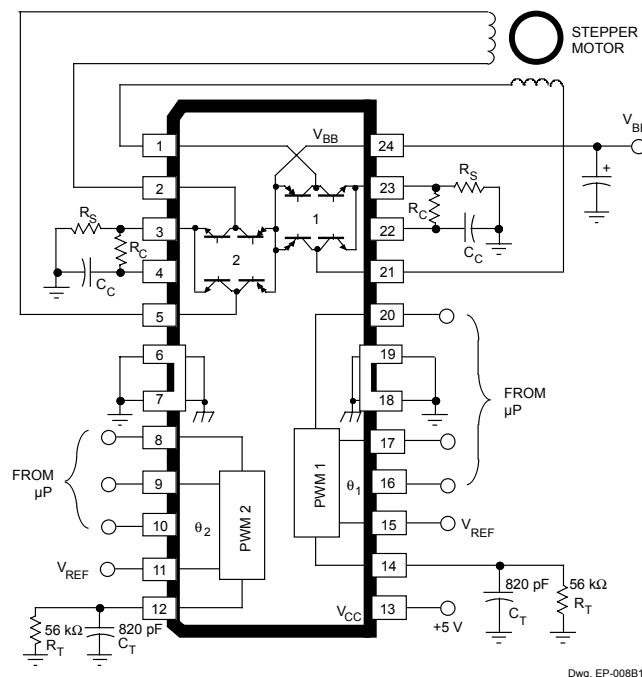

Dwg. EP-008B1

L6219DS

Dual Full-Bridge PWM Motor Driver

Selection Guide

Part Number	Packing	Operating Ambient Temperature Range T_A (°C)
L6219DS-T	31 pieces per tube	-20 to 85
L6219DSTR-T	1000 pieces per reel	-20 to 85

Absolute Maximum Ratings

Characteristic	Symbol	Notes	Rating	Units
Motor Supply Voltage	V_{BB}		45	V
Logic Supply Voltage	V_{CC}		7.0	V
Logic Input Voltage Range	V_{IN}		-0.3 to $V_{CC}+0.3$	V
Output Emitter Voltage	V_{SENSE}		1.5	V
Output Current, Peak	$I_{OUT(pk)}$		1.0	A
Output Current, Continuous	I_{OUT}	Output current rating may be limited by duty cycle, ambient temperature, and heat sinking. Under any set of conditions, do not exceed the specified peak current rating or a junction temperature of +150°C.	750	mA
Operating Ambient Temperature	T_A	Range S	-20 to 85	°C
Maximum Junction Temperature	$T_J(max)$		150	°C
Storage Temperature	T_{stg}		-55 to 150	°C

Thermal Characteristics

Characteristic	Symbol	Test Conditions*	Value	Units
Package Thermal Resistance	$R_{\theta JA}$	1-layer PCB with copper limited to solder pads	77	°C/W
		1-layer PCB with 3.57 in. ² of copper area	49	°C/W
	$R_{\theta JT}$		6	°C/W

*Additional thermal information available on the Allegro website.

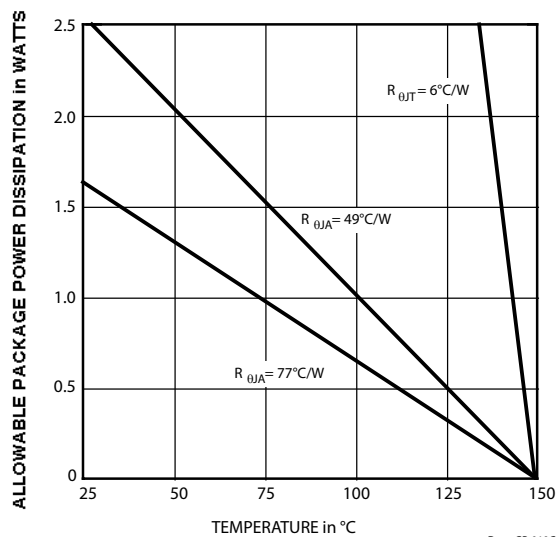

PWM Current-Control Circuitry

CHANNEL 1
TERMINAL NUMBERS
SHOWN.

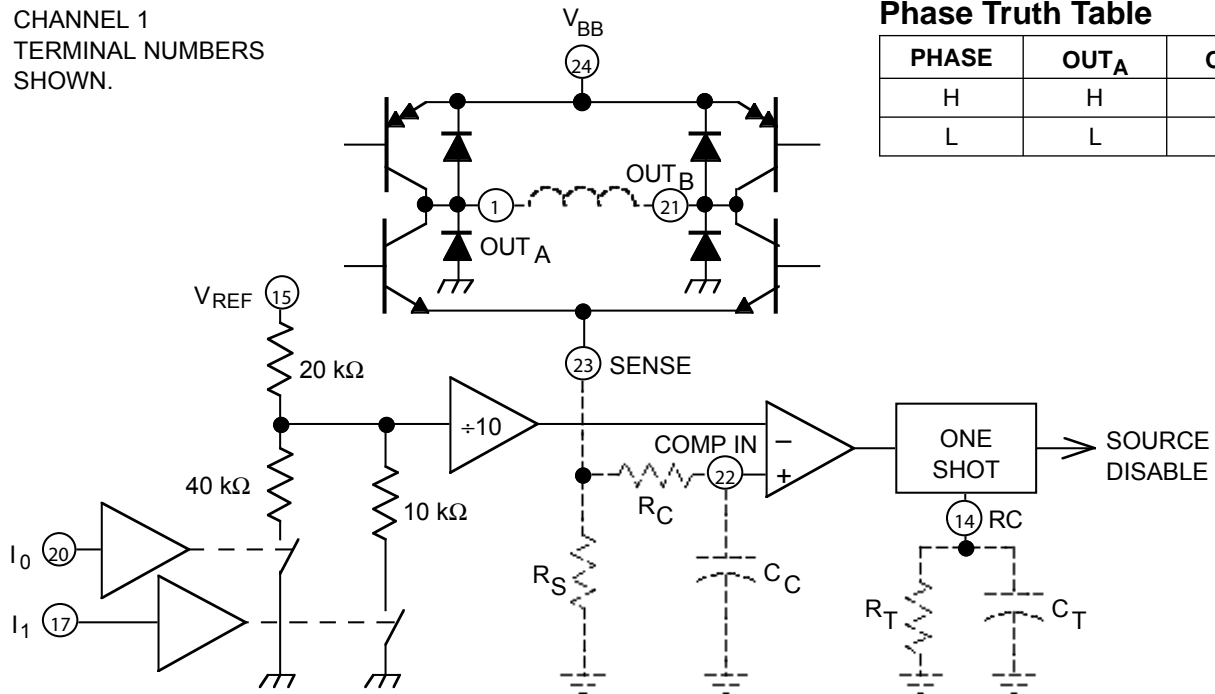

Phase Truth Table

PHASE	OUT _A	OUT _B
H	H	L
L	L	H

Dwg. EP-007-5

Pin-Out Diagram

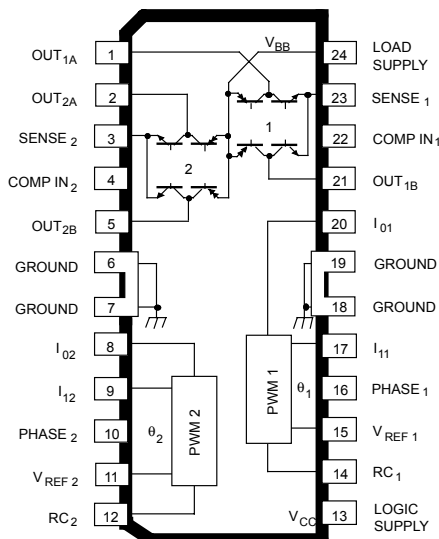

Dwg. PP-005-3

ELECTRICAL CHARACTERISTICS at $T_A = +25^\circ\text{C}$, $T_J \leq 150^\circ\text{C}$, $V_{BB} = 45\text{ V}$, $V_{CC} = 4.75\text{ V to } 5.25\text{ V}$, $V_{REF} = 5.0\text{ V}$ (unless otherwise noted).

Characteristic	Symbol	Test Conditions	Limits			
			Min.	Typ.	Max.	Units
Output Drivers (OUT_A or OUT_B)						
Motor Supply Range	V_{BB}		10	—	45	V
Output Leakage Current	I_{CEX}	$V_{OUT} = V_{BB}$	—	< 1.0	50	μA
		$V_{OUT} = 0$	—	< -1.0	-50	μA
Output Sustaining Voltage	$V_{CE(sus)}$	$I_{OUT} = \pm 750\text{ mA}$, $L = 3.0\text{ mH}$	45	—	—	V
Output Saturation Voltage	$V_{CE(SAT)}$	Sink Driver, $I_{OUT} = +500\text{ mA}$	—	0.4	0.6	V
		Sink Driver, $I_{OUT} = +750\text{ mA}$	—	1.0	1.2	V
		Source Driver, $I_{OUT} = -500\text{ mA}$	—	1.0	1.2	V
		Source Driver, $I_{OUT} = -750\text{ mA}$	—	1.3	1.5	V
Clamp Diode Leakage Current	I_R	$V_R = 45\text{ V}$	—	< 1.0	50	μA
Clamp Diode Forward Voltage	V_F	$I_F = 750\text{ mA}$	—	1.6	2.0	V
Driver Supply Current	$I_{BB(ON)}$	Both Bridges On, No Load	—	20	25	mA
	$I_{BB(OFF)}$	Both Bridges Off	—	5.0	10	mA
Control Logic						
Input Voltage	$V_{IN(1)}$	All inputs	2.4	—	—	V
	$V_{IN(0)}$	All inputs	—	—	0.8	V
Input Current	$I_{IN(1)}$	$V_{IN} = 2.4\text{ V}$	—	< 1.0	20	μA
		$V_{IN} = 0.8\text{ V}$	—	- 3.0	-200	μA
Reference Voltage Range	V_{REF}	Operating	1.5	—	7.5	V
Current Limit Threshold (at trip point)	V_{REF}/V_{COMPIN}	$I_0 = I_1 = 0.8\text{ V}$	9.5	10	10.5	—
		$I_0 = 2.4\text{ V}$, $I_1 = 0.8\text{ V}$	13.5	15	16.5	—
		$I_0 = 0.8\text{ V}$, $I_1 = 2.4\text{ V}$	25.5	30	34.5	—
Thermal Shutdown Temperature	T_J		—	170	—	$^\circ\text{C}$
Total Logic Supply Current	$I_{CC(ON)}$	$I_0 = I_1 = 0.8\text{ V}$, No Load	—	40	50	mA
	$I_{CC(OFF)}$	$I_0 = I_1 = 2.4\text{ V}$, No Load	—	10	14	mA
Fixed Off-Time	t_{off}	$R_T = 56\text{ k}\Omega$, $C_T = 820\text{ pF}$	—	46	—	μs

Applications Information

PWM Current Control

The L6219DS dual bridge is designed to drive both windings of a bipolar stepper motor. Output current is sensed and controlled independently in each bridge by an external sense resistor (R_S), internal comparator, and monostable multivibrator.

When the bridge is turned on, current increases in the motor winding and it is sensed by the external sense resistor until the sense voltage (V_{COMPIN}) reaches the level set at the comparator's input:

$$I_{TRIP} = V_{REF}/10 R_S$$

The comparator then triggers the monostable which turns off the source driver of the bridge. The actual load current peak will be slightly higher than the trip point (especially for low-inductance loads) because of the internal logic and switching delays. This delay (t_d) is typically 2 μ s. After turn-off, the motor current decays, circulating through the ground-clamp diode and sink transistor. The source driver's off time (and therefore the magnitude of the current decrease) is determined by the monostable's external RC timing components, where $t_{off} = R_T C_T$ within the range of 20 k Ω to 100 k Ω and 100 pF to 1000 pF.

The fixed-off time should be short enough to keep the current chopping above the audible range (< 46 μ s) and long enough to properly regulate the current. Because only slow-decay current control is available, short off times (< 10 μ s) require additional efforts to ensure proper current regulation. Factors that can negatively affect the ability to properly regulate the current when using short off times include: higher motor-supply voltage, light load, and longer than necessary blank time.

When the source driver is re-enabled, the winding current (the sense voltage) is again allowed to rise to the comparator's threshold. This cycle repeats itself, maintaining the average motor winding current at the desired level.

Loads with high distributed capacitances may result in high turn-on current peaks. This peak (appearing across R_S) will attempt to trip the comparator, resulting in erroneous current control or high-frequency oscillations. An external $R_C C_C$ time delay should be used to further delay the action of the comparator. Depending on load type, many applications will not require these external components (SENSE connected to COMP IN).

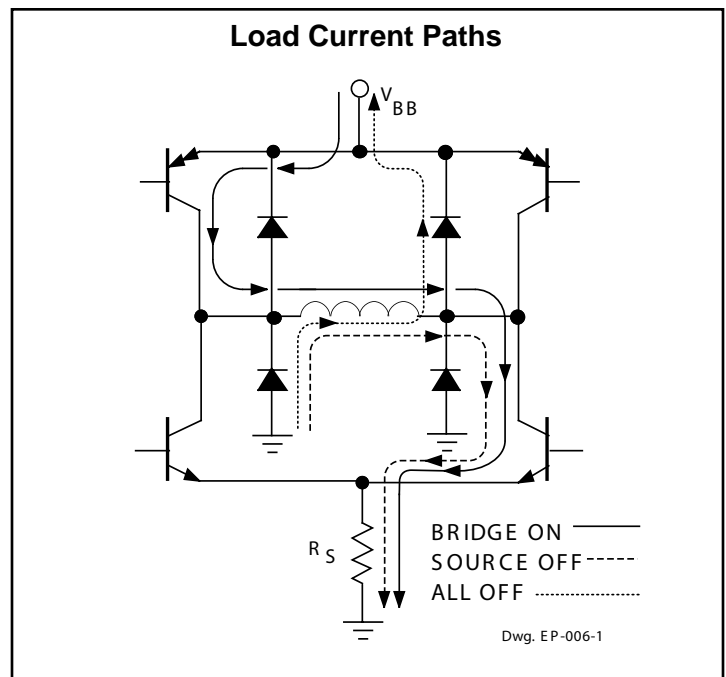
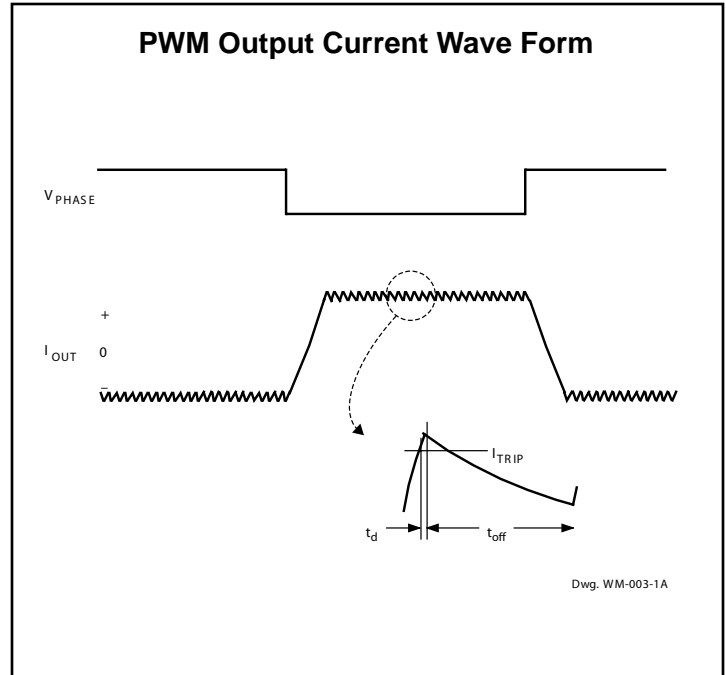

Logic Control of Output Current

Two logic level inputs (I_0 and I_1) allow digital selection of the motor winding current at 100%, 67%, 33%, or 0% of the maximum level per the table below. The 0% output current condition turns off all drivers in the bridge and can be used as an OUTPUT ENABLE function.

These logic level inputs greatly enhance the implementation of μ P-controlled drive formats.

During half-step operations, the I_0 and I_1 allow the μ P to control the motor at a constant torque between all positions in an eight-step sequence. This is accomplished by digitally selecting 100% drive current when only one phase is on and 67% drive current when two phases are on. Logic highs on both I_0 and I_1 turn off all drivers to allow rapid current decay when switching phases. This helps to ensure proper motor operation at high step rates.

The logic control inputs can also be used to select a reduced current level (and reduced power dissipation) for 'hold' conditions and/or increased current (and available torque) for start-up conditions.

Current-Control Truth Table

I_0	I_1	Output Current
L	L	$V_{REF}/10 R_S = I_{TRIP}$
H	L	$V_{REF}/15 R_S = 2/3 I_{TRIP}$
L	H	$V_{REF}/30 R_S = 1/3 I_{TRIP}$
H	H	0

General

The PHASE input to each bridge determines the direction motor winding current flows. An internally generated dead time (approximately 2 μ s) prevents crossover currents that can occur when switching the PHASE input.

All four drivers in the bridge output can be turned off between steps ($I_0 = I_1 \geq 2.4$ V) resulting in a fast current decay through the internal output clamp and flyback diodes. The fast current decay is desirable in half-step and high-speed applications. The PHASE, I_0 , and I_1 inputs float high.

Varying the reference voltage (V_{REF}) provides continuous control of the peak load current for microstepping applications.

Thermal protection circuitry turns off all drivers when the junction temperature reaches 170°C. It is only intended to protect the device from failures due to excessive junction temperature and should not imply that output short circuits are permitted. The output drivers are re-enabled when the junction temperature cools to 145°C.

The L6219DS output drivers are optimized for low output saturation voltages—less than 1.8 V total (source plus sink) at 500 mA. Under normal operating conditions, when combined with the excellent thermal properties of the fused internal lead package design, this allows continuous operation of both bridges simultaneously at 500 mA.

Application Information

Current Sensing

To minimize current sensing inaccuracies caused by ground trace IR drops, each current-sensing resistor should have a separate return to the ground terminal of the device. For low-value sense resistors, the IR drops in the PCB can be significant and should be taken into account. The use of sockets should be avoided as their contact resistance can cause variations in the effective value of R_S .

Generally, larger values of R_S reduce the aforementioned effects but can result in excessive heating and power loss in the sense resistor. The selected value of R_S should not cause the absolute maximum voltage rating of 1.5 V, for the SENSE terminal, to be exceeded. The recommended value of R_S is in the range of:

$$R_S = 0.75 / I_{TRIP(max)} \pm 50\% .$$

If desired, the reference input voltage can be filtered by placing a capacitor from REFIN to ground. The ground return for this capacitor as well as the bottom of any resistor divider used should be independent of the high-current power-ground trace to avoid changes in REFIN due to IR drops.

Thermal Considerations

For reliable operation, it is recommended that the maximum junction temperature be kept below 110°C to 125°C. The junction temperature can be measured best by attaching a thermocouple to the power pins (6, 7, 18 and 19) of the device and measuring the pin temperature, T_{TAB} . The junction temperature can then be approximated by using the formula:

$$T_J = T_{TAB} + (2 \times I_{LOAD} \times V_F \times R_{\theta JT}) ,$$

where V_F can be chosen from the electrical specification table

for the given level of I_{LOAD} . The value for $R_{\theta JT}$ is approximately 6°C/W.

The power dissipation can be improved 20% to 30% by adding a section of printed circuit board copper (typically 6 to 18 square centimeters) connected to the power pins of the device.

The thermal performance in applications that run at high load currents, high duty cycles, or both can be improved by adding external diodes from each output to ground in parallel with the internal diodes. Fast-recovery (≤ 200 ns) diodes should be used to minimize switching losses.

Load Supply Terminal

The load supply terminal, VBB, should be decoupled with an electrolytic capacitor ($\geq 47\mu F$ is recommended), placed as close to the device as is physically practical. To minimize the effect of system ground IR drops on the logic and reference input signals, the system ground should have a low-resistance return to the load supply voltage.

Fixed Off-Time Selection

With increasing values of t_{OFF} , switching losses decrease, low-level load current regulation improves, EMI reduces, PWM frequency decreases, and ripple current increases. The value of t_{OFF} can be chosen for optimization of these parameters. For applications where audible noise is a concern, typical values of t_{OFF} should be chosen in the range of 15 to 35 μs .

Package LB, 24-Pin SOICW

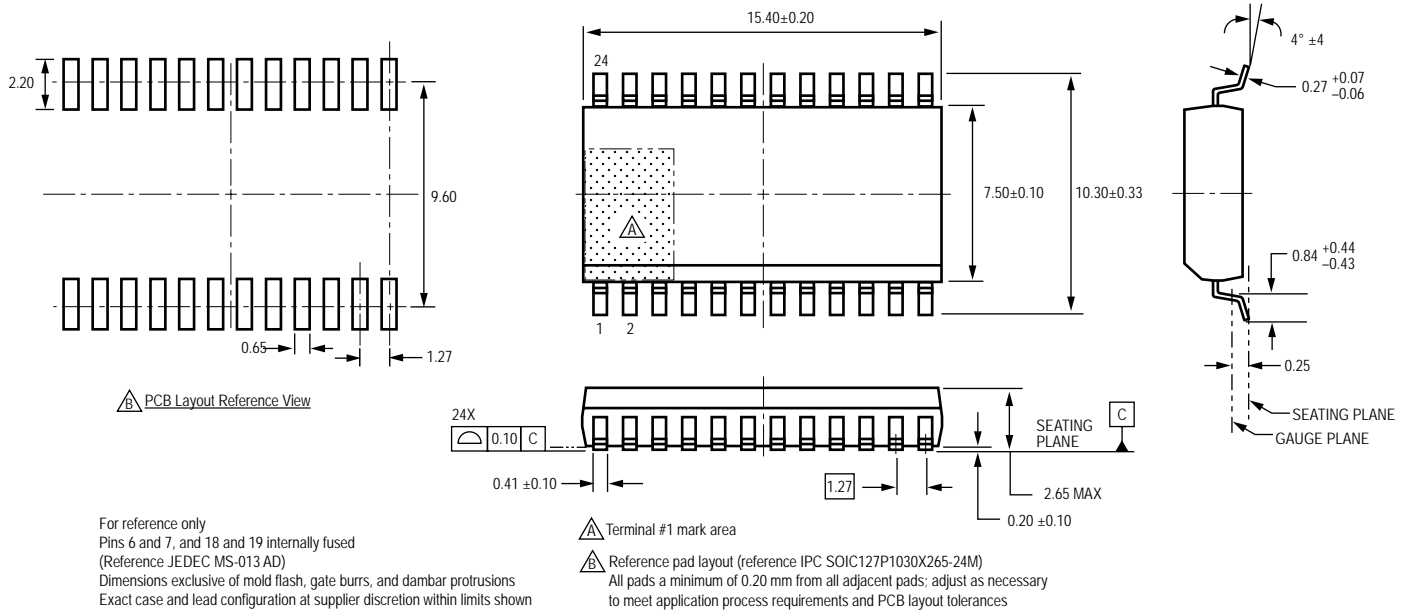

Copyright ©1998-2008, Allegro MicroSystems, Inc.

The products described here are manufactured under one or more U.S. patents or U.S. patents pending.

Allegro MicroSystems, Inc. reserves the right to make, from time to time, such departures from the detail specifications as may be required to permit improvements in the performance, reliability, or manufacturability of its products. Before placing an order, the user is cautioned to verify that the information being relied upon is current.

Allegro's products are not to be used in life support devices or systems, if a failure of an Allegro product can reasonably be expected to cause the failure of that life support device or system, or to affect the safety or effectiveness of that device or system.

The information included herein is believed to be accurate and reliable. However, Allegro MicroSystems, Inc. assumes no responsibility for its use; nor for any infringement of patents or other rights of third parties which may result from its use.

For the latest version of this document, visit our website:

www.allegromicro.com

