

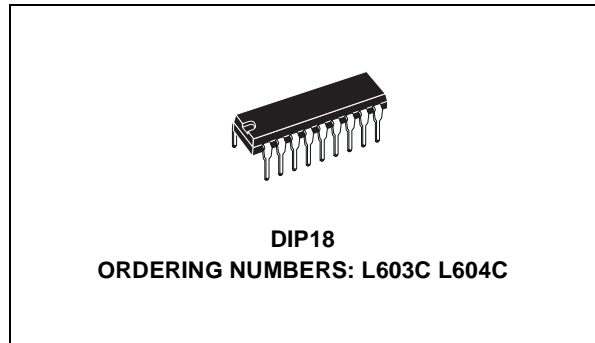

L603 - L604

DARLINGTON ARRAYS

- EIGHT DARLINGTONS PER PACKAGE
- OUTPUT CURRENT 400 mA PER DRIVER (500mA PEAK)
- OUTPUT VOLTAGE 90 V ($V_{CE(sus)} = 70$ V)
- INTEGRAL SUPPRESSION DIODES FOR INDUCTIVE LOADS
- OUTPUTS CAN BE PARALLELED FOR HIGHER CURRENT
- TTL / CMOS INPUTS
- INPUTS PINNED OPPOSITE OUTPUTS TO SIMPLIFY LAYOUT



DESCRIPTION

The L603 and L604 are high voltage, high current darlington arrays each containing eight open collector darlington pairs with common emitters. Each channel is rated at 400mA and can with stand peak currents of 500 mA.

Suppression diodes are included for inductive load driving and the inputs are pinned opposite the outputs to simplify board layout.

The four versions interface to all common logic families:

L603 = 5V TTL

L604 = 6 - 15V CMOS

These versatile devices are useful for driving a wide range of loads, including solenoids, relays DC motors, LED displays, filament lamps, thermal printheads and high power buffers.

PIN CONNECTION (top view)

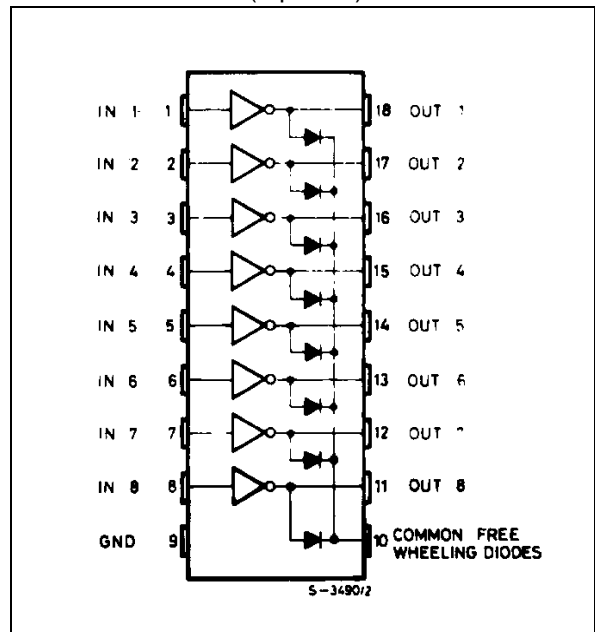

ABSOLUTE MAXIMUM RATINGS

Symbol	Parameter	Value	Unit
V_{CEX}	Collector Emitter Voltage (input open)	90	V
I_C	Collector Current	0.4	A
I_C	Collector Peak Current	0.5	A
V_i	Input Voltage (for L603 and L604)	30	V
P_{tot}	Total Power Dissipation at $T_{amb} = 25^\circ\text{C}$	1.8	W
T_{op}	Operating Junction Temperature	-25 to 150	$^\circ\text{C}$

L603 - L604

THERMAL DATA

Symbol	Parameter	Value	Unit
R _{th-j amb}	Thermal Resistance Junction ambient	max 70	°C/W

ELECTRICAL CHARACTERISTICS

Symbol	Parameter	Test Condition	Min.	Typ.	Max.	Unit
I _{CEX}	Output Leakage Current	V _{CE} = 90V			10	μA
V _{CE(sat)}	Collector Emitter Saturation Voltage	I _C = 300mA; I _B = 500μA			2	V
		I _C = 200mA; I _B = μA			1.7	V
		I _C = 100mA; I _B = 250μA			1.2	V
V _i	Maximum Input Voltage (ON condition)	V _{CE} = 3V; I _C = 300mA			2.5	V
		L603 L604			5	V
V _i	Maximum Input Voltage (OFF condition)	V _{CE} = 90V; I _C = 25μA	0.75			V
		L603 L604	1			V
I _R	Clamp Diode Reverse Current	V _R = 90V			50	μA
V _F	Clamp Diode Forward Voltage	I _F = 300mA		2	2.4	V
t _{on}	Turn-on Delay	0.5 V _i to 0.5 V _o		0.4		μs
t _{off}	Turn-off Delay	0.5 V _i to 0.5 V _o		0.4		μA

L603

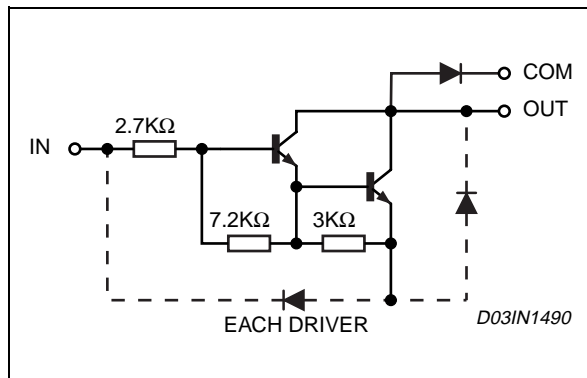

L604

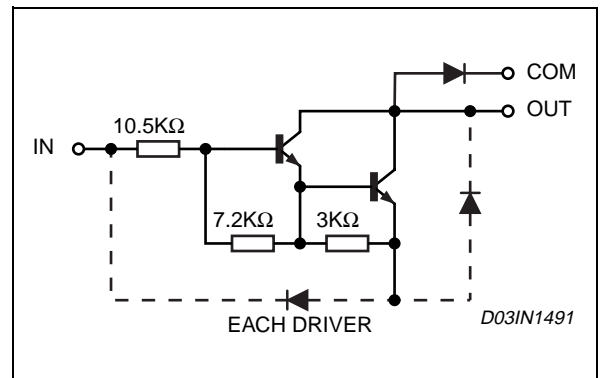

DIM.	mm			inch		
	MIN.	TYP.	MAX.	MIN.	TYP.	MAX.
a1	0.254			0.010		
B	1.39		1.65	0.055		0.065
b		0.46			0.018	
b1		0.25			0.010	
D			23.24			0.915
E		8.5			0.335	
e		2.54			0.100	
e3		20.32			0.800	
F			7.1			0.280
I			3.93			0.155
L		3.3			0.130	
Z		1.27	1.59		0.050	0.063

OUTLINE AND MECHANICAL DATA

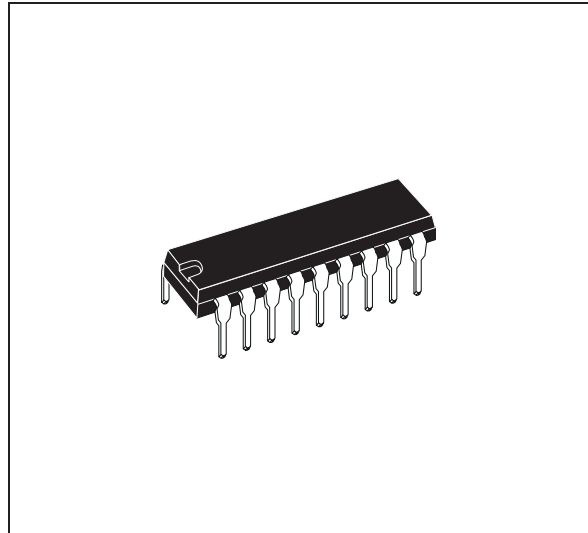

DIP18

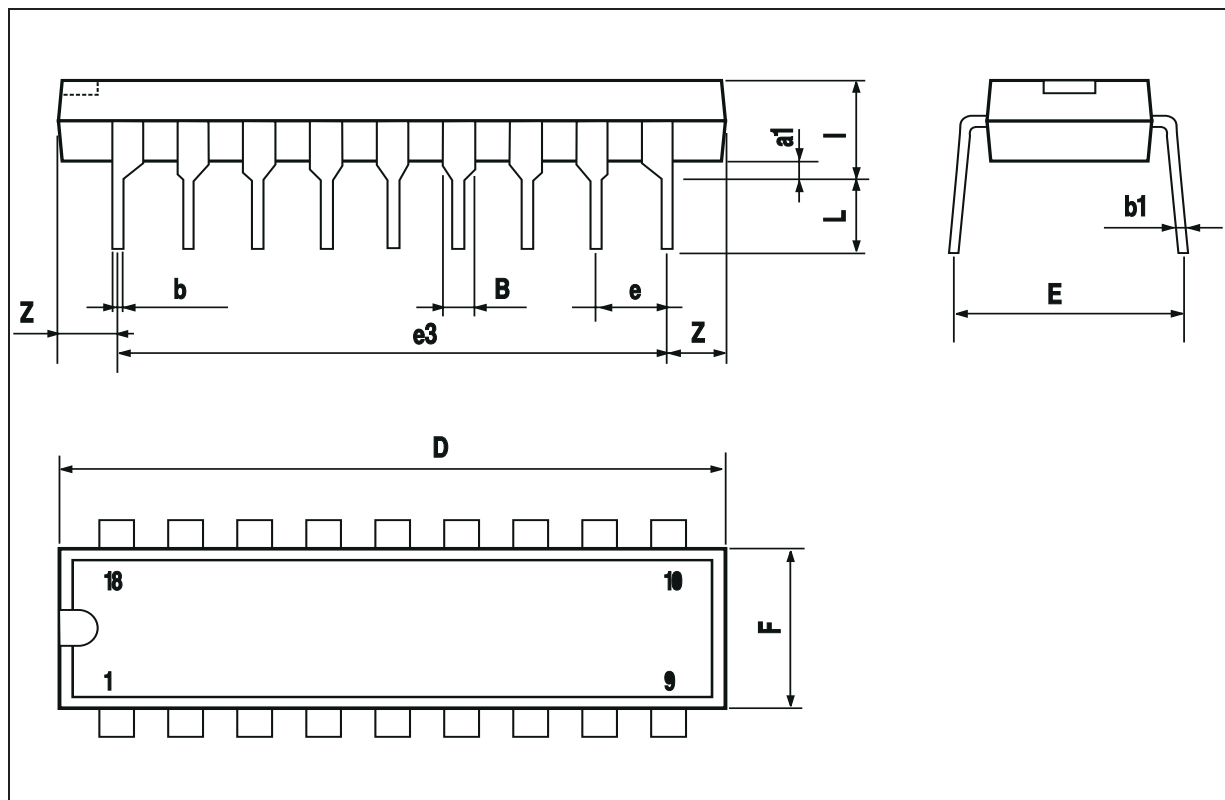

Information furnished is believed to be accurate and reliable. However, STMicroelectronics assumes no responsibility for the consequences of use of such information nor for any infringement of patents or other rights of third parties which may result from its use. No license is granted by implication or otherwise under any patent or patent rights of STMicroelectronics. Specifications mentioned in this publication are subject to change without notice. This publication supersedes and replaces all information previously supplied. STMicroelectronics products are not authorized for use as critical components in life support devices or systems without express written approval of STMicroelectronics.

The ST logo is a registered trademark of STMicroelectronics.
All other names are the property of their respective owners

© 2003 STMicroelectronics - All rights reserved

STMicroelectronics GROUP OF COMPANIES

Australia - Belgium - Brazil - Canada - China - Czech Republic - Finland - France - Germany - Hong Kong - India - Israel - Italy - Japan -
Malaysia - Malta - Morocco - Singapore - Spain - Sweden - Switzerland - United Kingdom - United States
www.st.com