

Low drop voltage regulator

Datasheet – production data

Features

Max DC supply voltage	V_S	40V
Max output voltage tolerance	ΔV_0	+/-2%
Max dropout voltage	V_{dp}	500 mV
Output current	I_0	200 mA
Quiescent current	I_{qn}	75 $\mu A^{(1)}$

1. Typical value with watchdog disabled.

- Operating DC supply voltage range 5.6V to 31V
- Reset circuit sensing the output voltage down to 1V
- Programmable reset pulse delay with external capacitor
- Watchdog
- Programmable watchdog timer with external capacitor
- Enable input for enabling/disabling the watchdog functionality
- Thermal shutdown and short circuit protection
- Wide temperature range ($T_j = -40^\circ C$ to $150^\circ C$)

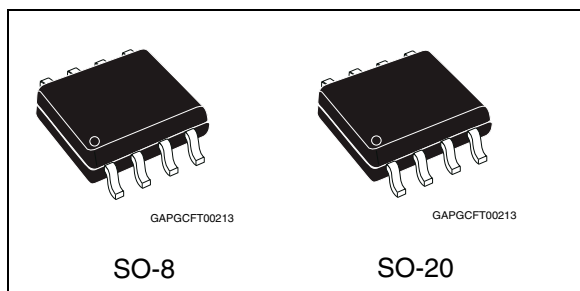

Description

The L4988 is a monolithic integrated 5V voltage regulator with a low drop voltage at currents up to 200mA. The output voltage regulating element consists in a p-channel MOS and the regulation is performed regardless of input voltage transients up to 40V. The high precision of the output voltage is obtained with a pre-trimmed reference voltage. The L4988 is protected against short circuit and an over-temperature protection switches off the device in case of extremely high power dissipation. The L4988 is active when the Enable is high. State of the art features like reset and watchdog make this device particularly suitable to supply microprocessor systems in automotive applications.

Table 1. Device summary

Package	Order codes	
	Tube	Tape & reel
SO8	L4988D	L4988DTR
SO20 (16+2+2)	L4988MD	L4988MDTR

Contents

- 1 Block diagram and pin configuration 5**

- 2 Electrical specifications 7**
 - 2.1 Absolute maximum ratings 7
 - 2.2 Thermal data 7
 - 2.3 Electrical characteristics 8
 - 2.4 Electrical characteristics curves 11
 - 2.5 Test circuit and waveforms plot 14
 - 2.5.1 Load regulation 14

- 3 Application information 16**
 - 3.1 Voltage regulator 16
 - 3.2 Reset 17
 - 3.3 Watchdog 18

- 4 Package and PCB thermal data 19**
 - 4.1 SO-8 thermal data 19
 - 4.2 SO-20 thermal data 22

- 5 Package and packing information 25**
 - 5.1 ECOPACK® packages 25
 - 5.2 SO-8 package information 25
 - 5.3 SO-20 package information 27
 - 5.4 SO-8 packing information 28
 - 5.5 SO-20 packing information 30

- 6 Revision history 31**

List of tables

Table 1.	Device summary	1
Table 2.	Pins description	6
Table 3.	Absolute maximum ratings	7
Table 4.	Thermal data	7
Table 5.	General	8
Table 6.	Reset	9
Table 7.	Watchdog	9
Table 8.	Watchdog Enable	10
Table 9.	SO-8 thermal parameter	21
Table 10.	SO-20 thermal parameter	24
Table 11.	SO-8 mechanical data	26
Table 12.	SO-20 mechanical data	27
Table 13.	Document revision history	31

List of figures

Figure 1.	Block diagram	5
Figure 2.	Pins configuration	6
Figure 3.	Output voltage vs. T_j	11
Figure 4.	Output voltage vs. V_s	11
Figure 5.	Drop Voltage vs. Output Current	11
Figure 6.	Current consumption vs. Output Current	11
Figure 7.	Current consumption vs. Input Voltage	11
Figure 8.	Current limitation vs. T_j	11
Figure 9.	Current limitation vs. Input Voltage	12
Figure 10.	Short Circuit Current vs. T_j	12
Figure 11.	Short Circuit Current vs. Input Voltage	12
Figure 12.	V_{WEn_high} vs. T_j	12
Figure 13.	V_{WEn_LOW} vs. T_j	12
Figure 14.	V_{rhth} vs. T_j	12
Figure 15.	V_{rlth} vs. T_j	13
Figure 16.	V_{whth} vs. T_j	13
Figure 17.	V_{wlth} vs. T_j	13
Figure 18.	I_{cr} & I_{cwc} vs. T_j	13
Figure 19.	I_{dr} & I_{dwd} vs. T_j	13
Figure 20.	T_{wop} vs. T_j	13
Figure 21.	PSRR	14
Figure 22.	Load regulation test circuit	14
Figure 23.	Maximum load variation response	15
Figure 24.	L4988 application schematic	16
Figure 25.	Behavior of output current versus regulated voltage V_o	17
Figure 26.	Reset timing diagram	18
Figure 27.	Watchdog timing diagram	18
Figure 28.	SO-8 PC board	19
Figure 29.	SO-8 $R_{thj-amb}$ Vs. PCB copper area in open box free air condition	19
Figure 30.	SO-8 thermal impedance junction ambient single pulse	20
Figure 31.	SO-8 thermal fitting model of a single channel	20
Figure 32.	SO-20 PC board	22
Figure 33.	SO-20 $R_{thj-amb}$ Vs. PCB copper area in open box free air condition	22
Figure 34.	SO-20 thermal impedance junction ambient single pulse	23
Figure 35.	SO-20 thermal fitting model of a single channel	23
Figure 36.	SO-8 package dimensions	25
Figure 37.	SO-20 package dimensions	27
Figure 38.	SO-8 tube shipment (no suffix)	28
Figure 39.	SO-8 tape and reel shipment (suffix "TR")	29
Figure 40.	SO-20 tube shipment (no suffix)	30
Figure 41.	SO-20 tape and reel shipment (suffix "TR")	30

1 Block diagram and pin configuration

Figure 1. Block diagram

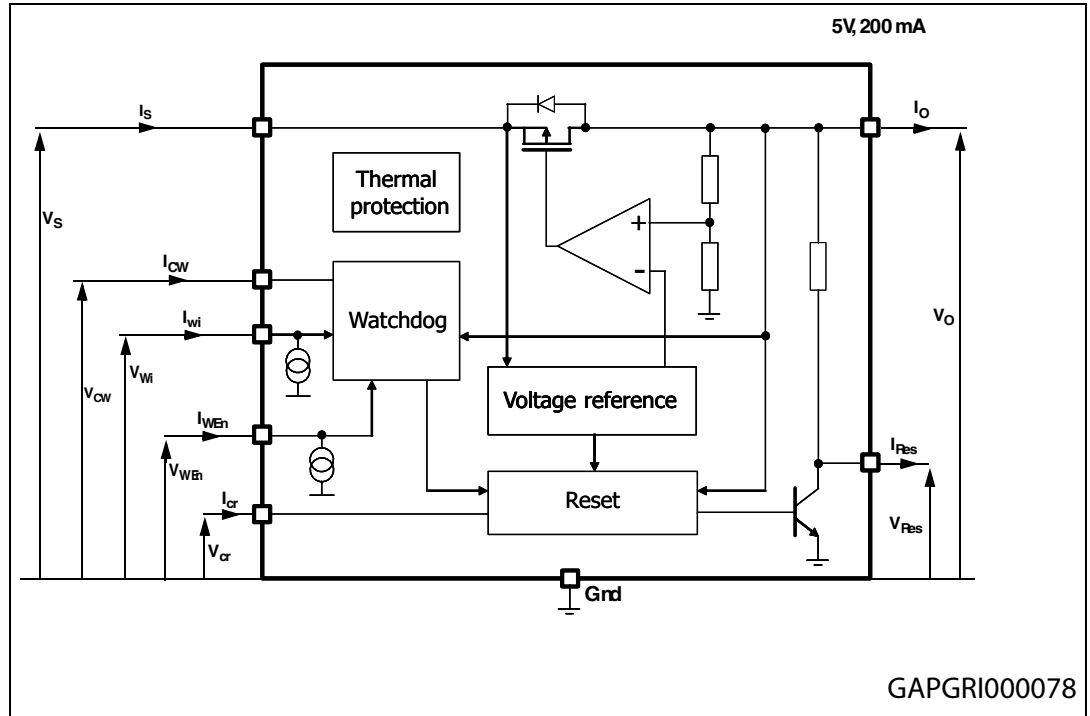
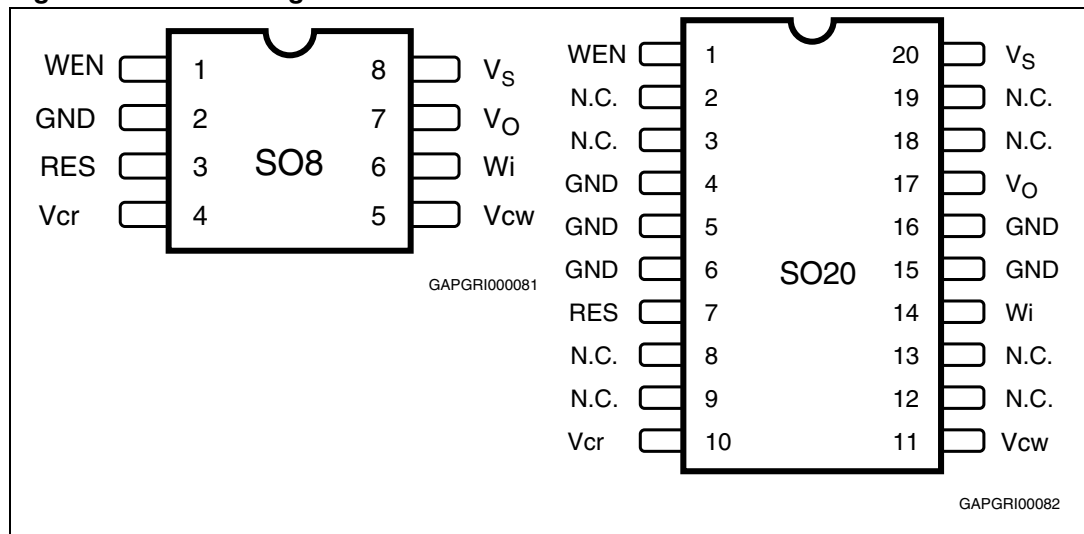

Table 2. Pins description

Pin name	SO8(D)	SO20(MD)	Function
WEn	1	1	Watchdog Enable input If high watchdog functionality is active
Gnd	2	4	Ground reference
Gnd		5, 6, 15, 16	Ground. Connected these pins to a heat spreader ground
Res	3	7	Reset output. It is pulled down when output voltage goes below Vo_th or frequency at Wi is too low.
Vcr	4	10	Reset timing adjust. A capacitor between Vcr pin and gnd, sets the reset delay time (trd)
Vcw	5	11	Watchdog timer adjust A capacitor between Vcw pin and gnd, sets the time response of the watchdog monitor.
Wi	6	14	Watchdog input. If the frequency at this input pin is too low, the Reset output is activated.
Vo	7	17	Voltage regulator output Block to ground with a capacitor >100nF (needed for regulator stability)
Vs	8	20	Supply voltage Block to ground directly at IC pin with a capacitor
N.C.		2, 3, 8, 9, 12, 13, 18, 19	Not connected

Figure 2. Pins configuration



2 Electrical specifications

2.1 Absolute maximum ratings

Table 3. Absolute maximum ratings

Symbol	Parameter	Value	Unit
V_{VSDC}	DC supply voltage	-0.3 to 40	V
I_{VSDC}	Input current	Internally limited	
V_{Vo}	DC output voltage	-0.3 to 6 ⁽¹⁾	V
I_{Vo}	DC output current	Internally limited	
V_{Wi}	Watchdog input voltage	-0.3 to $V_{Vo} + 0.3$	V
V_{Od}	Open Drain output voltage	-0.3 to $V_{Vo} + 0.3$	V
I_{Od}	Open Drain output current	Internally limited	
V_{Cr}	Reset delay voltage	-0.3 to $V_{Vo} + 0.3$	V
V_{Cw}	Watchdog delay voltage	-0.3 to $V_{Vo} + 0.3$	V
V_{WEn}	Watchdog Enable input voltage	-0.3 to $V_{Vo} + 0.3$	V
T_j	Junction temperature	-40 to 150	°C
V_{ESD}	ESD voltage level (HBM-MIL STD 883C)	±2	kV
V_{ESD}	ESD voltage level (CDM AEC-Q100-011)	750	V

1. Using the typical application schematic with $C_{out} = 10 \mu F$ and $I_{out} = 0 A$, when the regulator is switched-on, an overshoot exceeding 6 V could occur. This behavior does not impact the reliability of the regulator.

2.2 Thermal data

Table 4. Thermal data

Symbol	Parameter	S08	S016+2+2	Unit
$R_{th-jamb}$	Thermal resistance junction to ambient	130 ⁽¹⁾	51 ⁽²⁾	°C/W

1. With copper area 2 cm²; for details see [Figure 29](#).
 2. With copper area 6 cm²; for details see [Figure 33](#).

2.3 Electrical characteristics

$V_s = 5.6V$ to $31V$, $T_j = -40^\circ C$ to $+150^\circ C$ unless otherwise specified.

Table 5. General

Pin	Symbol	Parameter	Test condition	Min.	Typ.	Max.	Unit
Vo	V_{o_ref}	Output voltage	$V_s = 6$ to $31V$ $I_o = 1$ to $200mA$	4.9	5.0	5.1	V
Vo	I_{short}	Short circuit current	$V_s = 13.5V^{(1)}$	200	280	500	mA
Vo	$I_{lim}^{(2)}$	Output current limitation	$V_s = 13.5V^{(1)}$	200	350	600	mA
V_s, V_o	V_{line}	Line regulation voltage	$V_s = 6$ to $31V$ $I_o = 1$ to $200mA$			25	mV
Vo	V_{load}	Load regulation voltage	$I_o = 1$ to $200mA$			25	mV
V_s, V_o	$V_{dp}^{(3)}$	Drop voltage	$I_o = 200mA$		270	500	mV
V_s, V_o	$V_{dp}^{(3)}$	Drop voltage	$I_o = 150mA$		200	400	mV
V_s, V_o	SVR	Ripple rejection	$f_r = 100 Hz^{(4)}$		60		dB
V_s, V_o	I_{qn_200}	Quiescent current	$V_s=13.5V,$ $I_o=200mA,$ $WEn = high$		1.9	2.5	mA
V_s, V_o	I_{qn_50}	Quiescent current	$V_s=13.5V,$ $I_o= 50mA,$ $WEn = high$		500	700	μA
V_s, V_o	$I_{q_1_we}$	Quiescent current	$V_s=13.5V,$ $I_o < 1mA,$ $WEn = high$		93	200	μA
V_s, V_o	$I_{q_1_wd}$	Quiescent current	$V_s=13.5V,$ $I_o < 1mA,$ $WEn = low$		75	150	μA
	T_w	Thermal protection temperature		150		190	$^\circ C$
	T_w_hy	Thermal protection temperature hysteresis			10		$^\circ C$

1. See [Figure 3](#).
2. Measured output current when the output voltage has dropped 100mV from its nominal value obtained at $V_s=13.5V$ and $I_o= 75mA$.
3. V_s-V_o measured when the output voltage has dropped 100mV from its nominal value obtained at $V_s=13.5V$ and $I_o= 75mA$.
4. Guaranteed by design.

Table 6. Reset

Pin	Symbol	Parameter	Test condition	Min.	Typ.	Max.	Unit
Res	Vres_l	Reset output low voltage	$R_{ext} = 5k\Omega$ to V_o , $V_o > 1V$			0.4	V
Res	I_{Res_h}	Reset output high leakage current	$V_{Res} = 5V$			1	μA
Res	R_p_u	Pull up internal resistance	With respect to V_o	12	25	50	$k\Omega$
Res	V_o_th	V_o out of regulation threshold	$V_s = 6$ to $31V$, $I_o = 1$ to $200mA$	6%	8%	10%	Below V_{o_ref}
Vcr	Vrlth	Reset timing low threshold	$V_s = 13.5V$	10%	13%	16%	V_{o_ref}
Vcr	Vrhth	Reset timing high threshold	$V_s = 13.5V$	44%	47%	50%	V_{o_ref}
Vcr	Icr	Charge current	$V_s = 13.5V$	8	17.6	30	μA
Vcr	Idr	Discharge current	$V_s = 13.5V$	8	17.6	30	μA
Res	Trr_2	Reset reaction time ⁽¹⁾	$V_o = V_{o_th} - 100mV$	100	275	1000	μs
Res	Trd	Reset delay time	$V_s = 13.5V$, $C_{tr} = 1nF$	65		150	ms

1. When V_o becomes lower than 4V, the reset reaction time decreases down to 2 μs assuring a faster reset condition in this particular case.

Table 7. Watchdog

Pin	Symbol	Parameter	Test condition	Min.	Typ.	Max.	Unit
Wi	Vih	Input high voltage	$V_s = 13.5V$	3.5			V
Wi	Vil	Input low voltage	$V_s = 13.5V$			1.5	V
Wi	Vih	Input hysteresis	$V_s = 13.5V$		500		mV
Wi	li	Pull down current	$V_s = 13.5V$		10	20	μA
Vcw	Vwhth	High threshold	$V_s = 13.5V$	44%	47%	50%	V_{o_ref}
Vcw	Vwlth	Low threshold	$V_s = 13.5V$	10%	13%	16%	V_{o_ref}
Vcw	Icwc	Charge current	$V_s = 13.5V$, $V_{cw} = 0.1V$	4	8	14	μA
Vcw	Icwd	Discharge current	$V_s = 13.5V$, $V_{cw} = 2.5V$	1.0	2.1	4.5	μA
Vcw	Twop	Watchdog period	$V_s = 13.5V$, $C_{tw} = 47nF$	25	50	90	ms
Res	twol	Watchdog output low time	$V_s = 13.5V$, $C_{tw} = 47nF$	6	10.5	22	ms

Table 8. Watchdog Enable

Pin	Symbol	Parameter	Test condition	Min.	Typ.	Max.	Unit
WEn	V _{En_l}	Enable input low voltage				1	V
WEn	V _{En_h}	Enable input high voltage		3			V
WEn	V _{En_hy}	Enable input hysteresis		500	800	1100	mV
WEn	I _{leak}	Pull down current	WEn = 5V	2	8	20	μA

2.4 Electrical characteristics curves

Figure 3. Output voltage vs. Tj

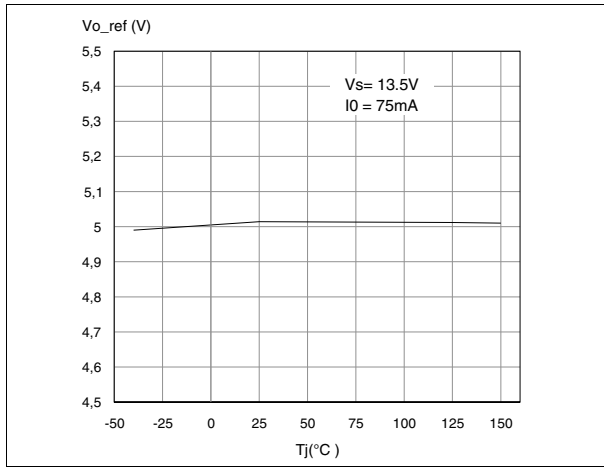

Figure 4. Output voltage vs. Vs

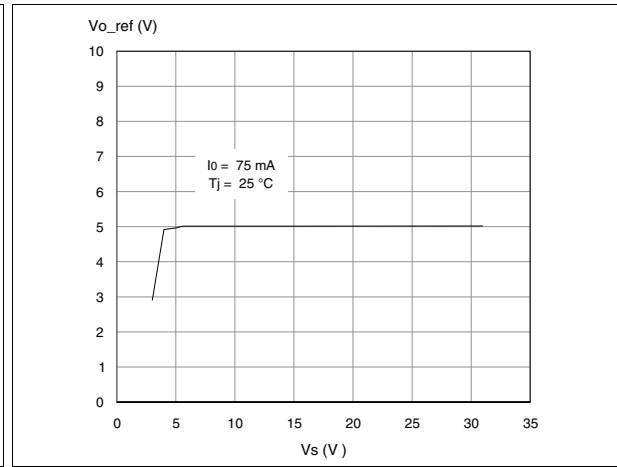

Figure 5. Drop Voltage vs. Output Current

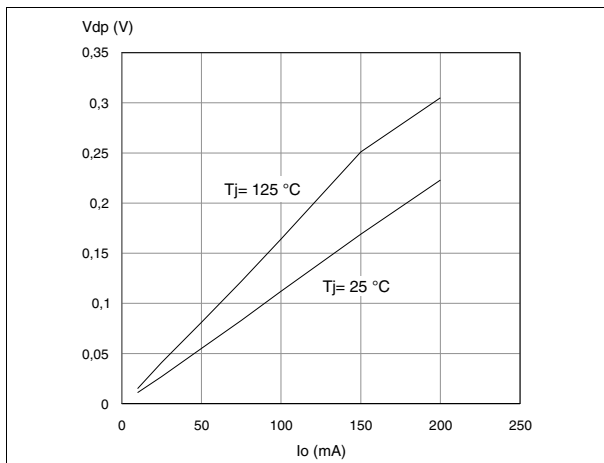

Figure 6. Current consumption vs. Output Current

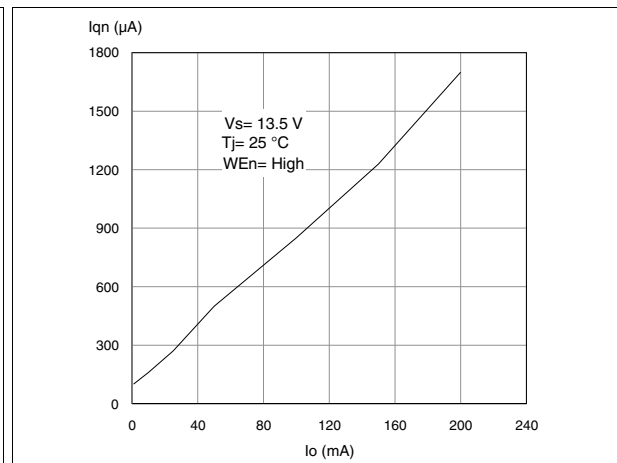

Figure 7. Current consumption vs. Input Voltage

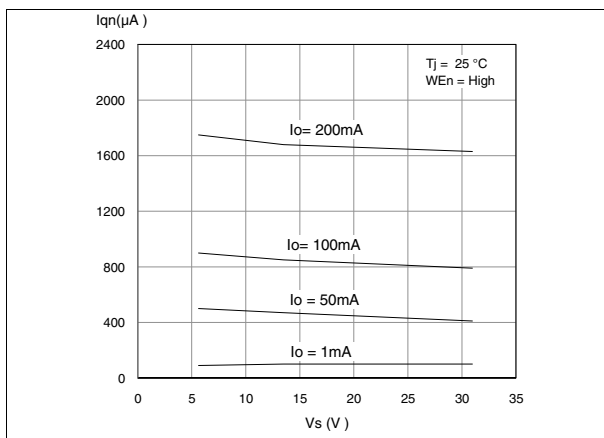

Figure 8. Current limitation vs. Tj

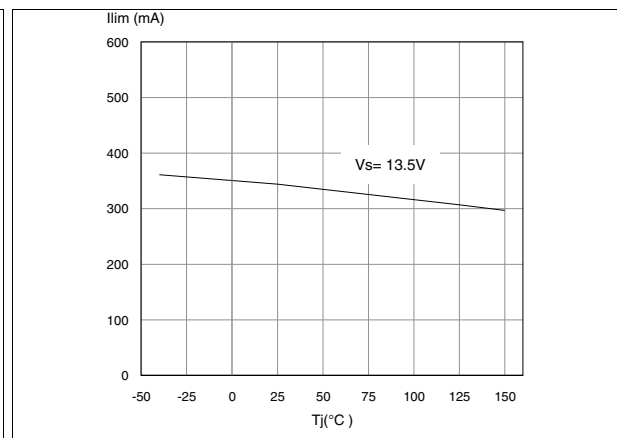

Figure 9. Current limitation vs. Input Voltage Figure 10. Short Circuit Current vs. Tj

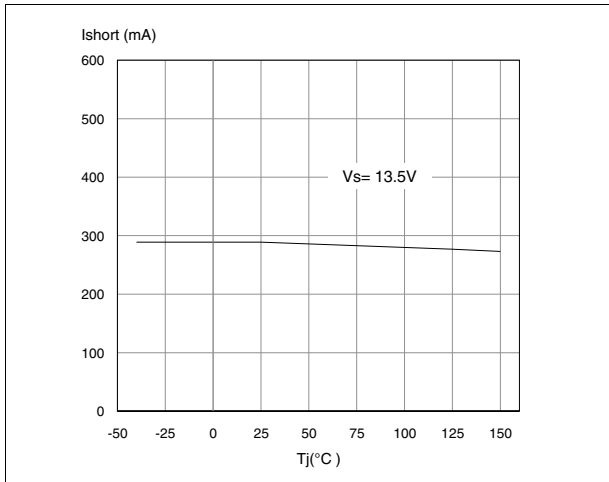
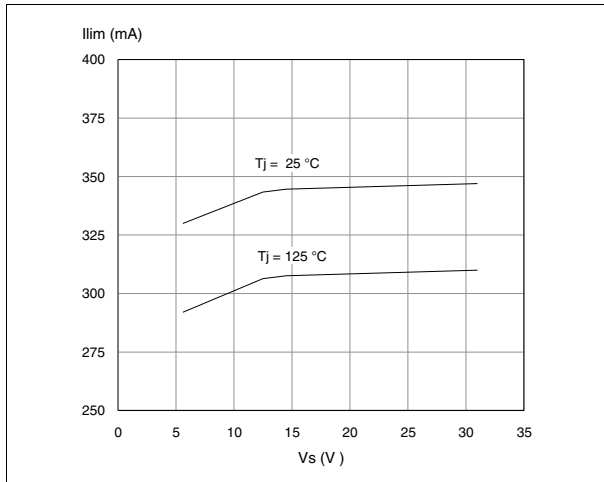

Figure 11. Short Circuit Current vs. Input Voltage

Figure 12. V_{WEN_high} vs. Tj

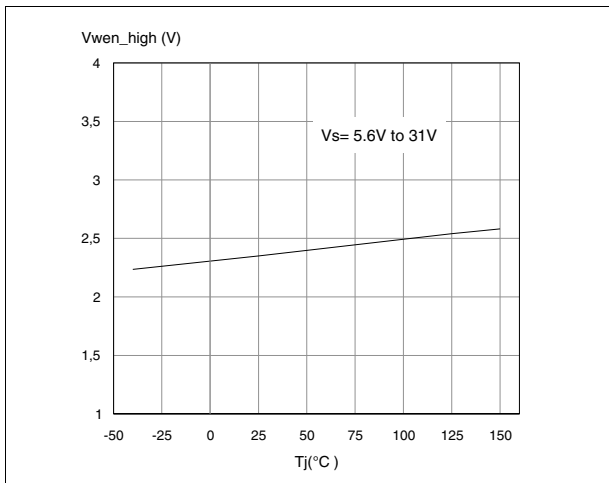
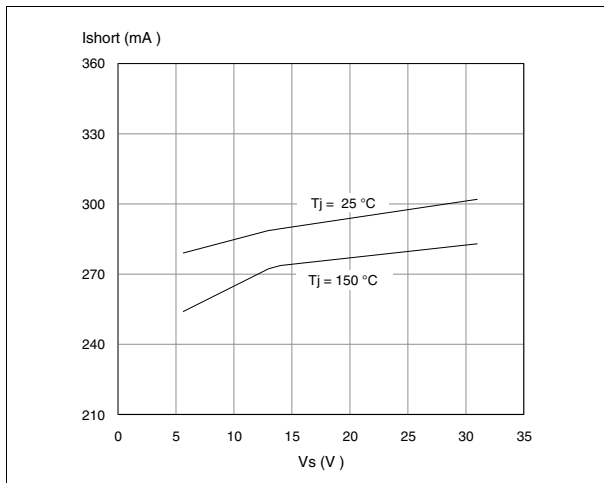

Figure 13. V_{WEN_LOW} vs. Tj

Figure 14. V_{rhth} vs. Tj

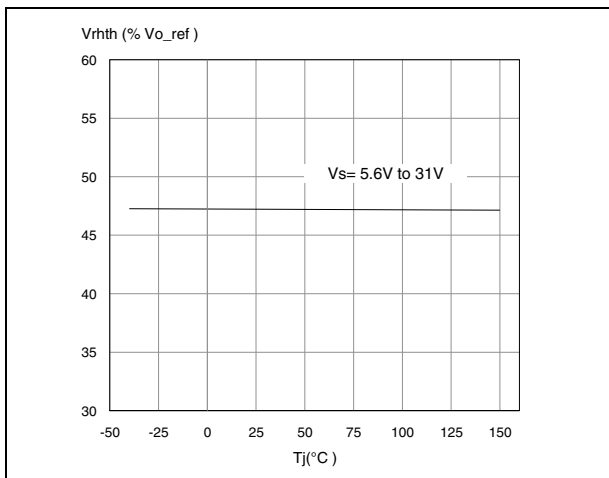
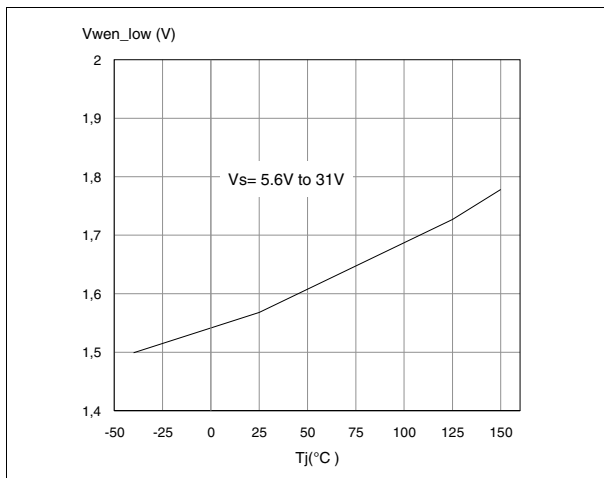

Figure 15. Vr1th vs. Tj

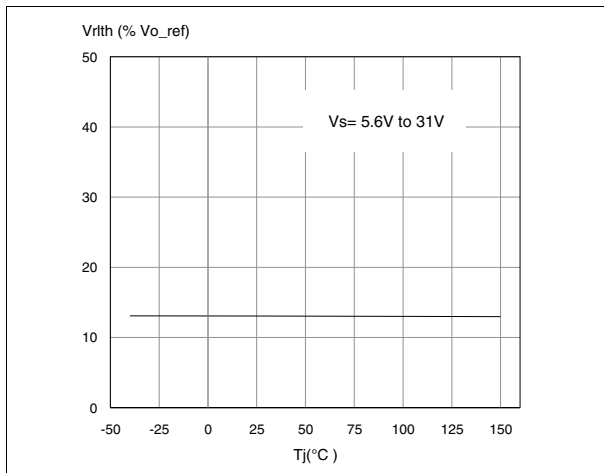

Figure 16. Vw1th vs. Tj

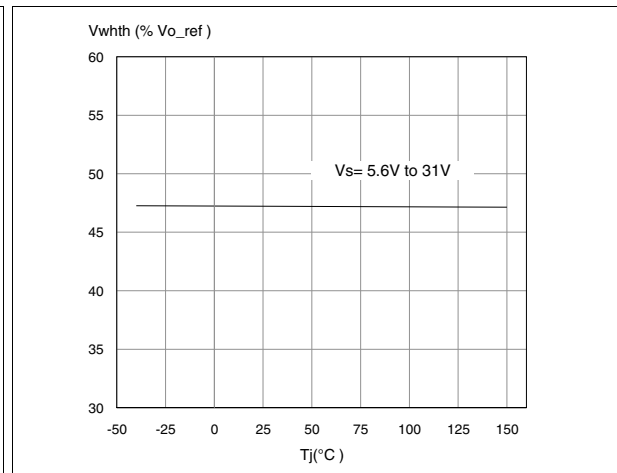

Figure 17. Vw1th vs. Tj

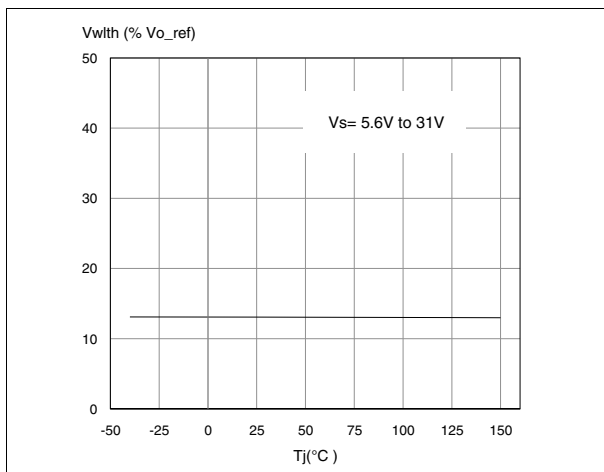

Figure 18. Icr & Icw vs. Tj

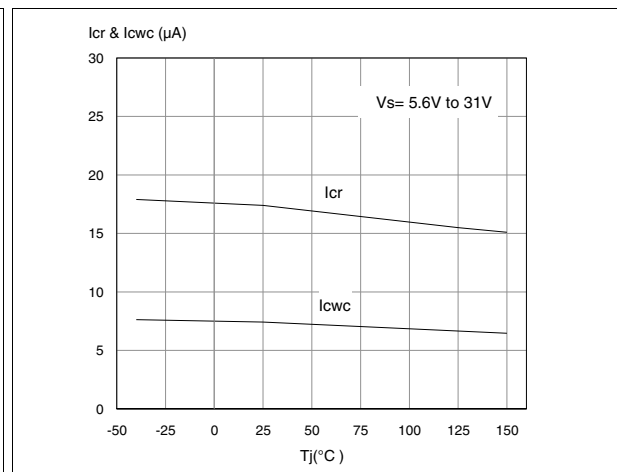

Figure 19. Idr & Icd vs. Tj

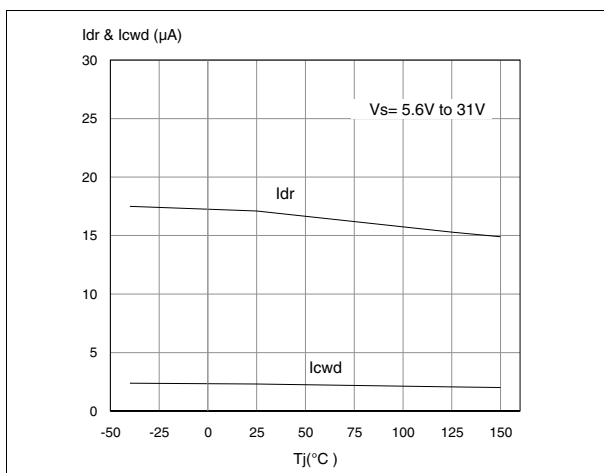

Figure 20. Twop vs. Tj

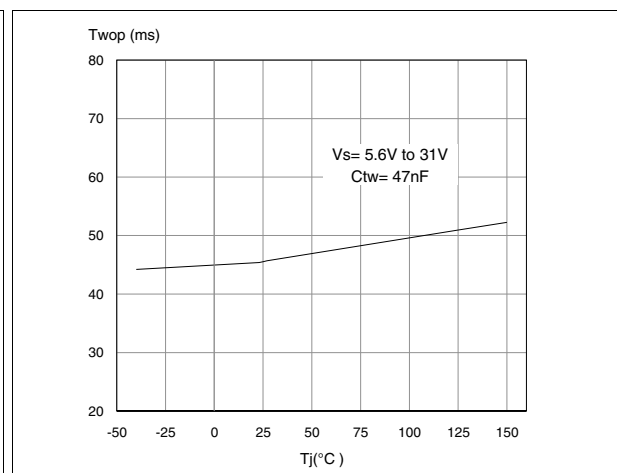
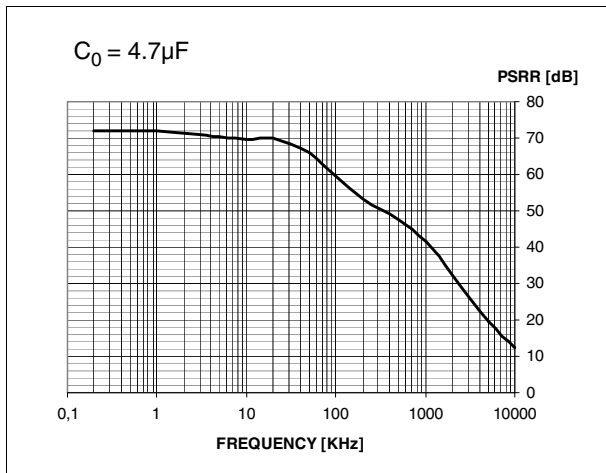

Figure 21. PSRR



2.5 Test circuit and waveforms plot

2.5.1 Load regulation

Figure 22. Load regulation test circuit

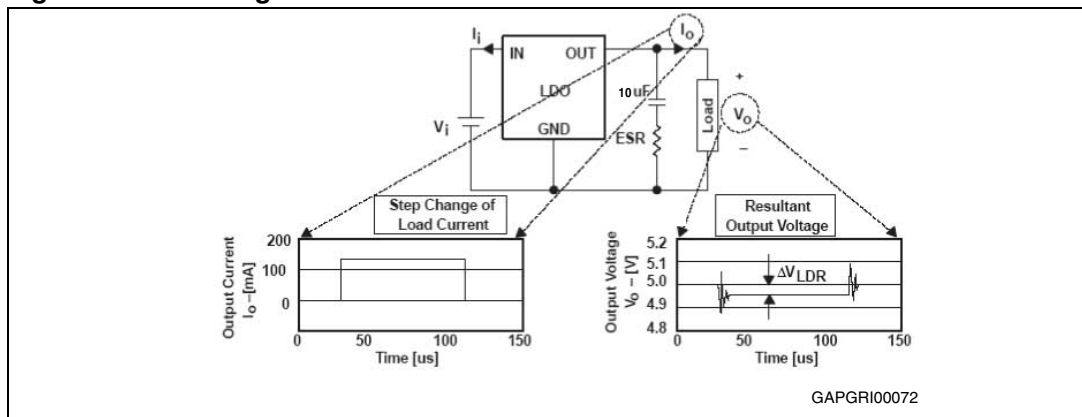
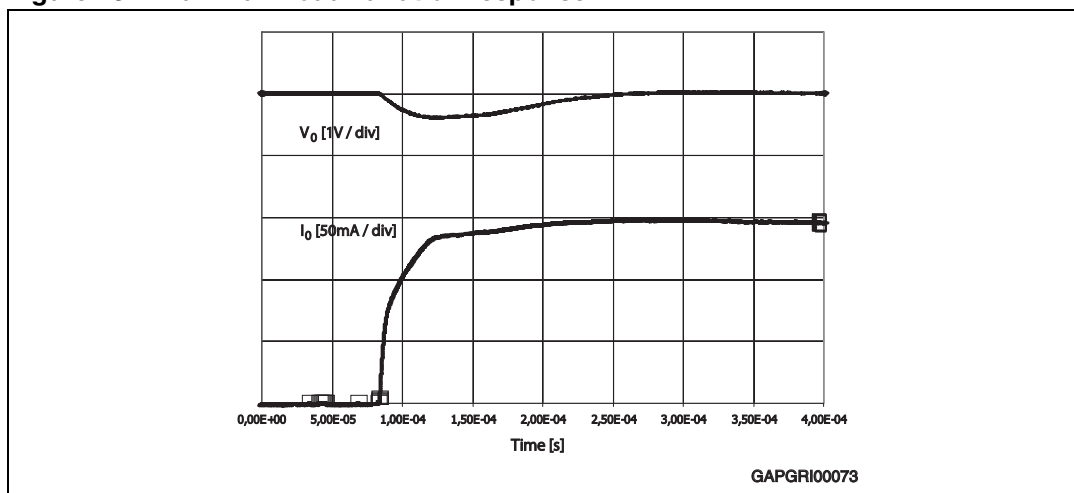
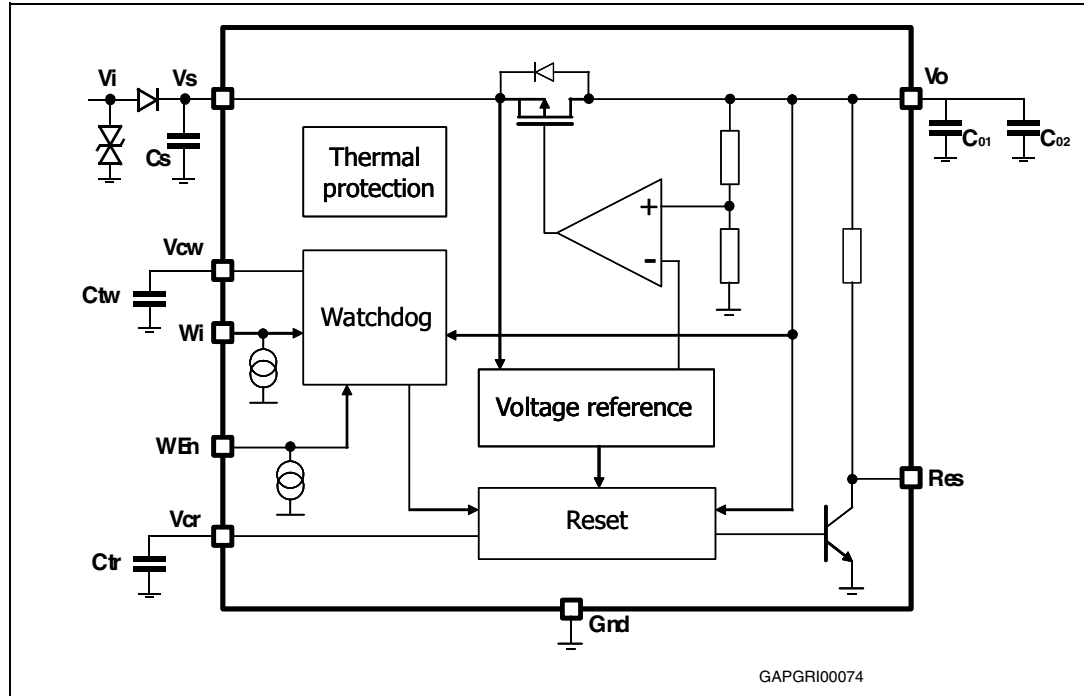

Figure 23. Maximum load variation response



3 Application information

Figure 24. L4988 application schematic



Note: The input capacitor $C_s > 200\text{nF}$ is necessary for the smoothing of line disturbances. The output capacitor $C_{01} > 100\text{nF}$ is necessary for the stability of the regulation loop. In order to damp output voltage oscillations during high load current surges, it is recommended to put an additional electrolytic capacitor $C_{02} > 10\mu\text{F}$ at the output pin.

3.1 Voltage regulator

Voltage regulator uses a p-channel mos transistor as a regulating element. With this structure a very low dropout voltage at currents up to 200mA is obtained. The output voltage is regulated up to transient input supply voltage of 40V. No functional interruption due to over-voltage pulses is generated. A short circuit protection to GND is provided. The high precision of the output voltage is obtained with a pre-trimmed reference voltage.

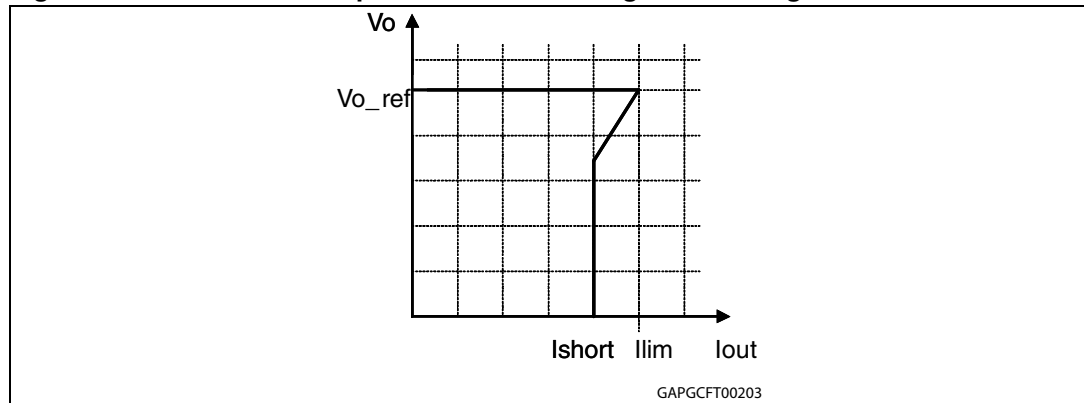
Figure 25. Behavior of output current versus regulated voltage V_o 

3.2 Reset

The reset circuit supervises the output voltage V_o . The V_{o_th} reset threshold is defined with the internal reference voltage and a resistor output divider. If the output voltage becomes lower than V_{o_th} then Res goes low with a reaction time t_{rr} . The reset low signal is guaranteed for an output voltage V_o greater than 1V.

When the output voltage becomes higher than V_{o_th} then Res goes high with a delay t_{rd} . This delay is obtained by an internal oscillator.

The oscillator period is given by:

$$T_{osc} = [(V_{rhth} - V_{rlth}) \times C_{tr}] / I_{cr} + [(V_{rhth} - V_{rlth}) \times C_{tr}] / I_{dr}$$

where:

I_{cr} : is an internally generated charge current

I_{dr} : is an internally generated discharge current

V_{rhth} , V_{rlth} : are two voltages defined with the output voltage and a resistor output divider

C_{tr} : is an external capacitance.

t_{rd} is given by:

$$t_{rd} = 512 \times T_{osc}$$

Reset is active when E_n is high.

Figure 26. Reset timing diagram

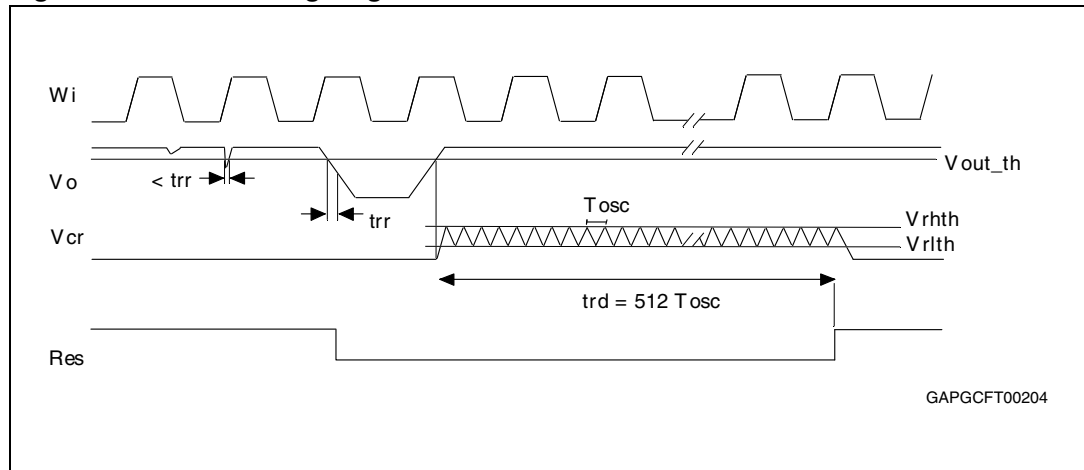

3.3 Watchdog

A connected microcontroller is monitored by the watchdog input W_i . If pulses are missing, the Reset output pin is set to low. The pulse sequence time can be set within a wide range with the external capacitor, C_{tw} . The watchdog circuit discharges the capacitor C_{tw} , with the constant current I_{cld} . If the lower threshold V_{wlth} is reached, a watchdog reset is generated. To prevent this the microcontroller must generate a positive edge during the discharge of the capacitor before the voltage has reached the threshold V_{wlth} . In order to calculate the minimum time t , during which the micro-controller must output the positive edge, the following equation can be used:

$$(V_{whth} - V_{wlth}) \times C_{tw} = I_{cld} \times t$$

Every W_i positive edge switches the current source from discharging to charging. The same happens when the lower threshold is reached. When the voltage reaches the upper threshold, V_{whth} , the current switches from charging to discharging. The result is a saw-tooth voltage at the watchdog timer capacitor C_{tw} .

Figure 27. Watchdog timing diagram

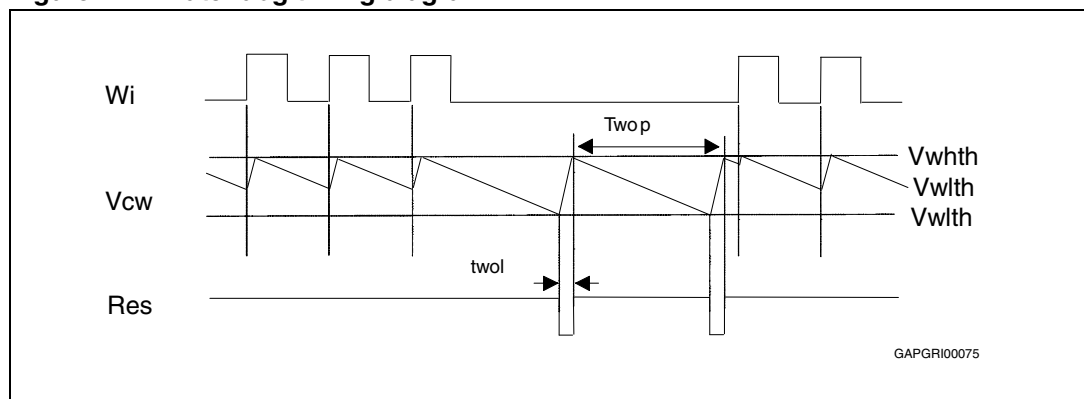

4 Package and PCB thermal data

4.1 SO-8 thermal data

Figure 28. SO-8 PC board

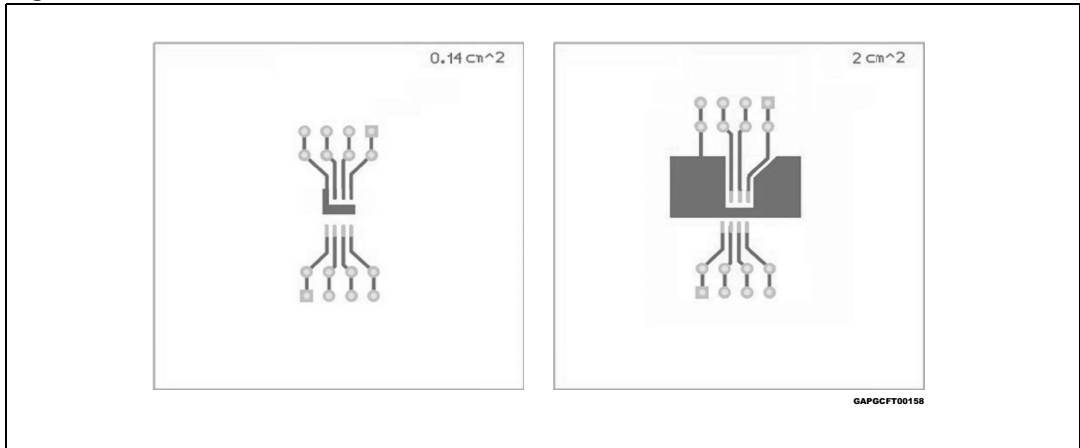

Note: Layout condition of R_{th} and Z_{th} measurements (PCB FR4 area= 58mm x 58mm, PCB thickness = 2mm, Cu thickness = 35 μ m, Copper areas: from minimum pad lay-out to 8cm²)

Figure 29. SO-8 $R_{thj-amb}$ Vs. PCB copper area in open box free air condition

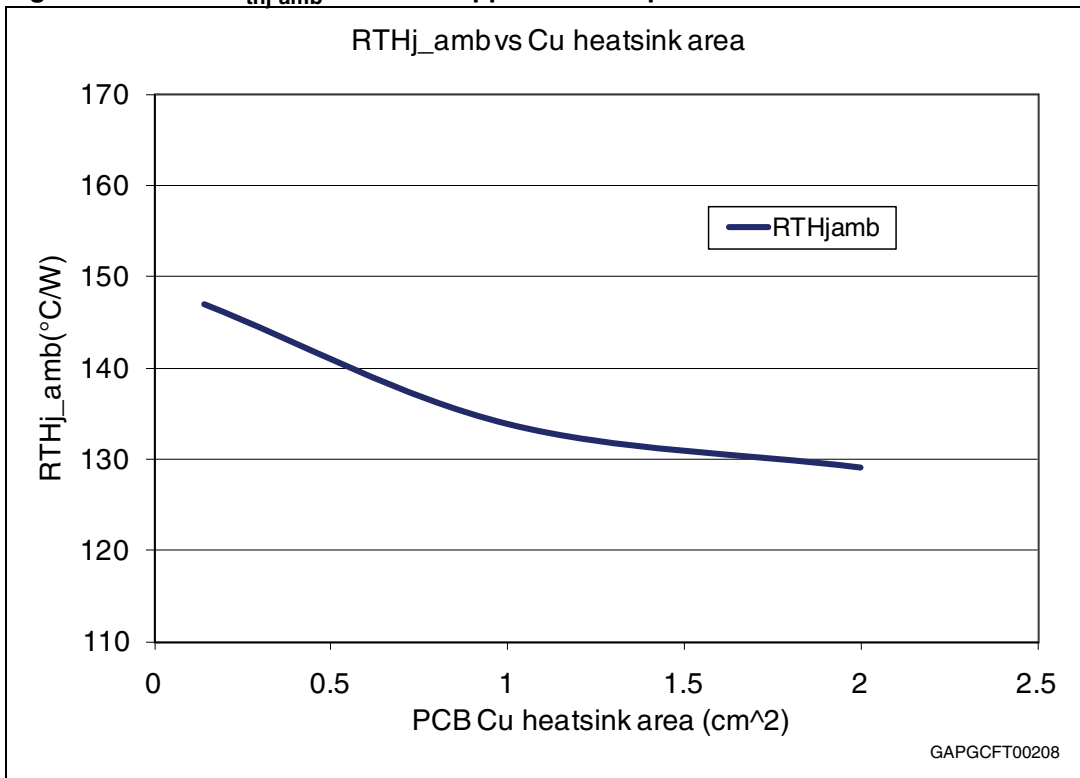
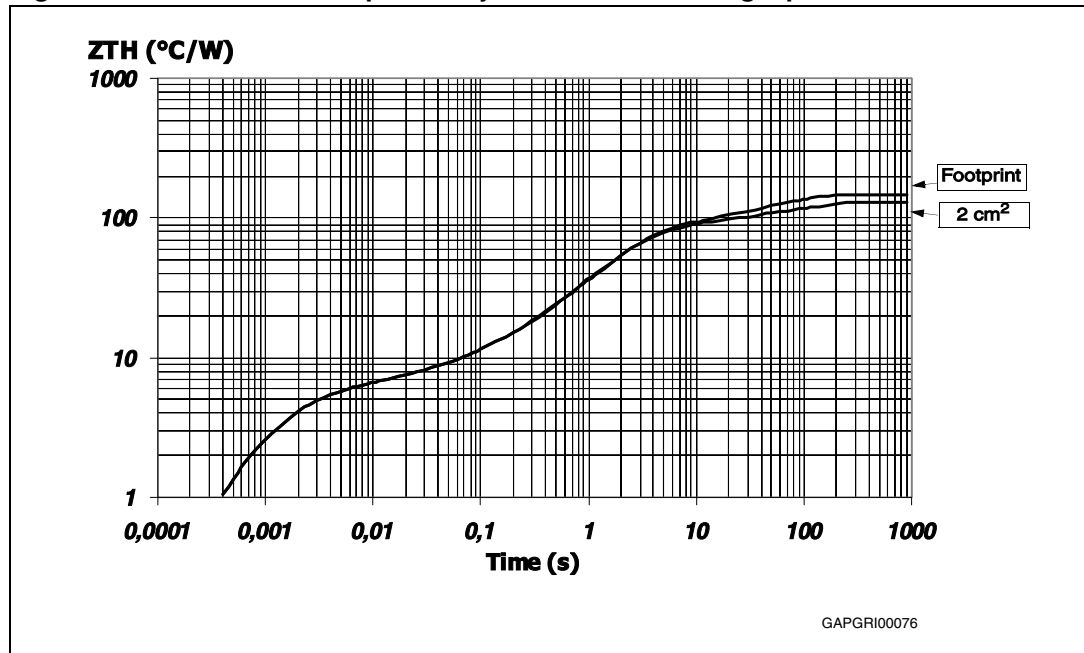

Figure 30. SO-8 thermal impedance junction ambient single pulse



Equation 1: pulse calculation formula

$$Z_{TH\delta} = R_{TH} \cdot \delta + Z_{THtp}(1 - \delta)$$

where $\delta = t_p/T$

Figure 31. SO-8 thermal fitting model of a single channel

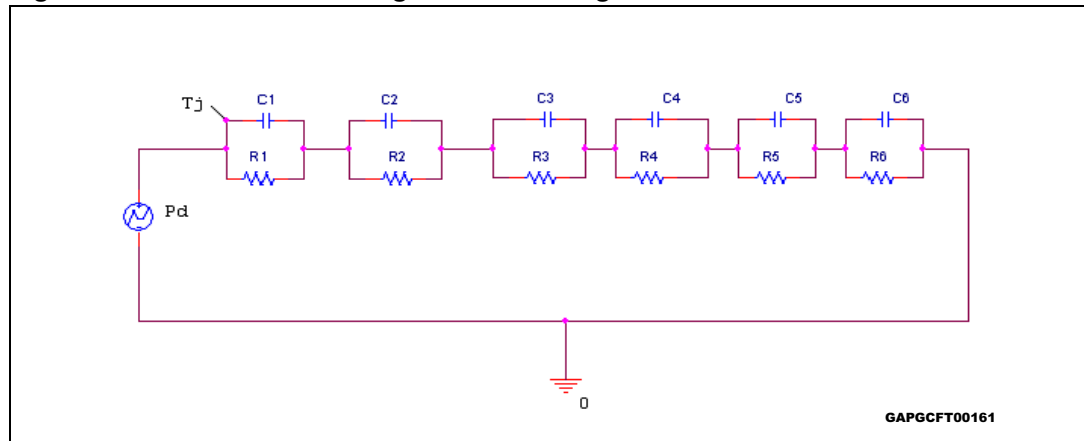
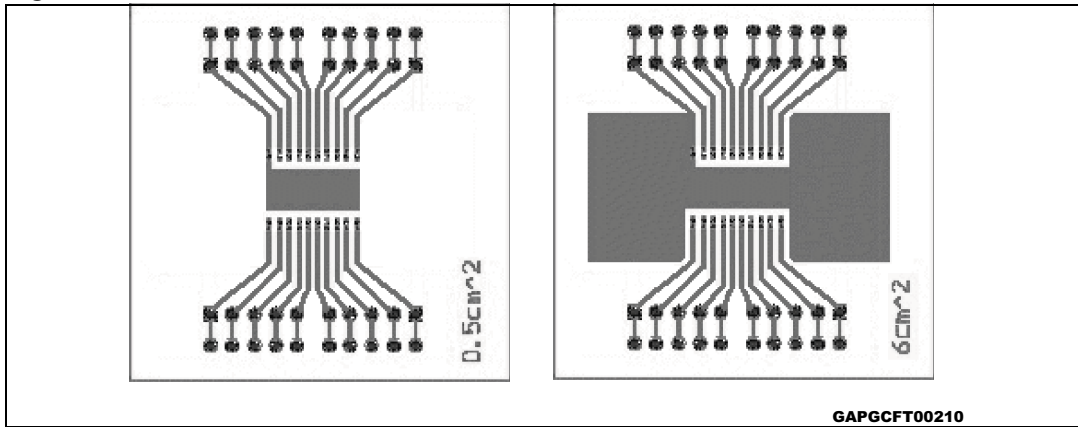

Table 9. SO-8 thermal parameter

Area/island (cm²)	Footprint	2
R1 (°C/W)	4.21	
R2 (°C/W)	2.11	
R3 (°C/W)	2	
R4 (°C/W)	41	
R5 (°C/W)	40	
R6 (°C/W)	58	40
C1 (W.s/°C)	0.00029	
C2 (W.s/°C)	0.0024	
C3 (W.s/°C)	0.03	
C4 (W.s/°C)	0.04	
C5 (W.s/°C)	0.1	
C6 (W.s/°C)	1.05	2

4.2 SO-20 thermal data

Figure 32. SO-20 PC board



Note: Layout condition of R_{th} and Z_{th} measurements (PCB FR4 area= 58mm x 58mm, PCB thickness = 2mm, Cu thickness=35 μ m , Copper areas: from minimum pad lay-out to 8cm²).

Figure 33. SO-20 $R_{thj-amb}$ Vs. PCB copper area in open box free air condition

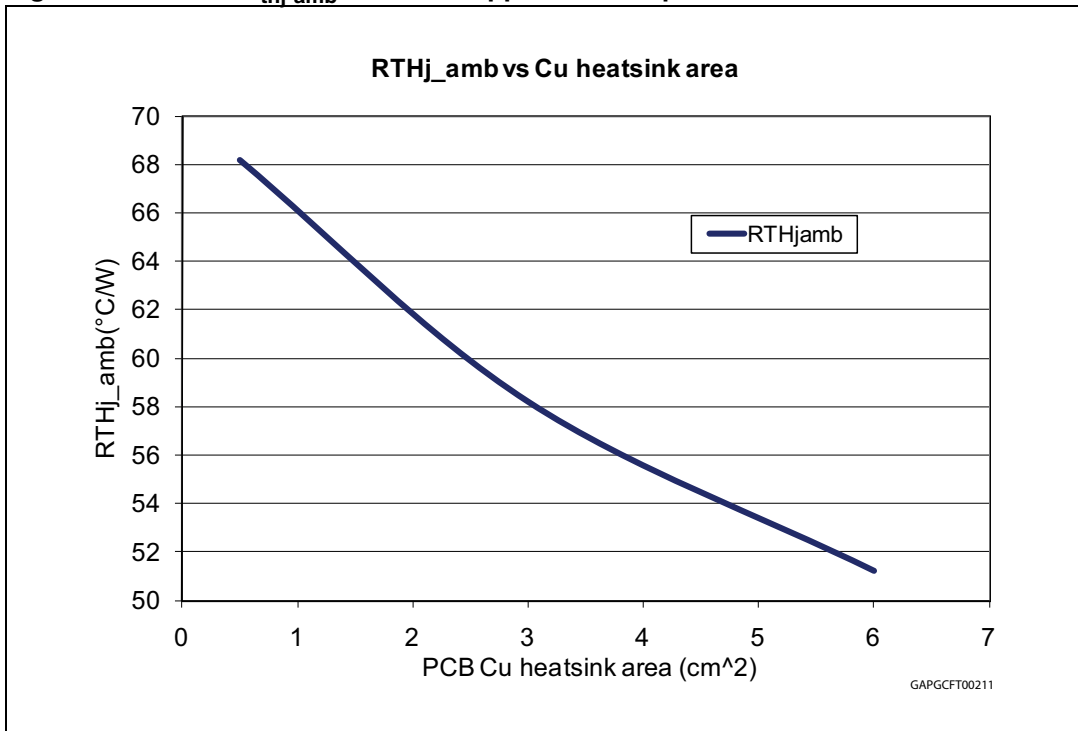
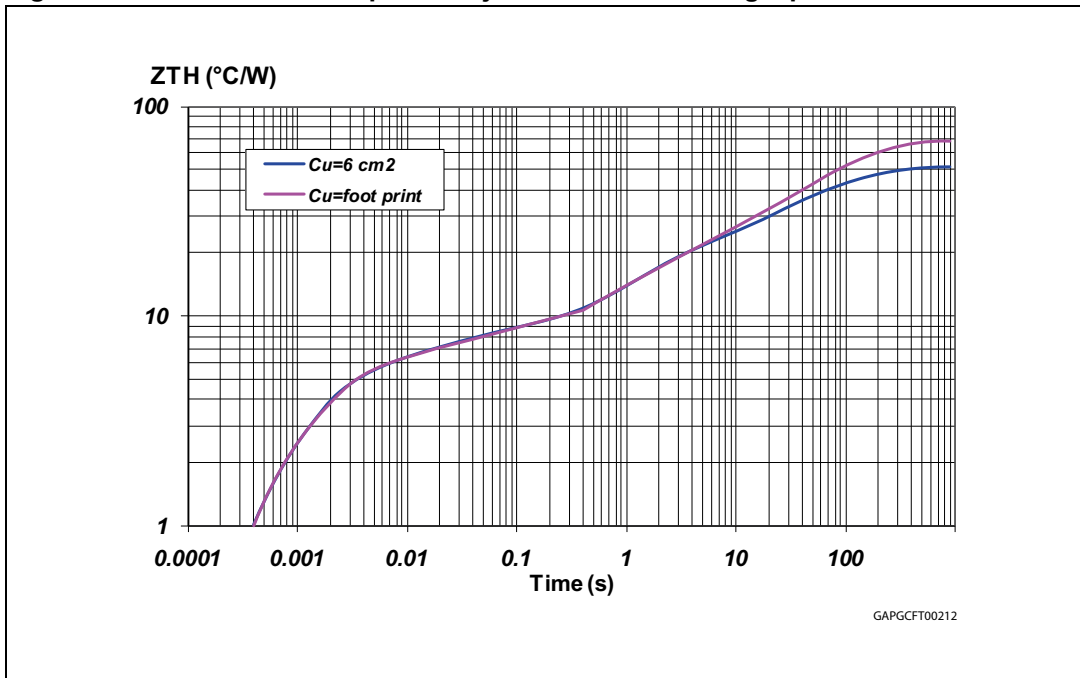

Figure 34. SO-20 thermal impedance junction ambient single pulse



Equation 2: pulse calculation formula

$$Z_{TH\delta} = R_{TH} \cdot \delta + Z_{THtp}(1 - \delta)$$

where $\delta = t_p/T$

Figure 35. SO-20 thermal fitting model of a single channel

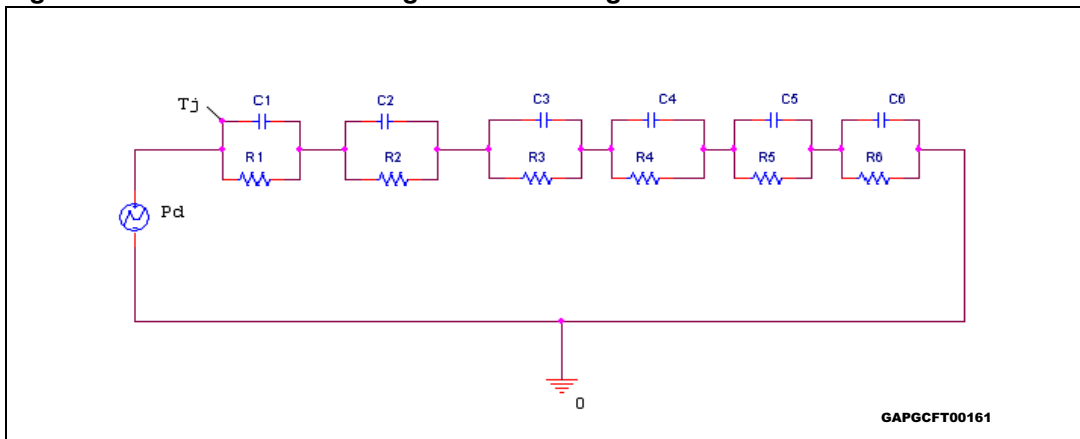

Table 10. SO-20 thermal parameter

Area/island (cm ²)	Footprint	2
R1 (°C/W)	4.21	
R2 (°C/W)	2.11	
R3 (°C/W)	2.2	
R4 (°C/W)	10	
R5 (°C/W)	15	
R6 (°C/W)	35	18
C1 (W.s/°C)	0.00029	
C2 (W.s/°C)	0.0024	
C3 (W.s/°C)	0.015	
C4 (W.s/°C)	0.15	
C5 (W.s/°C)	1.5	
C6 (W.s/°C)	4	7

5 Package and packing information

5.1 ECOPACK® packages

In order to meet environmental requirements, ST offers these devices in ECOPACK® packages. These packages have a Lead-free second-level interconnect. The category of Second-Level Interconnect is marked on the package and on the inner box label, in compliance with JEDEC Standard JESD97. The maximum ratings related to soldering conditions are also marked on the inner box label.

ECOPACK is an ST trademark. ECOPACK specifications are available at: www.st.com.

5.2 SO-8 package information

Figure 36. SO-8 package dimensions

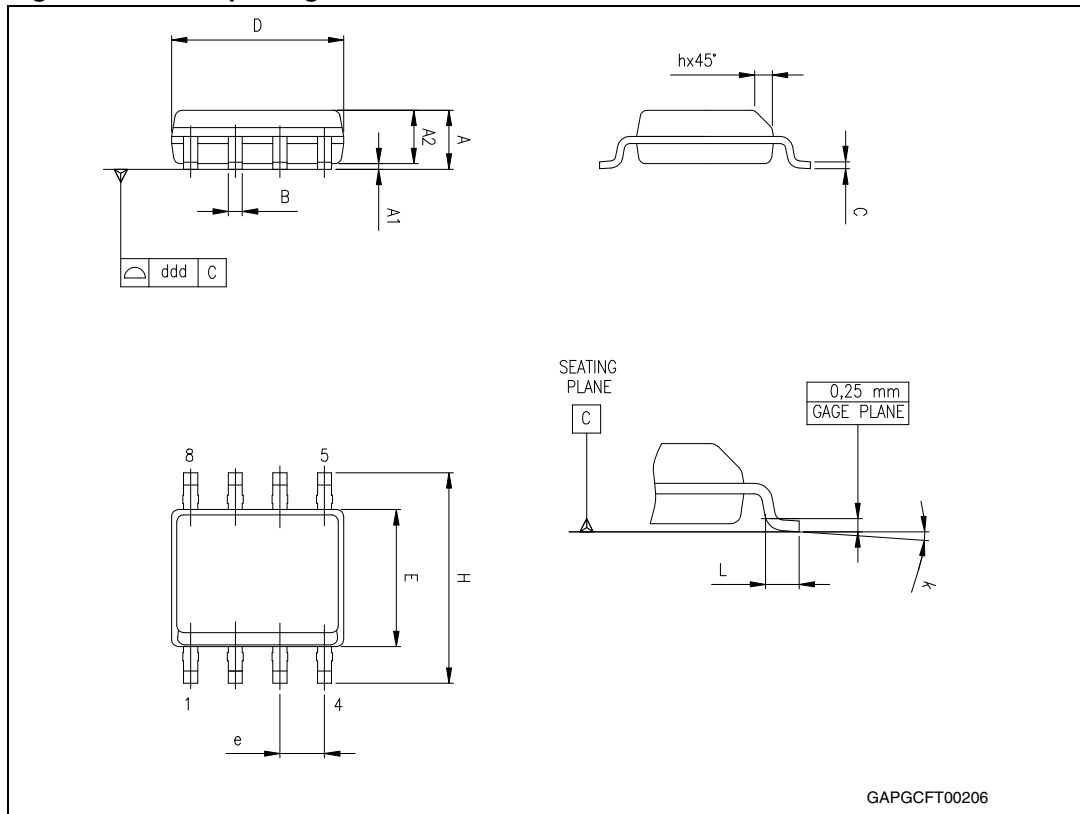

Table 11. SO-8 mechanical data

Symbol	Millimeters		
	Min.	Typ.	Max.
A			1.75
A1	0.10		0.25
A2	1.25		
b	0.28		0.48
c	0.17		0.23
D ⁽¹⁾	4.80	4.90	5.00
E	5.80	6.00	6.20
E1 ⁽²⁾	3.80	3.90	4.00
e		1.27	
h	0.25		0.50
L	0.40		1.27
L1		1.04	
k	0°		8°
ccc			0.10

1. Dimensions D does not include mold flash, protrusions or gate burrs. Mold flash, protrusions or gate burrs shall not exceed 0.15mm in total (both side).
2. Dimension "E1" does not include interlead flash or protrusions. Interlead flash or protrusions shall not exceed 0.25mm per side.

5.3 SO-20 package information

Figure 37. SO-20 package dimensions

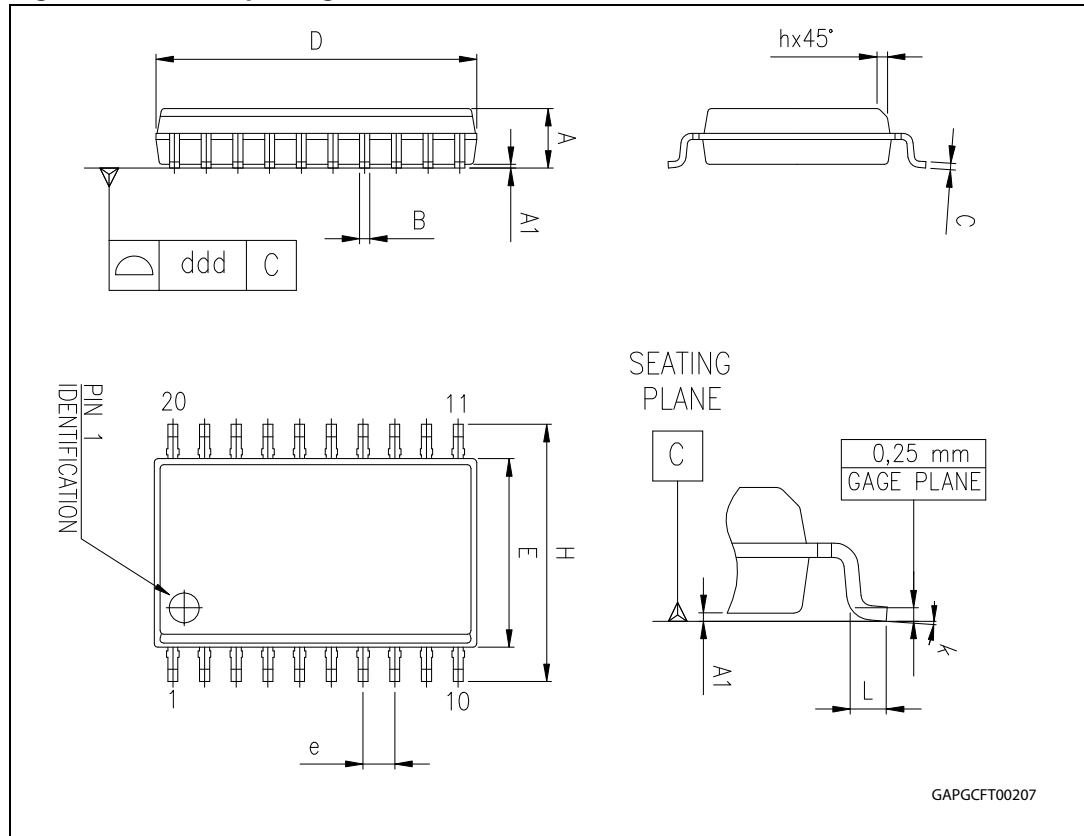

Table 12. SO-20 mechanical data

Symbol	Millimeters		
	Min.	Typ.	Max.
A	2.35		2.65
A1	0.10		0.30
B	0.33		0.51
C	0.23		0.32
D ⁽¹⁾	12.60		13.00
E	7.40		7.60
e		1.27	
H	10.0		10.65
h	0.25		0.75
L	0.40		1.27

Table 12. SO-20 mechanical data (continued)

Symbol	Millimeters		
	Min.	Typ.	Max.
k	0°		8°
ddd			0.10

1. "D" dimension does not include mold flash, protusions or gate burrs. Mold flash, protusions or gate burrs shall not exceed 0.15mm per side.

5.4 SO-8 packing information

Figure 38. SO-8 tube shipment (no suffix)

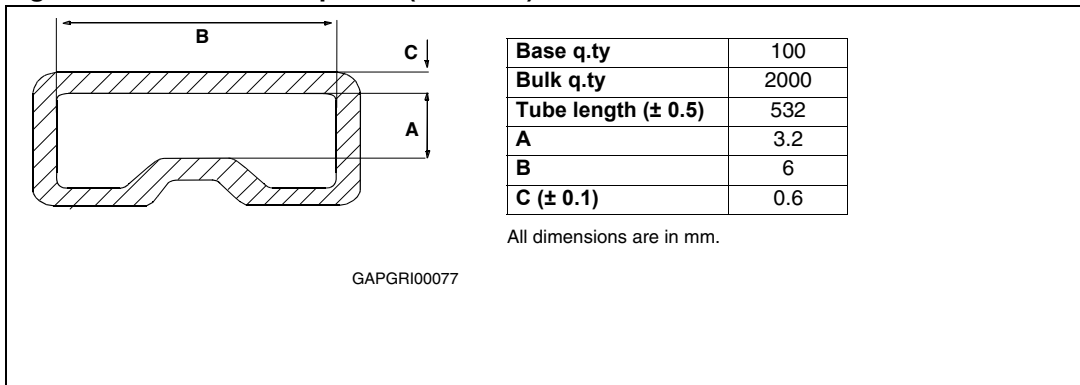
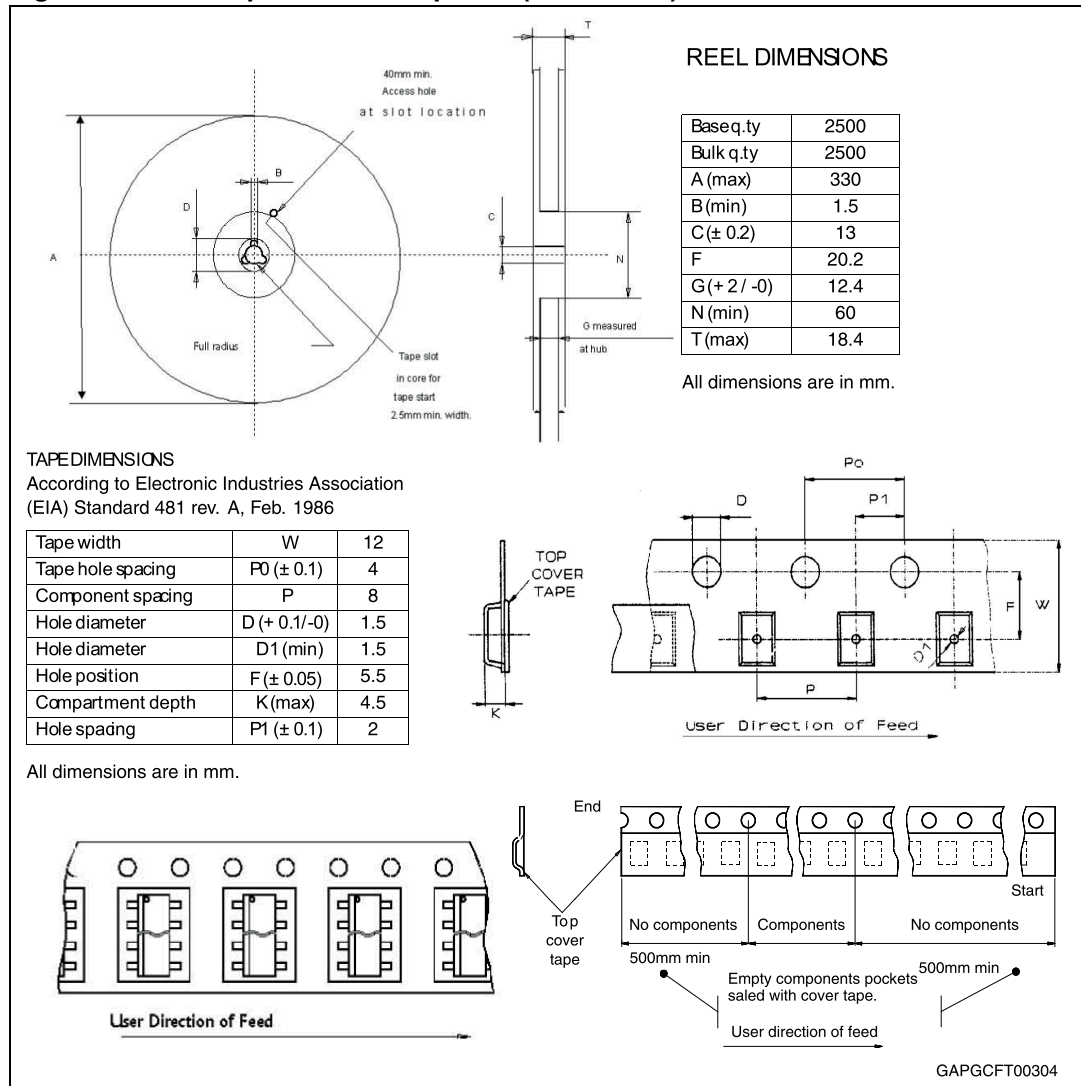

Figure 39. SO-8 tape and reel shipment (suffix "TR")



5.5 SO-20 packing information

Figure 40. SO-20 tube shipment (no suffix)

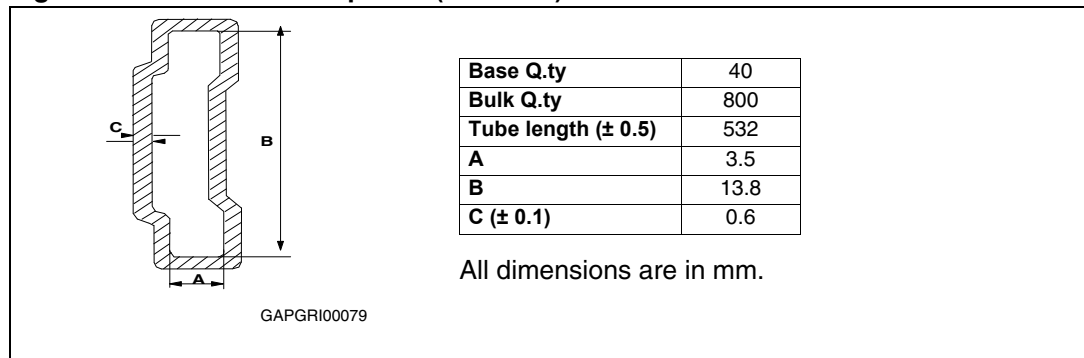
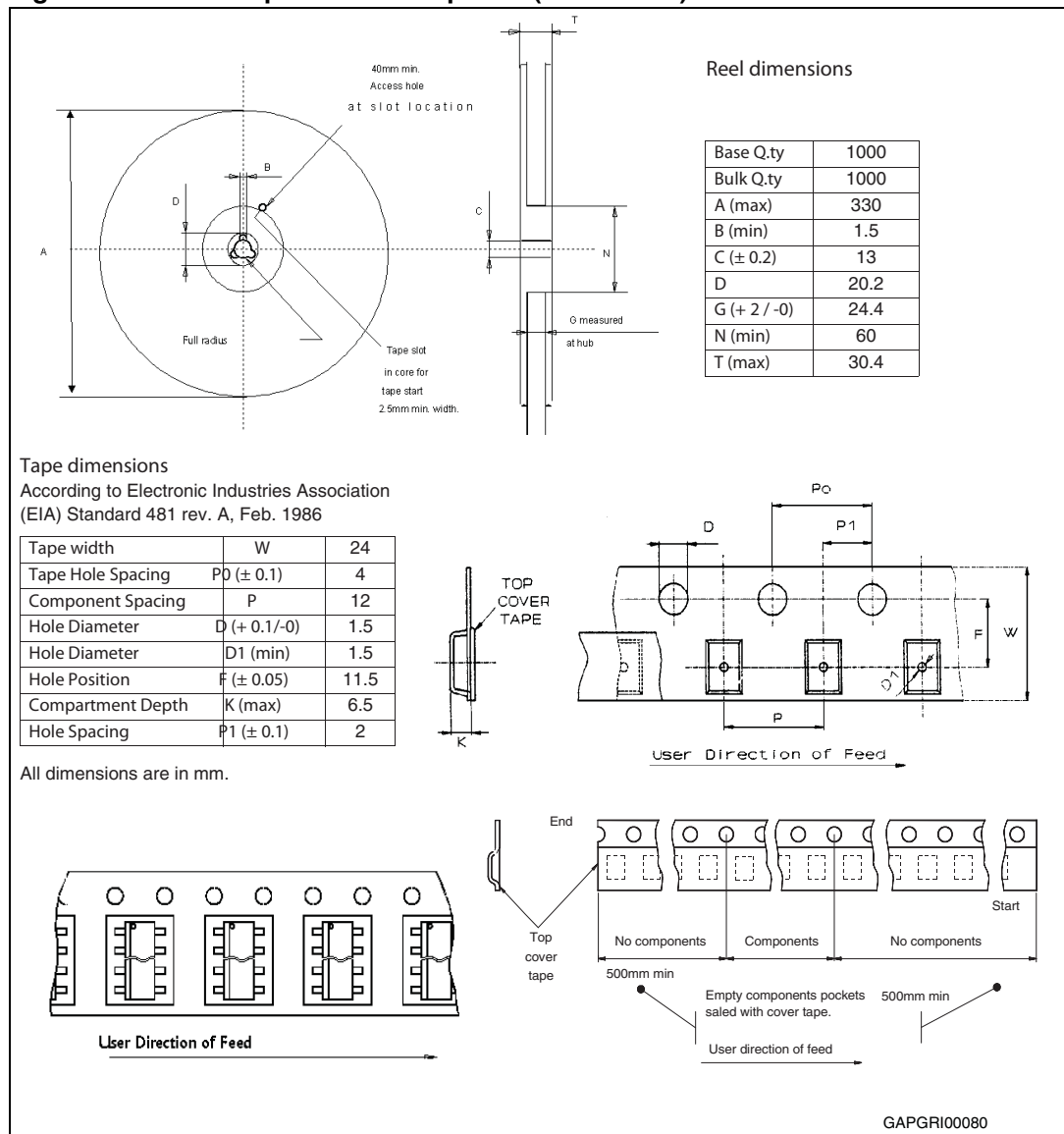

Figure 41. SO-20 tape and reel shipment (suffix “TR”)



6 Revision history

Table 13. Document revision history

Date	Revision	Changes
01-Jun-2007	1	Initial release
30-Aug-2007	2	Added features table. Added list of tables and figures. Updated Section 2.3: Electrical characteristics . Added Section 4: Package and PCB thermal data . Added SO-8 packing information and SO-20 packing information .
13-Feb-2008	3	Update Section 2.3: Electrical characteristics .
04-Jun-2008	4	Document restructured. Changed Figure 1: Block diagram . Updated features table on cover page: changed quiescent current value from 80 to 75 μ A. Updated Table 5: General : – changed I_{short} typical value from 250 to 280 mA – changed I_{qn_50} typical value from 550 to 500 μ A – changed $I_{q_1_we}$ typical value from 130 to 93 μ A – changed $I_{q_1_wd}$ typical value from 80 to 75 μ A. Updated Table 7: Watchdog : – changed V_{wlth} values in V_{o_ref} percentages – changed V_{whth} values in V_{o_ref} percentages. Added Figure 24: L4988 application schematic . Added Section 2.4: Electrical characteristics curves . Added Section 2.5: Test circuit and waveforms plot .
05-Apr-2012	5	Update Table 3: Absolute maximum ratings .
20-Sep-2013	6	Updated disclaimer.

Please Read Carefully:

Information in this document is provided solely in connection with ST products. STMicroelectronics NV and its subsidiaries ("ST") reserve the right to make changes, corrections, modifications or improvements, to this document, and the products and services described herein at any time, without notice.

All ST products are sold pursuant to ST's terms and conditions of sale.

Purchasers are solely responsible for the choice, selection and use of the ST products and services described herein, and ST assumes no liability whatsoever relating to the choice, selection or use of the ST products and services described herein.

No license, express or implied, by estoppel or otherwise, to any intellectual property rights is granted under this document. If any part of this document refers to any third party products or services it shall not be deemed a license grant by ST for the use of such third party products or services, or any intellectual property contained therein or considered as a warranty covering the use in any manner whatsoever of such third party products or services or any intellectual property contained therein.

UNLESS OTHERWISE SET FORTH IN ST'S TERMS AND CONDITIONS OF SALE ST DISCLAIMS ANY EXPRESS OR IMPLIED WARRANTY WITH RESPECT TO THE USE AND/OR SALE OF ST PRODUCTS INCLUDING WITHOUT LIMITATION IMPLIED WARRANTIES OF MERCHANTABILITY, FITNESS FOR A PARTICULAR PURPOSE (AND THEIR EQUIVALENTS UNDER THE LAWS OF ANY JURISDICTION), OR INFRINGEMENT OF ANY PATENT, COPYRIGHT OR OTHER INTELLECTUAL PROPERTY RIGHT.

ST PRODUCTS ARE NOT DESIGNED OR AUTHORIZED FOR USE IN: (A) SAFETY CRITICAL APPLICATIONS SUCH AS LIFE SUPPORTING, ACTIVE IMPLANTED DEVICES OR SYSTEMS WITH PRODUCT FUNCTIONAL SAFETY REQUIREMENTS; (B) AERONAUTIC APPLICATIONS; (C) AUTOMOTIVE APPLICATIONS OR ENVIRONMENTS, AND/OR (D) AEROSPACE APPLICATIONS OR ENVIRONMENTS. WHERE ST PRODUCTS ARE NOT DESIGNED FOR SUCH USE, THE PURCHASER SHALL USE PRODUCTS AT PURCHASER'S SOLE RISK, EVEN IF ST HAS BEEN INFORMED IN WRITING OF SUCH USAGE, UNLESS A PRODUCT IS EXPRESSLY DESIGNATED BY ST AS BEING INTENDED FOR "AUTOMOTIVE, AUTOMOTIVE SAFETY OR MEDICAL" INDUSTRY DOMAINS ACCORDING TO ST PRODUCT DESIGN SPECIFICATIONS. PRODUCTS FORMALLY ESCC, QML OR JAN QUALIFIED ARE DEEMED SUITABLE FOR USE IN AEROSPACE BY THE CORRESPONDING GOVERNMENTAL AGENCY.

Resale of ST products with provisions different from the statements and/or technical features set forth in this document shall immediately void any warranty granted by ST for the ST product or service described herein and shall not create or extend in any manner whatsoever, any liability of ST.

ST and the ST logo are trademarks or registered trademarks of ST in various countries.

Information in this document supersedes and replaces all information previously supplied.

The ST logo is a registered trademark of STMicroelectronics. All other names are the property of their respective owners.

© 2013 STMicroelectronics - All rights reserved

STMicroelectronics group of companies

Australia - Belgium - Brazil - Canada - China - Czech Republic - Finland - France - Germany - Hong Kong - India - Israel - Italy - Japan - Malaysia - Malta - Morocco - Philippines - Singapore - Spain - Sweden - Switzerland - United Kingdom - United States of America

www.st.com