

# L4949, NCV4949

## 100 mA, 5.0 V, Low Dropout Voltage Regulator with Power-On Reset

The L4949 is a monolithic integrated 5.0 V voltage regulator with a very low dropout and additional functions such as power-on reset and input voltage sense.

It is designed for supplying the micro-computer controlled systems especially in automotive applications.

### Features

- Operating DC Supply Voltage Range 5.0 V to 28 V
- Transient Supply Voltage Up to 40 V
- Extremely Low Quiescent Current in Standby Mode
- High Precision Standby Output Voltage 5.0 V  $\pm$ 1%
- Output Current Capability Up to 100 mA
- Very Low Dropout Voltage Less Than 0.4 V
- Reset Circuit Sensing The Output Voltage
- Programmable Reset Pulse Delay With External Capacitor
- Voltage Sense Comparator
- Thermal Shutdown and Short Circuit Protections
- NCV Prefix for Automotive and Other Applications Requiring Site and Control Changes
- Pb-Free Packages are Available

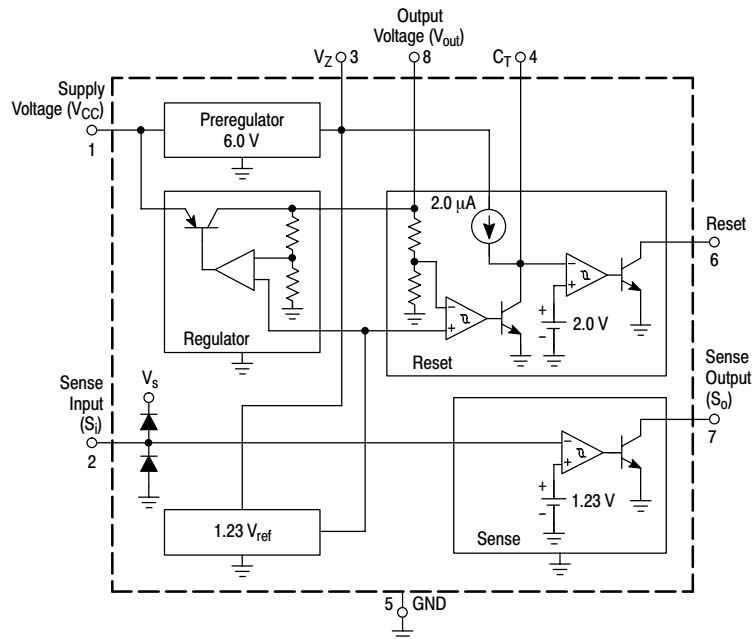

Figure 1. Representative Block Diagram



ON Semiconductor®

<http://onsemi.com>

### MARKING DIAGRAMS

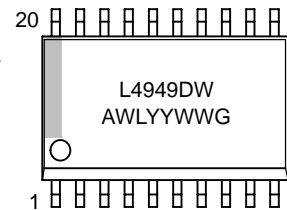
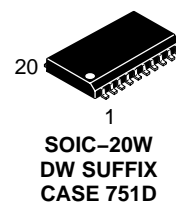
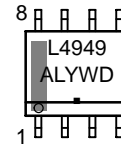
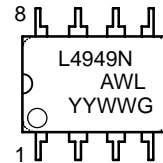
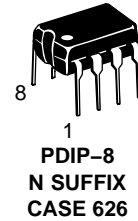

A = Assembly Location  
 WL, L = Wafer Lot  
 YY, Y = Year  
 WW, W = Work Week  
 G or ■ = Pb-Free Device

### PIN CONNECTIONS

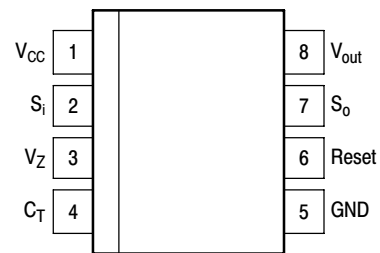

(Top View)

### ORDERING INFORMATION

See detailed ordering and shipping information in the package dimensions section on page 8 of this data sheet.

# L4949, NCV4949

## ABSOLUTE MAXIMUM RATINGS

Rating	Symbol	Value	Unit
DC Operating Supply Voltage	$V_{CC}$	28	V
Transient Supply Voltage ( $t < 1.0$ s)	$V_{CC\ TR}$	40	V
Output Current	$I_{out}$	Internally Limited	–
Output Voltage	$V_{out}$	20	V
Sense Input Current	$I_{SI}$	$\pm 1.0$	mA
Sense Input Voltage	$V_{SI}$	$V_{CC}$	–
Output Voltages Reset Output Sense Output	$V_{Reset}$ $V_{SO}$	20 20	V
Output Currents Reset Output Sense Output	$I_{Reset}$ $I_{SO}$	5.0 5.0	mA
Preregulator Output Voltage	$V_Z$	7.0	V
Preregulator Output Current	$I_Z$	5.0	mA
ESD Protection at any pin Human Body Model Machine Model	– –	2000 400	V
Thermal Resistance, Junction-to-Air P Suffix, DIP–8 Plastic Package, Case 626 D Suffix, SOIC–8 Plastic Package, Case 751 D Suffix, SOIC–20 Plastic Package, Case 751D	$R_{\theta JA}$	100 200 80	$^{\circ}C/W$
Operating Junction Temperature Range	$T_J$	–40 to +150	$^{\circ}C$
Storage Temperature Range	$T_{stg}$	–65 to +150	$^{\circ}C$

Stresses exceeding Maximum Ratings may damage the device. Maximum Ratings are stress ratings only. Functional operation above the Recommended Operating Conditions is not implied. Extended exposure to stresses above the Recommended Operating Conditions may affect device reliability.

## ELECTRICAL CHARACTERISTICS ( $V_{CC} = 14$ V, $-40^{\circ}C < T_A < 125^{\circ}C$ , unless otherwise specified.)

Characteristic	Symbol	Min	Typ	Max	Unit
Output Voltage ( $T_A = 25^{\circ}C$ , $I_{out} = 1.0$ mA)	$V_{out}$	4.95	5.0	5.05	V
Output Voltage ( $6.0$ V $< V_{CC} < 28$ V, $1.0$ mA $< I_{out} < 50$ mA)	$V_{out}$	4.9	5.0	5.1	V
Output Voltage ( $V_{CC} = 35$ V, $t < 1.0$ s, $1.0$ mA $< I_{out} < 50$ mA)	$V_{out}$	4.9	5.0	5.1	V
Dropout Voltage $I_{out} = 10$ mA $I_{out} = 50$ mA $I_{out} = 100$ mA	$V_{drop}$	– – –	0.1 0.2 0.3	0.25 0.40 0.50	V
Input to Output Voltage Difference in Undervoltage Condition ( $V_{CC} = 4.0$ V, $I_{out} = 35$ mA)	$V_{IO}$	–	0.2	0.4	V
Line Regulation ( $6.0$ V $< V_{CC} < 28$ V, $I_{out} = 1.0$ mA)	$Reg_{line}$	–	1.0	20	mV
Load Regulation ( $1.0$ mA $< I_{out} < 100$ mA)	$Reg_{load}$	–	8.0	30	mV
Current Limit $V_{out} = 4.5$ V $V_{out} = 0$ V	$I_{Lim}$	105 –	200 100	400 –	mA
Quiescent Current ( $I_{out} = 0.3$ mA, $T_A < 100^{\circ}C$ )	$I_{QSE}$	–	150	260	$\mu A$
Quiescent Current ( $I_{out} = 100$ mA)	$I_Q$	–	–	5.0	mA

# L4949, NCV4949

## ELECTRICAL CHARACTERISTICS (continued) ( $V_{CC} = 14\text{ V}$ , $-40^{\circ}\text{C} < T_A < 125^{\circ}\text{C}$ , unless otherwise specified.)

Characteristic	Symbol	Min	Typ	Max	Unit
<b>RESET</b>					
Reset Threshold Voltage	$V_{ResTh}$	-	$V_{out} - 0.5$	-	V
Reset Threshold Hysteresis @ $T_A = 25^{\circ}\text{C}$ @ $T_A = -40$ to $+125^{\circ}\text{C}$	$V_{ResTh,hys}$	50 50	100 -	200 300	mV
Reset Pulse Delay ( $C_T = 100\text{ nF}$ , $t_R \geq 100\text{ }\mu\text{s}$ )	$t_{ResD}$	55	100	180	ms
Reset Reaction Time ( $C_T = 100\text{ nF}$ )	$t_{ResR}$	-	5.0	30	$\mu\text{s}$
Reset Output Low Voltage ( $R_{Reset} = 10\text{ k}\Omega$ to $V_{out}$ , $V_{CC} \geq 3.0\text{ V}$ )	$V_{ResL}$	-	-	0.4	V
Reset Output High Leakage Current ( $V_{Reset} = 5.0\text{ V}$ )	$I_{ResH}$	-	-	1.0	$\mu\text{A}$
Delay Comparator Threshold	$V_{CTTh}$	-	2.0	-	V
Delay Comparator Threshold Hysteresis	$V_{CTTh,hys}$	-	100	-	mV
<b>SENSE</b>					
Sense Low Threshold ( $V_{SI}$ Decreasing = $1.5\text{ V}$ to $1.0\text{ V}$ )	$V_{SOTh}$	1.16	1.23	1.35	V
Sense Threshold Hysteresis	$V_{SOTh,hys}$	20	100	200	mV
Sense Output Low Voltage ( $V_{SI} \leq 1.16\text{ V}$ , $V_{CC} \geq 3.0\text{ V}$ , $R_{SO} = 10\text{ k}\Omega$ to $V_{out}$ )	$V_{SOL}$	-	-	0.4	V
Sense Output Leakage ( $V_{SO} = 5.0\text{ V}$ , $V_{SI} \geq 1.5\text{ V}$ )	$I_{SOH}$	-	-	1.0	$\mu\text{A}$
Sense Input Current	$I_{SI}$	-1.0	0.1	1.0	$\mu\text{A}$
<b>PREREGULATOR</b>					
Preregulator Output Voltage ( $I_Z = 10\text{ }\mu\text{A}$ )	$V_Z$	-	6.3	-	V

## PIN FUNCTION DESCRIPTION

Pin SOIC-8, PDIP-8	Pin SOIC-20W	Symbol	Description
1	19	$V_{CC}$	Supply Voltage
2	20	$S_i$	Input of Sense Comparator
3	1	$V_Z$	Output of Preregulator
4	2	$C_T$	Reset Delay Capacitor
5	4 - 7, 14 - 17	GND	Ground
6	10	Reset	Output of Reset Comparator
7	11	$S_o$	Output of Sense Comparator
8	12	$V_{out}$	Main Regulator Output
-	3, 8, 9, 13, 18	NC	No Connect

TYPICAL CHARACTERIZATION CURVES

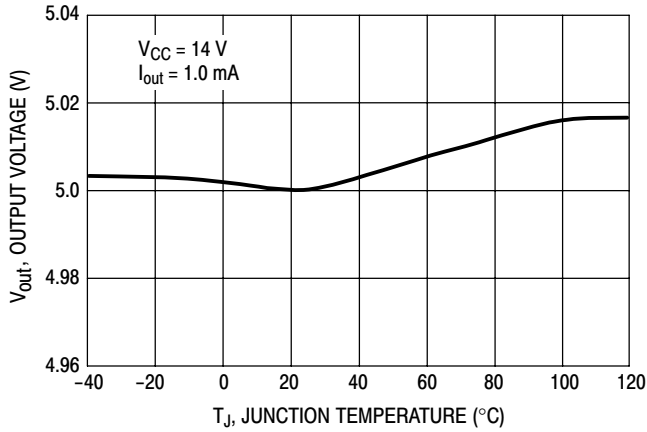

Figure 2. Output Voltage versus Junction Temperature

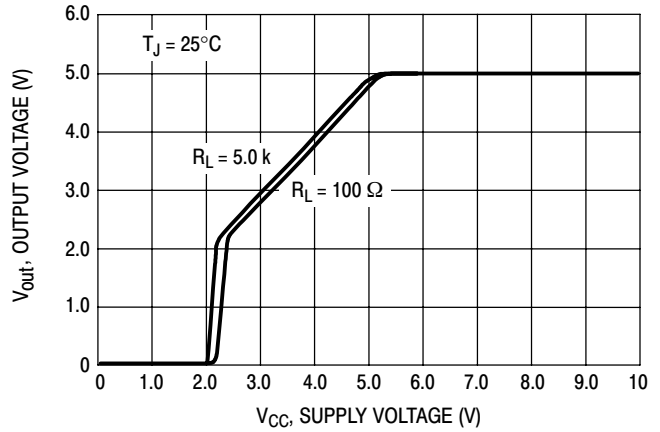

Figure 3. Output Voltage versus Supply Voltage

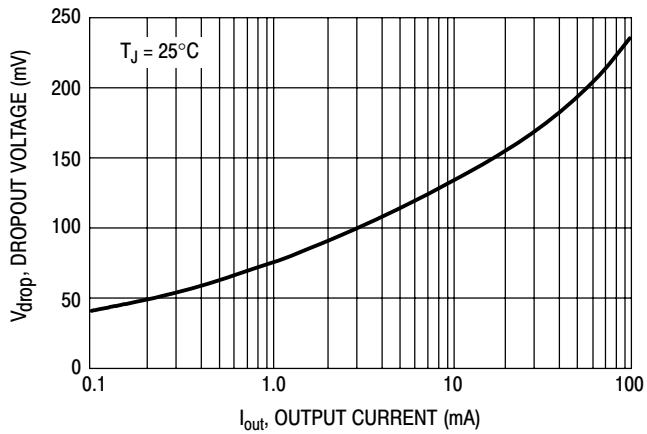

Figure 4. Dropout Voltage versus Output Current

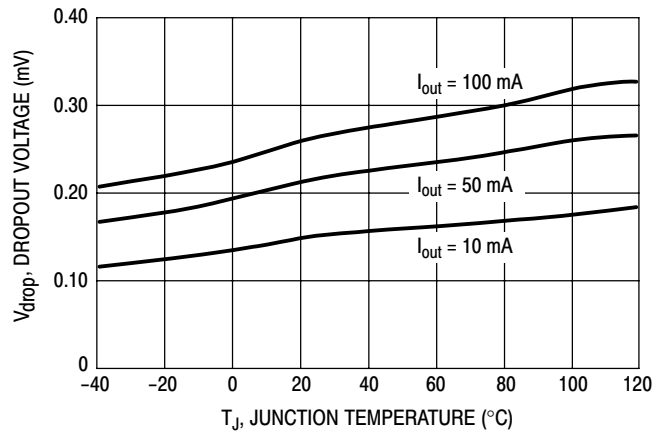

Figure 5. Dropout Voltage versus Junction Temperature

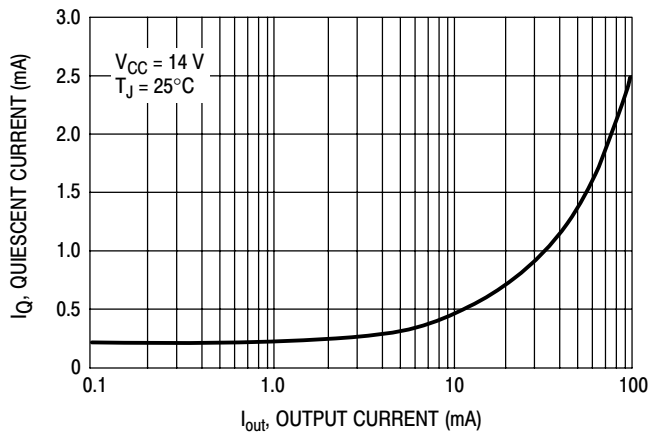

Figure 6. Quiescent Current versus Output Current

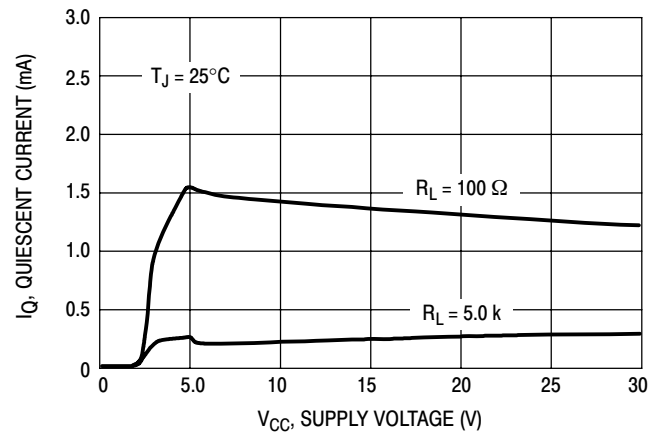

Figure 7. Quiescent Current versus Supply Voltage

TYPICAL CHARACTERIZATION CURVES (continued)

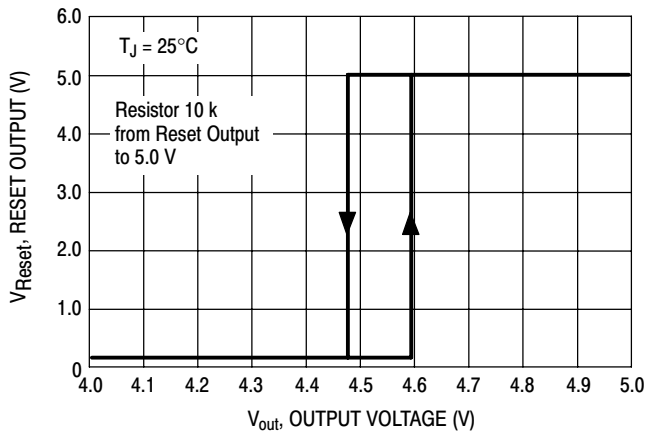

Figure 8. Reset Output versus Regulator Output Voltage

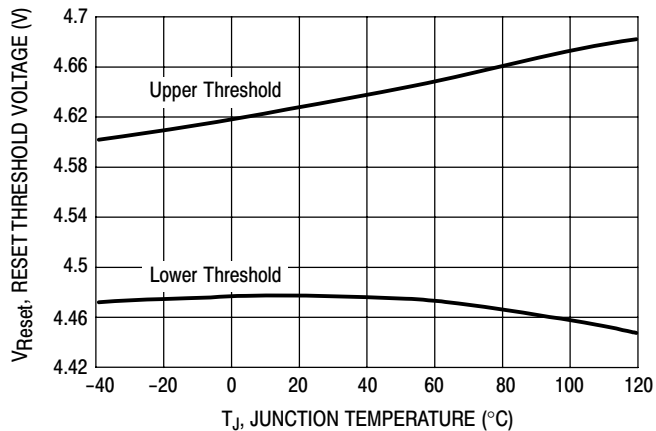

Figure 9. Reset Thresholds versus Junction Temperature

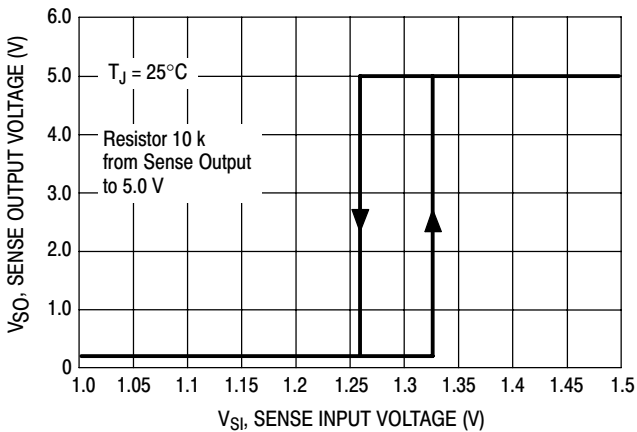

Figure 10. Sense Output versus Sense Input Voltage

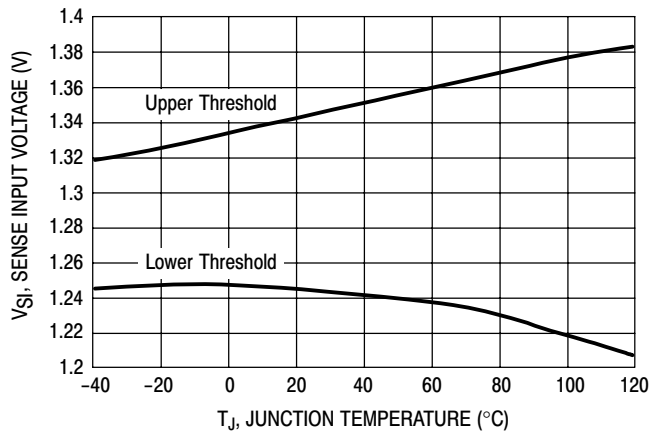

Figure 11. Sense Thresholds versus Junction Temperature

APPLICATION INFORMATION

Supply Voltage Transient

High supply voltage transients can cause a reset output signal perturbation. For supply voltages greater than 8.0 V the circuit shows a high immunity of the reset output against supply transients of more than 100 V/ $\mu$ s. For supply voltages

less than 8.0 V supply transients of more than 0.4 V/ $\mu$ s can cause a reset signal perturbation. To improve the transient behavior for supply voltages less than 8.0 V a capacitor at Pin 3 can be used. A capacitor at Pin 3 ( $C_3 \leq 1.0 \mu$ F) reduces also the output noise.

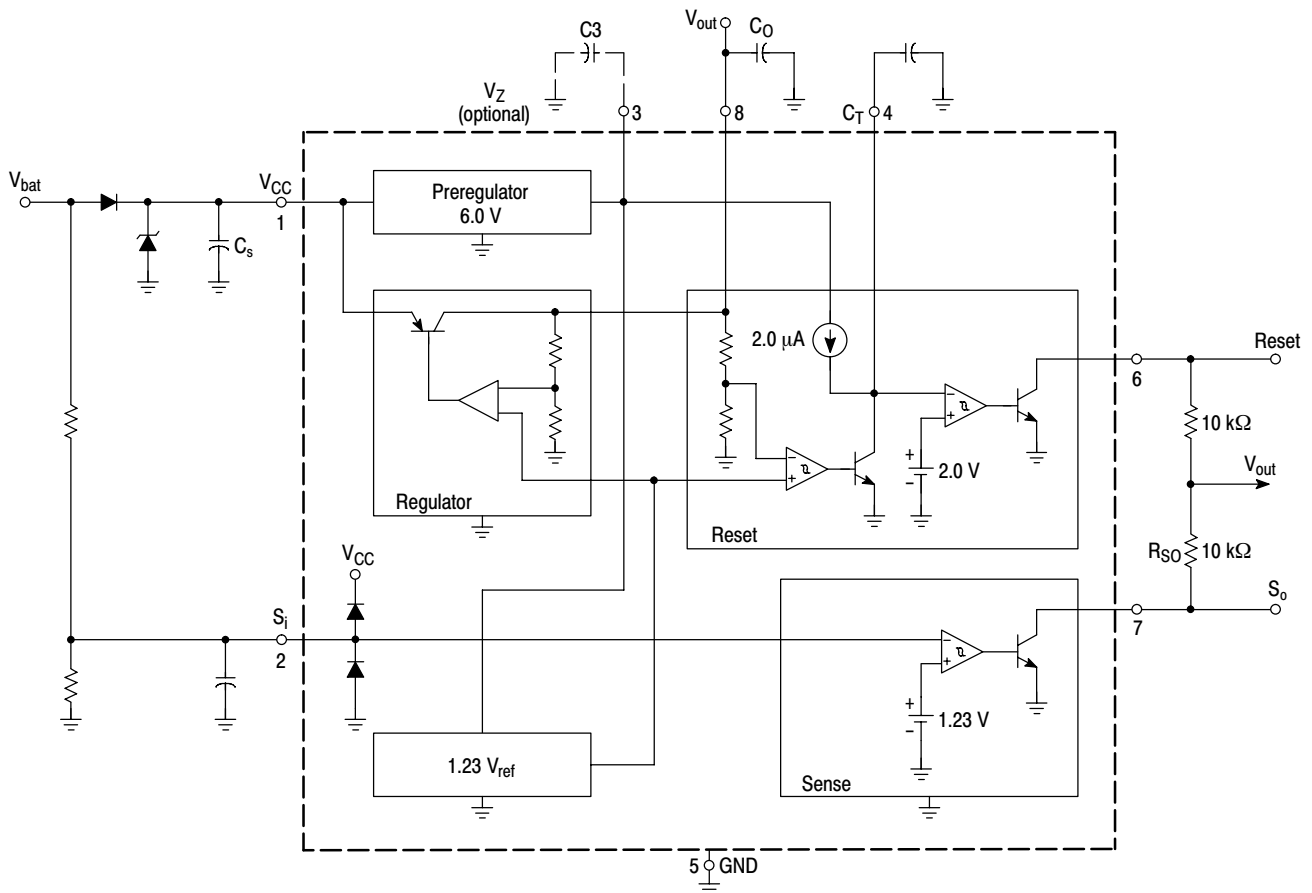

- NOTE: 1. For stability:  $C_s \geq 1.0 \mu$ F,  $C_o \geq 4.7 \mu$ F,  $ESR < 10 \Omega$  at 10 kHz  
 2. Recommended for application:  $C_s = C_o = 10 \mu$ F

Figure 12. Application Schematic

OPERATING DESCRIPTION

The L4949 is a monolithic integrated low dropout voltage regulator. Several outstanding features and auxiliary functions are implemented to meet the requirements of supplying microprocessor systems in automotive applications. Nevertheless, it is suitable also in other applications where the present functions are required. The modular approach of this device allows the use of other features and functions independently when required.

**Voltage Regulator**

The voltage regulator uses an isolated Collector Vertical PNP transistor as a regulating element. With this structure, very low dropout voltage at currents up to 100 mA is obtained. The dropout operation of the standby regulator is maintained down to 3.0 V input supply voltage. The output voltage is regulated up to the transient input supply voltage of 35 V. With this feature no functional interruption due to overvoltage pulses is generated.

The typical curve showing the standby output voltage as a function of the input supply voltage is shown in Figure 14.

The current consumption of the device (quiescent current) is less than 200  $\mu$ A.

To reduce the quiescent current peak in the undervoltage region and to improve the transient response in this region, the dropout voltage is controlled. The quiescent current as a function of the supply input voltage is shown in Figure 15.

**Short Circuit Protection:**

The maximum output current is internally limited. In case of short circuit, the output current is foldback current limited as described in Figure 13.

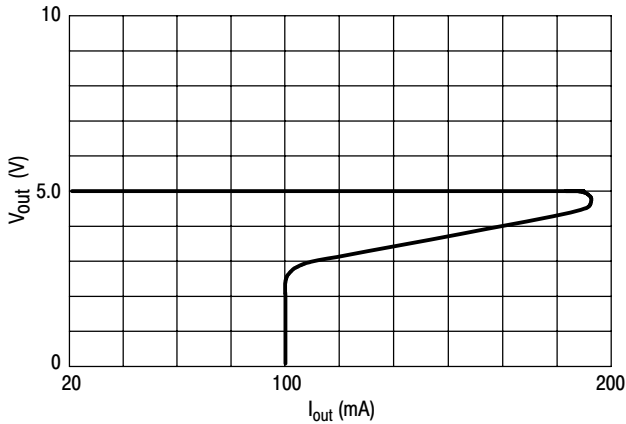

Figure 13. Foldback Characteristic of  $V_{out}$

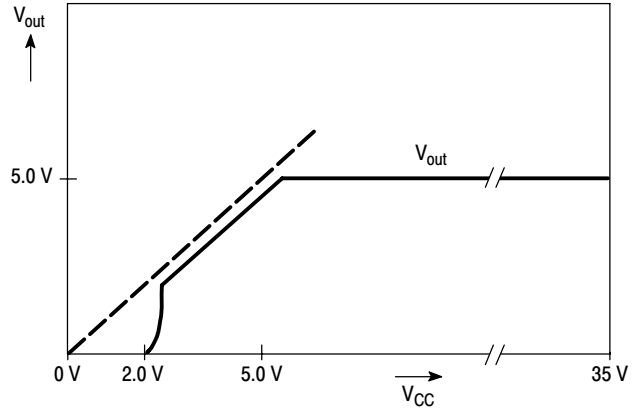

Figure 14. Output Voltage versus Supply Voltage

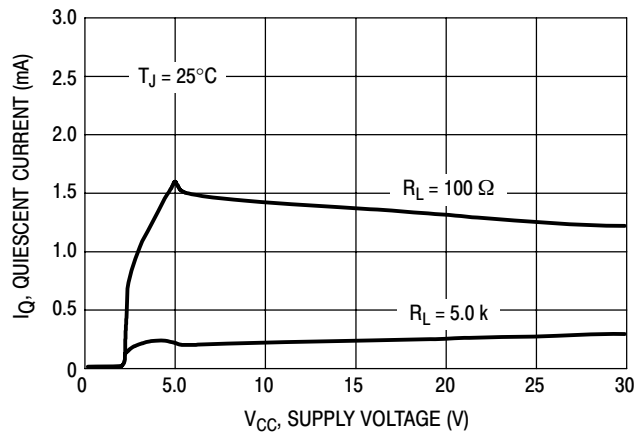

Figure 15. Quiescent Current versus Supply Voltage

**Preregulator**

To improve the transient immunity a preregulator stabilizes the internal supply voltage to 6.0 V. This internal voltage is present at Pin 3 ( $V_Z$ ). This voltage should not be used as an output because the output capability is very small ( $\leq 100 \mu$ A).

This output may be used as an option when better transient behavior for supply voltages less than 8.0 V is required. In this case a capacitor (100 nF – 1.0  $\mu$ F) must be connected between Pin 3 and GND. If this feature is not used Pin 3 must be left open.

# L4949, NCV4949

## Reset Circuit

The block circuit diagram of the reset circuit is shown in Figure 16.

The reset circuit supervises the output voltage. The reset threshold of 4.5 V is defined with the internal reference voltage and standby output divider.

The reset pulse delay time  $t_{RD}$ , is defined with the charge time of an external capacitor  $C_T$ :

$$t_{RD} = \frac{C_T \times 2.0 \text{ V}}{2.0 \mu\text{A}}$$

The reaction time of the reset circuit originates from the discharge time limitation of the reset capacitor  $C_T$  and is proportional to the value of  $C_T$ . The reaction time of the reset circuit increases the noise immunity.

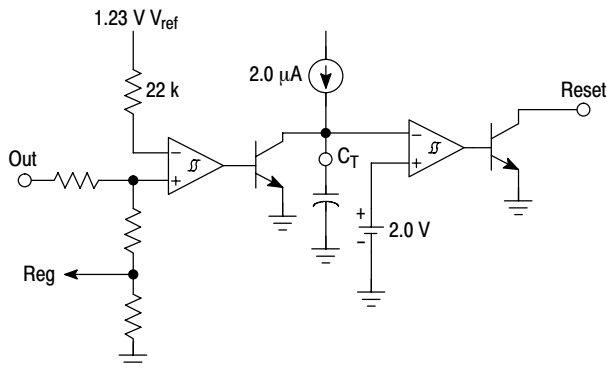

Figure 16. Reset Circuit

Standby output voltage drops below the reset threshold only a bit longer than the reaction time results in a shorter reset delay time.

The nominal reset delay time will be generated for standby output voltage drops longer than approximately 50 μs. The typical reset output waveforms are shown in Figure 17.

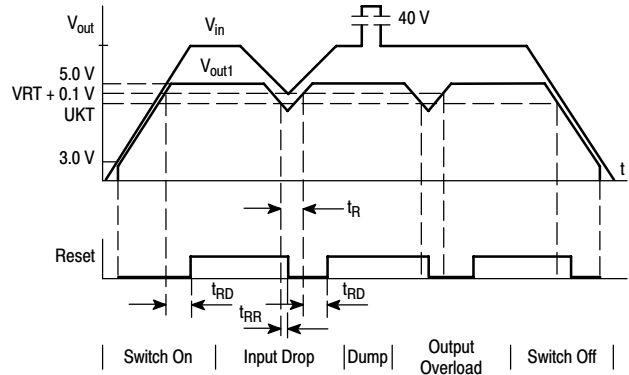

Figure 17. Typical Reset Output Waveforms

## Sense Comparator

The sense comparator compares an input signal with an internal voltage reference of typical 1.23 V. The use of an external voltage divider makes this comparator very flexible in the application.

It can be used to supervise the input voltage either before or after the protection diode and to give additional information to the microprocessor like low voltage warnings.

## ORDERING INFORMATION

Device	Operating Temperature Range	Package	Shipping†
L4949N	$T_J = -40^\circ\text{C}$ to $+125^\circ\text{C}$	PDIP-8	50 Units / Rail
L4949NG		PDIP-8 (Pb-Free)	50 Units / Rail
L4949D		SOIC-8	98 Units / Rail
L4949DG		SOIC-8 (Pb-Free)	98 Units / Rail
L4949DR2		SOIC-8	2500 Units / Tape & Reel
L4949DR2G		SOIC-8 (Pb-Free)	2500 Units / Tape & Reel
NCV4949DG*		SOIC-8 (Pb-Free)	98 Units / Rail
NCV4949DR2*		SOIC-8	2500 Units / Tape & Reel
NCV4949DR2G*		SOIC-8 (Pb-Free)	2500 Units / Tape & Reel
NCV4949DWR2*		SOIC-20W	1000 Units / Tape & Reel
NCV4949DWR2G*		SOIC-20W (Pb-Free)	1000 Units / Tape & Reel

†For information on tape and reel specifications, including part orientation and tape sizes, please refer to our Tape and Reel Packaging Specifications Brochure, BRD8011/D.

\*NCV4949:  $T_{low} = -40^\circ\text{C}$ ,  $T_{high} = +125^\circ\text{C}$ . Guaranteed by design.

NCV prefix is for automotive and other applications requiring site and change control.



# L4949, NCV4949

## PACKAGE DIMENSIONS

### N SUFFIX PLASTIC PACKAGE CASE 626-05 ISSUE L

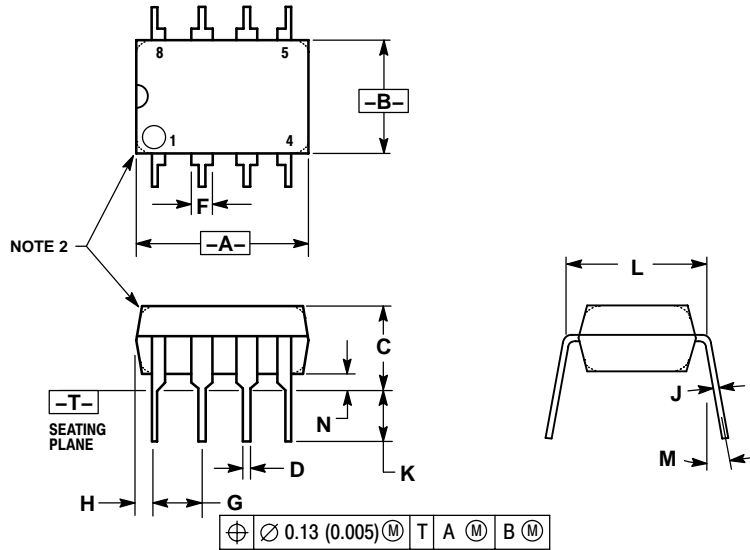

NOTES:

1. DIMENSION L TO CENTER OF LEAD WHEN FORMED PARALLEL.
2. PACKAGE CONTOUR OPTIONAL (ROUND OR SQUARE CORNERS).
3. DIMENSIONING AND TOLERANCING PER ANSI Y14.5M, 1982.

DIM	MILLIMETERS		INCHES	
	MIN	MAX	MIN	MAX
A	9.40	10.16	0.370	0.400
B	6.10	6.60	0.240	0.260
C	3.94	4.45	0.155	0.175
D	0.38	0.51	0.015	0.020
F	1.02	1.78	0.040	0.070
G	2.54 BSC		0.100 BSC	
H	0.76	1.27	0.030	0.050
J	0.20	0.30	0.008	0.012
K	2.92	3.43	0.115	0.135
L	7.62 BSC		0.300 BSC	
M	---	10°	---	10°
N	0.76	1.01	0.030	0.040

### SOIC-20 WB DW SUFFIX CASE 751D-05 ISSUE G

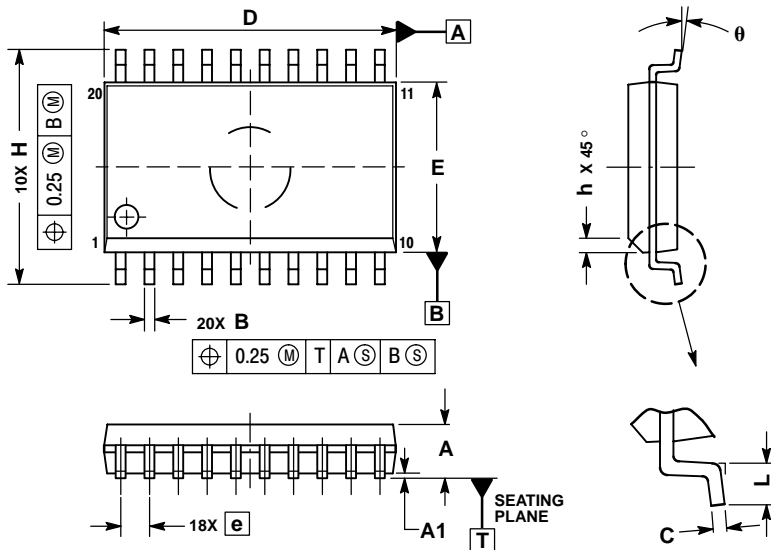

NOTES:

1. DIMENSIONS ARE IN MILLIMETERS.
2. INTERPRET DIMENSIONS AND TOLERANCES PER ASME Y14.5M, 1994.
3. DIMENSIONS D AND E DO NOT INCLUDE MOLD PROTRUSION.
4. MAXIMUM MOLD PROTRUSION 0.15 PER SIDE.
5. DIMENSION B DOES NOT INCLUDE DAMBAR PROTRUSION. ALLOWABLE PROTRUSION SHALL BE 0.13 TOTAL IN EXCESS OF B DIMENSION AT MAXIMUM MATERIAL CONDITION.

DIM	MILLIMETERS	
	MIN	MAX
A	2.35	2.65
A1	0.10	0.25
B	0.35	0.49
C	0.23	0.32
D	12.65	12.95
E	7.40	7.60
e	1.27 BSC	
H	10.05	10.55
h	0.25	0.75
L	0.50	0.90
θ	0°	7°

# L4949, NCV4949

## PACKAGE DIMENSIONS

### SOIC-8 D SUFFIX CASE 751-07 ISSUE AH

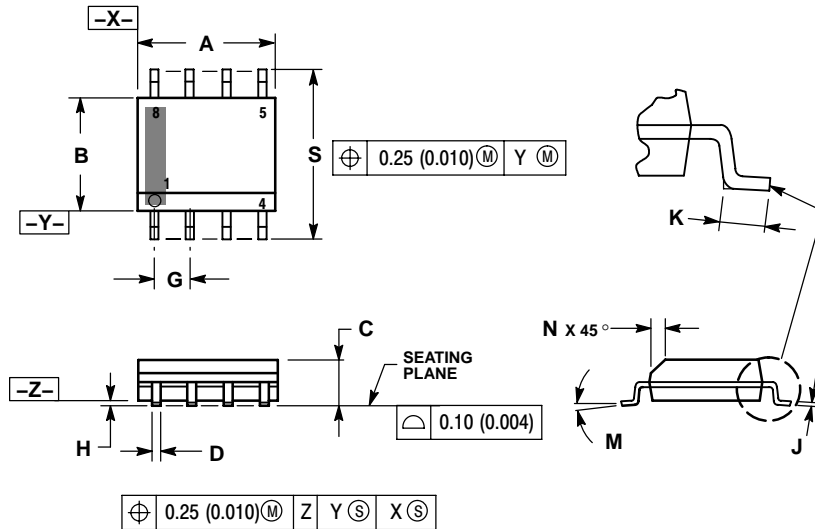

#### NOTES:

1. DIMENSIONING AND TOLERANCING PER ANSI Y14.5M, 1982.
2. CONTROLLING DIMENSION: MILLIMETER.
3. DIMENSION A AND B DO NOT INCLUDE MOLD PROTRUSION.
4. MAXIMUM MOLD PROTRUSION 0.15 (0.006) PER SIDE.
5. DIMENSION D DOES NOT INCLUDE DAMBAR PROTRUSION. ALLOWABLE DAMBAR PROTRUSION SHALL BE 0.127 (0.005) TOTAL IN EXCESS OF THE D DIMENSION AT MAXIMUM MATERIAL CONDITION.
6. 751-01 THRU 751-06 ARE OBSOLETE. NEW STANDARD IS 751-07.

DIM	MILLIMETERS		INCHES	
	MIN	MAX	MIN	MAX
A	4.80	5.00	0.189	0.197
B	3.80	4.00	0.150	0.157
C	1.35	1.75	0.053	0.069
D	0.33	0.51	0.013	0.020
G	1.27 BSC		0.050 BSC	
H	0.10	0.25	0.004	0.010
J	0.19	0.25	0.007	0.010
K	0.40	1.27	0.016	0.050
M	0°	8°	0°	8°
N	0.25	0.50	0.010	0.020
S	5.80	6.20	0.228	0.244

#### SOLDERING FOOTPRINT\*

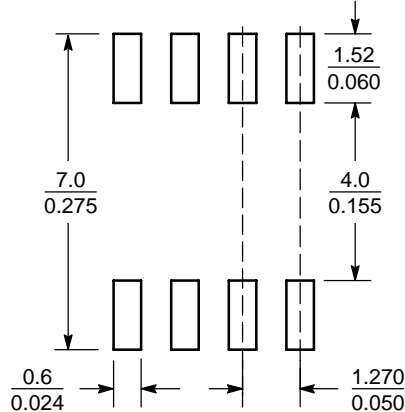

SCALE 6:1 ( $\frac{\text{mm}}{\text{inches}}$ )

\*For additional information on our Pb-Free strategy and soldering details, please download the ON Semiconductor Soldering and Mounting Techniques Reference Manual, SOLDERRM/D.

ON Semiconductor and are registered trademarks of Semiconductor Components Industries, LLC (SCILLC). SCILLC reserves the right to make changes without further notice to any products herein. SCILLC makes no warranty, representation or guarantee regarding the suitability of its products for any particular purpose, nor does SCILLC assume any liability arising out of the application or use of any product or circuit, and specifically disclaims any and all liability, including without limitation special, consequential or incidental damages. "Typical" parameters which may be provided in SCILLC data sheets and/or specifications can and do vary in different applications and actual performance may vary over time. All operating parameters, including "Typicals" must be validated for each customer application by customer's technical experts. SCILLC does not convey any license under its patent rights nor the rights of others. SCILLC products are not designed, intended, or authorized for use as components in systems intended for surgical implant into the body, or other applications intended to support or sustain life, or for any other application in which the failure of the SCILLC product could create a situation where personal injury or death may occur. Should Buyer purchase or use SCILLC products for any such unintended or unauthorized application, Buyer shall indemnify and hold SCILLC and its officers, employees, subsidiaries, affiliates, and distributors harmless against all claims, costs, damages, and expenses, and reasonable attorney fees arising out of, directly or indirectly, any claim of personal injury or death associated with such unintended or unauthorized use, even if such claim alleges that SCILLC was negligent regarding the design or manufacture of the part. SCILLC is an Equal Opportunity/Affirmative Action Employer. This literature is subject to all applicable copyright laws and is not for resale in any manner.

#### PUBLICATION ORDERING INFORMATION

**LITERATURE FULFILLMENT:**  
Literature Distribution Center for ON Semiconductor  
P.O. Box 5163, Denver, Colorado 80217 USA  
Phone: 303-675-2175 or 800-344-3860 Toll Free USA/Canada  
Fax: 303-675-2176 or 800-344-3867 Toll Free USA/Canada  
Email: orderlit@onsemi.com

**N. American Technical Support:** 800-282-9855 Toll Free USA/Canada  
**Europe, Middle East and Africa Technical Support:**  
Phone: 421 33 790 2910  
**Japan Customer Focus Center**  
Phone: 81-3-5773-3850

**ON Semiconductor Website:** [www.onsemi.com](http://www.onsemi.com)  
**Order Literature:** <http://www.onsemi.com/orderlit>

For additional information, please contact your local Sales Representative