



L3G4200D

MEMS motion sensor: three-axis digital output gyroscope

Features

- Three selectable full scales ($\pm 250/500/2000$ dps)
- I²C/SPI digital output interface
- 16 bit rate value data output
- Two digital output lines (interrupt and data ready)
- Integrated low and high pass filters with user selectable bandwidth
- Embedded self-test
- Wide supply voltage, 2.4 V to 3.6 V
- Low voltage compatible IOs, 1.8 V
- Embedded power-down and sleep mode
- High shock survivability
- Extended operating temperature range (-40 °C to +85 °C)
- ECOPACK[®] RoHS and “Green” compliant (see [Section 6](#))

Applications

- Gaming and virtual reality input devices
- Motion control with MMI (man-machine interface)
- GPS navigation systems
- Appliances and robotics

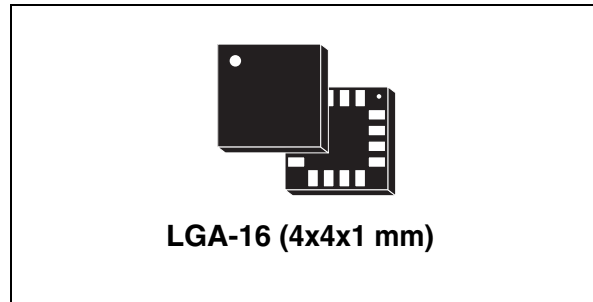

Description

The L3G4200D is a low-power three-axis gyroscope providing three different user selectable full scales ($\pm 250/\pm 500/\pm 2000$ dps).

It includes a sensing element and an IC interface able to provide the detected angular rate to the external world through a digital interface (I²C/SPI).

The sensing element is manufactured using specialized micromachining processes, while the IC interface is realized using a CMOS technology that allows designing a dedicated circuit which is trimmed to better match the sensing element characteristics.

The L3G4200D is available in a plastic land grid array (LGA) package and provides excellent temperature stability and high resolution over an extended operating temperature range (-40 °C to +85 °C).

Table 1. Device summary

Order code	Temperature range (°C)	Package	Packing
L3G4200D	-40 to + 85	LGA-16 (4x4x1)	Tray
L3G4200DTR			Tape and reel

Contents

- 1 Block diagram and pin description 5**
 - 1.1 Pin description 5

- 2 Mechanical and electrical specifications 8**
 - 2.1 Mechanical characteristics 8
 - 2.2 Electrical characteristics 9
 - 2.3 Communication interface characteristics 10
 - 2.3.1 SPI - serial peripheral interface 10
 - 2.3.2 I2C - Inter IC control interface 11

- 3 Absolute maximum ratings 12**
 - 3.1 Terminology 13
 - 3.1.1 Sensitivity 13
 - 3.1.2 Zero-rate level 13
 - 3.1.3 Self-test 13
 - 3.2 Soldering information 13

- 4 Digital main blocks 14**
 - 4.1 Block diagram 14

- 5 Digital interfaces 15**
 - 5.1 I2C serial interface 15
 - 5.1.1 I2C operation 16
 - 5.2 SPI bus interface 17
 - 5.2.1 SPI read 19
 - 5.2.2 SPI write 19
 - 5.2.3 SPI read in 3-wires mode 20

- 6 Package information 21**

- 7 Revision history 23**

List of tables

Table 1.	Device summary	1
Table 2.	Pin description	6
Table 3.	Filter values	7
Table 4.	Mechanical characteristics @ Vdd = 3.0 V, T = 25 °C unless otherwise noted	8
Table 5.	Electrical characteristics @ Vdd =3.0 V, T=25 °C unless otherwise noted.	9
Table 6.	SPI slave timing values.	10
Table 7.	I2C slave timing values.	11
Table 8.	Absolute maximum ratings	12
Table 9.	Serial interface pin description	15
Table 10.	I2C terminology.	15
Table 11.	SAD+Read/Write patterns	16
Table 12.	Transfer when Master is writing one byte to slave	16
Table 13.	Transfer when Master is writing multiple bytes to slave	17
Table 14.	Transfer when Master is receiving (reading) one byte of data from slave	17
Table 15.	Transfer when Master is receiving (reading) multiple bytes of data from slave	17
Table 16.	Document revision history	23

List of figures

Figure 1.	Block diagram	5
Figure 2.	Pin connection	5
Figure 3.	L3G4200D external low-pass filter values	6
Figure 4.	SPI slave timing diagram (2)	10
Figure 5.	I2C slave timing diagram (3)	11
Figure 6.	Block diagram	14
Figure 7.	Read and write protocol	18
Figure 8.	SPI read protocol	19
Figure 9.	Multiple bytes SPI read protocol (2 bytes example)	19
Figure 10.	SPI write protocol	19
Figure 11.	Multiple bytes SPI write protocol (2 bytes example)	20
Figure 12.	SPI read protocol in 3-wires mode	20
Figure 13.	LGA-16: mechanical data and package dimensions	22

1 Block diagram and pin description

Figure 1. Block diagram

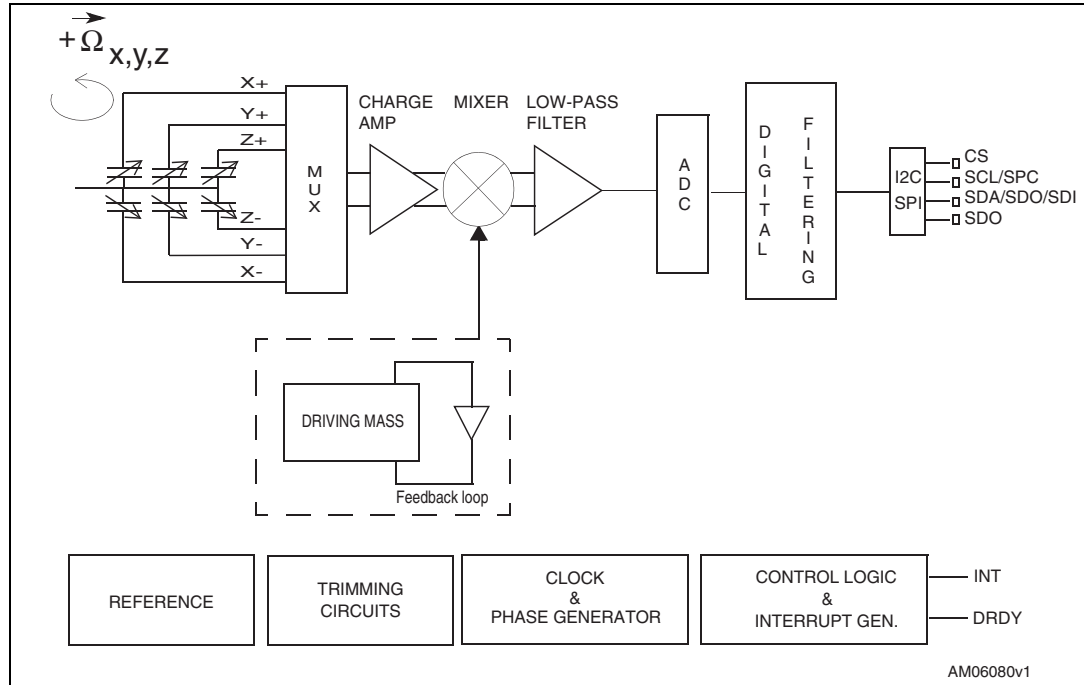

The vibration of the structure is maintained by a drive circuitry in a feedback loop. The sensing signal is filtered and appears as digital signal at the output.

1.1 Pin description

Figure 2. Pin connection

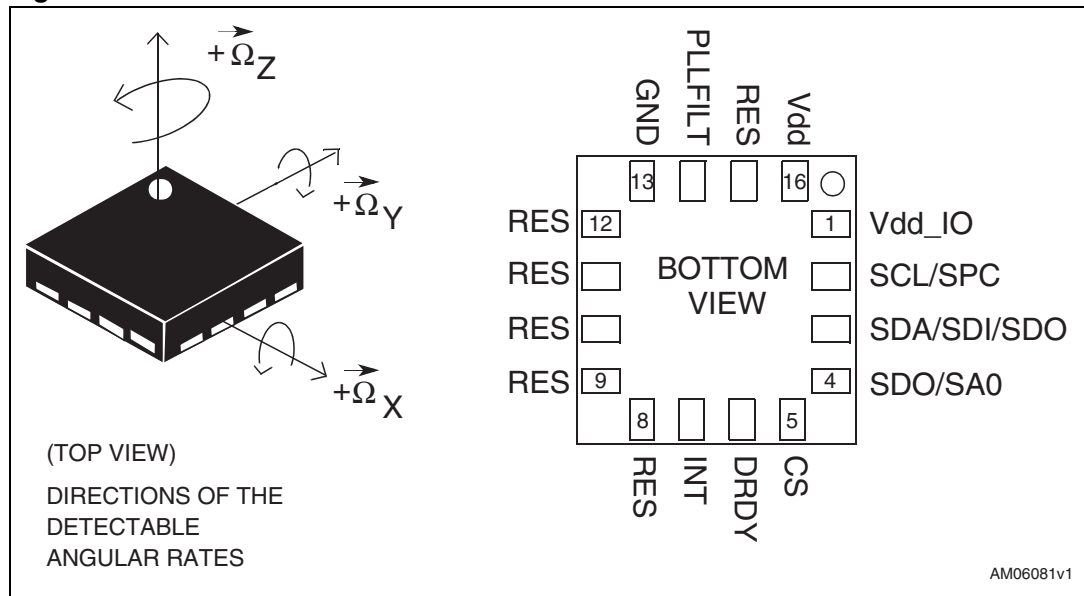

Table 2. Pin description

Pin#	Name	Function
1	Vdd_IO	Power supply for I/O pins
2	SCL SPC	I ² C serial clock (SCL) SPI serial port clock (SPC)
3	SDA SDI SDO	I ² C serial data (SDA) SPI serial data input (SDI) 3-wire interface serial data output (SDO)
4	SDO SA0	SPI serial data output (SDO) I ² C less significant bit of the device address (SA0)
5	CS	SPI enable I ² C/SPI mode selection (1: I ² C mode; 0: SPI enabled)
6	DRDY	Data ready
7	INT	Programmable Interrupt
8	Reserved	Connect to GND
9	Reserved	Connect to GND
10	Reserved	Connect to GND
11	Reserved	Connect to GND
12	Reserved	Connect to GND
13	GND	0 V supply
14	PLLFILT	Phase Locked Loop Filter (see <i>Figure_3</i>)
15	Reserved	Connect to Vdd
16	Vdd	Power supply

Figure 3. L3G4200D external low-pass filter values^(a)

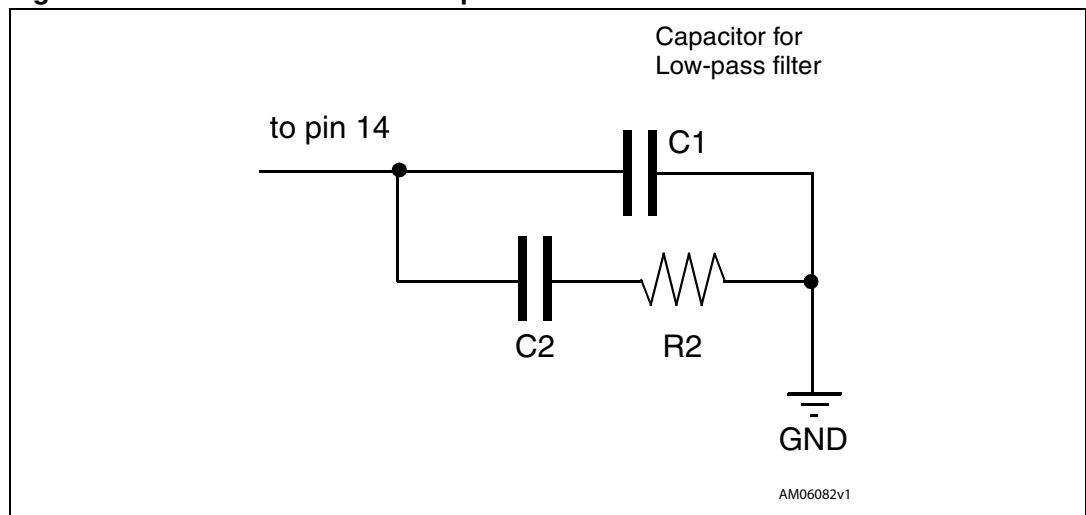

Table 3. Filter values

Component	Typical values
C1	10 nF
R2	10 k Ω
C2	470 pF

-
- a. Pin 14 PLLFILT maximum voltage level is equal to Vdd.

2 Mechanical and electrical specifications

2.1 Mechanical characteristics

Table 4. Mechanical characteristics @ Vdd = 3.0 V, T = 25 °C unless otherwise noted⁽¹⁾

Symbol	Parameter	Test condition	Min.	Typ. ⁽²⁾	Max.	Unit
FS	Angular rate range	User selectable		±250		dps
				±500		
				±2000		
So	Sensitivity	FS = 250 dps		8.75		mdps/digit
		FS = 500 dps		17.50		
		FS = 2000 dps		70		
SoDr	Sensitivity change vs. temperature	From -40 °C to +85 °C		±2		%
DVoff	Digital zero-rate level	FS = 250 dps		±10		dps
		FS = 500 dps		±15		
		FS = 2000 dps		±75		
OffDr	Zero-rate level change vs temperature	FS = 250 dps		±0.03		dps/°C
		FS = 2000 dps		±0.04		dps/°C
NL	Non linearity ⁽³⁾	Best fit straight line		0.2		% FS
DST	Self-test output change	FS = 250 dps		130		dps
		FS = 500 dps		200		
		FS = 2000 dps		530		
Rn	Rate noise density	BW = 40 Hz		0.03		dps/vHz
ODR	Digital output data rate			100/200/ 400/800		Hz
Top	Operating temperature range		-40		+85	°C

1. The product is factory calibrated at 3.0 V. The operational power supply range is specified in [Table 5](#).
2. Typical specifications are not guaranteed.
3. Guaranteed by design.

2.2 Electrical characteristics

Table 5. Electrical characteristics @ Vdd =3.0 V, T=25 °C unless otherwise noted⁽¹⁾

Symbol	Parameter	Test condition	Min.	Typ. ⁽²⁾	Max.	Unit
Vdd	Supply voltage		2.4	3.0	3.6	V
Vdd_IO	I/O pins supply voltage ⁽³⁾		1.71		Vdd+0.1	V
Idd	Supply current			6.1		mA
IddSL	Supply current in sleep mode ⁽⁴⁾	Selectable by digital interface		1.5		mA
IddPdn	Supply current in power-down mode			5		μA
Top	Operating temperature range		-40		+85	°C

1. The product is factory calibrated at 3.0V.
2. Typical specifications are not guaranteed.
3. It is possible to remove Vdd maintaining Vdd_IO without blocking the communication busses, in this condition the reading chain is powered off.
4. Sleep mode allows to reduce turn on time compared to Power down.

2.3 Communication interface characteristics

2.3.1 SPI - serial peripheral interface

Subject to general operating conditions for Vdd and Top.

Table 6. SPI slave timing values

Symbol	Parameter	Value ⁽¹⁾		Unit
		Min.	Max.	
tc(SPC)	SPI clock cycle	100		ns
fc(SPC)	SPI clock frequency		10	MHz
tsu(CS)	CS setup time	5		ns
th(CS)	CS hold time	8		
tsu(SI)	SDI input setup time	5		
th(SI)	SDI input hold time	15		
tv(SO)	SDO valid output time		50	
th(SO)	SDO output hold time	6		
tdis(SO)	SDO output disable time		50	

1. Values are guaranteed at 10 MHz clock frequency for SPI with both 4 and 3 wires, based on characterization results, not tested in production.

Figure 4. SPI slave timing diagram ⁽²⁾

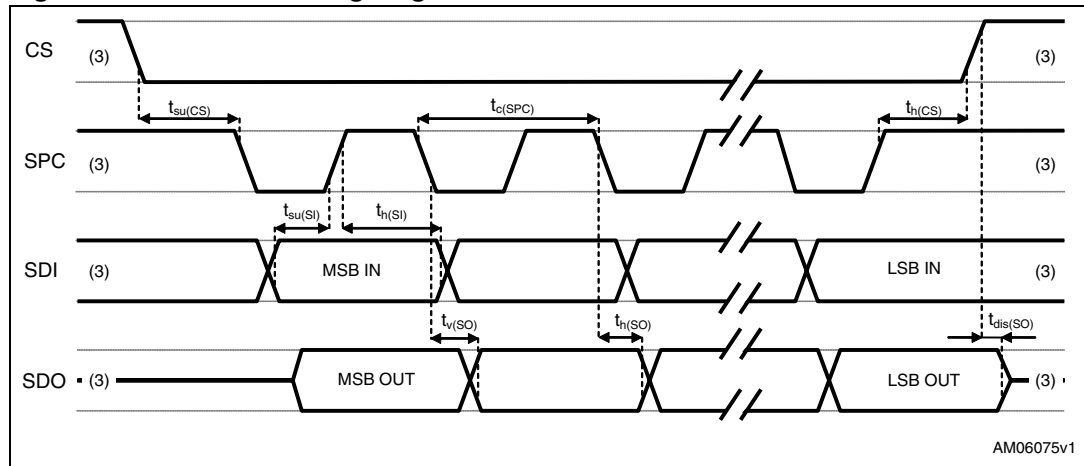

2. Measurement points are done at 0.2·Vdd_IO and 0.8·Vdd_IO, for both Input and Output port

2.3.2 I²C - Inter IC control interface

Subject to general operating conditions for Vdd and Top.

Table 7. I²C slave timing values

Symbol	Parameter	I ² C Standard mode ⁽¹⁾		I ² C Fast mode ⁽¹⁾		Unit
		Min	Max	Min	Max	
f _(SCL)	SCL clock frequency	0	100	0	400	kHz
t _{w(SCLL)}	SCL clock low time	4.7		1.3		
t _{w(SCLH)}	SCL clock high time	4.0		0.6		μs
t _{su(SDA)}	SDA setup time	250		100		ns
t _{h(SDA)}	SDA data hold time	0	3.45	0	0.9	μs
t _{r(SDA)} t _{r(SCL)}	SDA and SCL rise time		1000	20 + 0.1C _b ⁽²⁾	300	ns
t _{f(SDA)} t _{f(SCL)}	SDA and SCL fall time		300	20 + 0.1C _b ⁽²⁾	300	
t _{h(ST)}	START condition hold time	4		0.6		μs
t _{su(SR)}	Repeated START condition setup time	4.7		0.6		
t _{su(SP)}	STOP condition setup time	4		0.6		
t _{w(SP:SR)}	Bus free time between STOP and START condition	4.7		1.3		

1. Data based on standard I²C protocol requirement, not tested in production.
2. C_b = total capacitance of one bus line, in pF.

Figure 5. I²C slave timing diagram⁽³⁾

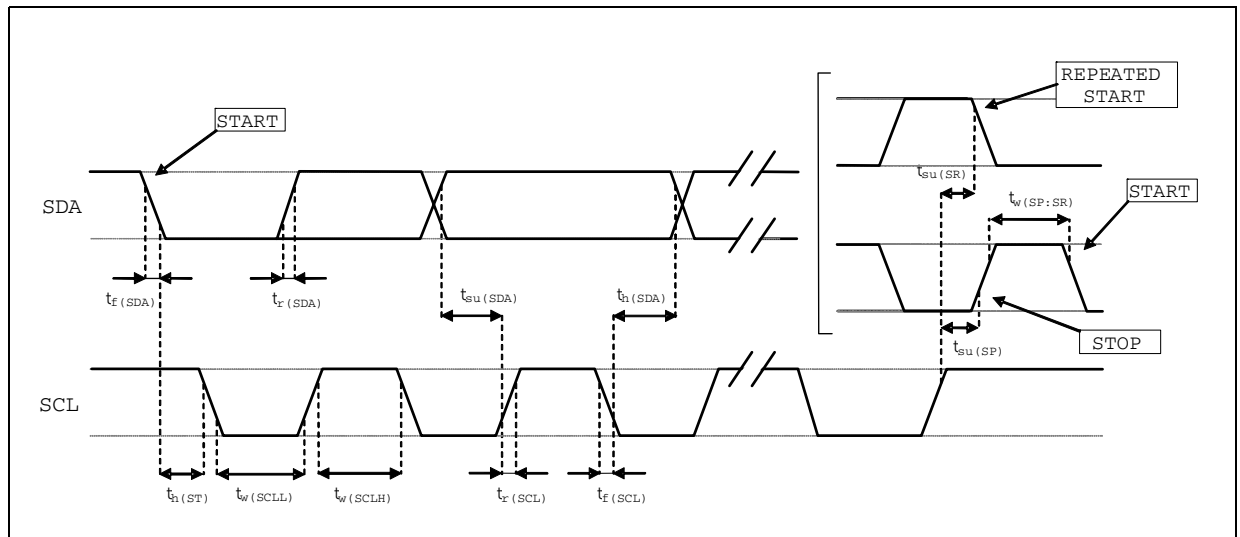

3 Measurement points are done at 0.2·Vdd_IO and 0.8·Vdd_IO, for both ports

3 Absolute maximum ratings

Stresses above those listed as “Absolute maximum ratings” may cause permanent damage to the device. This is a stress rating only and functional operation of the device under these conditions is not implied. Exposure to maximum rating conditions for extended periods may affect device reliability.

Table 8. Absolute maximum ratings

Symbol	Ratings	Maximum value	Unit
Vdd	Supply voltage	-0.3 to 4.8	V
T _{STG}	Storage temperature range	-40 to +125	°C
Sg	Acceleration g for 0.1 ms	10,000	<i>g</i>
ESD	Electrostatic discharge protection	2 (HBM)	kV



This is a mechanical shock sensitive device, improper handling can cause permanent damage to the part



This is an ESD sensitive device, improper handling can cause permanent damage to the part

3.1 Terminology

3.1.1 Sensitivity

An angular rate gyroscope is device that produces a positive-going digital output for counterclockwise rotation around the sensible axis considered. Sensitivity describes the gain of the sensor and can be determined by applying a defined angular velocity to it. This value changes very little over temperature and time.

3.1.2 Zero-rate level

Zero-rate level describes the actual output signal if there is no angular rate present. Zero-rate level of precise MEMS sensors is, to some extent, a result of stress to the sensor and therefore zero-rate level can slightly change after mounting the sensor onto a printed circuit board or after exposing it to extensive mechanical stress. This value changes very little over temperature and time.

3.1.3 Self-test

Self-test allows to test the mechanical and electric part of the sensor, allowing the seismic mass to be moved by means of an electrostatic test-force. When the ST is activated by IC, an actuation force is applied to the sensor, emulating a definite Coriolis force. In this case the sensor output will exhibit an output change.

3.2 Soldering information

The LGA package is compliant with the ECOPACK[®], RoHS and “Green” standard. It is qualified for soldering heat resistance according to JEDEC J-STD-020.

Leave “Pin 1 Indicator” unconnected during soldering.

Land pattern and soldering recommendations are available at www.st.com/mems.

4 Digital main blocks

4.1 Block diagram

Figure 6. Block diagram

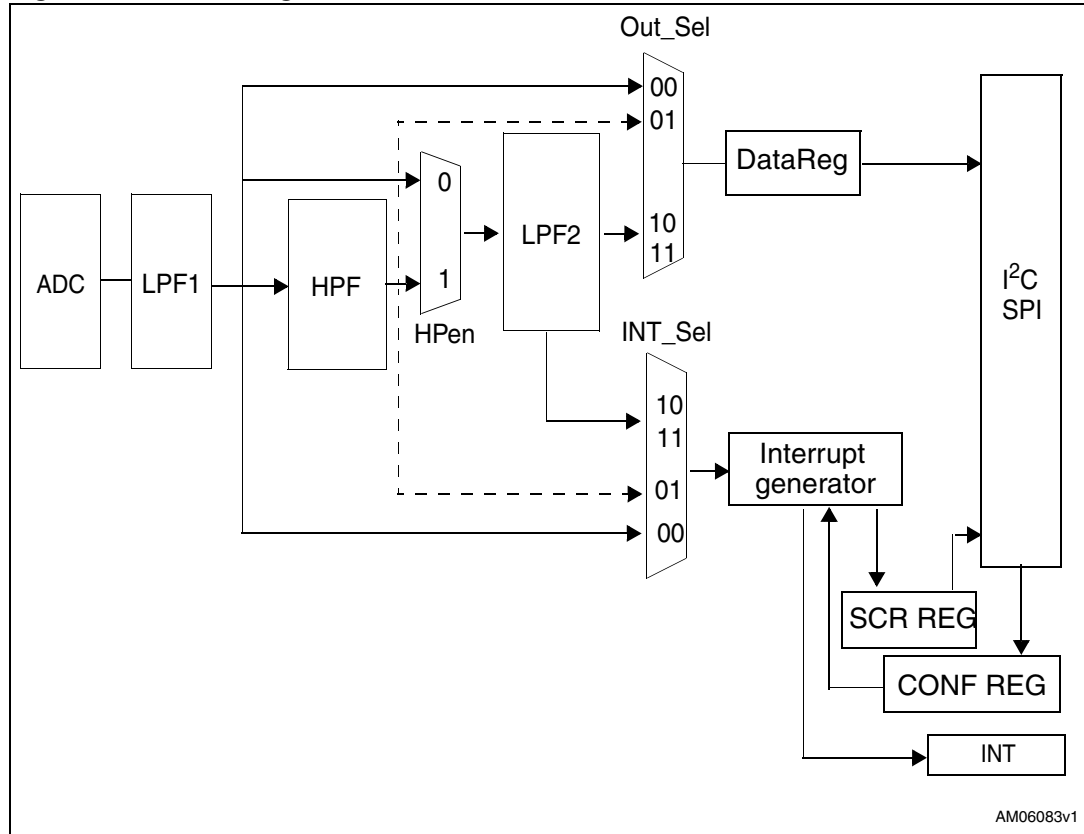

5 Digital interfaces

The registers embedded inside the L3G4200D may be accessed through both the I²C and SPI serial interfaces. The latter may be SW configured to operate either in 3-wire or 4-wire interface mode.

The serial interfaces are mapped onto the same pins. To select/exploit the I²C interface, CS line must be tied high (i.e connected to Vdd_IO).

Table 9. Serial interface pin description

Pin name	Pin description
CS	SPI enable I ² C/SPI mode selection (1: I ² C mode; 0: SPI enabled)
SCL/SPC	I ² C Serial Clock (SCL) SPI Serial Port Clock (SPC)
SDA/SDI/SDO	I ² C Serial Data (SDA) SPI Serial Data Input (SDI) 3-wire Interface Serial Data Output (SDO)
SDO	SPI Serial Data Output (SDO) I ² C less significant bit of the device address

5.1 I²C serial interface

The L3G4200D I²C is a bus slave. The I²C is employed to write data into registers whose content can also be read back.

The relevant I²C terminology is given in the table below.

Table 10. I²C terminology

Term	Description
Transmitter	The device which sends data to the bus
Receiver	The device which receives data from the bus
Master	The device which initiates a transfer, generates clock signals and terminates a transfer
Slave	The device addressed by the master

There are two signals associated with the I²C bus: the Serial Clock Line (SCL) and the serial data line (SDA). The latter is a bidirectional line used for sending and receiving the data to/from the interface. Both the lines must be connected to Vdd_IO through external pull-up resistor. When the bus is free both the lines are high.

The I²C interface is compliant with fast mode (400 kHz) I²C standards as well as with the normal mode.

5.1.1 I²C operation

The transaction on the bus is started through a START (ST) signal. A START condition is defined as a HIGH to LOW transition on the data line while the SCL line is held HIGH. After this has been transmitted by the Master, the bus is considered busy. The next byte of data transmitted after the start condition contains the address of the slave in the first 7 bits and the eighth bit tells whether the Master is receiving data from the slave or transmitting data to the slave. When an address is sent, each device in the system compares the first seven bits after a start condition with its address. If they match, the device considers itself addressed by the Master.

The Slave ADDRESS (SAD) associated to the L3G4200D is 110100xb. **SDO** pin can be used to modify less significant bit of the device address. If SDO pin is connected to voltage supply LSb is '1' (address 1101001b) else if SDO pin is connected to ground LSb value is '0' (address 1101000b). This solution permits to connect and address two different gyroscopes to the same I²C bus.

Data transfer with acknowledge is mandatory. The transmitter must release the SDA line during the acknowledge pulse. The receiver must then pull the data line LOW so that it remains stable low during the HIGH period of the acknowledge clock pulse. A receiver which has been addressed is obliged to generate an acknowledge after each byte of data received.

The I²C embedded inside the L3G4200D behaves like a slave device and the following protocol must be adhered to. After the start condition (ST) a slave address is sent, once a slave acknowledge (SAK) has been returned, a 8-bit sub-address will be transmitted: the 7 LSb represent the actual register address while the MSB enables address auto increment. If the MSb of the SUB field is 1, the SUB (register address) will be automatically incremented to allow multiple data read/write.

The slave address is completed with a Read/Write bit. If the bit was '1' (Read), a repeated START (SR) condition will have to be issued after the two sub-address bytes; if the bit is '0' (Write) the Master will transmit to the slave with direction unchanged. [Table 11](#) explains how the SAD+Read/Write bit pattern is composed, listing all the possible configurations.

Table 11. SAD+Read/Write patterns

Command	SAD[6:1]	SAD[0] = SDO	R/W	SAD+R/W
Read	110100	0	1	11010001 (D1h)
Write	110100	0	0	11010000 (D0h)
Read	110100	1	1	11010011 (D3h)
Write	110100	1	0	11010010 (D2h)

Table 12. Transfer when Master is writing one byte to slave

Master	ST	SAD + W		SUB		DATA		SP
Slave			SAK		SAK		SAK	

Table 13. Transfer when Master is writing multiple bytes to slave

Master	ST	SAD + W		SUB		DATA		DATA		SP
Slave			SAK		SAK		SAK		SAK	

Table 14. Transfer when Master is receiving (reading) one byte of data from slave

Master	ST	SAD + W		SUB		SR	SAD + R			NMAK	SP
Slave			SAK		SAK			SAK	DATA		

Table 15. Transfer when Master is receiving (reading) multiple bytes of data from slave

Master	ST	SAD+W		SUB		SR	SAD+R			MAK		MAK		NMAK	SP
Slave			SAK		SAK			SAK	DATA		DATA		DATA		

Data are transmitted in byte format (DATA). Each data transfer contains 8 bits. The number of bytes transferred per transfer is unlimited. Data is transferred with the Most Significant bit (MSb) first. If a receiver can't receive another complete byte of data until it has performed some other function, it can hold the clock line, SCL LOW to force the transmitter into a wait state. Data transfer only continues when the receiver is ready for another byte and releases the data line. If a slave receiver doesn't acknowledge the slave address (i.e. it is not able to receive because it is performing some real time function) the data line must be left HIGH by the slave. The Master can then abort the transfer. A LOW to HIGH transition on the SDA line while the SCL line is HIGH is defined as a STOP condition. Each data transfer must be terminated by the generation of a STOP (SP) condition.

In order to read multiple bytes, it is necessary to assert the most significant bit of the sub-address field. In other words, SUB(7) must be equal to 1 while SUB(6-0) represents the address of first register to be read.

In the presented communication format MAK is Master Acknowledge and NMAK is No Master Acknowledge.

5.2 SPI bus interface

The SPI is a bus slave. The SPI allows to write and read the registers of the device.

The Serial Interface interacts with the outside world with 4 wires: **CS**, **SPC**, **SDI** and **SDO**.

Figure 7. Read and write protocol

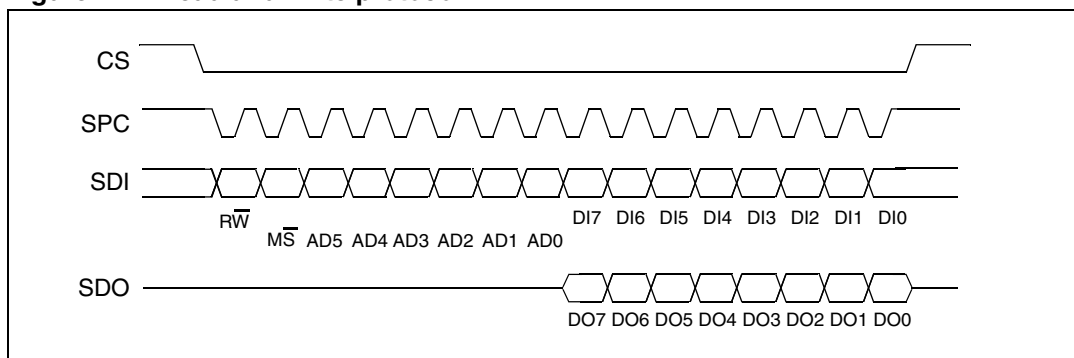

CS is the Serial Port Enable and it is controlled by the SPI master. It goes low at the start of the transmission and goes back high at the end. **SPC** is the Serial Port Clock and it is controlled by the SPI master. It is stopped high when **CS** is high (no transmission). **SDI** and **SDO** are respectively the Serial Port Data Input and Output. Those lines are driven at the falling edge of **SPC** and should be captured at the rising edge of **SPC**.

Both the Read Register and Write Register commands are completed in 16 clock pulses or in multiple of 8 in case of multiple bytes read/write. Bit duration is the time between two falling edges of **SPC**. The first bit (bit 0) starts at the first falling edge of **SPC** after the falling edge of **CS** while the last bit (bit 15, bit 23, ...) starts at the last falling edge of **SPC** just before the rising edge of **CS**.

bit 0: \overline{RW} bit. When 0, the data DI(7:0) is written into the device. When 1, the data DO(7:0) from the device is read. In latter case, the chip will drive **SDO** at the start of bit 8.

bit 1: \overline{MS} bit. When 0, the address will remain unchanged in multiple read/write commands. When 1, the address will be auto incremented in multiple read/write commands.

bit 2-7: address AD(5:0). This is the address field of the indexed register.

bit 8-15: data DI(7:0) (write mode). This is the data that will be written into the device (MSb first).

bit 8-15: data DO(7:0) (read mode). This is the data that will be read from the device (MSb first).

In multiple read/write commands further blocks of 8 clock periods will be added. When \overline{MS} bit is 0 the address used to read/write data remains the same for every block. When \overline{MS} bit is 1 the address used to read/write data is incremented at every block.

The function and the behavior of **SDI** and **SDO** remain unchanged.

5.2.1 SPI read

Figure 8. SPI read protocol

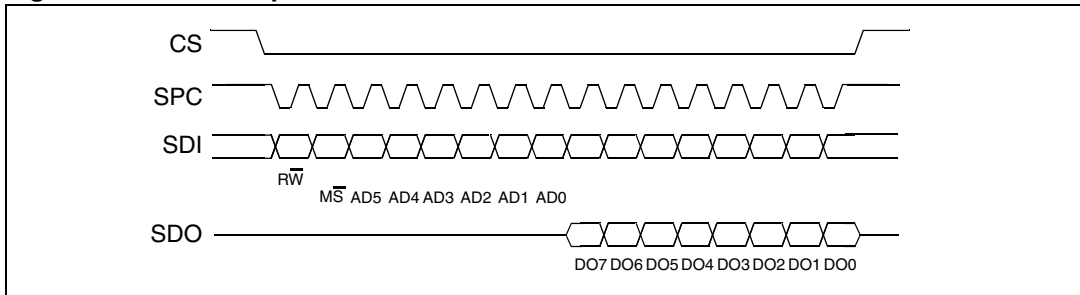

The SPI Read command is performed with 16 clock pulses. Multiple byte read command is performed adding blocks of 8 clock pulses at the previous one.

bit 0: READ bit. The value is 1.

bit 1: \overline{MS} bit. When 0 do not increment address, when 1 increment address in multiple reading.

bit 2-7: address AD(5:0). This is the address field of the indexed register.

bit 8-15: data DO(7:0) (read mode). This is the data that will be read from the device (\overline{MS} first).

bit 16-... : data DO(...-8). Further data in multiple byte reading.

Figure 9. Multiple bytes SPI read protocol (2 bytes example)

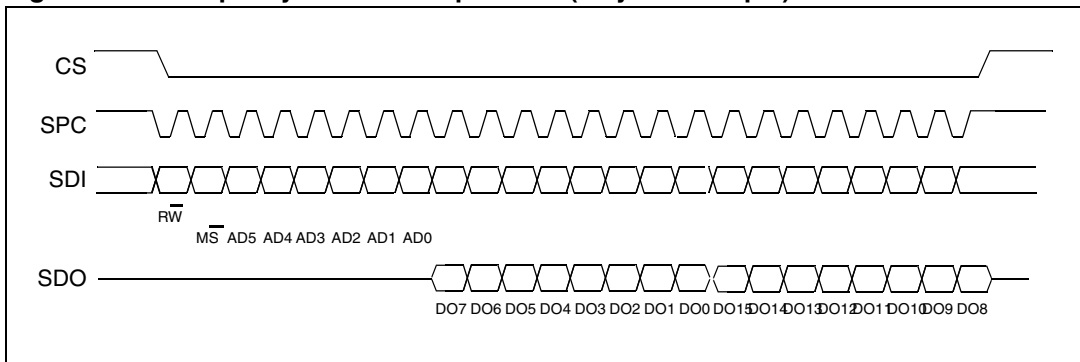

5.2.2 SPI write

Figure 10. SPI write protocol

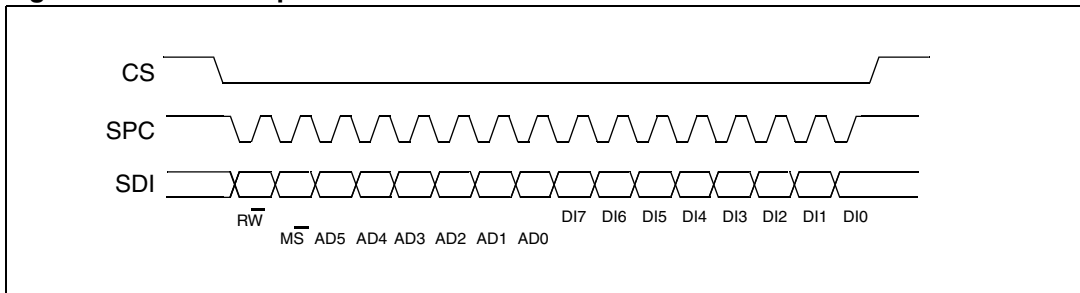

The SPI Write command is performed with 16 clock pulses. Multiple byte write command is performed adding blocks of 8 clock pulses at the previous one.

bit 0: WRITE bit. The value is 0.

bit 1: \overline{MS} bit. When 0 do not increment address, when 1 increment address in multiple writing.

bit 2 -7: address AD(5:0). This is the address field of the indexed register.

bit 8-15: data DI(7:0) (write mode). This is the data that will be written inside the device (MSb first).

bit 16-... : data DI(...-8). Further data in multiple byte writing.

Figure 11. Multiple bytes SPI write protocol (2 bytes example)

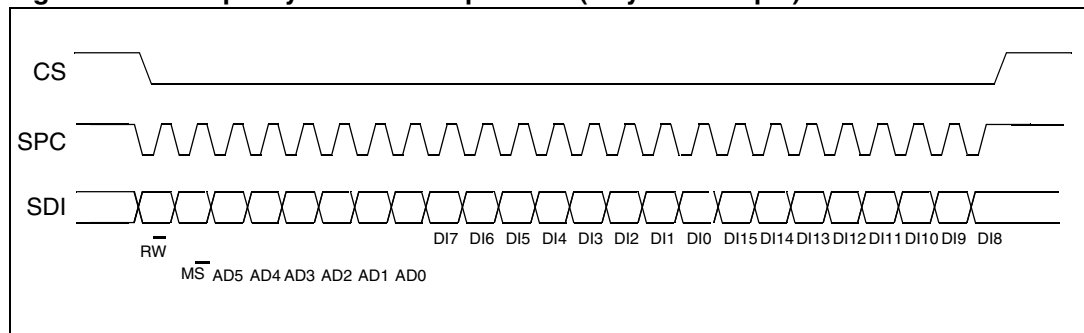

5.2.3 SPI read in 3-wires mode

3-wires mode is entered by setting to 1 bit SIM (SPI serial interface mode selection) in CTRL_REG2.

Figure 12. SPI read protocol in 3-wires mode

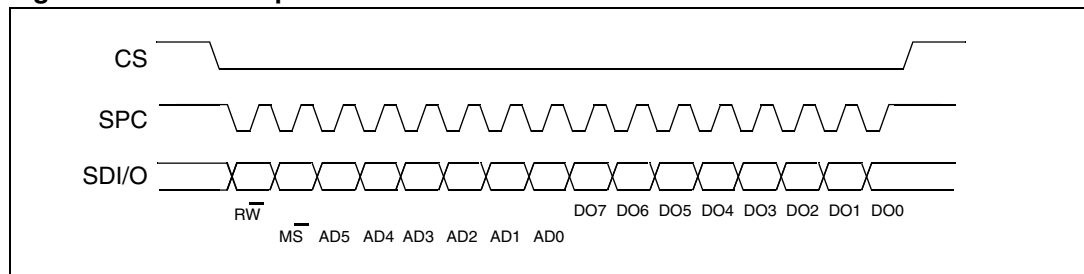

The SPI Read command is performed with 16 clock pulses:

bit 0: READ bit. The value is 1.

bit 1: \overline{MS} bit. When 0 do not increment address, when 1 increment address in multiple reading.

bit 2-7: address AD(5:0). This is the address field of the indexed register.

bit 8-15: data DO(7:0) (read mode). This is the data that will be read from the device (MSb first).

Multiple read command is also available in 3-wires mode.

6 Package information

In order to meet environmental requirements, ST offers these devices in different grades of ECOPACK[®] packages, depending on their level of environmental compliance. ECOPACK[®] specifications, grade definitions and product status are available at: www.st.com. ECOPACK is an ST trademark.

Figure 13. LGA-16: mechanical data and package dimensions

Ref.	Dimensions		
	mm		
	Min.	Typ.	Max.
A1			1.100
A2		0.855	
A3		0.200	
d		0.300	
D1	3.850	4.000	4.150
E1	3.850	4.000	4.150
L2		1.950	
M		0.100	
N1		0.650	
N2		0.975	
P1		1.750	
P2		1.525	
T1		0.400	
T2		0.300	
k		0.050	

Outline and mechanical data

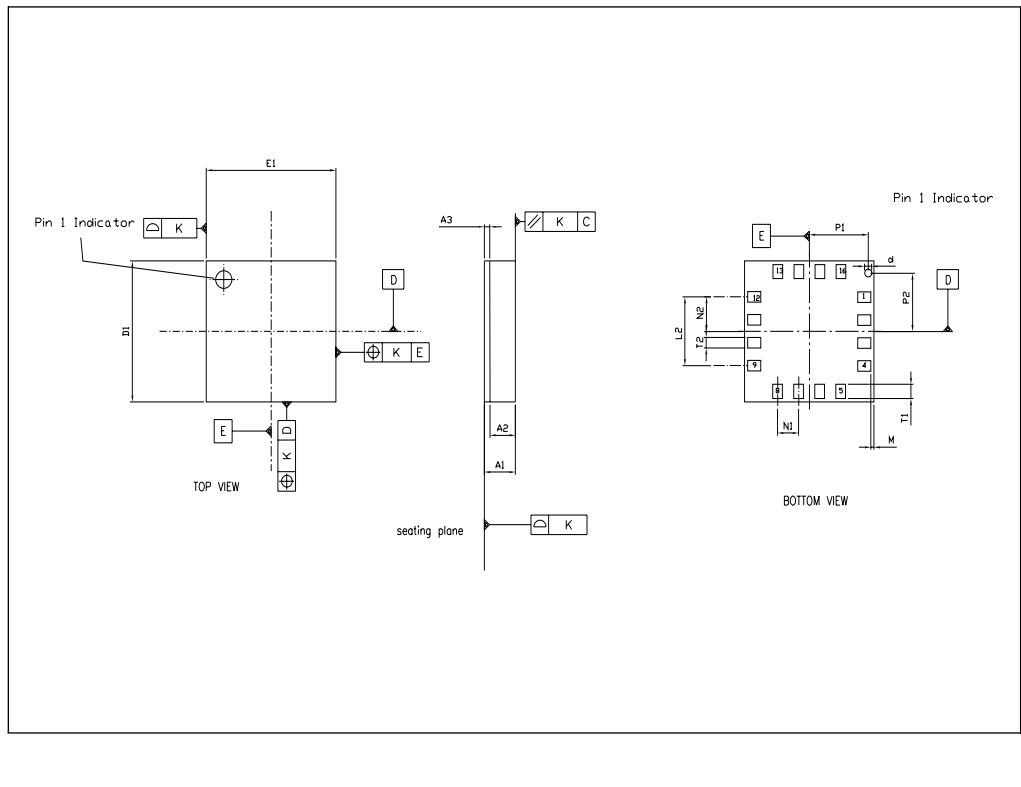
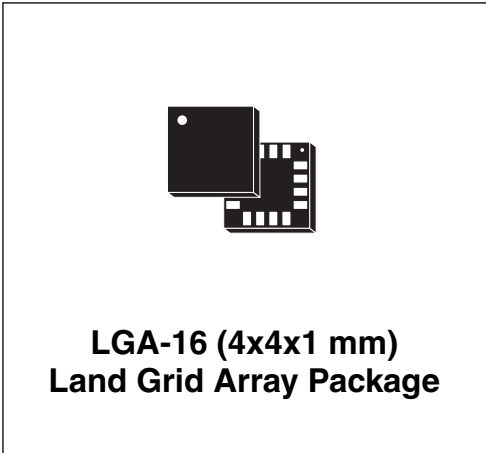

7 Revision history

Table 16. Document revision history

Date	Revision	Changes
11-Feb-2010	1	First release.

Please Read Carefully:

Information in this document is provided solely in connection with ST products. STMicroelectronics NV and its subsidiaries ("ST") reserve the right to make changes, corrections, modifications or improvements, to this document, and the products and services described herein at any time, without notice.

All ST products are sold pursuant to ST's terms and conditions of sale.

Purchasers are solely responsible for the choice, selection and use of the ST products and services described herein, and ST assumes no liability whatsoever relating to the choice, selection or use of the ST products and services described herein.

No license, express or implied, by estoppel or otherwise, to any intellectual property rights is granted under this document. If any part of this document refers to any third party products or services it shall not be deemed a license grant by ST for the use of such third party products or services, or any intellectual property contained therein or considered as a warranty covering the use in any manner whatsoever of such third party products or services or any intellectual property contained therein.

UNLESS OTHERWISE SET FORTH IN ST'S TERMS AND CONDITIONS OF SALE ST DISCLAIMS ANY EXPRESS OR IMPLIED WARRANTY WITH RESPECT TO THE USE AND/OR SALE OF ST PRODUCTS INCLUDING WITHOUT LIMITATION IMPLIED WARRANTIES OF MERCHANTABILITY, FITNESS FOR A PARTICULAR PURPOSE (AND THEIR EQUIVALENTS UNDER THE LAWS OF ANY JURISDICTION), OR INFRINGEMENT OF ANY PATENT, COPYRIGHT OR OTHER INTELLECTUAL PROPERTY RIGHT.

UNLESS EXPRESSLY APPROVED IN WRITING BY AN AUTHORIZED ST REPRESENTATIVE, ST PRODUCTS ARE NOT RECOMMENDED, AUTHORIZED OR WARRANTED FOR USE IN MILITARY, AIR CRAFT, SPACE, LIFE SAVING, OR LIFE SUSTAINING APPLICATIONS, NOR IN PRODUCTS OR SYSTEMS WHERE FAILURE OR MALFUNCTION MAY RESULT IN PERSONAL INJURY, DEATH, OR SEVERE PROPERTY OR ENVIRONMENTAL DAMAGE. ST PRODUCTS WHICH ARE NOT SPECIFIED AS "AUTOMOTIVE GRADE" MAY ONLY BE USED IN AUTOMOTIVE APPLICATIONS AT USER'S OWN RISK.

Resale of ST products with provisions different from the statements and/or technical features set forth in this document shall immediately void any warranty granted by ST for the ST product or service described herein and shall not create or extend in any manner whatsoever, any liability of ST.

ST and the ST logo are trademarks or registered trademarks of ST in various countries.

Information in this document supersedes and replaces all information previously supplied.

The ST logo is a registered trademark of STMicroelectronics. All other names are the property of their respective owners.

© 2010 STMicroelectronics - All rights reserved

STMicroelectronics group of companies

Australia - Belgium - Brazil - Canada - China - Czech Republic - Finland - France - Germany - Hong Kong - India - Israel - Italy - Japan - Malaysia - Malta - Morocco - Philippines - Singapore - Spain - Sweden - Switzerland - United Kingdom - United States of America

www.st.com