

L293, L293D QUADRUPLE HALF-H DRIVERS

SLRS008C – SEPTEMBER 1986 – REVISED NOVEMBER 2004

- Featuring Unitorde L293 and L293D Products Now From Texas Instruments
- Wide Supply-Voltage Range: 4.5 V to 36 V
- Separate Input-Logic Supply
- Internal ESD Protection
- Thermal Shutdown
- High-Noise-Immunity Inputs
- Functionally Similar to SGS L293 and SGS L293D
- Output Current 1 A Per Channel (600 mA for L293D)
- Peak Output Current 2 A Per Channel (1.2 A for L293D)
- Output Clamp Diodes for Inductive Transient Suppression (L293D)

description/ordering information

The L293 and L293D are quadruple high-current half-H drivers. The L293 is designed to provide bidirectional drive currents of up to 1 A at voltages from 4.5 V to 36 V. The L293D is designed to provide bidirectional drive currents of up to 600-mA at voltages from 4.5 V to 36 V. Both devices are designed to drive inductive loads such as relays, solenoids, dc and bipolar stepping motors, as well as other high-current/high-voltage loads in positive-supply applications.

All inputs are TTL compatible. Each output is a complete totem-pole drive circuit, with a Darlington transistor sink and a pseudo-Darlington source. Drivers are enabled in pairs, with drivers 1 and 2 enabled by 1,2EN and drivers 3 and 4 enabled by 3,4EN. When an enable input is high, the associated drivers are enabled, and their outputs are active and in phase with their inputs. When the enable input is low, those drivers are disabled, and their outputs are off and in the high-impedance state. With the proper data inputs, each pair of drivers forms a full-H (or bridge) reversible drive suitable for solenoid or motor applications.

L293 . . . N OR NE PACKAGE
L293D . . . NE PACKAGE
(TOP VIEW)

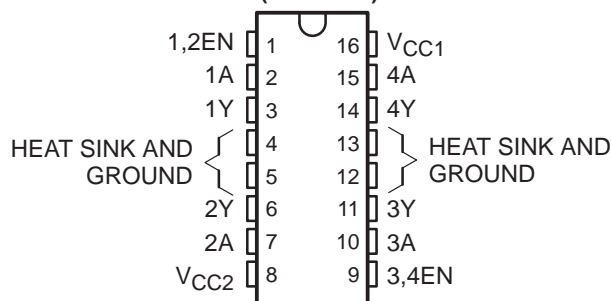

L293 . . . DWP PACKAGE
(TOP VIEW)

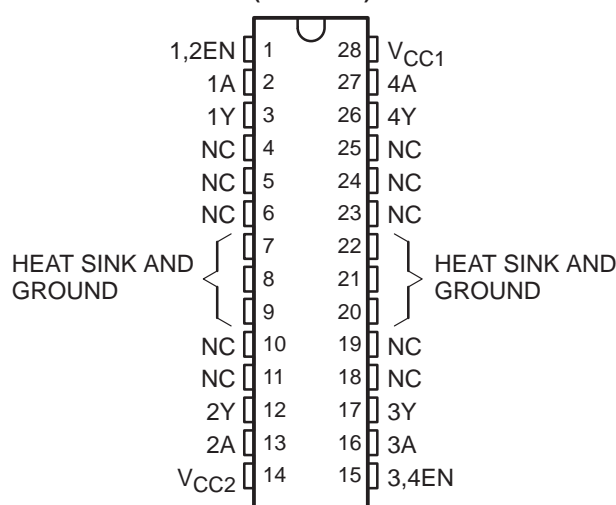

ORDERING INFORMATION

T _A	PACKAGE†		ORDERABLE PART NUMBER	TOP-SIDE MARKING
0°C to 70°C	HSOP (DWP)	Tube of 20	L293DWP	L293DWP
	PDIP (N)	Tube of 25	L293N	L293N
	PDIP (NE)	Tube of 25	L293NE	L293NE
		Tube of 25	L293DNE	L293DNE

† Package drawings, standard packing quantities, thermal data, symbolization, and PCB design guidelines are available at www.ti.com/sc/package.



Please be aware that an important notice concerning availability, standard warranty, and use in critical applications of Texas Instruments semiconductor products and disclaimers thereto appears at the end of this data sheet.

PRODUCTION DATA information is current as of publication date. Products conform to specifications per the terms of Texas Instruments standard warranty. Production processing does not necessarily include testing of all parameters.

 **TEXAS
INSTRUMENTS**

POST OFFICE BOX 655303 • DALLAS, TEXAS 75265

Copyright © 2004, Texas Instruments Incorporated

L293, L293D QUADRUPLE HALF-H DRIVERS

SLRS008C – SEPTEMBER 1986 – REVISED NOVEMBER 2004

description/ordering information (continued)

On the L293, external high-speed output clamp diodes should be used for inductive transient suppression. A V_{CC1} terminal, separate from V_{CC2} , is provided for the logic inputs to minimize device power dissipation. The L293 and L293D are characterized for operation from 0°C to 70°C.

block diagram

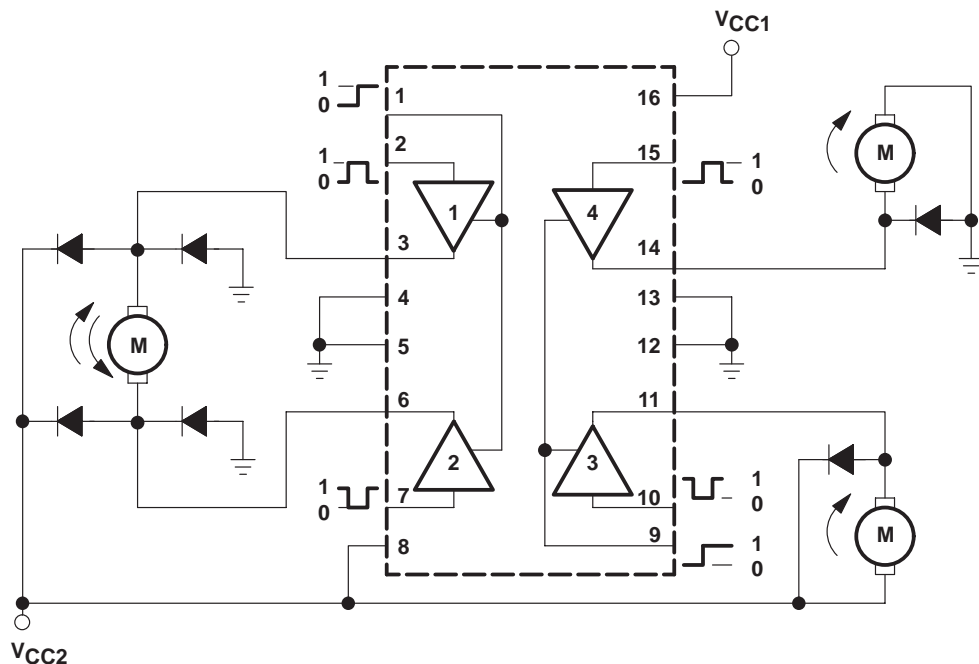

NOTE: Output diodes are internal in L293D.

FUNCTION TABLE
(each driver)

INPUTS†		OUTPUT
A	EN	Y
H	H	H
L	H	L
X	L	Z

H = high level, L = low level, X = irrelevant,
Z = high impedance (off)

† In the thermal shutdown mode, the output is in the high-impedance state, regardless of the input levels.

logic diagram

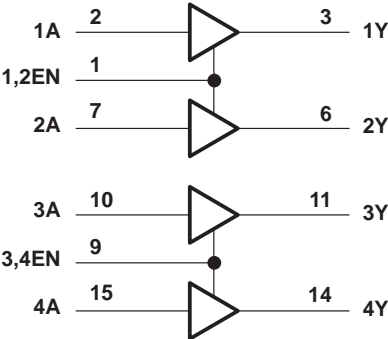

schematics of inputs and outputs (L293)

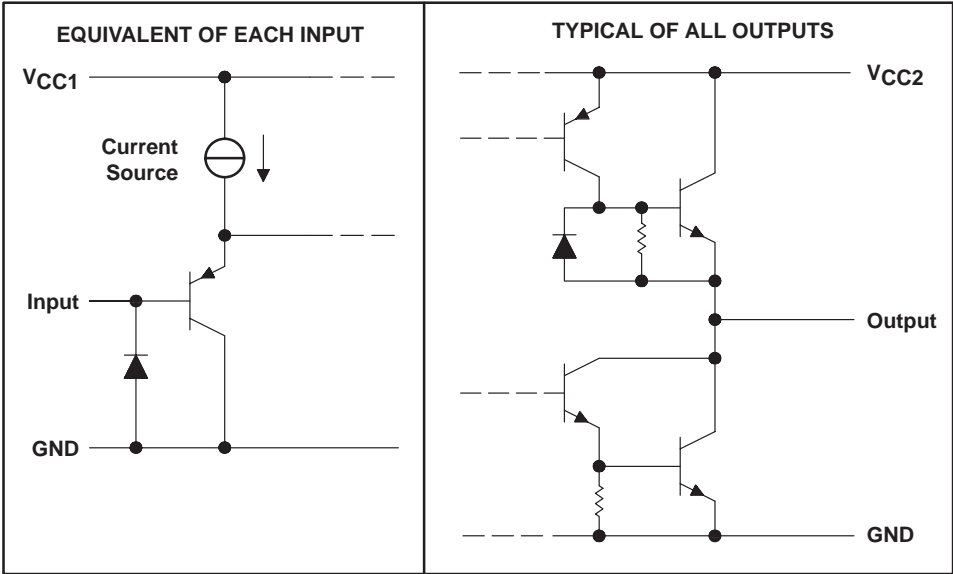

L293, L293D QUADRUPLE HALF-H DRIVERS

SLRS008C – SEPTEMBER 1986 – REVISED NOVEMBER 2004

schematics of inputs and outputs (L293D)

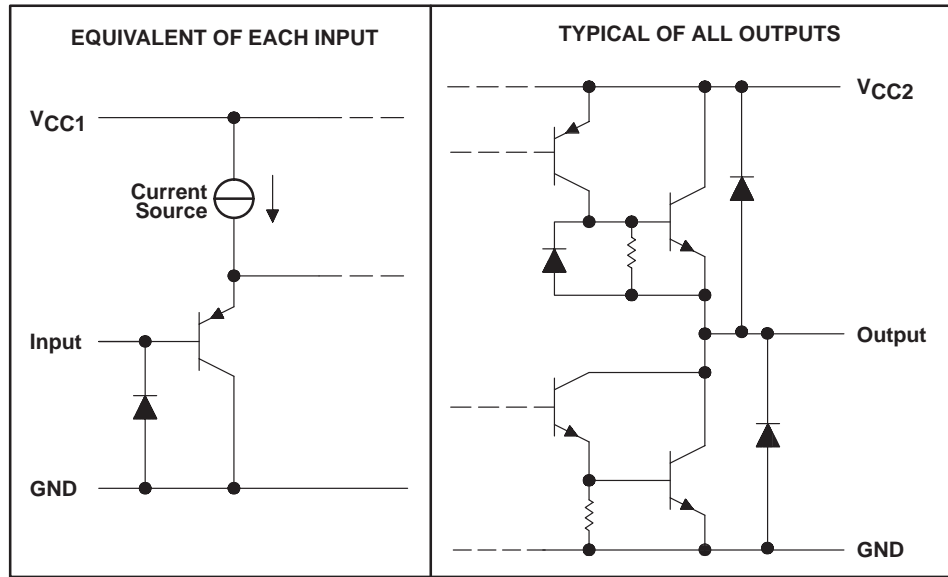

absolute maximum ratings over operating free-air temperature range (unless otherwise noted)†

Supply voltage, V_{CC1} (see Note 1)	36 V
Output supply voltage, V_{CC2}	36 V
Input voltage, V_I	7 V
Output voltage range, V_O	-3 V to $V_{CC2} + 3$ V
Peak output current, I_O (nonrepetitive, $t \leq 5$ ms): L293	± 2 A
Peak output current, I_O (nonrepetitive, $t \leq 100 \mu\text{s}$): L293D	± 1.2 A
Continuous output current, I_O : L293	± 1 A
Continuous output current, I_O : L293D	± 600 mA
Package thermal impedance, θ_{JA} (see Notes 2 and 3): DWP package	TBD°C/W
N package	67°C/W
NE package	TBD°C/W
Maximum junction temperature, T_J	150°C
Storage temperature range, T_{stg}	-65°C to 150°C

† Stresses beyond those listed under “absolute maximum ratings” may cause permanent damage to the device. These are stress ratings only, and functional operation of the device at these or any other conditions beyond those indicated under “recommended operating conditions” is not implied. Exposure to absolute-maximum-rated conditions for extended periods may affect device reliability.

- NOTES:
- All voltage values are with respect to the network ground terminal.
 - Maximum power dissipation is a function of $T_J(\text{max})$, θ_{JA} , and T_A . The maximum allowable power dissipation at any allowable ambient temperature is $P_D = (T_J(\text{max}) - T_A) / \theta_{JA}$. Operating at the absolute maximum T_J of 150°C can affect reliability.
 - The package thermal impedance is calculated in accordance with JESD 51-7.

L293, L293D QUADRUPLE HALF-H DRIVERS

SLRS008C – SEPTEMBER 1986 – REVISED NOVEMBER 2004

recommended operating conditions

		MIN	MAX	UNIT
Supply voltage	V _{CC1}	4.5	7	V
	V _{CC2}	V _{CC1}	36	
V _{IH} High-level input voltage	V _{CC1} ≤ 7 V	2.3	V _{CC1}	V
	V _{CC1} ≥ 7 V	2.3	7	V
V _{IL} Low-level output voltage		-0.3†	1.5	V
T _A Operating free-air temperature		0	70	°C

† The algebraic convention, in which the least positive (most negative) designated minimum, is used in this data sheet for logic voltage levels.

electrical characteristics, V_{CC1} = 5 V, V_{CC2} = 24 V, T_A = 25°C

PARAMETER		TEST CONDITIONS		MIN	TYP	MAX	UNIT
V _{OH} High-level output voltage		L293: I _{OH} = -1 A L293D: I _{OH} = -0.6 A		V _{CC2} - 1.8	V _{CC2} - 1.4		V
V _{OL} Low-level output voltage		L293: I _{OL} = 1 A L293D: I _{OL} = 0.6 A			1.2	1.8	V
V _{OKH} High-level output clamp voltage		L293D: I _{OK} = -0.6 A			V _{CC2} + 1.3		V
V _{OKL} Low-level output clamp voltage		L293D: I _{OK} = 0.6 A			1.3		V
I _{IH} High-level input current	A	V _I = 7 V			0.2	100	μA
	EN					0.2	
I _{IL} Low-level input current	A	V _I = 0			-3	-10	μA
	EN					-2	
I _{CC1} Logic supply current		I _O = 0	All outputs at high level		13	22	mA
			All outputs at low level		35	60	
			All outputs at high impedance		8	24	
I _{CC2} Output supply current		I _O = 0	All outputs at high level		14	24	mA
			All outputs at low level		2	6	
			All outputs at high impedance		2	4	

switching characteristics, V_{CC1} = 5 V, V_{CC2} = 24 V, T_A = 25°C

PARAMETER	TEST CONDITIONS	L293NE, L293DNE			UNIT
		MIN	TYP	MAX	
t _{PLH} Propagation delay time, low-to-high-level output from A input	C _L = 30 pF, See Figure 1		800		ns
t _{PHL} Propagation delay time, high-to-low-level output from A input			400		ns
t _{TLH} Transition time, low-to-high-level output			300		ns
t _{THL} Transition time, high-to-low-level output			300		ns

switching characteristics, V_{CC1} = 5 V, V_{CC2} = 24 V, T_A = 25°C

PARAMETER	TEST CONDITIONS	L293DWP, L293N L293DN			UNIT
		MIN	TYP	MAX	
t _{PLH} Propagation delay time, low-to-high-level output from A input	C _L = 30 pF, See Figure 1		750		ns
t _{PHL} Propagation delay time, high-to-low-level output from A input			200		ns
t _{TLH} Transition time, low-to-high-level output			100		ns
t _{THL} Transition time, high-to-low-level output			350		ns



L293, L293D QUADRUPLE HALF-H DRIVERS

SLRS008C – SEPTEMBER 1986 – REVISED NOVEMBER 2004

PARAMETER MEASUREMENT INFORMATION

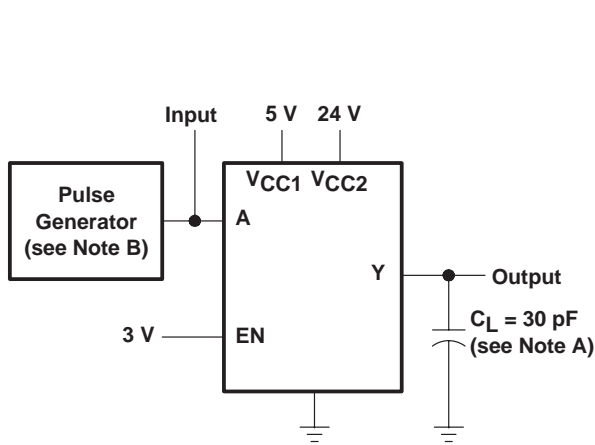

TEST CIRCUIT

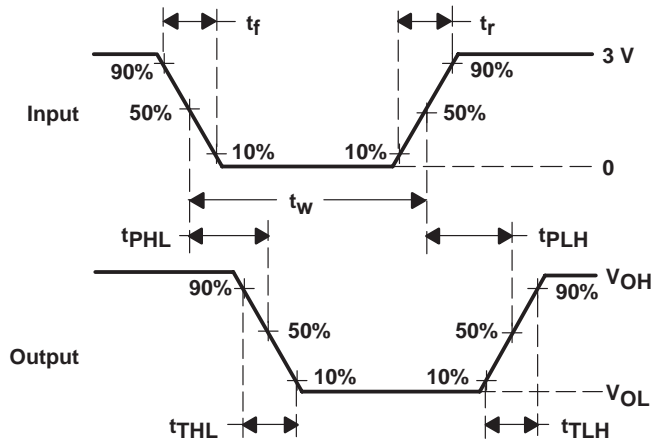

VOLTAGE WAVEFORMS

- NOTES: A. C_L includes probe and jig capacitance.
 B. The pulse generator has the following characteristics: $t_r \leq 10$ ns, $t_f \leq 10$ ns, $t_w = 10$ μ s, PRR = 5 kHz, $Z_O = 50$ Ω .

Figure 1. Test Circuit and Voltage Waveforms

APPLICATION INFORMATION

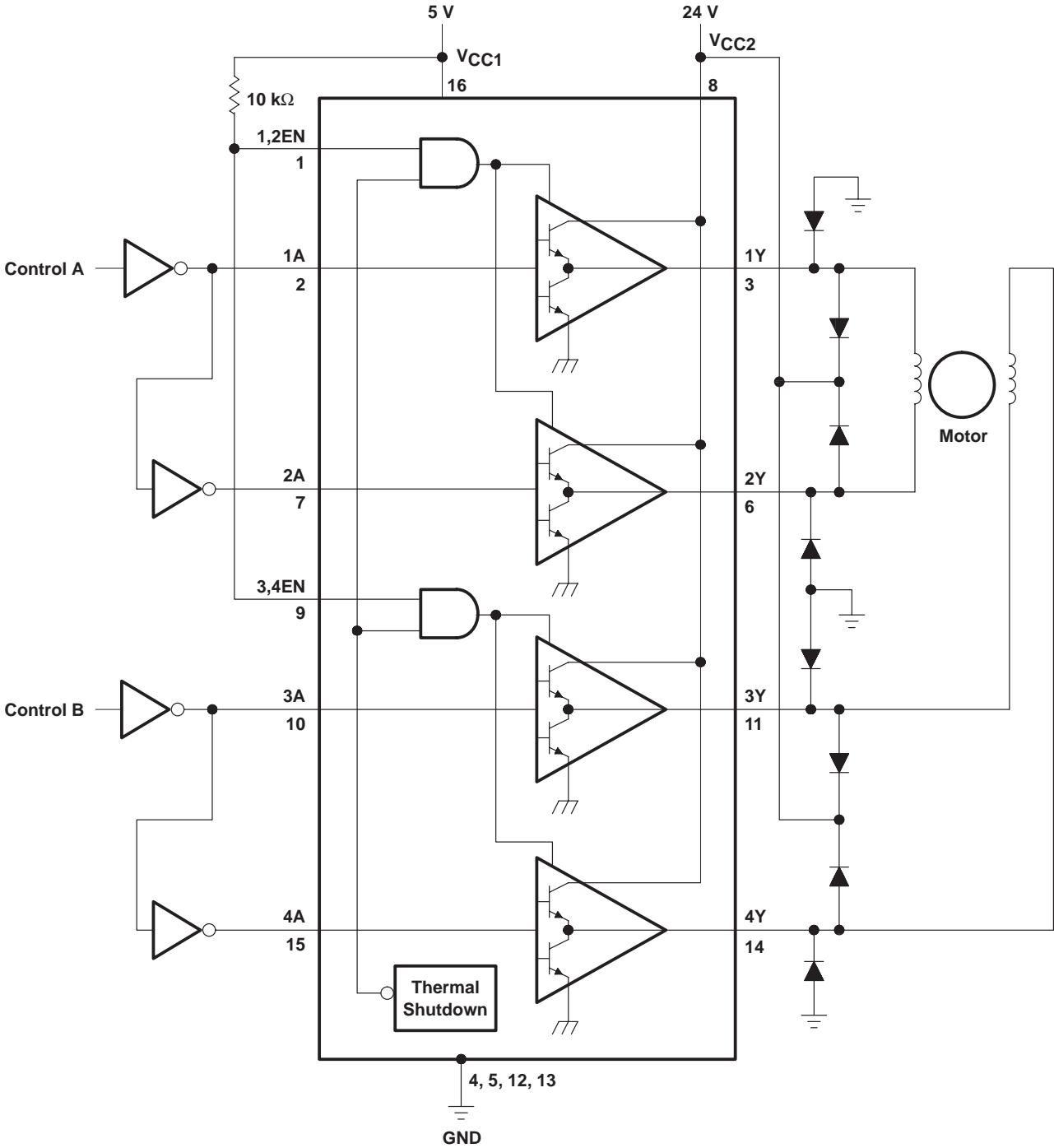

Figure 2. Two-Phase Motor Driver (L293)

L293, L293D QUADRUPLE HALF-H DRIVERS

SLRS008C – SEPTEMBER 1986 – REVISED NOVEMBER 2004

APPLICATION INFORMATION

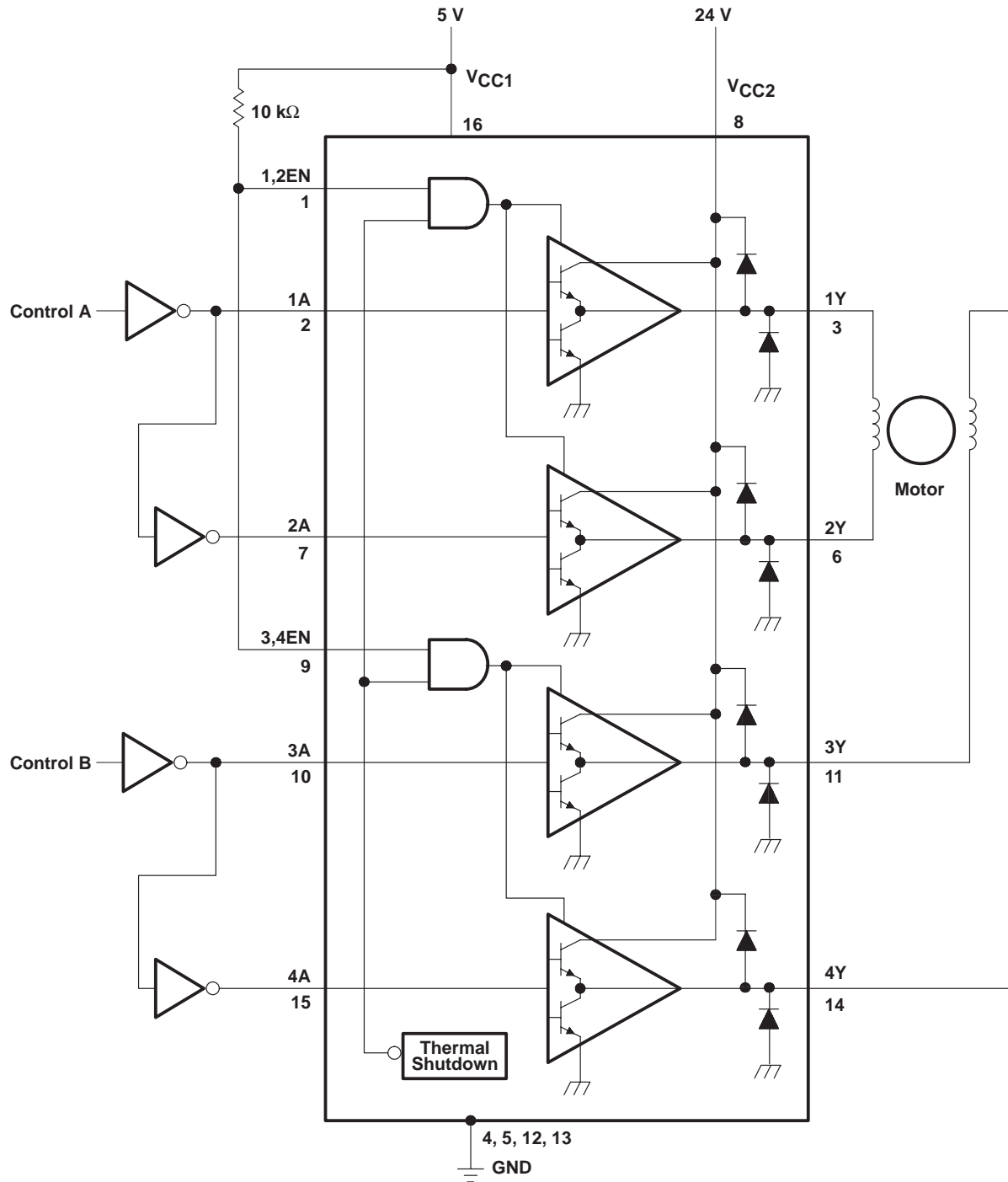
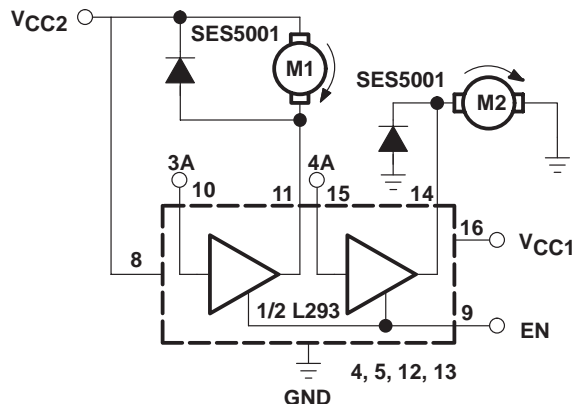

Figure 3. Two-Phase Motor Driver (L293D)

APPLICATION INFORMATION



EN	3A	M1	4A	M2
H	H	Fast motor stop	H	Run
H	L	Run	L	Fast motor stop
L	X	Free-running motor stop	X	Free-running motor stop

L = low, H = high, X = don't care

**Figure 4. DC Motor Controls
(connections to ground and to supply voltage)**

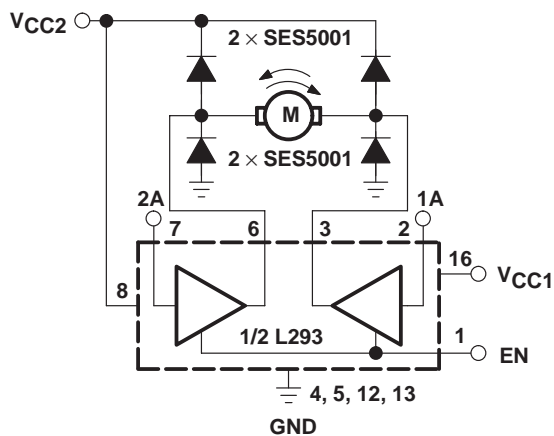

EN	1A	2A	FUNCTION
H	L	H	Turn right
H	H	L	Turn left
H	L	L	Fast motor stop
H	H	H	Fast motor stop
L	X	X	Fast motor stop

L = low, H = high, X = don't care

Figure 5. Bidirectional DC Motor Control

L293, L293D QUADRUPLE HALF-H DRIVERS

SLRS008C – SEPTEMBER 1986 – REVISED NOVEMBER 2004

APPLICATION INFORMATION

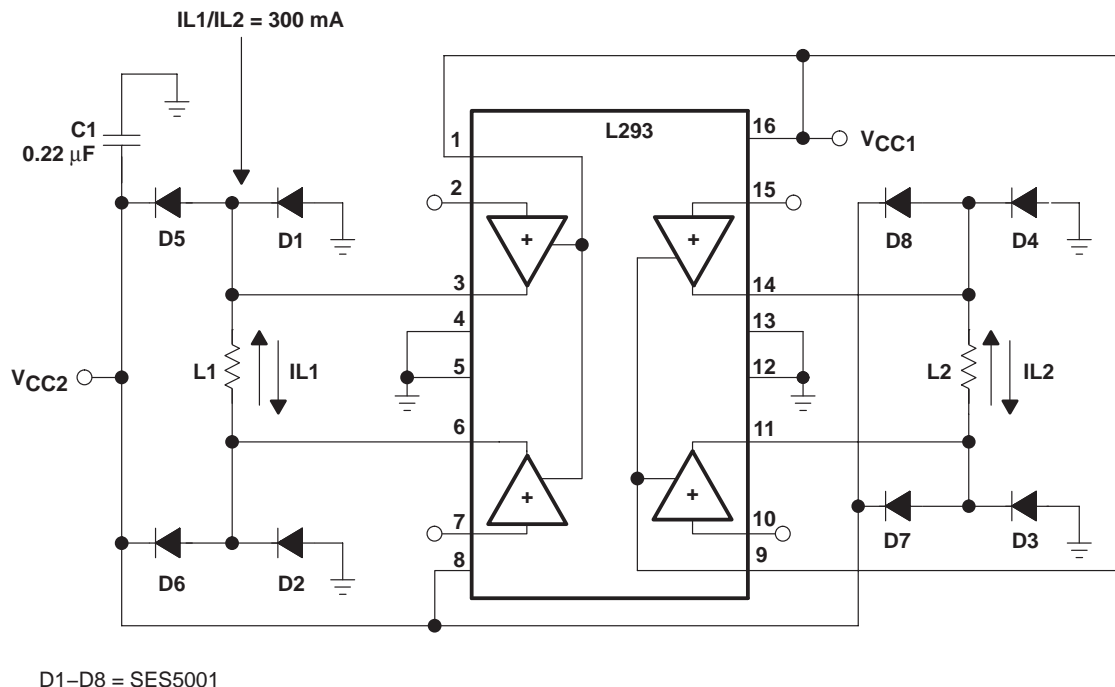

Figure 6. Bipolar Stepping-Motor Control

mounting instructions

The $R_{thj-amp}$ of the L293 can be reduced by soldering the GND pins to a suitable copper area of the printed circuit board or to an external heat sink.

Figure 9 shows the maximum package power P_{TOT} and the θ_{JA} as a function of the side l of two equal square copper areas having a thickness of $35 \mu\text{m}$ (see Figure 7). In addition, an external heat sink can be used (see Figure 8).

During soldering, the pin temperature must not exceed 260°C , and the soldering time must not exceed 12 seconds.

The external heatsink or printed circuit copper area must be connected to electrical ground.

APPLICATION INFORMATION

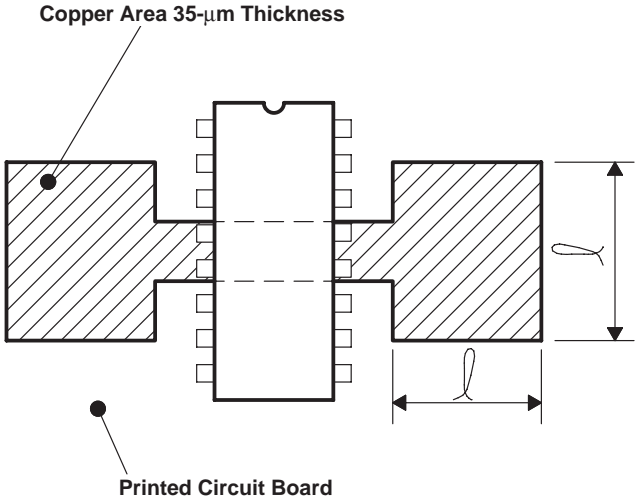

Figure 7. Example of Printed Circuit Board Copper Area (used as heat sink)

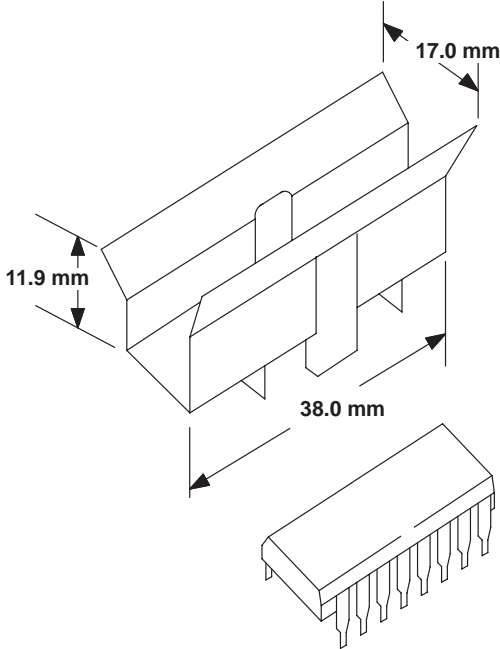

Figure 8. External Heat Sink Mounting Example ($\theta_{JA} = 25^{\circ}\text{C/W}$)

L293, L293D QUADRUPLE HALF-H DRIVERS

SLRS008C – SEPTEMBER 1986 – REVISED NOVEMBER 2004

APPLICATION INFORMATION

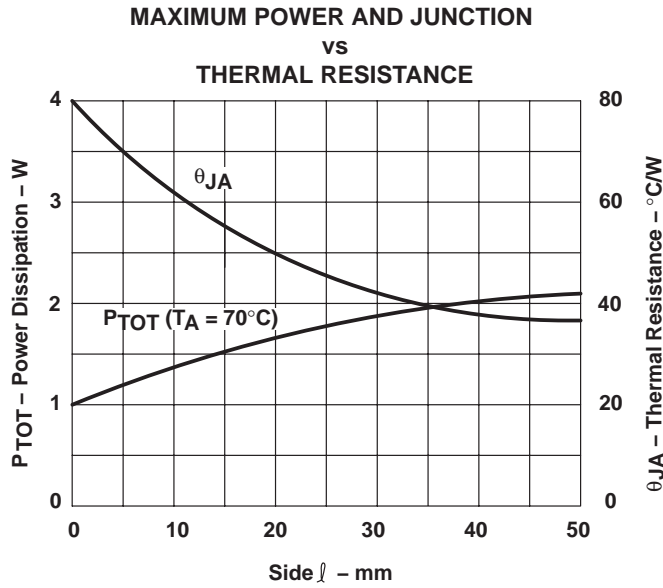

Figure 9

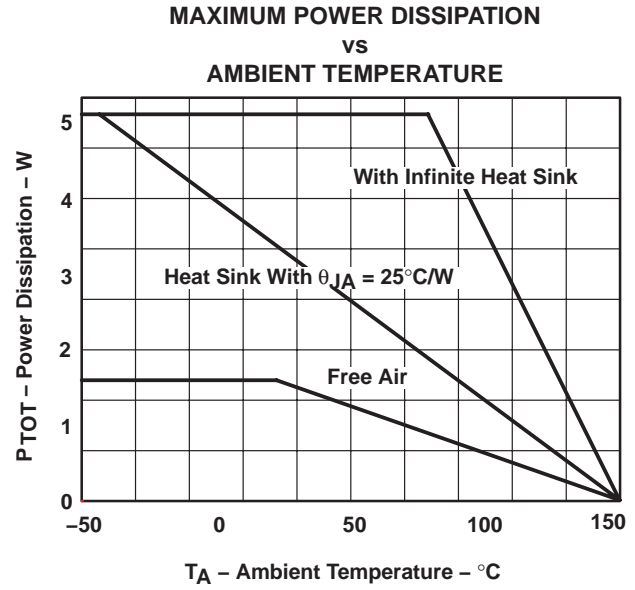

Figure 10

PACKAGING INFORMATION

Orderable Device	Status ⁽¹⁾	Package Type	Package Drawing	Pins	Package Qty	Eco Plan ⁽²⁾	Lead/Ball Finish	MSL Peak Temp ⁽³⁾
L293DDWP	OBSOLETE	SOIC	DW	28		None	CU SNPB	Level-2-220C-1 YEAR
L293DDWPTR	OBSOLETE	SOIC	DW	28		None	CU SNPB	Level-2-220C-1 YEAR
L293DN	OBSOLETE	PDIP	N	16		None	CU SNPB	Level-NA-NA-NA
L293DNE	ACTIVE	PDIP	NE	16	25	Pb-Free (RoHS)	Call TI	Level-NC-NC-NC
L293DSP	OBSOLETE			16		None	Call TI	Call TI
L293DSP883B	OBSOLETE			16		None	Call TI	Call TI
L293DSP883C	OBSOLETE		UTR			None	Call TI	Call TI
L293DWP	ACTIVE	SO Power PAD	DWP	28	20	None	Call TI	Level-2-220C-1 YEAR
L293DWPTR	OBSOLETE	SO Power PAD	DWP	28		None	Call TI	Call TI
L293N	ACTIVE	PDIP	N	16	25	None	CU SNPB	Level-NA-NA-NA
L293NE	ACTIVE	PDIP	NE	16	25	Pb-Free (RoHS)	Call TI	Level-NC-NC-NC

⁽¹⁾ The marketing status values are defined as follows:

ACTIVE: Product device recommended for new designs.

LIFEBUY: TI has announced that the device will be discontinued, and a lifetime-buy period is in effect.

NRND: Not recommended for new designs. Device is in production to support existing customers, but TI does not recommend using this part in a new design.

PREVIEW: Device has been announced but is not in production. Samples may or may not be available.

OBSOLETE: TI has discontinued the production of the device.

⁽²⁾ Eco Plan - May not be currently available - please check <http://www.ti.com/productcontent> for the latest availability information and additional product content details.

None: Not yet available Lead (Pb-Free).

Pb-Free (RoHS): TI's terms "Lead-Free" or "Pb-Free" mean semiconductor products that are compatible with the current RoHS requirements for all 6 substances, including the requirement that lead not exceed 0.1% by weight in homogeneous materials. Where designed to be soldered at high temperatures, TI Pb-Free products are suitable for use in specified lead-free processes.

Green (RoHS & no Sb/Br): TI defines "Green" to mean "Pb-Free" and in addition, uses package materials that do not contain halogens, including bromine (Br) or antimony (Sb) above 0.1% of total product weight.

⁽³⁾ MSL, Peak Temp. -- The Moisture Sensitivity Level rating according to the JEDEC industry standard classifications, and peak solder temperature.

Important Information and Disclaimer: The information provided on this page represents TI's knowledge and belief as of the date that it is provided. TI bases its knowledge and belief on information provided by third parties, and makes no representation or warranty as to the accuracy of such information. Efforts are underway to better integrate information from third parties. TI has taken and continues to take reasonable steps to provide representative and accurate information but may not have conducted destructive testing or chemical analysis on incoming materials and chemicals. TI and TI suppliers consider certain information to be proprietary, and thus CAS numbers and other limited information may not be available for release.

In no event shall TI's liability arising out of such information exceed the total purchase price of the TI part(s) at issue in this document sold by TI to Customer on an annual basis.

N (R-PDIP-T**)

PLASTIC DUAL-IN-LINE PACKAGE

16 PINS SHOWN



4040049/E 12/2002

- NOTES:
- A. All linear dimensions are in inches (millimeters).
 - B. This drawing is subject to change without notice.
 - $\triangle C$ Falls within JEDEC MS-001, except 18 and 20 pin minimum body length (Dim A).
 - $\triangle D$ The 20 pin end lead shoulder width is a vendor option, either half or full width.

NE (R-PDIP-T**)

PLASTIC DUAL-IN-LINE PACKAGE

20 PIN SHOWN

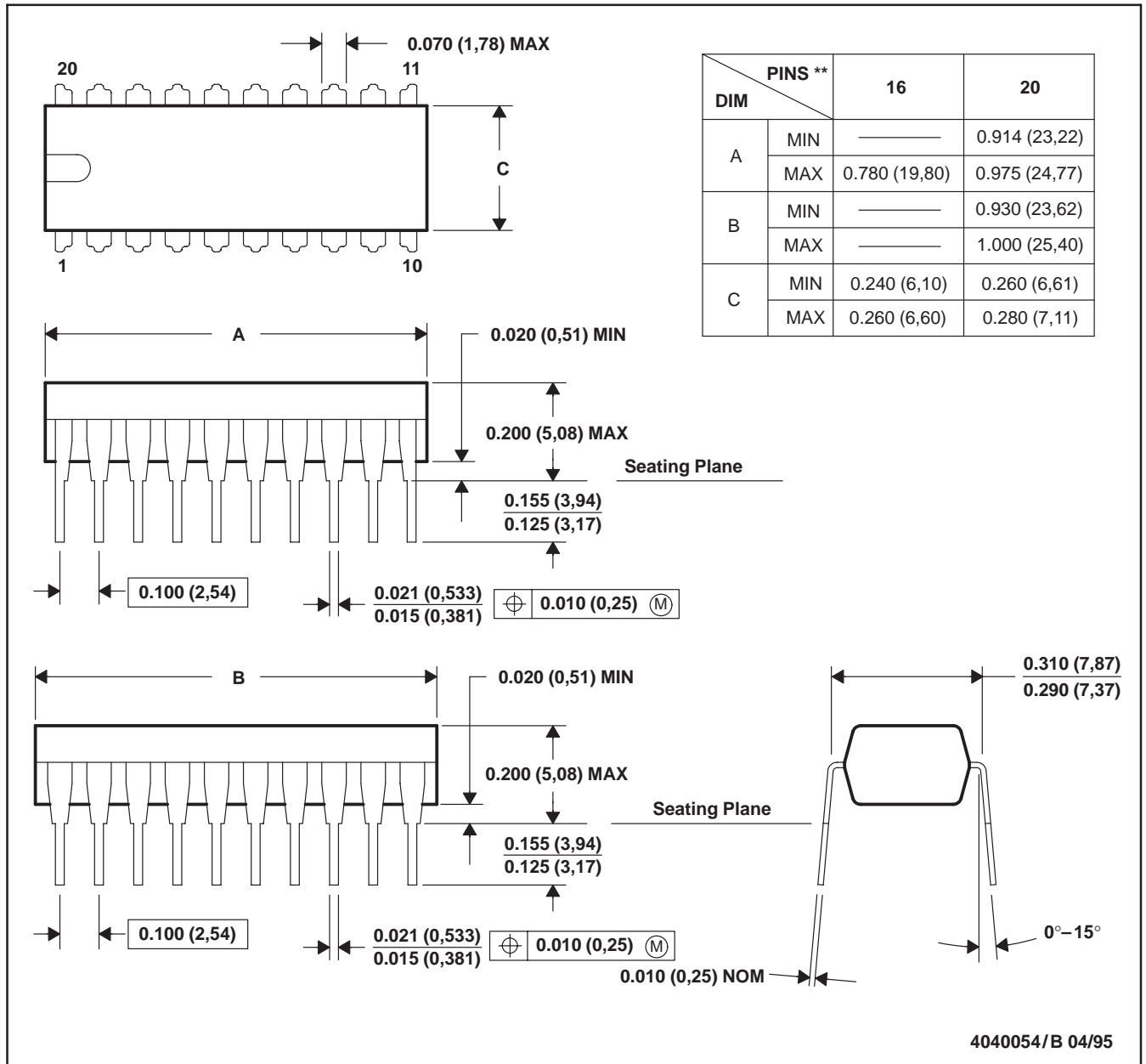

- NOTES: A. All linear dimensions are in inches (millimeters).
 B. This drawing is subject to change without notice.
 C. Falls within JEDEC MS-001 (16 pin only)

DWP (R-PDSO-G**) 20 PINS SHOWN

PowerPAD™ PLASTIC SMALL-OUTLINE PACKAGE

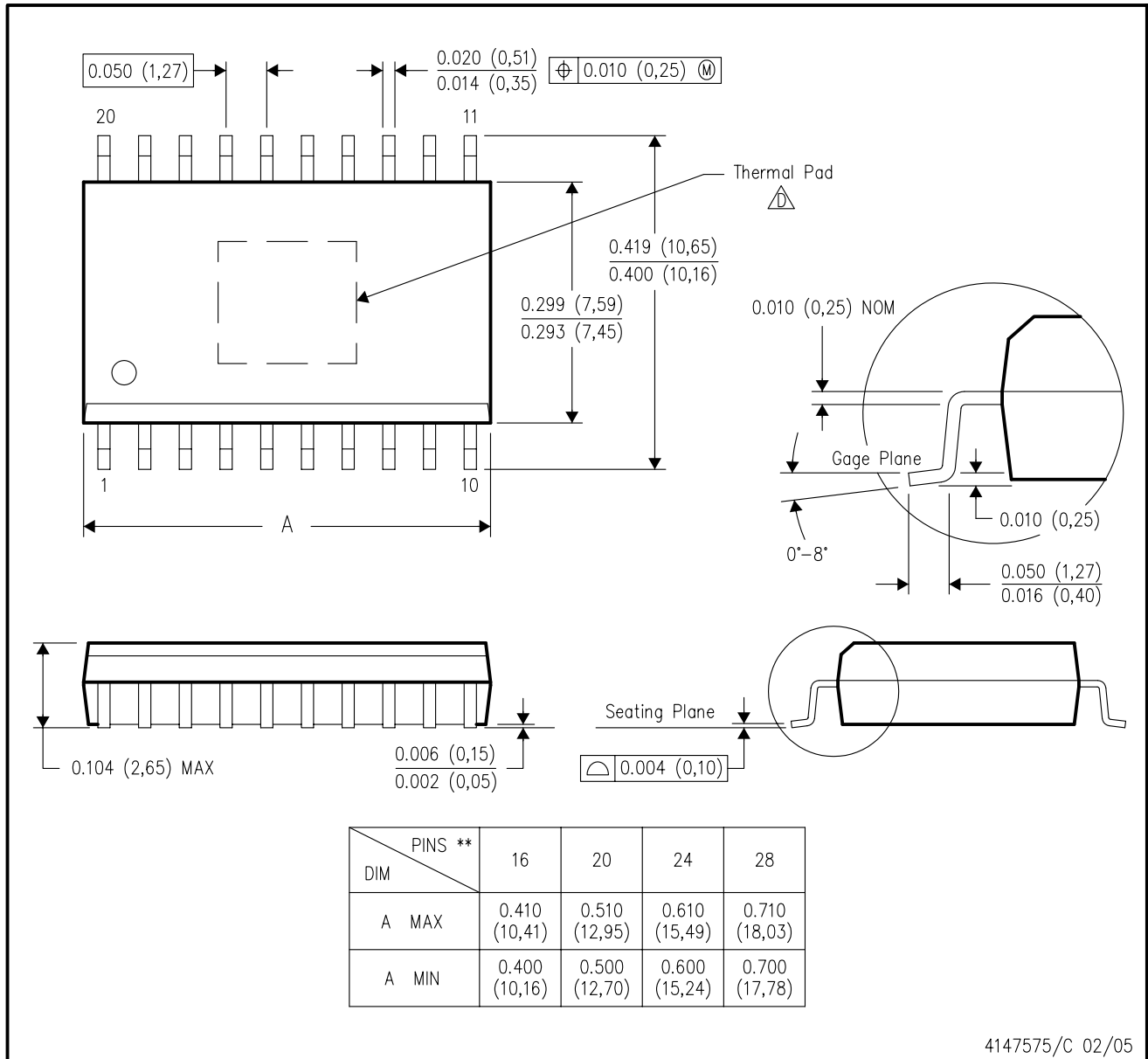

- NOTES:
- A. All linear dimensions are in inches (millimeters).
 - B. This drawing is subject to change without notice.
 - C. Body dimensions do not include mold flash or protrusion not to exceed 0.006 (0,15).
- △ This package is designed to be soldered to a thermal pad on the board. Refer to Technical Brief, PowerPAD Thermally Enhanced Package, Texas Instruments Literature No. SLMA002 for information regarding recommended board layout. This document is available at www.ti.com <<http://www.ti.com>>. See the product data sheet for details regarding the exposed thermal pad dimensions.

PowerPAD is a trademark of Texas Instruments.

DW (R-PDSO-G28)

PLASTIC SMALL-OUTLINE PACKAGE

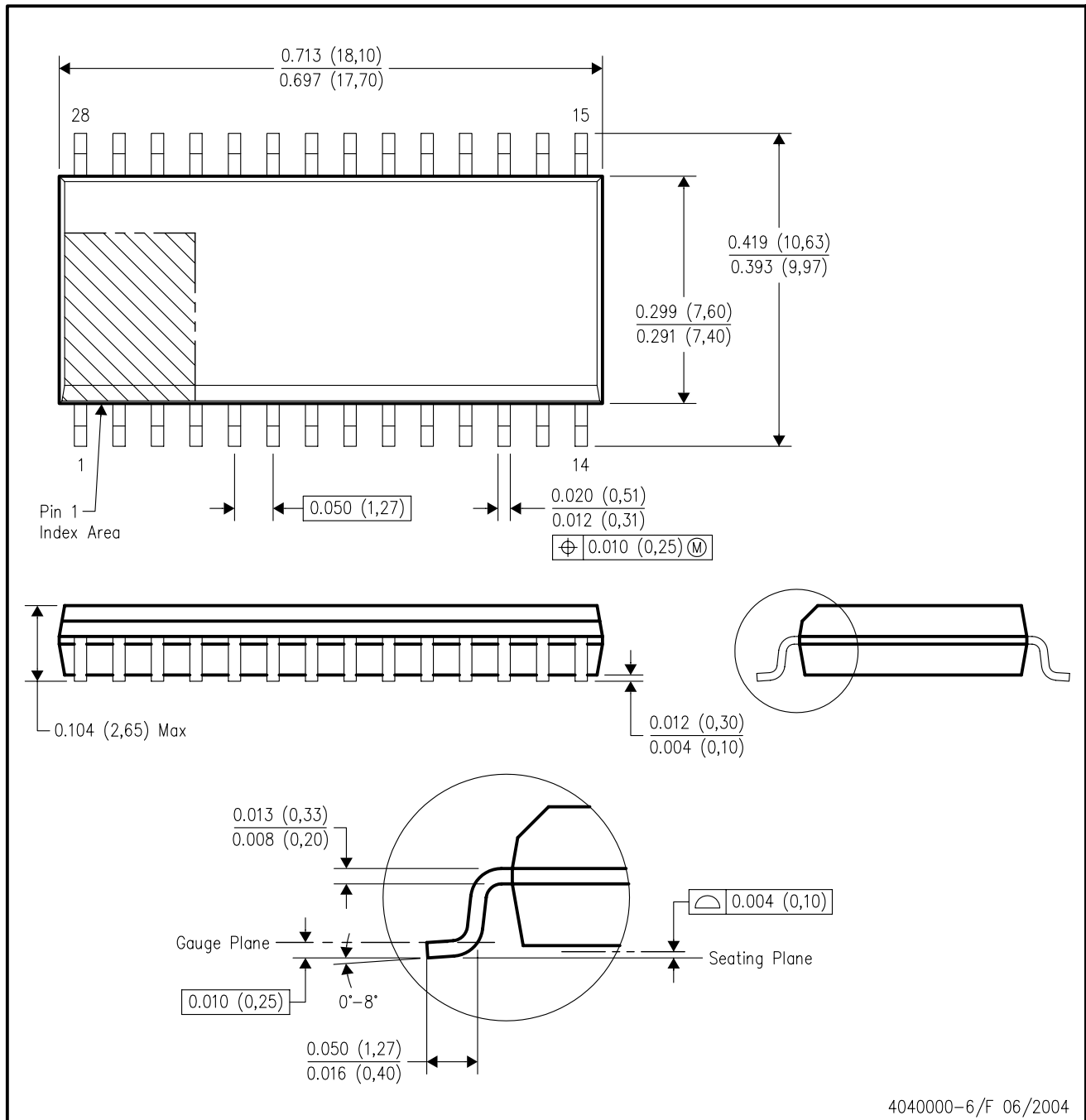

4040000-6/F 06/2004

- NOTES:
- A. All linear dimensions are in inches (millimeters).
 - B. This drawing is subject to change without notice.
 - C. Body dimensions do not include mold flash or protrusion not to exceed 0.006 (0,15).
 - D. Falls within JEDEC MS-013 variation AE.

IMPORTANT NOTICE

Texas Instruments Incorporated and its subsidiaries (TI) reserve the right to make corrections, modifications, enhancements, improvements, and other changes to its products and services at any time and to discontinue any product or service without notice. Customers should obtain the latest relevant information before placing orders and should verify that such information is current and complete. All products are sold subject to TI's terms and conditions of sale supplied at the time of order acknowledgment.

TI warrants performance of its hardware products to the specifications applicable at the time of sale in accordance with TI's standard warranty. Testing and other quality control techniques are used to the extent TI deems necessary to support this warranty. Except where mandated by government requirements, testing of all parameters of each product is not necessarily performed.

TI assumes no liability for applications assistance or customer product design. Customers are responsible for their products and applications using TI components. To minimize the risks associated with customer products and applications, customers should provide adequate design and operating safeguards.

TI does not warrant or represent that any license, either express or implied, is granted under any TI patent right, copyright, mask work right, or other TI intellectual property right relating to any combination, machine, or process in which TI products or services are used. Information published by TI regarding third-party products or services does not constitute a license from TI to use such products or services or a warranty or endorsement thereof. Use of such information may require a license from a third party under the patents or other intellectual property of the third party, or a license from TI under the patents or other intellectual property of TI.

Reproduction of information in TI data books or data sheets is permissible only if reproduction is without alteration and is accompanied by all associated warranties, conditions, limitations, and notices. Reproduction of this information with alteration is an unfair and deceptive business practice. TI is not responsible or liable for such altered documentation.

Resale of TI products or services with statements different from or beyond the parameters stated by TI for that product or service voids all express and any implied warranties for the associated TI product or service and is an unfair and deceptive business practice. TI is not responsible or liable for any such statements.

Following are URLs where you can obtain information on other Texas Instruments products and application solutions:

Products		Applications	
Amplifiers	amplifier.ti.com	Audio	www.ti.com/audio
Data Converters	dataconverter.ti.com	Automotive	www.ti.com/automotive
DSP	dsp.ti.com	Broadband	www.ti.com/broadband
Interface	interface.ti.com	Digital Control	www.ti.com/digitalcontrol
Logic	logic.ti.com	Military	www.ti.com/military
Power Mgmt	power.ti.com	Optical Networking	www.ti.com/opticalnetwork
Microcontrollers	microcontroller.ti.com	Security	www.ti.com/security
		Telephony	www.ti.com/telephony
		Video & Imaging	www.ti.com/video
		Wireless	www.ti.com/wireless

Mailing Address: Texas Instruments
Post Office Box 655303 Dallas, Texas 75265