

# KMI23/2; KMI23/4

High performance rotational speed sensor

Rev. 1 — 28 April 2016

Product data sheet

## 1. Product profile

### 1.1 General description

Based on the Anisotropic MagnetoResistive (AMR) effect, the KMI23/2 and the KMI23/4 detect the rotational speed of target wheels. The KMI23/2 is used with active target wheels (multipole encoders) and the KMI23/4 is used with passive target wheels (ferromagnetic gear wheels). This design delivers secure speed information over a wide range of speed, air gap and temperature. It delivers the speed information via a current protocol at the supply pins.

#### CAUTION



Do not press two or more products together against their magnetic forces and do not let them collide with each other.

### 1.2 Features and benefits

- System in package
- Two wire current interface
- Square wave output signal (standard protocol)
- Large range of air gap
- Large range of operating terminal voltage
- Wide temperature range
- High ElectroStatic Discharge (ESD) protection
- Very low jitter
- Automotive qualified in accordance with AEC-Q100 Rev-G (grade 0)



## 1.3 Quick reference data

Table 1. Quick reference data

Symbol	Parameter	Conditions	Min	Typ	Max	Unit
V <sub>CC</sub>	supply voltage	normal operation mode; T <sub>amb</sub> ≤ 170 °C; referred to pin GND	6.8	-	16	V
T <sub>amb</sub>	ambient temperature	normal operation mode	-40	-	+150	°C
I <sub>CCL</sub>	LOW-level supply current		5.88	7.0	8.4	mA
I <sub>CCH</sub>	HIGH-level supply current		11.7	14.0	16.8	mA
f <sub>H</sub>	magnetic field strength frequency		0	-	2.5	kHz
H <sub>M</sub>	peak magnetic field strength	after power-on; speed pulses latest after N <sub>cy(H)</sub> magnetic cycles; see characteristics in <a href="#">Table 6</a>				
		KMI23/2	150	-	-	A/m
		KMI23/4	190	-	-	A/m

## 2. Pinning information

Table 2. Pinning

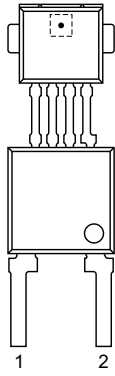
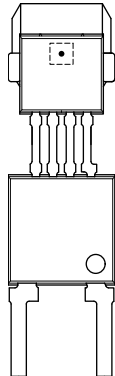
Pin	Symbol	Description	Simplified outline	
			KMI23/2	KMI23/4
1	V <sub>CC</sub>	supply pin		
2	GND	ground pin		

## 3. Ordering information

Table 3. Ordering information

Type number	Package		
	Name	Description	Version
KMI23/2	SIP2	plastic single-ended multi-chip package; magnetized ferrite magnet (3.8 × 2 × 0.8 mm); 4 interconnections; 2 in-line leads	SOT453A
KMI23/4	SIP2	plastic single-ended multi-chip package; magnetized ferrite magnet (4.25 × 5.2 × 3 mm); 4 interconnections; 2 in-line leads	SOT453E

## 4. Functional diagram

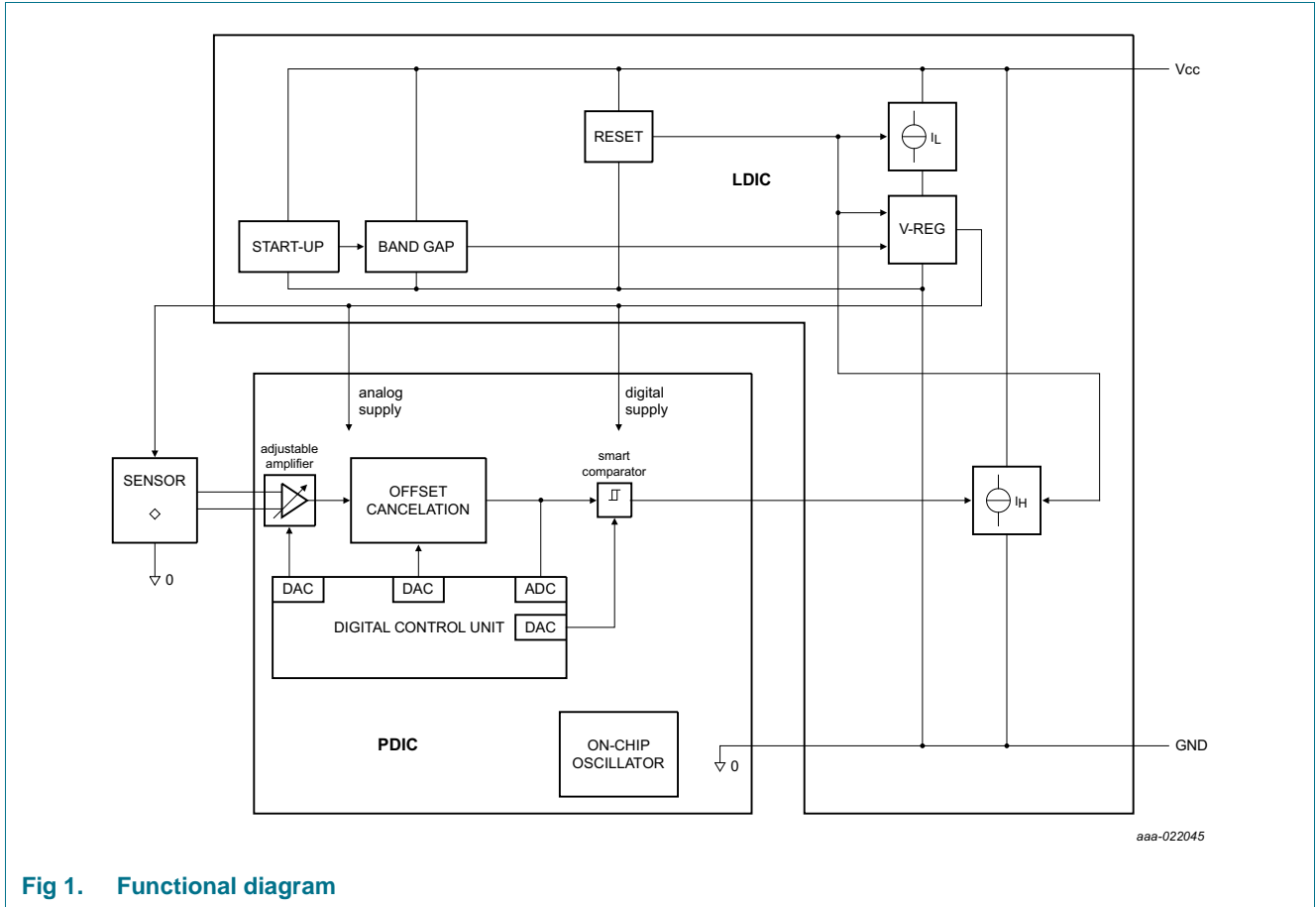

Fig 1. Functional diagram

## 5. Functional description

The KMI23/2 and the KMI23/4 are high performance AMR speed sensors, which are dedicated to ABS applications. The difference between both product versions is the stimulating element in the application, which is a magnetized multipole encoder (KMI23/2) or a ferromagnetic gear wheel (KMI23/4).

### 5.1 System architecture

The functional principles of KMI23/2 and KMI23/4 are shown in [Figure 2](#) and [Figure 3](#), respectively. For the KMI23/2, the magnetic poles lead to different magnetic stimuli at the AMR bridge. For the KMI23/4, flux bending at the gear wheel teeth generates different magnetic stimuli at the AMR bridge. In both cases, the electrical output voltage of the AMR bridge depends on the position of the sensor relative to the encoder. As a consequence, a rotating encoder generates a periodic output signal at the AMR bridge. The KMI23/2 and the KMI23/4 are sensitive to movement in the y direction in front of the sensor only. For definition of the coordinate axes, see [Figure 4](#).

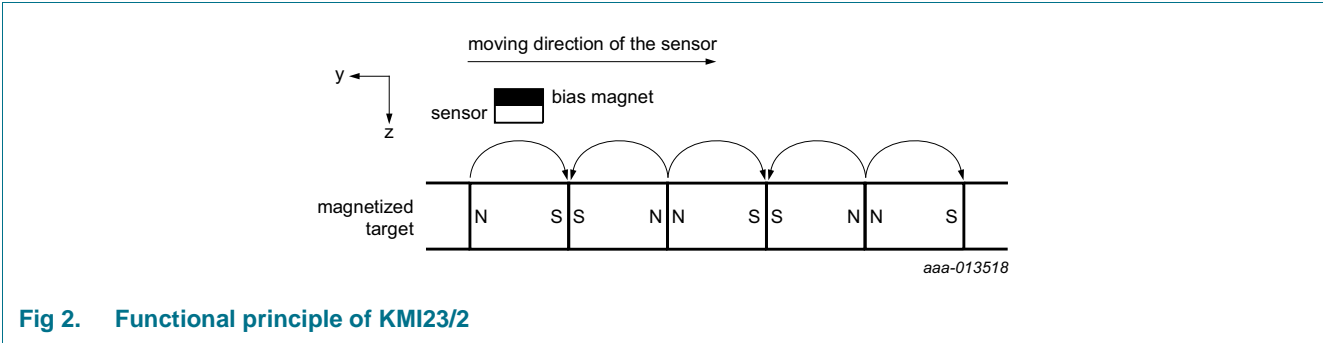

Fig 2. Functional principle of KMI23/2

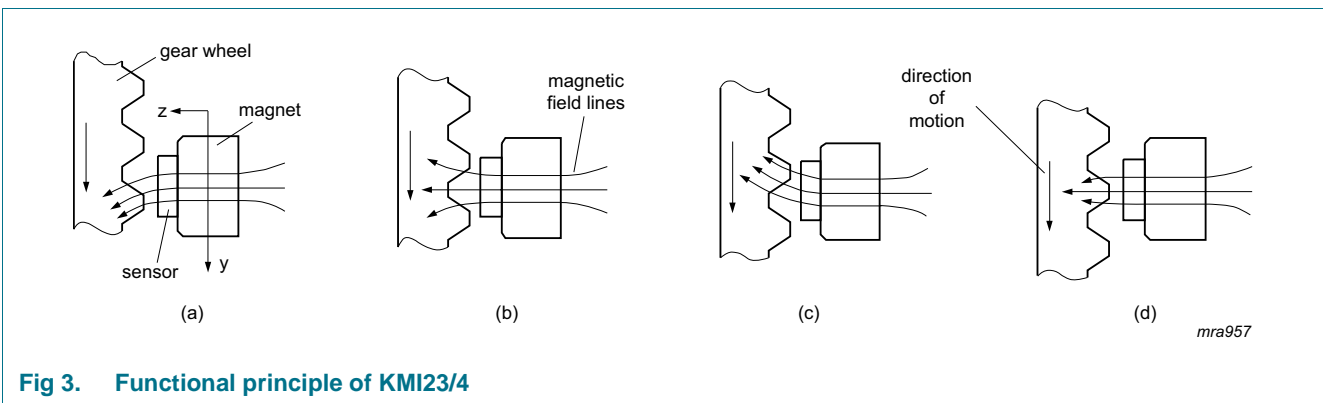

Fig 3. Functional principle of KMI23/4

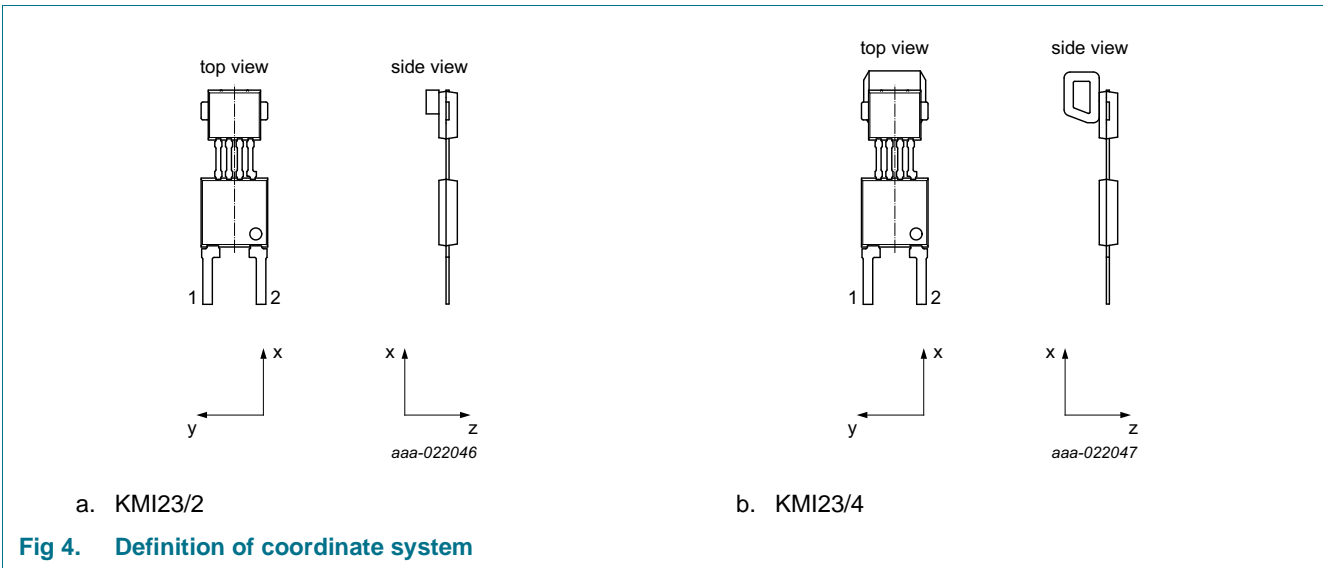

Fig 4. Definition of coordinate system

The KMI23/2 and the KMI23/4 each comprise an AMR sensor chip, a Position Detector IC (PDIC) and a Line Driver IC (LDIC). The PDIC comprises the signal conditioning circuits, whereas the LDIC comprises the external interface and the supply for PDIC and AMR bridge (see Figure 1). The AMR sensor chip carries four MR elements arranged as a Wheatstone bridge. The AMR bridge converts the magnetic field, generated by the encoder rotation, into an electrical output signal. This signal is nearly sinusoidally with time.

The LDIC chip is fabricated using a robust high-voltage process. This measure shields the other two dies from the harsh electrical environment on the supply line  $V_{CC}$ . The constant current source  $I_L$  provides the LOW-level output signal of typically 7 mA and delivers the supply current for the whole sensor system. Thus from  $I_L$  the supply voltages for the PDIC, the AMR bridge and the current source block  $I_H$  are derived. The switchable current source  $I_H$  also delivers typically 7 mA. Hence, if  $I_H$  is active, the total supply current is at its HIGH level of typically 14 mA. With this current interface, safe sensor signal transport to the Electronic Control Unit (ECU) using only a two-wire cable is provided.

Within the PDIC, the differential output voltage of the AMR sensor bridge leads as speed signal into an analog signal chain. It comprises an amplifier with adjustable gain, followed by an offset cancelation stage and finally, a smart comparator having adjustable hysteresis levels. The latter converts the sinusoidal sensor signal into a rectangular output signal, which controls the switchable current source  $I_H$ . Hence, the supply current switches between its LOW and HIGH values of typically 7 mA and 14 mA at the magnetic field strength frequency. Thus, the supply current as an output signal allows measuring the rotational speed of the encoder wheel.

A peak detector within the digital control unit on the PDIC measures the amplitude and the offset of the sensor signal. The peak detector has a resolution of 8 bit. This feature allows the digital control unit on one hand, to eliminate the signal offset. This function is realized with a dedicated Digital-to-Analog Converter (DAC). The DAC has a resolution of 12 bits. On the other hand, it allows the digital control unit to optimize amplifier gain and comparator hysteresis settings according to the actual signal amplitude. Due to these measures, the sensor system can handle a wide amplitude range. This amplitude range in turn allows the KMI25/2 and KMI25/4 to handle a wide range of air gaps between sensor and encoder. The hysteresis of the smart comparator prevents erroneous multiple switching due to mechanical vibrations of the encoder wheel. A further important feature of the smart comparator is, that it switches its output level always at the zero-crossing of its input signal. Thus, the phase of its rectangular output signal is independent of its hysteresis setting and independent of the gain setting at the amplifier. For this reason, adjustments of gain and hysteresis in the signal chain avoid the introduction of jitter into the sensor output signal. The whole signal chain works even under DC conditions, therefore having true zero Hertz capability.

## 5.2 Speed signal conditioning algorithm

The digital control unit (see [Figure 1](#)) controls the speed signal conditioning algorithm. The general purpose is, to control the analog blocks in the signal channel to optimize signal conditions at the analog comparator input. Therefore, the algorithm characterizes the sensor input signal, as observed within the digital domain. As a result, the algorithm adjusts the amplifier gain, cancels the signal offset and sets the comparator hysteresis. To fulfill this task, the digital control unit provides switching between different operating modes. Depending on frequency and amplitude of the input signal, one of the following modes is selected:

- Start-up mode
- Adaptation mode
- Normal mode
- Low-speed mode

Figure 5 depicts a flow chart summarizing the most important features of each mode and the conditions for switching between modes. For each transition, all of the listed conditions must be satisfied (logical AND), unless the notation 'or' is used. The latter indicates a logical OR connection. In this case, the transition is performed if any of the listed conditions is satisfied.

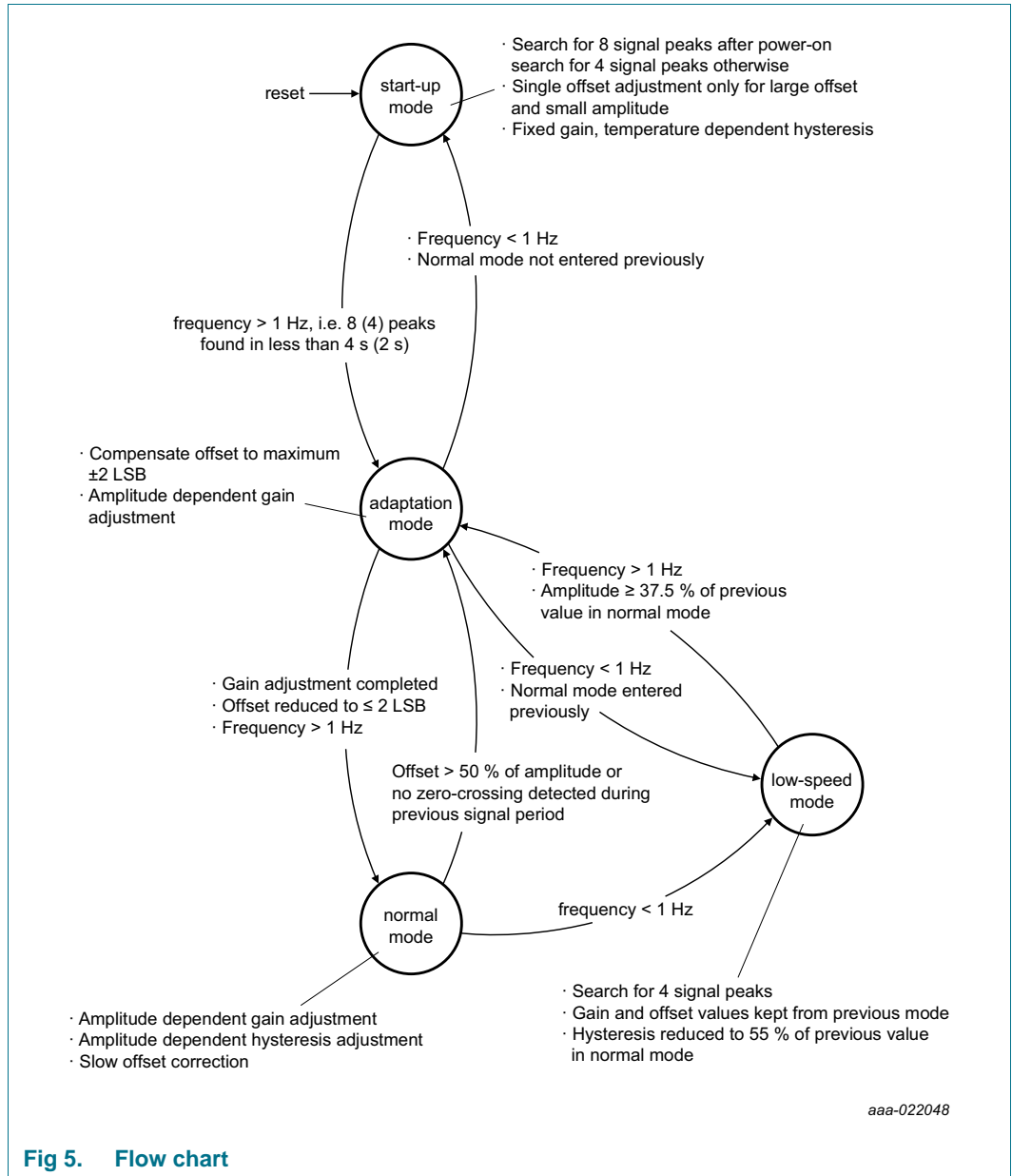

Fig 5. Flow chart

The following sections describe the implemented measurement functions for offset, amplitude and frequency as well as each operation mode.

### 5.2.1 Peak detector

The peak detector is part of the digital control unit. It samples the AMR input signal with a resolution of 8 bits and detects the positive and negative peak values. From these values, it calculates the signal offset and the signal amplitude. The offset is calculated as half of

the sum of opposite signal peaks. The amplitude is calculated as difference of opposite signal peaks. Principally, a peak is detected, where the difference between succeeding signal samples switches its sign. In order to cope with superimposed noise and spurious spikes, the peak detector uses dedicated filter algorithms.

### 5.2.2 Frequency measurement

As pointed out above, the peak detector calculates the signal offset. This offset level is the 'zero level' of the sensor signal. Whenever the sensor signal crosses this 'zero level', the comparator switches its state.

If a zero-crossing with a falling edge is detected first, then frequency measurements are always made between falling edges. If a zero-crossing with a rising edge is detected first, then frequency measurements are always made between rising edges. Thus always a complete signal period is used and the result is independent of any duty cycle shifts.

The frequencies occurring in start-up mode and low-speed mode are very low. Thus, an indirect frequency measurement is done here by counting the number of signal peaks within 2 seconds.

### 5.2.3 Start-up mode

Usually the system enters this mode after power-on reset. At power-on, nothing is known about the input signal properties. The function of the speed control algorithm in start-up mode is to characterize the input signal and produce estimates of its amplitude, offset and frequency. Therefore, once the sensor element has been supplied with voltage, all circuit parts are set into defined initial conditions. These conditions comprise fixed amplifier gain and fixed (but temperature-dependent) comparator hysteresis. Furthermore, there is still no offset cancelation. This procedure may take up to 1 ms. These initial conditions are used to process the sensor bridge signal in the first instant. Thereafter the system is ready to react on the input voltage.

If the first speed signal samples are near the positive or negative signal range limit, a large offset is assumed. In this case, an initial offset correction with a predefined level is executed. This function is applied to speed up the signal recognition in case of small signals superimposed on a large offset.

Generally, the 'start-up' performance strongly depends on the signal amplitude and its offset. Because of the possibility of missing the second zero-crossing, the first zero-crossing of the input signal is not used. So under normal conditions (offset is relatively small w.r.t. amplitude), the sensor issues the first speed pulse at its output with the second zero-crossing of the analog input signal. As there is no offset regulation during start-up mode, the speed pulses issued during this mode may be shifted in time w.r.t. the zero-crossings of the sensor signal. As a consequence, the duty cycle of the output signal may not yet fulfill the specification, if an external magnetic offset is present. For small amplitudes and large offsets, no zero-crossings may be detected during start-up mode until offset compensation is performed in adaptation mode.

If the peak detector has found 8 signal peaks within 4 seconds, start-up mode is left and adaptation mode is entered. However, if start-up mode has been entered coming from adaptation mode, then 4 signal peaks within 2 seconds cause reentering adaptation mode.

### 5.2.4 Adaptation mode

The main purpose of adaptation mode is to optimize the signal conditions by adjusting gain and offset, based on the estimates made in start-up mode. After standstill or in a sudden change of signal offset, adaptation mode is entered as well.

In adaptation mode, offset compensation and gain setting are applied once per signal cycle. Offset compensation first takes place in correcting  $\frac{7}{8}$  of the calculated offset per step. It continues until the residual offset is below a threshold of 2 Least Significant Bit (LSB). An exception occurs, if the remaining offset is larger than five times the signal amplitude. In this case, the correction of that step is limited to the remaining offset level.

In order to avoid the generation of erroneous additional zero-crossings, the activity of the offset compensation depends on the previous signal slope. Therefore, a positive offset is only corrected after a falling slope and a negative offset is only corrected after a rising slope.

If necessary, the amplifier gain is doubled or halved, until the digital signal amplitude is between 25 % and 75 % of its range. The temperature-dependent hysteresis level at the comparator input is kept at the same percentage level w.r.t. to the signal range as in the previous mode.

The number of steps required for the adaptation process depends on the relation between offset and signal amplitude. Small amplitudes coming with a large offset require a maximum number of steps. In such cases, the first zero-crossing may not be detected in start-up mode, but in adaptation mode. As in start-up mode the second zero-crossing could be missed under certain conditions also in adaptation mode. Therefore, in order to ensure an uninterrupted pulse train, also in adaptation mode the first detected zero-crossing is not used. Hence under normal conditions, the first output signal is issued at the second detected zero-crossing.

The goal of the adaptations is a signal amplitude of 25 % to 75 % and an offset of maximal 2 LSB. If the frequency is greater than 1 Hz, the system then switches from adaptation mode to normal mode. If the frequency falls below 1 Hz, the previous mode is entered again (start-up mode or low-speed mode).

### 5.2.5 Normal mode

Normal mode is entered when the necessary adjustments to the gain and offset have been completed in adaptation mode. The goal of the normal mode is, to keep duty cycle and jitter of the output signal within specification.

During normal mode, amplifier gain is still adapted proportional to signal amplitude as in adaptation mode. Thus, the input signal amplitude is between 25 % and 75 % of the signal range. The hysteresis control, which in start-up mode and adaptation mode is carried out depending on temperature, is now carried out depending on signal amplitude. Applied hysteresis levels are at 23 % to 52 % of the amplitude. Due to this measure, the hysteresis levels are high enough to provide a high level of immunity to noise and signal disturbances. On the other hand, the hysteresis is small enough to maintain continued comparator switching, even when offset jumps occur. For very small amplitudes, the hysteresis is not set below a fixed minimum level and the ratio hysteresis/amplitude can become greater than 52 %.



In adaptation mode, the offset has been reduced down to maximum 2 LSB using few coarse compensation steps. In normal mode however, the goal is to reach and maintain zero offset by using a slow offset correction. For this purpose, the offset compensation level is changed at a limited rate versus time, as long as a residual offset is detected. Due to this slow offset correction, duty cycle deviations and jitter of succeeding output pulses are minimized. If however offset changes at a faster rate than the slow correction can compensate, an increasing residual offset occurs. The residual offset causes a shift of the duty cycle  $\delta_o$  at the output signal. In order to prevent  $\delta_o$  from leaving the specified window (see characteristics in [Table 6](#)) or even loss of signal, the system switches back to adaptation mode. If the residual offset has become greater than 50 % of the amplitude, the system switches to adaptation mode. In adaptation mode, the remaining offset is minimized again, as described in [Section 5.2.4](#).

If the signal frequency drops below 1 Hz, the system also leaves normal mode and enters low-speed mode.

### 5.2.6 Low-speed mode

If during adaptation mode or normal mode, the frequency drops below 1 Hz low-speed mode is entered. If the vehicle is stationary, no signal peaks can be detected in order to calculate amplitude and offset. Thus, the algorithms for offset compensation and adaptation of gain and hysteresis cannot be applied. Therefore, low-speed mode acts as a standby mode. In this mode, some of the normal functions of the algorithms are suspended until the frequency returns above 1 Hz.

The previously calculated offset and gain setting are maintained, until the system returns to adaptation mode. The hysteresis thresholds of the comparator are lowered to 55 % of their previous value (if not the lowest hysteresis was already present). This measure allows an amplitude reduction up to 44 % without loss of comparator switching.

A special case is 'signal clipping' during low-speed mode. Signal clipping means, that the sensor signal reaches the positive or negative edge of the signal range. In this case, slow offset compensation, similar to normal mode is applied. The goal of this measure is to prevent, that the offset drift moves the full signal outside of the signal range.

The system leaves low-speed mode and enters adaptation mode as soon as the peak detector has found four signal peaks within two seconds. As an additional condition, the signal amplitude must be greater than 37.5 % of the value measured when entering low-speed mode.

## 5.3 Output signal

### 5.3.1 Physical representation of output signal

The output signal is shown in [Figure 6](#). Whenever there is a zero-crossing of the magnetic input field (falling or rising) the output current changes from 7 mA to 14 mA or vice versa. Between the detected zero-crossing and the respective edge of the output current, there is a delay time of  $t_d$  (see characteristics in [Table 6](#)).

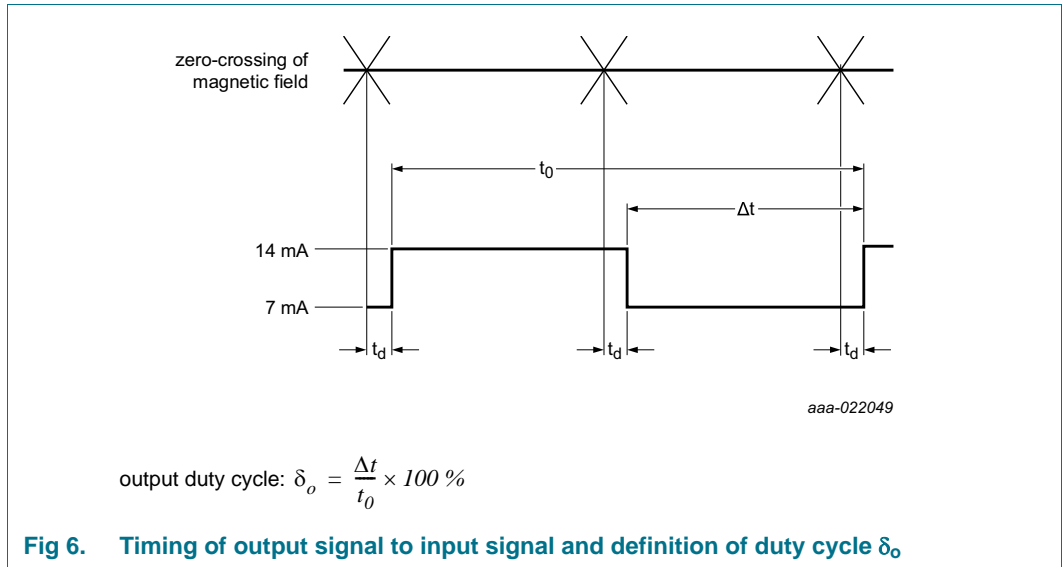

## 6. Limiting values

**Table 4. Limiting values**

In accordance with the Absolute Maximum Rating System (IEC 60134). Voltages are referred to pin GND.

Symbol	Parameter	Conditions	Min	Max	Unit
V <sub>CC</sub>	supply voltage	normal operation mode			
		-40 °C < T <sub>amb</sub> < +60 °C; t < 2 minutes	-	24	V
		-40 °C < T <sub>amb</sub> < +60 °C	-	18	V
		-40 °C < T <sub>amb</sub> < +150 °C	-	16	V
		150 °C < T <sub>amb</sub> < 175 °C; 10 × 10 minutes during total life time; none destructive but no functionality granted	-	16	V
	V <sub>CC</sub> and GND incidentally swapped	-16.5	-	V	
T <sub>amb</sub>	ambient temperature		-40	+150	°C
		for 10 × 10 minutes during total life time; V <sub>CC</sub> < 16 V	-40	+175	°C
T <sub>stg</sub>	storage temperature	no voltage applied	-50	+150	°C
T <sub>sld</sub>	soldering temperature	for maximum 5 s	-	260	°C
H <sub>ext</sub>	external magnetic field strength		-	30	kA/m

## 7. Recommended operating conditions

**Table 5. Operating conditions**

Voltages are referred to pin GND.

Symbol	Parameter	Conditions	Min	Max	Unit
V <sub>CC</sub>	supply voltage	normal operation mode; T <sub>amb</sub> ≤ 175 °C	6.8	16	V
R <sub>L</sub>	load resistance		-	50	Ω
T <sub>amb</sub>	ambient temperature	normal operation mode	-40	+150	°C
f <sub>H</sub>	magnetic field strength frequency		0	2.5	kHz
H <sub>M</sub>	peak magnetic field strength	after power-on; speed pulses latest after N <sub>cy(H)</sub> magnetic cycles; see characteristics in <a href="#">Table 6</a>			
		KMI23/2	150	-	A/m
		KMI23/4	190	-	A/m
H <sub>offset(ext)</sub>	external magnetic field strength offset (absolute value)	to allow correct start-up after power-on			
		KMI23/2	-	528	A/m
		KMI23/4	-	911	A/m
ΔH <sub>M</sub>	peak magnetic field strength variation	allowable sudden change of magnetic signal peak level without loss of speed pulses			
		non-recurring changes	-40	+100	%
		periodic changes	-10	+10	%

## 8. Characteristics

**Table 6. Characteristics**

Characteristics are valid for the operating conditions specified in [Section 7](#); voltages are referred to pin GND; unless otherwise specified.

Symbol	Parameter	Conditions	Min	Typ	Max	Unit
<b>Supply voltage and current</b>						
V <sub>CC(swon)</sub>	switch-on supply voltage		<a href="#">[1]</a> 5.8	6.3	6.8	V
t <sub>d(on)</sub>	turn-on delay time		<a href="#">[2]</a> -	-	1	ms
V <sub>CC(swoff)</sub>	switch-off supply voltage		<a href="#">[1]</a> 4.0	4.5	5.0	V
V <sub>CC(hys)</sub>	supply voltage hysteresis	switch-on/switch-off	1.6	1.8	2.8	V
I <sub>CC(swoff)</sub>	switch-off supply current	V <sub>CC</sub> < 4 V	1.0	3.0	3.8	mA
I <sub>CCL</sub>	LOW-level supply current		5.88	7.0	8.4	mA
I <sub>CCH</sub>	HIGH-level supply current		11.7	14.0	16.8	mA
I <sub>CCH</sub> /I <sub>CCL</sub>	HIGH-level supply current to LOW-level supply current ratio		1.8	2.0	-	-
di <sub>CC</sub> /dt	rate of change of supply current	I <sub>CCL</sub> to I <sub>CCH</sub> and I <sub>CCL</sub> to I <sub>CCM</sub> (10 % to 90 % and 90 % to 10 %)	6	-	28	mA/μs

**Table 6. Characteristics ...continued**

Characteristics are valid for the operating conditions specified in [Section 7](#); voltages are referred to pin GND; unless otherwise specified.

Symbol	Parameter	Conditions	Min	Typ	Max	Unit
<b>Timing parameters</b>						
$t_d$	delay time	delay between magnetic zero-crossing and output switching; see <a href="#">Figure 6</a>	70	-	121	$\mu$ s
$\sigma(T)$	period jitter	one-sigma value; required peak level of magnetic signal: $H_M = 280$ A/m (KMI23/2) $H_M = 398$ A/m (KMI23/4)	-0.1	-	+0.1	%
		one-sigma value; required peak level of magnetic signal: $H_M = 55$ A/m (KMI23/2) $H_M = 78$ A/m (KMI23/4)	-0.5	-	+0.5	%
$\delta_o$	output duty cycle	required peak level of magnetic signal: $H_M = 55$ A/m (KMI23/2) $H_M = 78$ A/m (KMI23/4)	[3] 30	-	70	%
		required peak level of magnetic signal: $H_M = 75$ A/m (KMI23/2) $H_M = 107$ A/m (KMI23/4)	[3] 40	-	60	%
<b>Start-up performance after power-on, if magnetic field amplitude &gt; minimum value of <math>H_M</math> and <math>f_H &gt; 1</math> Hz</b>						
$N_{cy(H)}$	number of magnetic field cycles	no external magnetic offset; duty cycle within specification	-	-	15	-
		maximum allowed external magnetic offset; duty cycle within specification	-	-	23	-

- [1] Once  $V_{CC}$  has exceeded  $V_{CC(swon)}$ , the sensor switches on and current levels and current ratios are maintained until  $V_{CC}$  falls below  $V_{CC(swoff)}$ .
- [2] After supplying more than  $V_{CC(swon)}$  to the device, it needs a turn-on delay time of  $t_{d(on)}$  to reach stable operation. A stable supply current indicates stable operation.
- [3] During normal mode; for definition of duty cycle see [Figure 6](#).

## 9. Electromagnetic compatibility

---

The following tests by an independent and certified test laboratory have verified EMC:

### 9.1 Emission

- CISPR 25 (2008, third edition), Chapter 6.2: conducted emission, voltage method
- CISPR 25 (2002, second edition), Chapter 6.4: radiated emission, Absorber-Lined Shielded Enclosure (ALSE) method

### 9.2 Immunity to electrical transients

Tests were carried out with external protection circuit.

- ISO 7637-3: electrical transient transmission by capacitive coupling

### 9.3 Immunity to radiated disturbances

- ISO 11452-2: antenna in ALSE, including radar pulses
- ISO 11452-4: Bulk Current Injection (BCI)
  - Substitution method
- ISO 11452-5: strip line

## 10. ElectroStatic Discharge (ESD)

---

The following tests have verified ESD:

### 10.1 Human body model (AEC-Q100-002)

±8 kV at external pins ( $V_{CC}$  and GND)

±500 V at internal AMR bridge pins

### 10.2 Machine model (AEC-Q100-003)

±400 V at external pins ( $V_{CC}$  and GND)

±100 V at internal AMR bridge pins

### 10.3 Charged-device model (AEC-Q100-011)

±1 kV at external pins ( $V_{CC}$  and GND)

±500 V at internal AMR bridge pins

### 11. Application information

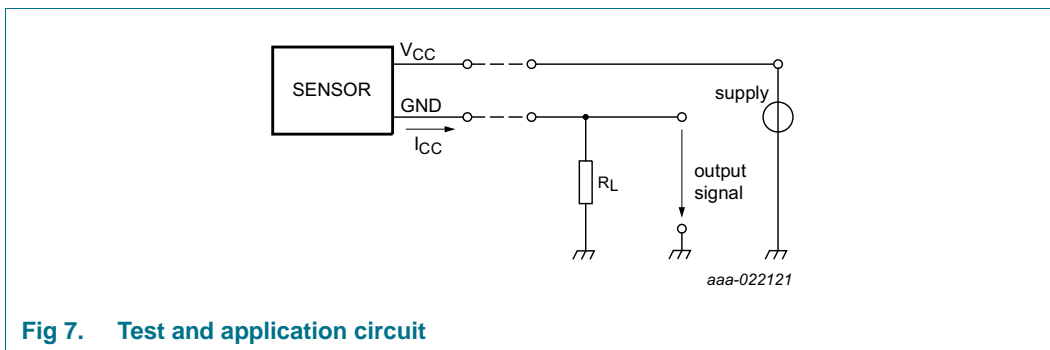

**Fig 7. Test and application circuit**

### 12. Test information

#### 12.1 Quality information

This product has been qualified in accordance with the Automotive Electronics Council (AEC) standard Q100 Rev-G (grade 0) - Failure mechanism based stress test qualification for integrated circuits, and is suitable for use in automotive applications.

### 13. Marking

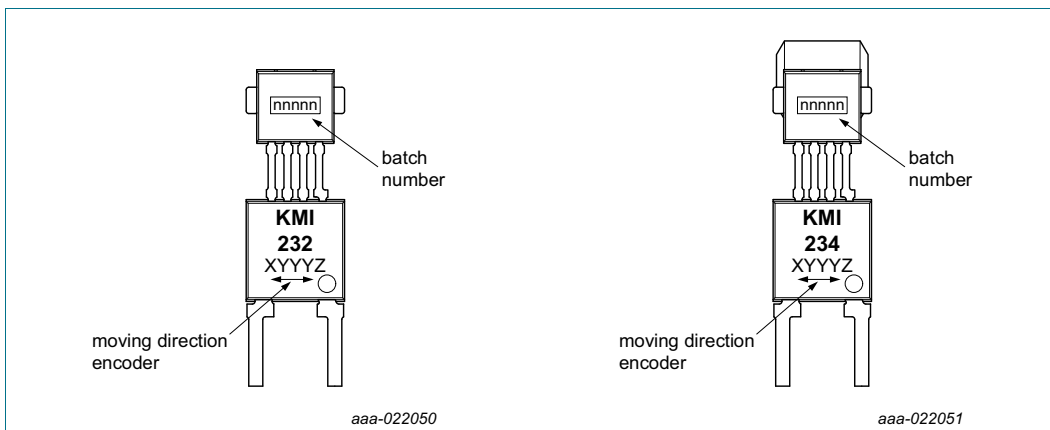

X: product manufacturing code; m for manufacturing Manila and p for manufacturing Hong Kong  
 YYY: day of year  
 Z: year of production (last figure)

a. KMI23/2

b. KMI23/4

**Fig 8. Marking**

14. Package outline

Plastic single-ended multi-chip package;  
magnetized ferrite magnet (3.8 x 2 x 0.8 mm); 4 interconnections; 2 in-line leads

SOT453A

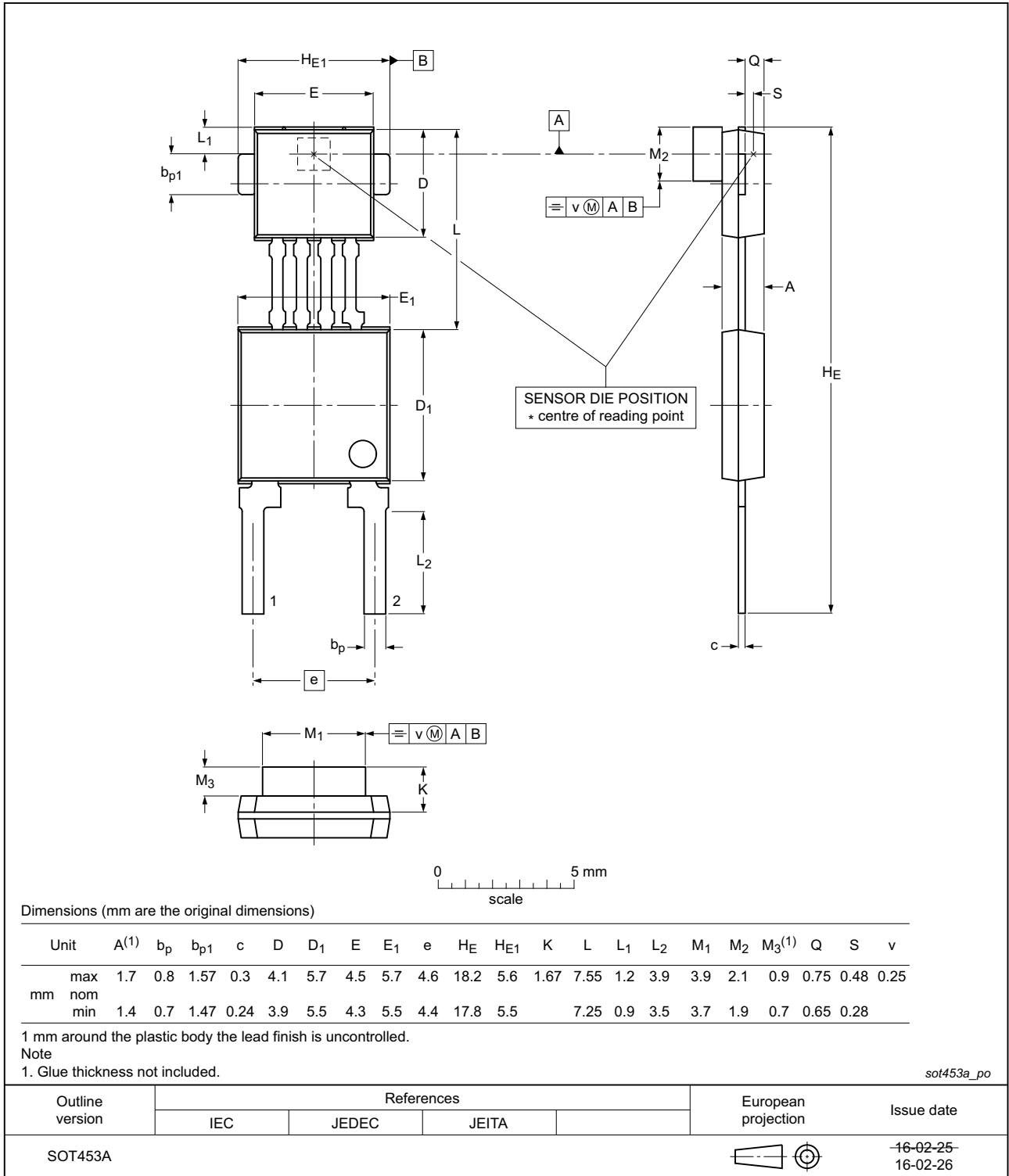

Fig 9. Package outline SOT453A (SIP2)

Plastic single-ended multi-chip package;  
magnetized ferrite magnet (4.25 x 5.2 x 3 mm); 4 interconnections; 2 in-line leads

SOT453E

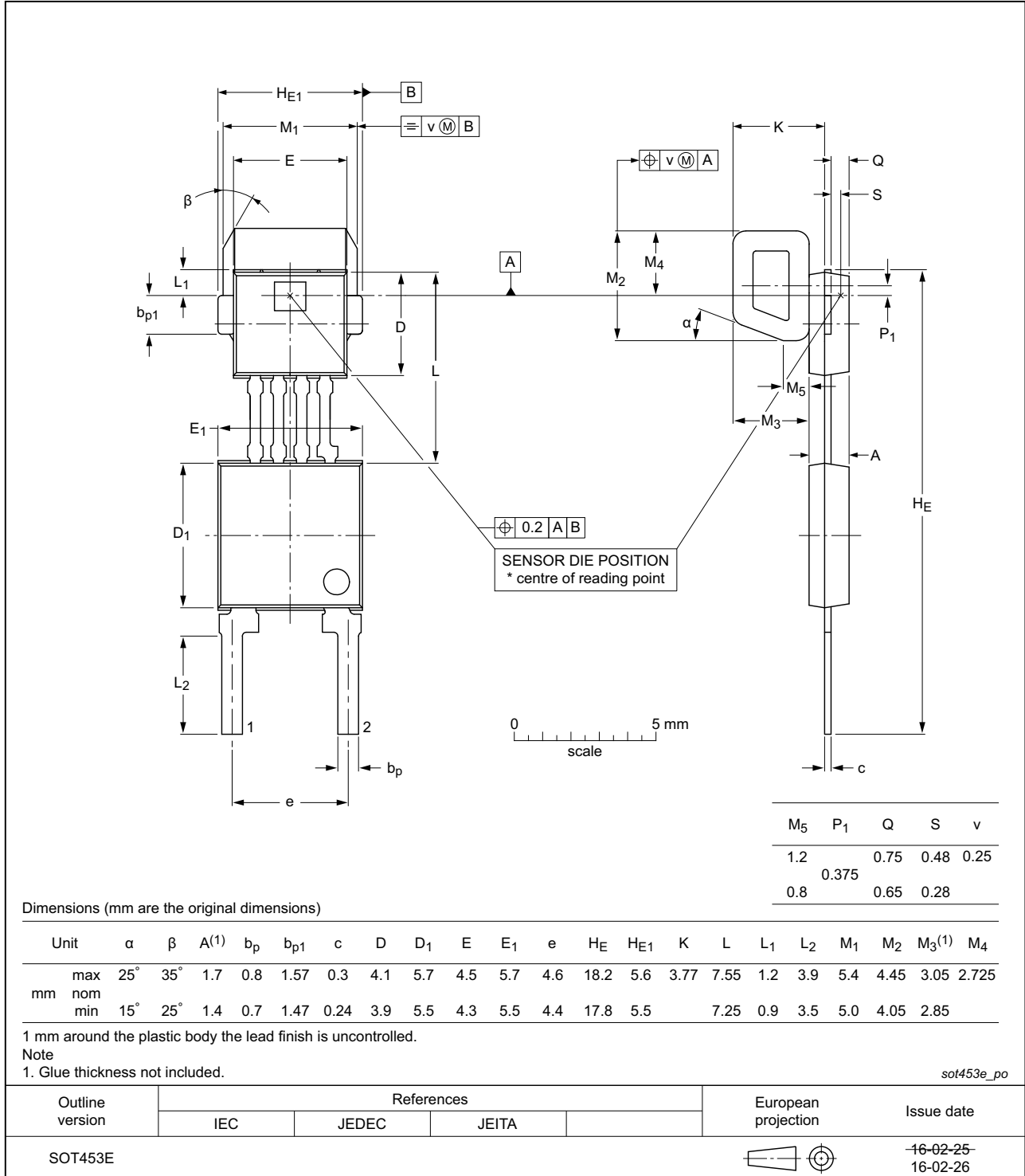
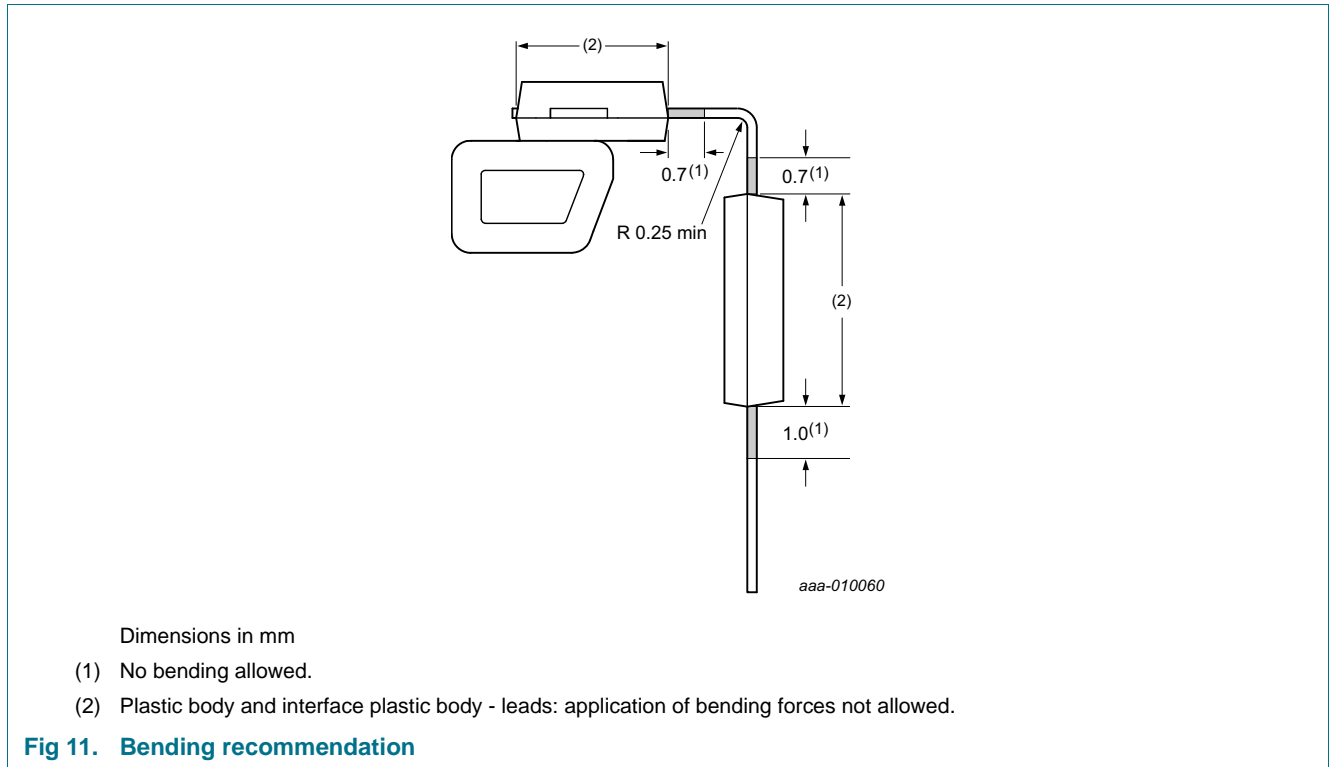

Fig 10. Package outline SOT453E (SIP2)



## 15. Handling information



## 16. Solderability information

The solderability qualification is according to AEC-Q100 Rev-G. Recommended soldering process for leaded devices is wave soldering. The maximum soldering temperature is 260 °C for maximum 5 s. Device terminals are compatible with laser and electrical welding. The device is reflow capable.

## 17. Revision history

**Table 7. Revision history**

Document ID	Release date	Data sheet status	Change notice	Supersedes
KMI23_2_4 v.1	20160428	Product data sheet	-	-

## 18. Legal information

### 18.1 Data sheet status

Document status <sup>[1][2]</sup>	Product status <sup>[3]</sup>	Definition
Objective [short] data sheet	Development	This document contains data from the objective specification for product development.
Preliminary [short] data sheet	Qualification	This document contains data from the preliminary specification.
Product [short] data sheet	Production	This document contains the product specification.

[1] Please consult the most recently issued document before initiating or completing a design.

[2] The term 'short data sheet' is explained in section "Definitions".

[3] The product status of device(s) described in this document may have changed since this document was published and may differ in case of multiple devices. The latest product status information is available on the Internet at URL <http://www.nxp.com>.

### 18.2 Definitions

**Draft** — The document is a draft version only. The content is still under internal review and subject to formal approval, which may result in modifications or additions. NXP Semiconductors does not give any representations or warranties as to the accuracy or completeness of information included herein and shall have no liability for the consequences of use of such information.

**Short data sheet** — A short data sheet is an extract from a full data sheet with the same product type number(s) and title. A short data sheet is intended for quick reference only and should not be relied upon to contain detailed and full information. For detailed and full information see the relevant full data sheet, which is available on request via the local NXP Semiconductors sales office. In case of any inconsistency or conflict with the short data sheet, the full data sheet shall prevail.

**Product specification** — The information and data provided in a Product data sheet shall define the specification of the product as agreed between NXP Semiconductors and its customer, unless NXP Semiconductors and customer have explicitly agreed otherwise in writing. In no event however, shall an agreement be valid in which the NXP Semiconductors product is deemed to offer functions and qualities beyond those described in the Product data sheet.

### 18.3 Disclaimers

**Limited warranty and liability** — Information in this document is believed to be accurate and reliable. However, NXP Semiconductors does not give any representations or warranties, expressed or implied, as to the accuracy or completeness of such information and shall have no liability for the consequences of use of such information. NXP Semiconductors takes no responsibility for the content in this document if provided by an information source outside of NXP Semiconductors.

In no event shall NXP Semiconductors be liable for any indirect, incidental, punitive, special or consequential damages (including - without limitation - lost profits, lost savings, business interruption, costs related to the removal or replacement of any products or rework charges) whether or not such damages are based on tort (including negligence), warranty, breach of contract or any other legal theory.

Notwithstanding any damages that customer might incur for any reason whatsoever, NXP Semiconductors' aggregate and cumulative liability towards customer for the products described herein shall be limited in accordance with the *Terms and conditions of commercial sale* of NXP Semiconductors.

**Right to make changes** — NXP Semiconductors reserves the right to make changes to information published in this document, including without limitation specifications and product descriptions, at any time and without notice. This document supersedes and replaces all information supplied prior to the publication hereof.

**Applications** — Applications that are described herein for any of these products are for illustrative purposes only. NXP Semiconductors makes no representation or warranty that such applications will be suitable for the specified use without further testing or modification.

Customers are responsible for the design and operation of their applications and products using NXP Semiconductors products, and NXP Semiconductors accepts no liability for any assistance with applications or customer product design. It is customer's sole responsibility to determine whether the NXP Semiconductors product is suitable and fit for the customer's applications and products planned, as well as for the planned application and use of customer's third party customer(s). Customers should provide appropriate design and operating safeguards to minimize the risks associated with their applications and products.

NXP Semiconductors does not accept any liability related to any default, damage, costs or problem which is based on any weakness or default in the customer's applications or products, or the application or use by customer's third party customer(s). Customer is responsible for doing all necessary testing for the customer's applications and products using NXP Semiconductors products in order to avoid a default of the applications and the products or of the application or use by customer's third party customer(s). NXP does not accept any liability in this respect.

**Limiting values** — Stress above one or more limiting values (as defined in the Absolute Maximum Ratings System of IEC 60134) will cause permanent damage to the device. Limiting values are stress ratings only and (proper) operation of the device at these or any other conditions above those given in the Recommended operating conditions section (if present) or the Characteristics sections of this document is not warranted. Constant or repeated exposure to limiting values will permanently and irreversibly affect the quality and reliability of the device.

**Terms and conditions of commercial sale** — NXP Semiconductors products are sold subject to the general terms and conditions of commercial sale, as published at <http://www.nxp.com/profile/terms>, unless otherwise agreed in a valid written individual agreement. In case an individual agreement is concluded only the terms and conditions of the respective agreement shall apply. NXP Semiconductors hereby expressly objects to applying the customer's general terms and conditions with regard to the purchase of NXP Semiconductors products by customer.

**No offer to sell or license** — Nothing in this document may be interpreted or construed as an offer to sell products that is open for acceptance or the grant, conveyance or implication of any license under any copyrights, patents or other industrial or intellectual property rights.

**Suitability for use in automotive applications** — This NXP Semiconductors product has been qualified for use in automotive applications. Unless otherwise agreed in writing, the product is not designed, authorized or warranted to be suitable for use in life support, life-critical or safety-critical systems or equipment, nor in applications where failure or malfunction of an NXP Semiconductors product can reasonably be expected to result in personal injury, death or severe property or environmental damage. NXP Semiconductors and its suppliers accept no liability for

inclusion and/or use of NXP Semiconductors products in such equipment or applications and therefore such inclusion and/or use is at the customer's own risk.

**Quick reference data** — The Quick reference data is an extract of the product data given in the Limiting values and Characteristics sections of this document, and as such is not complete, exhaustive or legally binding.

**Export control** — This document as well as the item(s) described herein may be subject to export control regulations. Export might require a prior authorization from competent authorities.

**Translations** — A non-English (translated) version of a document is for reference only. The English version shall prevail in case of any discrepancy between the translated and English versions.

## 18.4 Trademarks

Notice: All referenced brands, product names, service names and trademarks are the property of their respective owners.

## 19. Contact information

---

For more information, please visit: <http://www.nxp.com>

For sales office addresses, please send an email to: [salesaddresses@nxp.com](mailto:salesaddresses@nxp.com)

## 20. Contents

<b>1</b>	<b>Product profile</b> . . . . .	<b>1</b>
1.1	General description . . . . .	1
1.2	Features and benefits . . . . .	1
1.3	Quick reference data . . . . .	2
<b>2</b>	<b>Pinning information</b> . . . . .	<b>2</b>
<b>3</b>	<b>Ordering information</b> . . . . .	<b>2</b>
<b>4</b>	<b>Functional diagram</b> . . . . .	<b>3</b>
<b>5</b>	<b>Functional description</b> . . . . .	<b>3</b>
5.1	System architecture . . . . .	3
5.2	Speed signal conditioning algorithm . . . . .	5
5.2.1	Peak detector . . . . .	6
5.2.2	Frequency measurement . . . . .	7
5.2.3	Start-up mode . . . . .	7
5.2.4	Adaptation mode . . . . .	8
5.2.5	Normal mode . . . . .	8
5.2.6	Low-speed mode . . . . .	9
5.3	Output signal . . . . .	9
5.3.1	Physical representation of output signal . . . . .	9
<b>6</b>	<b>Limiting values</b> . . . . .	<b>10</b>
<b>7</b>	<b>Recommended operating conditions</b> . . . . .	<b>11</b>
<b>8</b>	<b>Characteristics</b> . . . . .	<b>11</b>
<b>9</b>	<b>Electromagnetic compatibility</b> . . . . .	<b>13</b>
9.1	Emission . . . . .	13
9.2	Immunity to electrical transients . . . . .	13
9.3	Immunity to radiated disturbances . . . . .	13
<b>10</b>	<b>ElectroStatic Discharge (ESD)</b> . . . . .	<b>13</b>
10.1	Human body model (AEC-Q100-002) . . . . .	13
10.2	Machine model (AEC-Q100-003) . . . . .	13
10.3	Charged-device model (AEC-Q100-011) . . . . .	13
<b>11</b>	<b>Application information</b> . . . . .	<b>14</b>
<b>12</b>	<b>Test information</b> . . . . .	<b>14</b>
12.1	Quality information . . . . .	14
<b>13</b>	<b>Marking</b> . . . . .	<b>14</b>
<b>14</b>	<b>Package outline</b> . . . . .	<b>15</b>
<b>15</b>	<b>Handling information</b> . . . . .	<b>17</b>
<b>16</b>	<b>Solderability information</b> . . . . .	<b>17</b>
<b>17</b>	<b>Revision history</b> . . . . .	<b>17</b>
<b>18</b>	<b>Legal information</b> . . . . .	<b>18</b>
18.1	Data sheet status . . . . .	18
18.2	Definitions . . . . .	18
18.3	Disclaimers . . . . .	18
18.4	Trademarks . . . . .	19
<b>19</b>	<b>Contact information</b> . . . . .	<b>19</b>
<b>20</b>	<b>Contents</b> . . . . .	<b>20</b>

Please be aware that important notices concerning this document and the product(s) described herein, have been included in section 'Legal information'.

© NXP Semiconductors N.V. 2016.

All rights reserved.

For more information, please visit: <http://www.nxp.com>

For sales office addresses, please send an email to: [salesaddresses@nxp.com](mailto:salesaddresses@nxp.com)

Date of release: 28 April 2016

Document identifier: KMI23\_2\_4