

# ISO674x General-Purpose Reinforced Quad-Channel Digital Isolators with Robust EMC

## 1 Features

- 50 Mbps data rate
- Robust isolation barrier:
  - High lifetime at 1060 V<sub>RMS</sub> working voltage
  - Up to 5000 V<sub>RMS</sub> isolation rating
  - Up to 10 kV surge capability
  - ±75 kV/μs typical CMTI
- Wide supply range: 1.71 V to 1.89 V and 2.25 V to 5.5 V
- 1.71 V to 5.5 V level translation
- Default output *high* (ISO674x) and *low* (ISO674xF) options
- Wide temperature range: –40°C to 125°C
- 1.6 mA per channel typical at 1 Mbps
- Low propagation delay: 11 ns typical
- Robust electromagnetic compatibility (EMC)
  - System-level ESD, EFT, and surge immunity
  - ±8 kV IEC 61000-4-2 contact discharge protection across isolation barrier
  - Low emissions
- Wide-SOIC (DW-16) Package
- [Safety-Related Certifications](#) (pending):
  - DIN V VDE 0884-11:2017-01
  - UL 1577 component recognition program
  - IEC 60950-1, IEC 62368-1, IEC 61010-1, IEC60601-1 and GB 4943.1-2011 certifications

## 2 Applications

- [Power supplies](#)
- [Grid, Electricity meter](#)
- [Motor drives](#)
- [Factory automation](#)
- [Building automation](#)
- [Lighting](#)
- [Appliances](#)

## 3 Description

The ISO674x devices are high-performance, quad-channel digital isolators ideal for cost-sensitive applications requiring up to 5000 V<sub>RMS</sub> isolation ratings per UL 1577. These devices are also certified by VDE, TUV, CSA, and CQC.

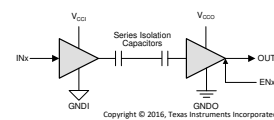
The ISO674x devices provide high electromagnetic immunity and low emissions at low power consumption, while isolating CMOS or LVCMOS digital I/Os. Each isolation channel has a logic input and output buffer separated by TI's double capacitive silicon dioxide (SiO<sub>2</sub>) insulation barrier. These devices come with enable pins which can be used to put the respective outputs in high impedance for multi-master driving applications. The ISO6740 device has all four channels in the same direction, ISO6741 device has three forward and one reverse-direction channels, and ISO6742 device has two forward and two reverse-direction channels. In the event of input power or signal loss, the default output is *high* for devices without suffix F and *low* for devices with suffix F. See [Device Functional Modes](#) section for further details.

Used in conjunction with isolated power supplies, these devices help prevent noise currents on data buses, such as UART, SPI, RS-485, RS-232, and CAN from damaging sensitive circuitry. Through innovative chip design and layout techniques, the electromagnetic compatibility of the ISO674x devices has been significantly enhanced to ease system-level ESD, EFT, surge, and emissions compliance. The ISO674x family of devices is available in a 16-pin SOIC wide-body (DW) package and is a pin-to-pin upgrade to the older generations.

### Device Information

PART NUMBER <sup>(1)</sup>	PACKAGE	BODY SIZE (NOM)
ISO6740, ISO6740F ISO6741, ISO6741F ISO6742, ISO6742F	SOIC (DW)	10.30 mm × 7.50 mm

- (1) For all available packages, see the orderable addendum at the end of the data sheet.



V<sub>CCI</sub>=Input supply, V<sub>CCO</sub>=Output supply  
GNDI=Input ground, GNDO=Output ground

### Simplified Schematic



## Table of Contents

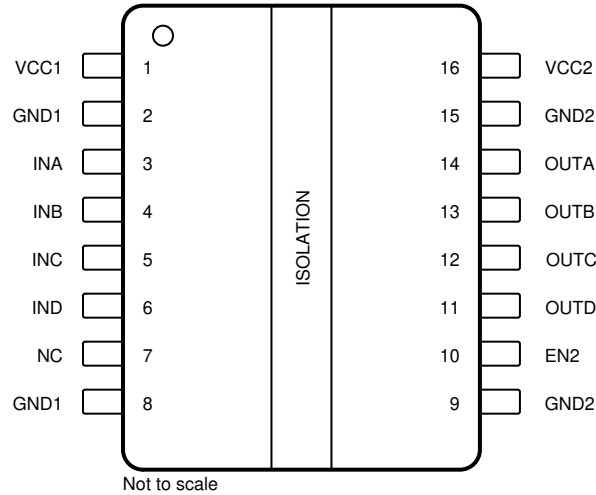
<b>1 Features</b> .....	1	6.21 Insulation Characteristics Curves.....	22
<b>2 Applications</b> .....	1	6.22 Typical Characteristics.....	23
<b>3 Description</b> .....	1	<b>7 Parameter Measurement Information</b> .....	24
<b>4 Revision History</b> .....	2	<b>8 Detailed Description</b> .....	26
<b>5 Pin Configuration and Functions</b> .....	3	8.1 Overview.....	26
<b>6 Specifications</b> .....	5	8.2 Functional Block Diagram.....	26
6.1 Absolute Maximum Ratings .....	5	8.3 Feature Description.....	27
6.2 ESD Ratings .....	5	8.4 Device Functional Modes.....	28
6.3 Recommended Operating Conditions .....	6	<b>9 Application and Implementation</b> .....	29
6.4 Thermal Information .....	7	9.1 Application Information.....	29
6.5 Power Ratings .....	7	9.2 Typical Application.....	29
6.6 Insulation Specifications .....	8	<b>10 Power Supply Recommendations</b> .....	33
6.7 Safety-Related Certifications .....	9	<b>11 Layout</b> .....	34
6.8 Safety Limiting Values .....	9	11.1 Layout Guidelines.....	34
6.9 Electrical Characteristics—5-V Supply .....	10	11.2 Layout Example.....	35
6.10 Supply Current Characteristics—5-V Supply .....	11	<b>12 Device and Documentation Support</b> .....	36
6.11 Electrical Characteristics—3.3-V Supply .....	12	12.1 Documentation Support.....	36
6.12 Supply Current Characteristics—3.3-V Supply .....	13	12.2 Receiving Notification of Documentation Updates.....	36
6.13 Electrical Characteristics—2.5-V Supply .....	14	12.3 Support Resources.....	36
6.14 Supply Current Characteristics—2.5-V Supply .....	15	12.4 Trademarks.....	36
6.15 Electrical Characteristics—1.8-V Supply .....	16	12.5 Electrostatic Discharge Caution.....	36
6.16 Supply Current Characteristics—1.8-V Supply .....	17	12.6 Glossary.....	36
6.17 Switching Characteristics—5-V Supply .....	18	<b>13 Mechanical, Packaging, and Orderable Information</b> .....	36
6.18 Switching Characteristics—3.3-V Supply .....	19	13.1 Package Option Addendum.....	37
6.19 Switching Characteristics—2.5-V Supply .....	20	13.2 Tape and Reel Information.....	38
6.20 Switching Characteristics—1.8-V Supply .....	21		

## 4 Revision History

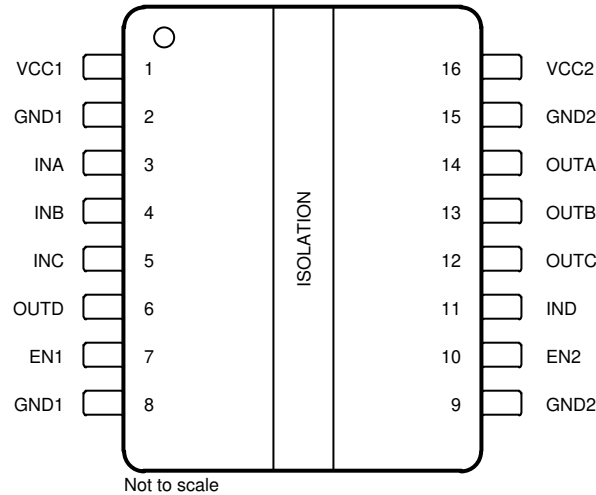
NOTE: Page numbers for previous revisions may differ from page numbers in the current version.

<b>Changes from Revision C (January 2021) to Revision D (March 2021)</b>	<b>Page</b>
• Added ISO6742 data under Specifications.....	5
<b>Changes from Revision B (December 2020) to Revision C (January 2021)</b>	<b>Page</b>
• Added ISO674x to data sheet.....	1
<b>Changes from Revision A (October 2020) to Revision B (December 2020)</b>	<b>Page</b>
• Updated device status to Production Data.....	1
<b>Changes from Revision * (August 2020) to Revision A (October 2020)</b>	<b>Page</b>
• Pre-RTM adjustments.....	1

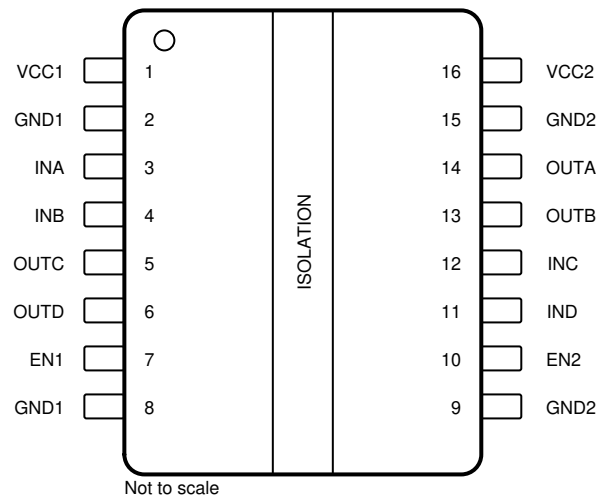
## 5 Pin Configuration and Functions



**Figure 5-1. ISO6740 DW Package 16-Pin SOIC-WB Top View**



**Figure 5-2. ISO6741 DW Package 16-Pin SOIC-WB Top View**



**Figure 5-3. ISO6742 DW Package 16-Pin SOIC-WB Top View**

**Pin Functions**

NAME	PIN			I/O	DESCRIPTION
	ISO6740	ISO6741	ISO6742		
EN1	-	7	7	I	Output enable 1. Output pins on side 1 are enabled when EN1 is high or open and in high-impedance state when EN1 is low. For ISO6740, this pin needs to be floating.
EN2	10	10	10	I	Output enable 2. Output pins on side 2 are enabled when EN2 is high or open and in high-impedance state when EN2 is low.
GND1	2, 8	2,8	2,8	—	Ground connection for $V_{CC1}$
GND2	9, 15	9,15	9,15	—	Ground connection for $V_{CC2}$
INA	3	3	3	I	Input, channel A
INB	4	4	4	I	Input, channel B
INC	5	5	12	I	Input, channel C
IND	6	11	11	I	Input, channel D
NC	7	-	-		Not connected
OUTA	14	14	14	O	Output, channel A
OUTB	13	13	13	O	Output, channel B
OUTC	12	12	5	O	Output, channel C
OUTD	11	6	6	O	Output, channel D
$V_{CC1}$	1	1	1	—	Power supply, side 1
$V_{CC2}$	16	16	16	—	Power supply, side 2

## 6 Specifications

### 6.1 Absolute Maximum Ratings

See<sup>(1)</sup>

		MIN	MAX	UNIT
Supply voltage <sup>(2)</sup>	$V_{CC1}, V_{CC2}$	-0.5	6	V
Voltage at INx, OUTx, ENx	V	-0.5	$V_{CCX} + 0.5$ <sup>(3)</sup>	V
Output current	$I_o$	-15	15	mA
Temperature	Operating junction temperature, $T_J$		150	°C
	Storage temperature, $T_{stg}$	-65	150	°C

- (1) Stresses beyond those listed under Absolute Maximum Ratings may cause permanent damage to the device. These are stress ratings only, which do not imply functional operation of the device at these or any other conditions beyond those indicated under Recommended Operating Conditions. Exposure to absolute-maximum-rated conditions for extended periods may affect device reliability.
- (2) All voltage values except differential I/O bus voltages are with respect to the local ground terminal (GND1 or GND2) and are peak voltage values
- (3) Maximum voltage must not exceed 6 V.

### 6.2 ESD Ratings

			VALUE	UNIT
$V_{(ESD)}$	Electrostatic discharge	Human body model (HBM), per ANSI/ESDA/JEDEC JS-001, all pins <sup>(1)</sup>	±6000	V
		Charged device model (CDM), per JEDEC specification JESD22-C101, all pins <sup>(2)</sup>	±1500	
		Contact discharge per IEC 61000-4-2; Isolation barrier withstand test <sup>(3) (4)</sup>	±8000	

- (1) JEDEC document JEP155 states that 500-V HBM allows safe manufacturing with a standard ESD control process.
- (2) JEDEC document JEP157 states that 250-V CDM allows safe manufacturing with a standard ESD control process.
- (3) IEC ESD strike is applied across the barrier with all pins on each side tied together creating a two-terminal device.
- (4) Testing is carried out in air or oil to determine the intrinsic contact discharge capability of the device.

### 6.3 Recommended Operating Conditions

over operating free-air temperature range (unless otherwise noted)

			MIN	NOM	MAX	UNIT
V <sub>CC1</sub> <sup>(1)</sup>	Supply Voltage Side 1	V <sub>CC</sub> = 1.8 V	1.71		1.89	V
V <sub>CC1</sub> <sup>(1)</sup>	Supply Voltage Side 1	V <sub>CC</sub> = 2.5 V to 5 V	2.25		5.5	V
V <sub>CC2</sub> <sup>(1)</sup>	Supply Voltage Side 2	V <sub>CC</sub> = 1.8 V	1.71		1.89	V
V <sub>CC2</sub> <sup>(1)</sup>	Supply Voltage Side 2	V <sub>CC</sub> = 2.5 V to 5 V	2.25		5.5	V
V <sub>CC</sub> (UVLO+)	UVLO threshold when supply voltage is rising			1.53	1.71	V
V <sub>CC</sub> (UVLO-)	UVLO threshold when supply voltage is falling		1.1	1.41		V
V <sub>hys</sub> (UVLO)	Supply voltage UVLO hysteresis		0.08	0.13		V
V <sub>IH</sub>	High level Input voltage		0.7 x V <sub>CCI</sub> <sup>(2)</sup>		V <sub>CCI</sub>	V
V <sub>IL</sub>	Low level Input voltage		0	0.3 x V <sub>CCI</sub>		V
I <sub>OH</sub>	High level output current	V <sub>CCO</sub> = 5 V <sup>(2)</sup>	-4			mA
		V <sub>CCO</sub> = 3.3 V	-2			mA
		V <sub>CCO</sub> = 2.5 V	-1			mA
		V <sub>CCO</sub> = 1.8 V	-1			mA
I <sub>OL</sub>	Low level output current	V <sub>CCO</sub> = 5 V			4	mA
		V <sub>CCO</sub> = 3.3 V			2	mA
		V <sub>CCO</sub> = 2.5 V			1	mA
		V <sub>CCO</sub> = 1.8 V			1	mA
DR	Data Rate		0		50	Mbps
T <sub>A</sub>	Ambient temperature		-40	25	125	°C

 (1) V<sub>CC1</sub> and V<sub>CC2</sub> can be set independent of one another

 (2) V<sub>CCI</sub> = Input-side V<sub>CC</sub>; V<sub>CCO</sub> = Output-side V<sub>CC</sub>

## 6.4 Thermal Information

THERMAL METRIC <sup>(1)</sup>		ISO674x	UNIT
		DW (SOIC)	
		16 PINS	
R <sub>θJA</sub>	Junction-to-ambient thermal resistance	73	°C/W
R <sub>θJC(top)</sub>	Junction-to-case (top) thermal resistance	36.1	°C/W
R <sub>θJB</sub>	Junction-to-board thermal resistance	40.4	°C/W
Ψ <sub>JT</sub>	Junction-to-top characterization parameter	17	°C/W
Ψ <sub>JB</sub>	Junction-to-board characterization parameter	39.9	°C/W
R <sub>θJC(bot)</sub>	Junction-to-case (bottom) thermal resistance	—	°C/W

(1) For more information about traditional and new thermal metrics, see the [Semiconductor and IC Package Thermal Metrics application report](#).

## 6.5 Power Ratings

PARAMETER		TEST CONDITIONS	MIN	TYP	MAX	UNIT
<b>ISO6740</b>						
P <sub>D</sub>	Maximum power dissipation (both sides)	V <sub>CC1</sub> = V <sub>CC2</sub> = 5.5 V, T <sub>J</sub> = 150°C, C <sub>L</sub> = 15 pF, Input a 25-MHz 50% duty cycle square wave			130.9	mW
P <sub>D1</sub>	Maximum power dissipation (side-1)				33	mW
P <sub>D2</sub>	Maximum power dissipation (side-2)				97.9	mW
<b>ISO6741</b>						
P <sub>D</sub>	Maximum power dissipation (both sides)	V <sub>CC1</sub> = V <sub>CC2</sub> = 5.5 V, T <sub>J</sub> = 150°C, C <sub>L</sub> = 15 pF, Input a 25-MHz 50% duty cycle square wave			134.9	mW
P <sub>D1</sub>	Maximum power dissipation (side-1)				50.8	mW
P <sub>D2</sub>	Maximum power dissipation (side-2)				84.1	mW

## 6.6 Insulation Specifications

PARAMETER		TEST CONDITIONS	VALUE	UNIT
			DW-16	
CLR	External clearance <sup>(1)</sup>	Shortest terminal-to-terminal distance through air	>8	mm
CPG	External creepage <sup>(1)</sup>	Shortest terminal-to-terminal distance across the package surface	>8	mm
DTI	Distance through the insulation	Minimum internal gap (internal clearance)	>17	um
CTI	Comparative tracking index	DIN EN 60112 (VDE 0303-11); IEC 60112	>600	V
	Material group	According to IEC 60664-1	I	
	Overvoltage category per IEC 60664-1	Rated mains voltage $\leq 600 V_{RMS}$	I-IV	
		Rated mains voltage $\leq 1000 V_{RMS}$	I-III	
<b>DIN VDE V 0884-11:2017-01</b> <sup>(2)</sup>				
$V_{IORM}$	Maximum repetitive peak isolation voltage	AC voltage (bipolar)	1500	$V_{PK}$
$V_{IOWM}$	Maximum working isolation voltage	AC voltage; Time dependent dielectric breakdown (TDDDB) Test; See <a href="#">Figure 9-8</a>	1060	$V_{RMS}$
		DC voltage	1500	$V_{DC}$
$V_{IOTM}$	Maximum transient isolation voltage	$V_{TEST} = V_{IOTM}$ , $t = 60$ s (qualification); $V_{TEST} = 1.2 \times V_{IOTM}$ , $t = 1$ s (100% production)	7071	$V_{PK}$
$V_{IOSM}$	Maximum surge isolation voltage <sup>(3)</sup>	Test method per IEC 62368-1, 1.2/50 $\mu$ s waveform, $V_{TEST} = 1.6 \times V_{IOSM}$ (qualification)	6250	$V_{PK}$
$q_{pd}$	Apparent charge <sup>(4)</sup>	Method a, After Input-output safety test subgroup 2/3, $V_{ini} = V_{IOTM}$ , $t_{ini} = 60$ s; $V_{pd(m)} = 1.2 \times V_{IORM}$ , $t_m = 10$ s	$\leq 5$	pC
		Method a, After environmental tests subgroup 1, $V_{ini} = V_{IOTM}$ , $t_{ini} = 60$ s; $V_{pd(m)} = 1.6 \times V_{IORM}$ , $t_m = 10$ s	$\leq 5$	
		Method b; At routine test (100% production) and preconditioning (type test) $V_{ini} = 1.2 \times V_{IOTM}$ , $t_{ini} = 1$ s; $V_{pd(m)} = 1.875 \times V_{IORM}$ , $t_m = 1$ s	$\leq 5$	
$C_{IO}$	Barrier capacitance, input to output <sup>(5)</sup>	$V_{IO} = 0.4 \times \sin(2\pi ft)$ , $f = 1$ MHz	$\sim 1$	pF
$R_{IO}$	Isolation resistance <sup>(5)</sup>	$V_{IO} = 500$ V, $T_A = 25^\circ$ C	$>10^{12}$	$\Omega$
		$V_{IO} = 500$ V, $100^\circ$ C $\leq T_A \leq 125^\circ$ C	$>10^{11}$	
		$V_{IO} = 500$ V at $T_S = 150^\circ$ C	$>10^9$	
	Pollution degree		2	
	Climatic category		40/125/21	
<b>UL 1577</b>				
$V_{ISO}$	Maximum withstanding isolation voltage	$V_{TEST} = V_{ISO}$ , $t = 60$ s (qualification), $V_{TEST} = 1.2 \times V_{ISO}$ , $t = 1$ s (100% production)	5000	$V_{RMS}$

- (1) Creepage and clearance requirements should be applied according to the specific equipment isolation standards of an application. Care should be taken to maintain the creepage and clearance distance of a board design to ensure that the mounting pads of the isolator on the printed-circuit board do not reduce this distance. Creepage and clearance on a printed-circuit board become equal in certain cases. Techniques such as inserting grooves and/or ribs on a printed-circuit board are used to help increase these specifications.
- (2) This coupler is suitable for *safe electrical insulation* only within the safety ratings. Compliance with the safety ratings shall be ensured by means of suitable protective circuits.
- (3) Testing is carried out in air or oil to determine the intrinsic surge immunity of the isolation barrier.
- (4) Apparent charge is electrical discharge caused by a partial discharge (pd).
- (5) All pins on each side of the barrier tied together creating a two-terminal device.



## 6.7 Safety-Related Certifications

VDE	CSA	UL	CQC	TUV
Plan to certify according to DIN VDE V 0884-11:2017-01	Plan to certify according to IEC 60950-1 and IEC 62368-1	Plan to certify according to UL 1577 Component Recognition Program	Plan to certify according to GB4943.1-2011	Plan to certify according to EN 61010-1:2010/A1:2019, EN 60950-1:2006/A2:2013 and EN 62368-1:2014
Maximum transient isolation voltage, $7071 V_{PK}$ ; Maximum repetitive peak isolation voltage, $1500 V_{PK}$ ; Maximum surge isolation voltage, $6250 V_{PK}$	5000 $V_{RMS}$ insulation per CSA 60950-1-07+A1+A2, IEC 60950-1 2nd Ed. +A1+A2, CSA 62368-1- 14 and IEC 62368-1:2014 800 $V_{RMS}$ (DW-16) maximum working voltage (pollution degree 2, material group I)	Single protection, 5000 $V_{RMS}$	Reinforced insulation, Altitude $\leq$ 5000 m, Tropical Climate, 700 $V_{RMS}$ maximum working voltage	5000 $V_{RMS}$ insulation per EN 61010-1:2010 (3rd Ed) up to working voltage of 600 $V_{RMS}$ 5000 $V_{RMS}$ insulation per EN 60950- 1:2006/A2:2013 up to working voltage of 800 $V_{RMS}$
Certificate planned	Certificate planned	File number: E181974	Certificate planned	Certificate planned

## 6.8 Safety Limiting Values

Safety limiting<sup>(1)</sup> intends to minimize potential damage to the isolation barrier upon failure of input or output circuitry.

PARAMETER		TEST CONDITIONS	MIN	TYP	MAX	UNIT
<b>DW-16 PACKAGE</b>						
$I_S$	Safety input, output, or supply current	$R_{\theta JA} = 73^\circ\text{C/W}$ , $V_I = 5.5\text{ V}$ , $T_J = 150^\circ\text{C}$ , $T_A = 25^\circ\text{C}$			311.4	mA
		$R_{\theta JA} = 73^\circ\text{C/W}$ , $V_I = 3.6\text{ V}$ , $T_J = 150^\circ\text{C}$ , $T_A = 25^\circ\text{C}$			475.7	
		$R_{\theta JA} = 73^\circ\text{C/W}$ , $V_I = 2.75\text{ V}$ , $T_J = 150^\circ\text{C}$ , $T_A = 25^\circ\text{C}$			622	mA
		$R_{\theta JA} = 73^\circ\text{C/W}$ , $V_I = 1.89\text{ V}$ , $T_J = 150^\circ\text{C}$ , $T_A = 25^\circ\text{C}$			905.1	
$P_S$	Safety input, output, or total power	$R_{\theta JA} = 73^\circ\text{C/W}$ , $T_J = 150^\circ\text{C}$ , $T_A = 25^\circ\text{C}$			1712.4	mW
$T_S$	Maximum safety temperature				150	$^\circ\text{C}$

- (1) The maximum safety temperature,  $T_S$ , has the same value as the maximum junction temperature,  $T_J$ , specified for the device. The  $I_S$  and  $P_S$  parameters represent the safety current and safety power respectively. The maximum limits of  $I_S$  and  $P_S$  should not be exceeded. These limits vary with the ambient temperature,  $T_A$ . The junction-to-air thermal resistance,  $R_{\theta JA}$ , in the table is that of a device installed on a high-K test board for leaded surface-mount packages. Use these equations to calculate the value for each parameter:  
 $T_J = T_A + R_{\theta JA} \times P$ , where  $P$  is the power dissipated in the device.  
 $T_{J(max)} = T_S = T_A + R_{\theta JA} \times P_S$ , where  $T_{J(max)}$  is the maximum allowed junction temperature.  
 $P_S = I_S \times V_I$ , where  $V_I$  is the maximum input voltage.

## 6.9 Electrical Characteristics—5-V Supply

$V_{CC1} = V_{CC2} = 5\text{ V} \pm 10\%$  (over recommended operating conditions unless otherwise noted)

PARAMETER		TEST CONDITIONS	MIN	TYP	MAX	UNIT
$V_{OH}$	High-level output voltage	$I_{OH} = -4\text{ mA}$ ; See <a href="#">Figure 7-1</a>	$V_{CCO} - 0.4$ <sup>(1)</sup>			V
$V_{OL}$	Low-level output voltage	$I_{OL} = 4\text{ mA}$ ; See <a href="#">Figure 7-1</a>			0.4	V
$V_{IT+(IN)}$	Rising input switching threshold			$0.7 \times V_{CCI}$ <sup>(1)</sup>		V
$V_{IT-(IN)}$	Falling input switching threshold		$0.3 \times V_{CCI}$			V
$V_{I(HYS)}$	Input threshold voltage hysteresis		$0.1 \times V_{CCI}$			V
$I_{IH}$	High-level input current	$V_{IH} = V_{CCI}$ <sup>(1)</sup> at INx			10	$\mu\text{A}$
$I_{IL}$	Low-level input current	$V_{IL} = 0\text{ V}$ at INx	-10			$\mu\text{A}$
$I_{IH}$	High-level input current	$V_{IH} = V_{CCI}$ <sup>(1)</sup> at ENx			28	$\mu\text{A}$
$I_{IL}$	Low-level input current	$V_{IL} = 0\text{ V}$ at ENx	-28			$\mu\text{A}$
CMTI	Common mode transient immunity	$V_I = V_{CC}$ or $0\text{ V}$ , $V_{CM} = 1200\text{ V}$ ; See <a href="#">Figure 7-4</a>	50	75		kV/us
$C_i$	Input Capacitance <sup>(2)</sup>	$V_I = V_{CC}/2 + 0.4 \times \sin(2\pi ft)$ , $f = 2\text{ MHz}$ , $V_{CC} = 5\text{ V}$		2.8		pF

(1)  $V_{CCI}$  = Input-side  $V_{CC}$ ;  $V_{CCO}$  = Output-side  $V_{CC}$

(2) Measured from input pin to same side ground.

## 6.10 Supply Current Characteristics—5-V Supply

$V_{CC1} = V_{CC2} = 5\text{ V} \pm 10\%$  (over recommended operating conditions unless otherwise noted)

PARAMETER	TEST CONDITIONS	SUPPLY CURRENT	MIN	TYP	MAX	UNIT	
<b>ISO6740</b>							
Supply current - DC signal (2)	$V_I = V_{CC1}$ (1)(ISO6740); $V_I = 0\text{ V}$ (ISO6740 with F suffix)	$I_{CC1}$		1.6	2.2	mA	
		$I_{CC2}$		2.1	3.4		
	$V_I = 0\text{ V}$ (ISO6740); $V_I = V_{CC1}$ (ISO6740 with F suffix)	$I_{CC1}$		5.8	8		
		$I_{CC2}$		2.3	3.7		
Supply current - AC signal (3)	All channels switching with square wave clock input; $C_L = 15\text{ pF}$	1 Mbps	$I_{CC1}$		3.7		5.1
			$I_{CC2}$		2.4		3.8
		10 Mbps	$I_{CC1}$		3.8		5.3
			$I_{CC2}$		4.8		6.4
		50 Mbps	$I_{CC1}$		4.4	6	
			$I_{CC2}$		15	17.8	
<b>ISO6741</b>							
Supply current - DC signal (2)	$V_I = V_{CCI}$ (1)(ISO6741); $V_I = 0\text{ V}$ (ISO6741 with F suffix)	$I_{CC1}$		1.9	2.8	mA	
		$I_{CC2}$		2.2	3.5		
	$V_I = 0\text{ V}$ (ISO6741); $V_I = V_{CCI}$ (ISO6741 with F suffix)	$I_{CC1}$		5.1	7.2		
		$I_{CC2}$		3.4	5.1		
Supply current - AC signal (3)	All channels switching with square wave clock input; $C_L = 15\text{ pF}$	1 Mbps	$I_{CC1}$		3.6		5.1
			$I_{CC2}$		3		4.5
		10 Mbps	$I_{CC1}$		4.2		5.8
			$I_{CC2}$		4.8		6.5
		50 Mbps	$I_{CC1}$		7.3	9.3	
			$I_{CC2}$		12.6	15.3	
<b>ISO6742</b>							
Supply current - DC signal (2)	$V_I = V_{CCI}$ (1)(ISO6742); $V_I = 0\text{ V}$ (ISO6742 with F suffix)	$I_{CC1}, I_{CC2}$		2.2	3.3	mA	
	$V_I = 0\text{ V}$ (ISO6742); $V_I = V_{CCI}$ (ISO6742 with F suffix)	$I_{CC1}, I_{CC2}$		4.4	6.3		
Supply current - AC signal (3)	All channels switching with square wave clock input; $C_L = 15\text{ pF}$	1 Mbps	$I_{CC1}, I_{CC2}$		3.4		5
		10 Mbps	$I_{CC1}, I_{CC2}$		4.7		6.4
		50 Mbps	$I_{CC1}, I_{CC2}$		10.2		12.5

(1)  $V_{CCI} = \text{Input-side } V_{CC}$

(2) Supply current valid for  $ENx = V_{CCx}$  and  $ENx = 0\text{V}$

(3) Supply current valid for  $ENx = V_{CCx}$

## 6.11 Electrical Characteristics—3.3-V Supply

$V_{CC1} = V_{CC2} = 3.3\text{ V} \pm 10\%$  (over recommended operating conditions unless otherwise noted)

PARAMETER		TEST CONDITIONS	MIN	TYP	MAX	UNIT
$V_{OH}$	High-level output voltage	$I_{OH} = -2\text{mA}$ ; See <a href="#">Figure 7-1</a>	$V_{CCO} - 0.2$ <sup>(1)</sup>			V
$V_{OL}$	Low-level output voltage	$I_{OL} = 2\text{mA}$ ; See <a href="#">Figure 7-1</a>			0.2	V
$V_{IT+(IN)}$	Rising input switching threshold			$0.7 \times V_{CCI}$ <sup>(1)</sup>		V
$V_{IT-(IN)}$	Falling input switching threshold		$0.3 \times V_{CCI}$			V
$V_{I(HYS)}$	Input threshold voltage hysteresis		$0.1 \times V_{CCI}$			V
$I_{IH}$	High-level input current	$V_{IH} = V_{CCI}$ <sup>(1)</sup> at INx			10	$\mu\text{A}$
$I_{IL}$	Low-level input current	$V_{IL} = 0\text{ V}$ at INx	-10			$\mu\text{A}$
$I_{IH}$	High-level input current	$V_{IH} = V_{CCI}$ <sup>(1)</sup> at ENx			30	$\mu\text{A}$
$I_{IL}$	Low-level input current	$V_{IL} = 0\text{ V}$ at ENx	-30			$\mu\text{A}$
CMTI	Common mode transient immunity	$V_I = V_{CC}$ or $0\text{ V}$ , $V_{CM} = 1200\text{ V}$ ; See <a href="#">Figure 7-4</a>	50	75		kV/us
$C_i$	Input Capacitance <sup>(2)</sup>	$V_I = V_{CC}/2 + 0.4 \times \sin(2\pi ft)$ , $f = 2\text{ MHz}$ , $V_{CC} = 3.3\text{ V}$		2.8		pF

(1)  $V_{CCI}$  = Input-side  $V_{CC}$ ;  $V_{CCO}$  = Output-side  $V_{CC}$

(2) Measured from input pin to same side ground.

## 6.12 Supply Current Characteristics—3.3-V Supply

$V_{CC1} = V_{CC2} = 3.3\text{ V} \pm 10\%$  (over recommended operating conditions unless otherwise noted)

PARAMETER	TEST CONDITIONS		SUPPLY CURRENT	MIN	TYP	MAX	UNIT
<b>ISO6740</b>							
Supply current - DC signal	EN2 = $V_{CC2}$ ; $V_I = V_{CC1}$ (ISO6740); $V_I = 0\text{ V}$ (ISO6740 with F suffix)		$I_{CC1}$		1.6	2.2	mA
			$I_{CC2}$		2.1	3.3	
	EN2 = $V_{CC2}$ ; $V_I = 0\text{ V}$ (ISO6740); $V_I = V_{CC1}$ (ISO6740 with F suffix)		$I_{CC1}$		5.7	8	
			$I_{CC2}$		2.3	3.6	
Supply current - AC signal	All channels switching with square wave clock input; $C_L = 15\text{ pF}$	1 Mbps	$I_{CC1}$		3.7	5.1	
			$I_{CC2}$		2.4	3.7	
		10 Mbps	$I_{CC1}$		3.8	5.2	
			$I_{CC2}$		4	5.6	
		50 Mbps	$I_{CC1}$		4.2	5.7	
			$I_{CC2}$		11.2	13.8	
<b>ISO6741</b>							
Supply current - DC signal (2)	$V_I = V_{CCI}$ (1)(ISO6741); $V_I = 0\text{ V}$ (ISO6741 with F suffix)		$I_{CC1}$		1.9	2.7	mA
			$I_{CC2}$		2.2	3.4	
	$V_I = 0\text{ V}$ (ISO6741); $V_I = V_{CCI}$ (ISO6741 with F suffix)		$I_{CC1}$		5	7.1	
			$I_{CC2}$		3.4	5.1	
Supply current - AC signal (3)	All channels switching with square wave clock input; $C_L = 15\text{ pF}$	1 Mbps	$I_{CC1}$		3.5	5	
			$I_{CC2}$		2.9	4.4	
		10 Mbps	$I_{CC1}$		4	5.5	
			$I_{CC2}$		4.2	5.8	
		50 Mbps	$I_{CC1}$		6.1	8	
			$I_{CC2}$		9.7	12.1	
<b>ISO6742</b>							
Supply current - DC signal	EN1 = EN2 = $V_{CCI}$ ; $V_I = V_{CCI}$ (ISO6742); $V_I = 0\text{ V}$ (ISO6742 with F suffix)		$I_{CC1}, I_{CC2}$		2.2	3.3	mA
	EN1 = EN2 = $0\text{ V}$ ; $V_I = 0\text{ V}$ (ISO6742); $V_I = V_{CCI}$ (ISO6742 with F suffix)		$I_{CC1}, I_{CC2}$		4.4	6.3	
Supply current - AC signal	All channels switching with square wave clock input; $C_L = 15\text{ pF}$	1 Mbps	$I_{CC1}, I_{CC2}$		3.4	4.9	
		10 Mbps	$I_{CC1}, I_{CC2}$		4.2	5.9	
		50 Mbps	$I_{CC1}, I_{CC2}$		8.2	10.3	

(1)  $V_{CCI} = \text{Input-side } V_{CC}$

(2) Supply current valid for  $ENx = V_{CCx}$  and  $ENx = 0\text{ V}$

(3) Supply current valid for  $ENx = V_{CCx}$

### 6.13 Electrical Characteristics—2.5-V Supply

 $V_{CC1} = V_{CC2} = 2.5\text{ V} \pm 10\%$  (over recommended operating conditions unless otherwise noted)

PARAMETER		TEST CONDITIONS	MIN	TYP	MAX	UNIT
$V_{OH}$	High-level output voltage	$I_{OH} = -1\text{mA}$ ; See <a href="#">Figure 7-1</a>	$V_{CCO} - 0.1$ <sup>(1)</sup>			V
$V_{OL}$	Low-level output voltage	$I_{OL} = 1\text{mA}$ ; See <a href="#">Figure 7-1</a>			0.1	V
$V_{IT+(IN)}$	Rising input switching threshold			$0.7 \times V_{CCI}$ <sup>(1)</sup>		V
$V_{IT-(IN)}$	Falling input switching threshold		$0.3 \times V_{CCI}$			V
$V_{I(HYS)}$	Input threshold voltage hysteresis		$0.1 \times V_{CCI}$			V
$I_{IH}$	High-level input current	$V_{IH} = V_{CCI}$ <sup>(1)</sup> at INx			10	$\mu\text{A}$
$I_{IL}$	Low-level input current	$V_{IL} = 0\text{ V}$ at INx	-10			$\mu\text{A}$
$I_{IH}$	High-level input current	$V_{IH} = V_{CCI}$ <sup>(1)</sup> at ENx			30	$\mu\text{A}$
$I_{IL}$	Low-level input current	$V_{IL} = 0\text{ V}$ at ENx	-30			$\mu\text{A}$
CMTI	Common mode transient immunity	$V_I = V_{CC}$ or $0\text{ V}$ , $V_{CM} = 1200\text{ V}$ ; See <a href="#">Figure 7-4</a>	50	75		kV/us
$C_i$	Input Capacitance <sup>(2)</sup>	$V_I = V_{CC}/2 + 0.4 \times \sin(2\pi ft)$ , $f = 2\text{ MHz}$ , $V_{CC} = 2.5\text{ V}$		2.8		pF

- (1)  $V_{CCI}$  = Input-side  $V_{CC}$ ;  $V_{CCO}$  = Output-side  $V_{CC}$   
 (2) Measured from input pin to same side ground.

## 6.14 Supply Current Characteristics—2.5-V Supply

$V_{CC1} = V_{CC2} = 2.5\text{ V} \pm 10\%$  (over recommended operating conditions unless otherwise noted)

PARAMETER	TEST CONDITIONS	SUPPLY CURRENT	MIN	TYP	MAX	UNIT	
<b>ISO6740</b>							
Supply current - DC signal	EN2 = $V_{CC2}$ ; $V_I = V_{CC1}$ (ISO6740); $V_I = 0\text{ V}$ (ISO6740 with F suffix)	$I_{CC1}$		1.6	2.2	mA	
		$I_{CC2}$		2.1	3.3		
	EN2 = $V_{CC2}$ ; $V_I = 0\text{ V}$ (ISO6740); $V_I = V_{CC1}$ (ISO6740 with F suffix)	$I_{CC1}$		5.7	7.9		
		$I_{CC2}$		2.3	3.6		
Supply current - AC signal	All channels switching with square wave clock input; $C_L = 15\text{ pF}$	1 Mbps	$I_{CC1}$		3.7		5.1
			$I_{CC2}$		2.3		3.6
		10 Mbps	$I_{CC1}$		3.7		5.1
			$I_{CC2}$		3.5		5.1
		50 Mbps	$I_{CC1}$		4.1	5.6	
			$I_{CC2}$		9	11.2	
<b>ISO6741</b>							
Supply current - DC signal (2)	$V_I = V_{CCI}$ (1)(ISO6741); $V_I = 0\text{ V}$ (ISO6741 with F suffix)	$I_{CC1}$		1.9	2.7	mA	
		$I_{CC2}$		2.2	3.4		
	$V_I = 0\text{ V}$ (ISO6741); $V_I = V_{CCI}$ (ISO6741 with F suffix)	$I_{CC1}$		5	7.1		
		$I_{CC2}$		3.4	5.1		
Supply current - AC signal (3)	All channels switching with square wave clock input; $C_L = 15\text{ pF}$	1 Mbps	$I_{CC1}$		3.5		5
			$I_{CC2}$		2.9		4.4
		10 Mbps	$I_{CC1}$		3.9		5.4
			$I_{CC2}$		3.8		5.4
		50 Mbps	$I_{CC1}$		5.5	7.2	
			$I_{CC2}$		8.1	10.2	
<b>ISO6742</b>							
Supply current - DC signal	EN1 = EN2 = $V_{CCI}$ ; $V_I = V_{CCI}$ (ISO6742); $V_I = 0\text{ V}$ (ISO6742 with F suffix)	$I_{CC1}, I_{CC2}$		2.2	3.3	mA	
	EN1 = EN2 = $0\text{ V}$ ; $V_I = 0\text{ V}$ (ISO6742); $V_I = V_{CCI}$ (ISO6742 with F suffix)	$I_{CC1}, I_{CC2}$		4.3	6.3		
Supply current - AC signal	All channels switching with square wave clock input; $C_L = 15\text{ pF}$	1 Mbps	$I_{CC1}, I_{CC2}$		3.3		4.8
		10 Mbps	$I_{CC1}, I_{CC2}$		4		5.6
		50 Mbps	$I_{CC1}, I_{CC2}$		7		9

(1)  $V_{CCI} = \text{Input-side } V_{CC}$

(2) Supply current valid for  $ENx = V_{CCx}$  and  $ENx = 0\text{ V}$

(3) Supply current valid for  $ENx = V_{CCx}$

## 6.15 Electrical Characteristics—1.8-V Supply

 $V_{CC1} = V_{CC2} = 1.8\text{ V} \pm 5\%$  (over recommended operating conditions unless otherwise noted)

PARAMETER		TEST CONDITIONS	MIN	TYP	MAX	UNIT
$V_{OH}$	High-level output voltage	$I_{OH} = -1\text{mA}$ ; See <a href="#">Figure 7-1</a>	$V_{CCO} - 0.1$ <sup>(1)</sup>			V
$V_{OL}$	Low-level output voltage	$I_{OL} = 1\text{mA}$ ; See <a href="#">Figure 7-1</a>			0.1	V
$V_{IT+(IN)}$	Rising input switching threshold			$0.7 \times V_{CCI}$ <sup>(1)</sup>		V
$V_{IT-(IN)}$	Falling input switching threshold		$0.3 \times V_{CCI}$			V
$V_{I(HYS)}$	Input threshold voltage hysteresis		$0.1 \times V_{CCI}$			V
$I_{IH}$	High-level input current	$V_{IH} = V_{CCI}$ <sup>(1)</sup> at INx			10	$\mu\text{A}$
$I_{IL}$	Low-level input current	$V_{IL} = 0\text{ V}$ at INx	-10			$\mu\text{A}$
$I_{IH}$	High-level input current	$V_{IH} = V_{CCI}$ <sup>(1)</sup> at ENx			30	$\mu\text{A}$
$I_{IL}$	Low-level input current	$V_{IL} = 0\text{ V}$ at ENx	-30			$\mu\text{A}$
CMTI	Common mode transient immunity	$V_I = V_{CC}$ or $0\text{ V}$ , $V_{CM} = 1200\text{ V}$ ; See <a href="#">Figure 7-4</a>	50	75		kV/us
$C_i$	Input Capacitance <sup>(2)</sup>	$V_I = V_{CC}/2 + 0.4 \times \sin(2\pi ft)$ , $f = 2\text{ MHz}$ , $V_{CC} = 1.8\text{ V}$		2.8		pF

(1)  $V_{CCI}$  = Input-side  $V_{CC}$ ;  $V_{CCO}$  = Output-side  $V_{CC}$

(2) Measured from input pin to same side ground.



## 6.16 Supply Current Characteristics—1.8-V Supply

$V_{CC1} = V_{CC2} = 1.8\text{ V} \pm 5\%$  (over recommended operating conditions unless otherwise noted)

PARAMETER	TEST CONDITIONS		SUPPLY CURRENT	MIN	TYP	MAX	UNIT
<b>ISO6740</b>							
Supply current - DC signal	EN2 = $V_{CC2}$ ; $V_I = V_{CC1}$ (ISO6740); $V_I = 0\text{ V}$ (ISO6740 with F suffix)		$I_{CC1}$		1.2	1.8	mA
			$I_{CC2}$		2	3.4	
	EN2 = $V_{CC2}$ ; $V_I = 0\text{ V}$ (ISO6740); $V_I = V_{CC1}$ (ISO6740 with F suffix)		$I_{CC1}$		5.1	7.6	
			$I_{CC2}$		2.2	3.7	
Supply current - AC signal	All channels switching with square wave clock input; $C_L = 15\text{ pF}$	1 Mbps	$I_{CC1}$		3.1	4.7	
			$I_{CC2}$		2.2	3.7	
		10 Mbps	$I_{CC1}$		3.2	4.8	
			$I_{CC2}$		3.1	4.6	
		50 Mbps	$I_{CC1}$		3.4	5.1	
			$I_{CC2}$		7	8.9	
<b>ISO6741</b>							
Supply current - DC signal (2)	$V_I = V_{CCI}$ (1)(ISO6741); $V_I = 0\text{ V}$ (ISO6741 with F suffix)		$I_{CC1}$		1.5	2.4	mA
			$I_{CC2}$		2	3.4	
	$V_I = 0\text{ V}$ (ISO6741); $V_I = V_{CCI}$ (ISO6741 with F suffix)		$I_{CC1}$		4.5	6.9	
			$I_{CC2}$		3.2	5	
Supply current - AC signal (3)	All channels switching with square wave clock input; $C_L = 15\text{ pF}$	1 Mbps	$I_{CC1}$		3.1	4.7	
			$I_{CC2}$		2.7	4.3	
		10 Mbps	$I_{CC1}$		3.3	5	
			$I_{CC2}$		3.4	5	
		50 Mbps	$I_{CC1}$		4.5	6.3	
			$I_{CC2}$		6.4	8.3	
<b>ISO6742</b>							
Supply current - DC signal	EN1 = EN2 = $V_{CCI}$ ; $V_I = V_{CCI}$ (ISO6742); $V_I = 0\text{ V}$ (ISO6742 with F suffix)		$I_{CC1}, I_{CC2}$		1.9	3.1	mA
	EN1 = EN2 = $0\text{ V}$ ; $V_I = 0\text{ V}$ (ISO6742); $V_I = V_{CCI}$ (ISO6742 with F suffix)		$I_{CC1}, I_{CC2}$		4	6.1	
Supply current - AC signal	All channels switching with square wave clock input; $C_L = 15\text{ pF}$	1 Mbps	$I_{CC1}, I_{CC2}$		3	4.7	
		10 Mbps	$I_{CC1}, I_{CC2}$		3.5	5.2	
		50 Mbps	$I_{CC1}, I_{CC2}$		5.6	7.6	

- (1)  $V_{CCI} = \text{Input-side } V_{CC}$   
(2) Supply current valid for  $ENx = V_{CCx}$  and  $ENx = 0\text{ V}$   
(3) Supply current valid for  $ENx = V_{CCx}$

## 6.17 Switching Characteristics—5-V Supply

$V_{CC1} = V_{CC2} = 5\text{ V} \pm 10\%$  (over recommended operating conditions unless otherwise noted)

PARAMETER		TEST CONDITIONS	MIN	TYP	MAX	UNIT
$t_{PLH}, t_{PHL}$	Propagation delay time	@100kbps See <a href="#">Figure 7-1</a>		11	18	ns
PWD	Pulse width distortion <sup>(1)</sup> $ t_{PHL} - t_{PLH} $			0.2	7	ns
$t_{sk(o)}$	Channel-to-channel output skew time <sup>(2)</sup>	Same-direction channels			6	ns
$t_{sk(pp)}$	Part-to-part skew time <sup>(3)</sup>				6	ns
$t_r$	Output signal rise time	See <a href="#">Figure 7-1</a>		2.6	4.5	ns
$t_f$	Output signal fall time			2.6	4.5	ns
$t_{PHZ}$	Disable propagation delay, high-to-high impedance output	See <a href="#">Figure 7-2</a>		18.6	25.8	ns
$t_{PLZ}$	Disable propagation delay, low-to-high impedance output			18.6	25.8	ns
$t_{PZH}$	Enable propagation delay, high impedance-to-high output for ISO674x			14.2	21.1	ns
$t_{PZL}$	Enable propagation delay, high impedance-to-low output for ISO674x			14.2	21.1	ns
$t_{PU}$	Time from UVLO to valid output data				300	us
$t_{DO}$	Default output delay time from input power loss	Measured from the time VCC goes below 1.2V. See <a href="#">Figure 7-3</a>		0.1	0.3	us
$t_{ie}$	Time interval error	$2^{16} - 1$ PRBS data at 50 Mbps		1		ns

(1) Also known as pulse skew.

(2)  $t_{sk(o)}$  is the skew between outputs of a single device with all driving inputs connected together and the outputs switching in the same direction while driving identical loads.

(3)  $t_{sk(pp)}$  is the magnitude of the difference in propagation delay times between any terminals of different devices switching in the same direction while operating at identical supply voltages, temperature, input signals and loads.

## 6.18 Switching Characteristics—3.3-V Supply

$V_{CC1} = V_{CC2} = 3.3\text{ V} \pm 10\%$  (over recommended operating conditions unless otherwise noted)

PARAMETER		TEST CONDITIONS	MIN	TYP	MAX	UNIT
$t_{PLH}, t_{PHL}$	Propagation delay time	@100kbps See <a href="#">Figure 7-1</a>		11	18	ns
PWD	Pulse width distortion <sup>(1)</sup> $ t_{PHL} - t_{PLH} $			0.5	7	ns
$t_{sk(o)}$	Channel-to-channel output skew time <sup>(2)</sup>	Same-direction channels			6	ns
$t_{sk(pp)}$	Part-to-part skew time <sup>(3)</sup>				7	ns
$t_r$	Output signal rise time	See <a href="#">Figure 7-1</a>		1.6	3.2	ns
$t_f$	Output signal fall time			1.6	3.2	ns
$t_{PHZ}$	Disable propagation delay, high-to-high impedance output	See <a href="#">Figure 7-2</a>		23.2	34.4	ns
$t_{PLZ}$	Disable propagation delay, low-to-high impedance output			23.2	34.4	ns
$t_{PZH}$	Enable propagation delay, high impedance-to-high output for ISO674x			16.6	23	ns
$t_{PZL}$	Enable propagation delay, high impedance-to-low output for ISO674x			16.6	23	ns
$t_{PU}$	Time from UVLO to valid output data				300	us
$t_{DO}$	Default output delay time from input power loss	Measured from the time VCC goes below 1.2V. See <a href="#">Figure 7-3</a>		0.1	0.3	us
$t_{ie}$	Time interval error	$2^{16} - 1$ PRBS data at 50 Mbps		1		ns

- (1) Also known as pulse skew.
- (2)  $t_{sk(o)}$  is the skew between outputs of a single device with all driving inputs connected together and the outputs switching in the same direction while driving identical loads.
- (3)  $t_{sk(pp)}$  is the magnitude of the difference in propagation delay times between any terminals of different devices switching in the same direction while operating at identical supply voltages, temperature, input signals and loads.

## 6.19 Switching Characteristics—2.5-V Supply

$V_{CC1} = V_{CC2} = 2.5\text{ V} \pm 10\%$  (over recommended operating conditions unless otherwise noted)

PARAMETER		TEST CONDITIONS	MIN	TYP	MAX	UNIT
$t_{PLH}, t_{PHL}$	Propagation delay time	@100kbps See <a href="#">Figure 7-1</a>		12	20.5	ns
PWD	Pulse width distortion <sup>(1)</sup> $ t_{PHL} - t_{PLH} $			0.6	7.1	ns
$t_{sk(o)}$	Channel-to-channel output skew time <sup>(2)</sup>	Same-direction channels			6	ns
$t_{sk(pp)}$	Part-to-part skew time <sup>(3)</sup>				7	ns
$t_r$	Output signal rise time	See <a href="#">Figure 7-1</a>		2	4	ns
$t_f$	Output signal fall time			2	4	ns
$t_{PHZ}$	Disable propagation delay, high-to-high impedance output	See <a href="#">Figure 7-2</a>		28.1	43	ns
$t_{PLZ}$	Disable propagation delay, low-to-high impedance output			28.1	43	ns
$t_{PZH}$	Enable propagation delay, high impedance-to-high output for ISO674x			20.4	36.3	ns
$t_{PZL}$	Enable propagation delay, high impedance-to-low output for ISO674x			20.4	36.3	ns
$t_{PU}$	Time from UVLO to valid output data				300	us
$t_{DO}$	Default output delay time from input power loss	Measured from the time VCC goes below 1.2V. See <a href="#">Figure 7-3</a>		0.1	0.3	us
$t_{ie}$	Time interval error	$2^{16} - 1$ PRBS data at 50 Mbps		1		ns

(1) Also known as pulse skew.

(2)  $t_{sk(o)}$  is the skew between outputs of a single device with all driving inputs connected together and the outputs switching in the same direction while driving identical loads.

(3)  $t_{sk(pp)}$  is the magnitude of the difference in propagation delay times between any terminals of different devices switching in the same direction while operating at identical supply voltages, temperature, input signals and loads.

## 6.20 Switching Characteristics—1.8-V Supply

$V_{CC1} = V_{CC2} = 1.8\text{ V} \pm 5\%$  (over recommended operating conditions unless otherwise noted)

PARAMETER		TEST CONDITIONS	MIN	TYP	MAX	UNIT
$t_{PLH}, t_{PHL}$	Propagation delay time	@100kbps See Figure 7-1		15	24	ns
PWD	Pulse width distortion <sup>(1)</sup> $ t_{PHL} - t_{PLH} $			0.7	8.2	ns
$t_{sk(o)}$	Channel-to-channel output skew time <sup>(2)</sup>	Same-direction channels			6	ns
$t_{sk(pp)}$	Part-to-part skew time <sup>(3)</sup>				8.8	ns
$t_r$	Output signal rise time	See Figure 7-1		2.7	5.3	ns
$t_f$	Output signal fall time			2.7	5.3	ns
$t_{PHZ}$	Disable propagation delay, high-to-high impedance output	See Figure 7-2		40.3	63	ns
$t_{PLZ}$	Disable propagation delay, low-to-high impedance output			40.3	63	ns
$t_{PZH}$	Enable propagation delay, high impedance-to-high output for ISO674x			30	51.4	ns
$t_{PZL}$	Enable propagation delay, high impedance-to-low output for ISO674x			30	51.4	ns
$t_{PU}$	Time from UVLO to valid output data				300	us
$t_{DO}$	Default output delay time from input power loss	Measured from the time VCC goes below 1.2V. See Figure 7-3		0.1	0.3	us
$t_{ie}$	Time interval error	$2^{16} - 1$ PRBS data at 50 Mbps		1		ns

- (1) Also known as pulse skew.
- (2)  $t_{sk(o)}$  is the skew between outputs of a single device with all driving inputs connected together and the outputs switching in the same direction while driving identical loads.
- (3)  $t_{sk(pp)}$  is the magnitude of the difference in propagation delay times between any terminals of different devices switching in the same direction while operating at identical supply voltages, temperature, input signals and loads.

## 6.21 Insulation Characteristics Curves

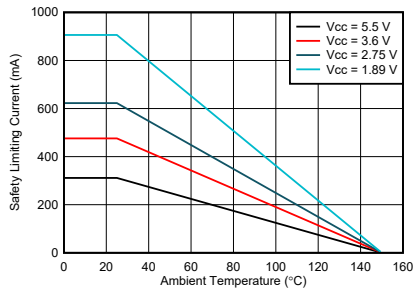


Figure 6-1. Thermal Derating Curve for Safety Limiting Current for DW-16 Package

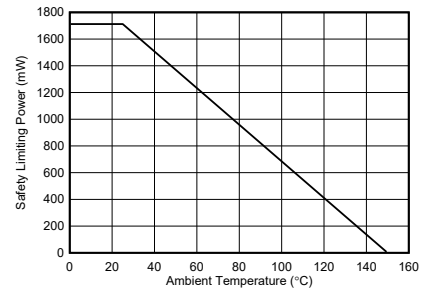
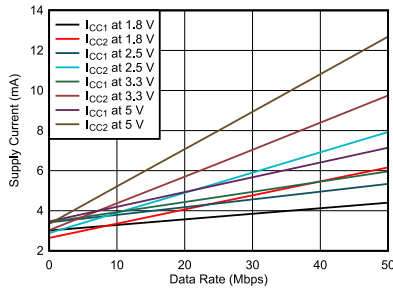


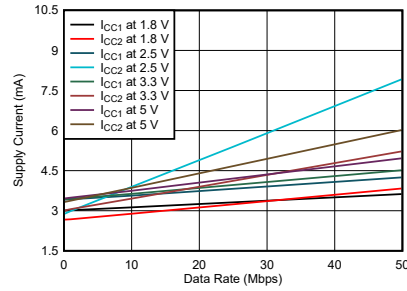
Figure 6-2. Thermal Derating Curve for Safety Limiting Power for DW-16 Package

## 6.22 Typical Characteristics



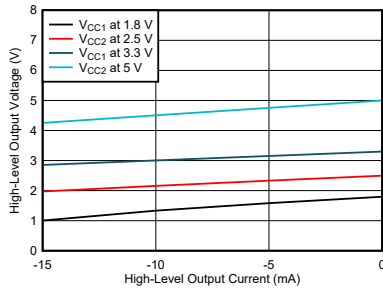
$T_A = 25^\circ\text{C}$   $C_L = 15\text{ pF}$

**Figure 6-3. ISO6741 Supply Current vs Data Rate (With 15-pF Load)**



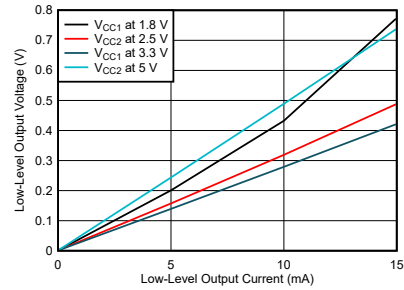
$T_A = 25^\circ\text{C}$   $C_L = \text{No Load}$

**Figure 6-4. ISO6741 Supply Current vs Data Rate (With No Load)**



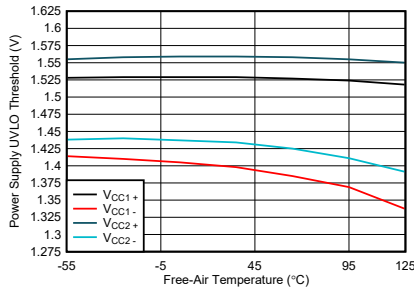
$T_A = 25^\circ\text{C}$

**Figure 6-5. High-Level Output Voltage vs High-level Output Current**

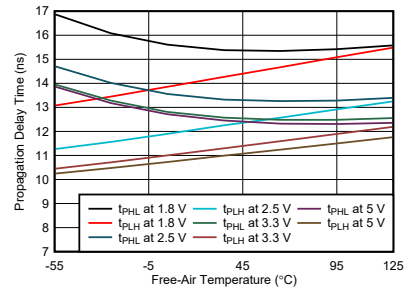


$T_A = 25^\circ\text{C}$

**Figure 6-6. Low-Level Output Voltage vs Low-Level Output Current**

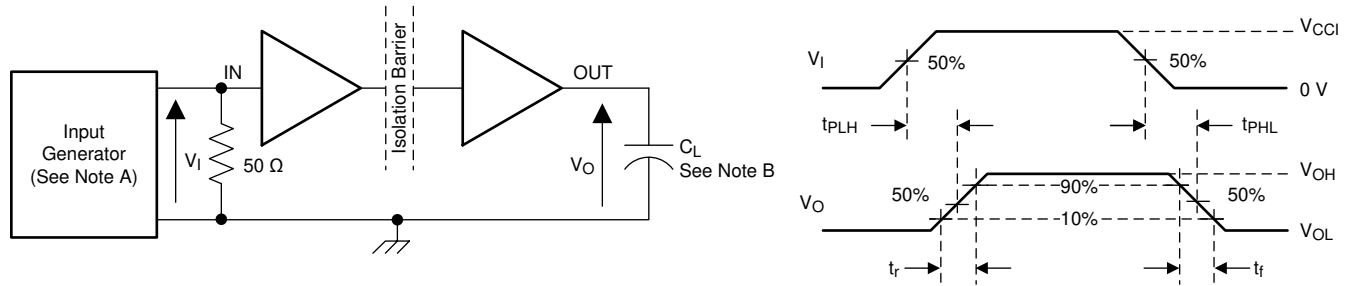


**Figure 6-7. Power Supply Undervoltage Threshold vs Free-Air Temperature**



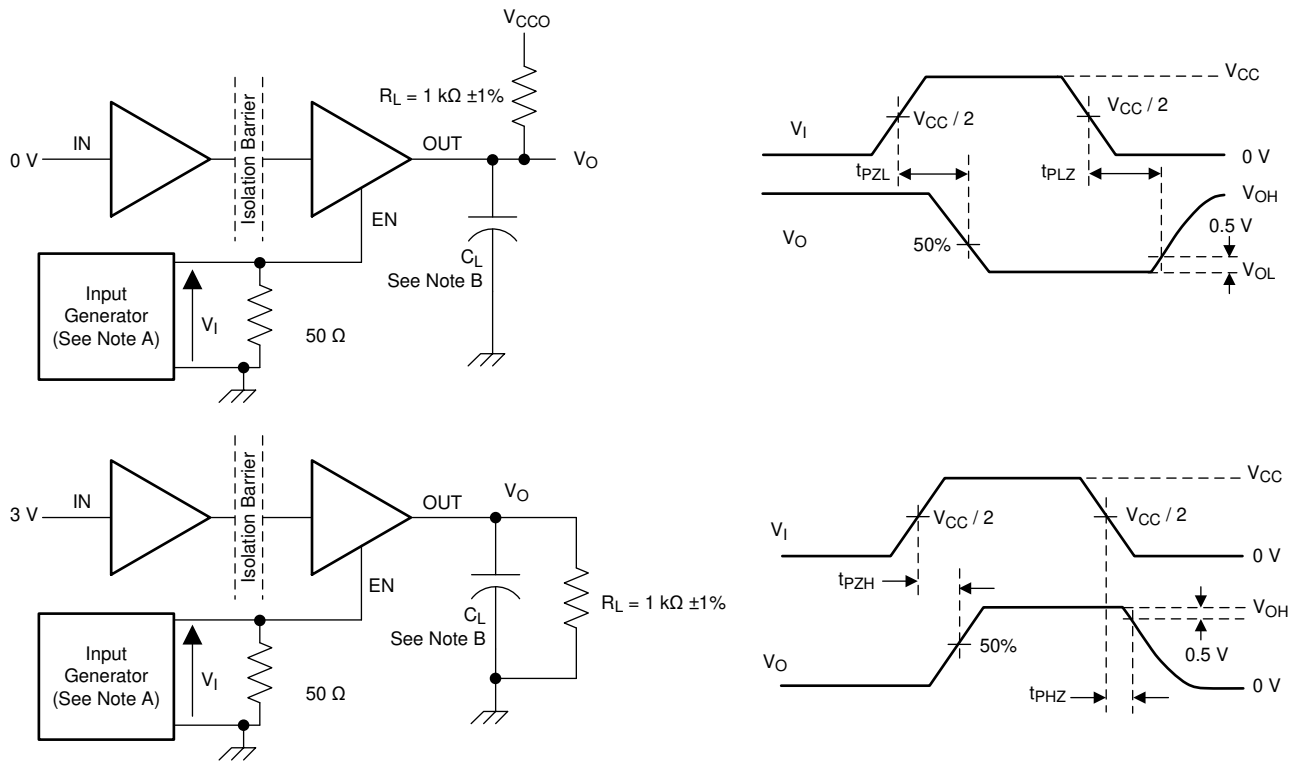
**Figure 6-8. Propagation Delay Time vs Free-Air Temperature**

## 7 Parameter Measurement Information



Copyright © 2016, Texas Instruments Incorporated

- A. The input pulse is supplied by a generator having the following characteristics: PRR  $\leq$  50 kHz, 50% duty cycle,  $t_r \leq 3$  ns,  $t_f \leq 3$  ns,  $Z_O = 50 \Omega$ . At the input, 50  $\Omega$  resistor is required to terminate Input Generator signal. It is not needed in actual application.
- B.  $C_L = 15$  pF and includes instrumentation and fixture capacitance within  $\pm 20\%$ .

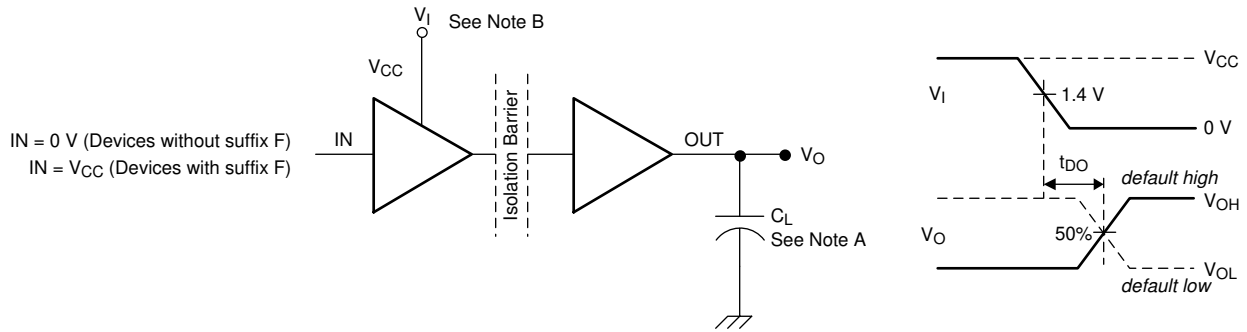
**Figure 7-1. Switching Characteristics Test Circuit and Voltage Waveforms**


Copyright © 2016, Texas Instruments Incorporated

- A. The input pulse is supplied by a generator having the following characteristics: PRR  $\leq$  10 kHz, 50% duty cycle,  $t_r \leq 3$  ns,  $t_f \leq 3$  ns,  $Z_O = 50 \Omega$ .
- B.  $C_L = 15$  pF and includes instrumentation and fixture capacitance within  $\pm 20\%$ .

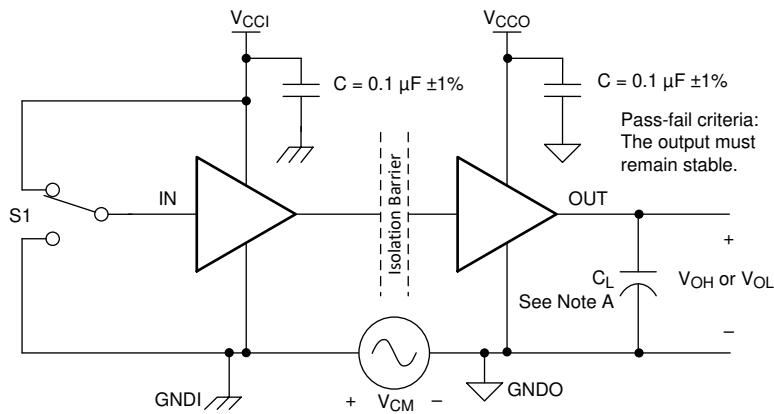
**Figure 7-2. Enable/Disable Propagation Delay Time Test Circuit and Waveform**





- A.  $C_L = 15\text{ pF}$  and includes instrumentation and fixture capacitance within  $\pm 20\%$ .
- B. Power Supply Ramp Rate =  $10\text{ mV/ns}$

**Figure 7-3. Default Output Delay Time Test Circuit and Voltage Waveforms**



- A.  $C_L = 15\text{ pF}$  and includes instrumentation and fixture capacitance within  $\pm 20\%$ .

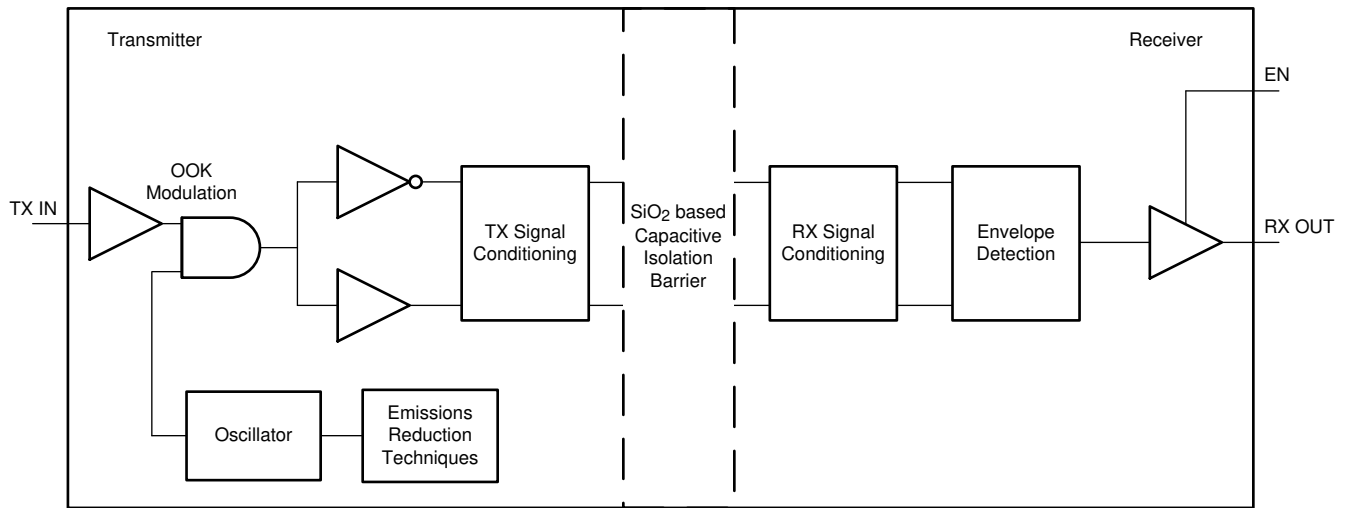
**Figure 7-4. Common-Mode Transient Immunity Test Circuit**

## 8 Detailed Description

### 8.1 Overview

The ISO674x family of devices have an ON-OFF keying (OOK) modulation scheme to transmit the digital data across a silicon dioxide based isolation barrier. The transmitter sends a high frequency carrier across the barrier to represent one digital state and sends no signal to represent the other digital state. The receiver demodulates the signal after advanced signal conditioning and produces the output through a buffer stage. If the ENx pin is low then the output goes to high impedance. The ISO674x devices also incorporate advanced circuit techniques to maximize the CMTI performance and minimize the radiated emissions due to the high frequency carrier and IO buffer switching. The conceptual block diagram of a digital capacitive isolator, [Figure 8-1](#), shows a functional block diagram of a typical channel.

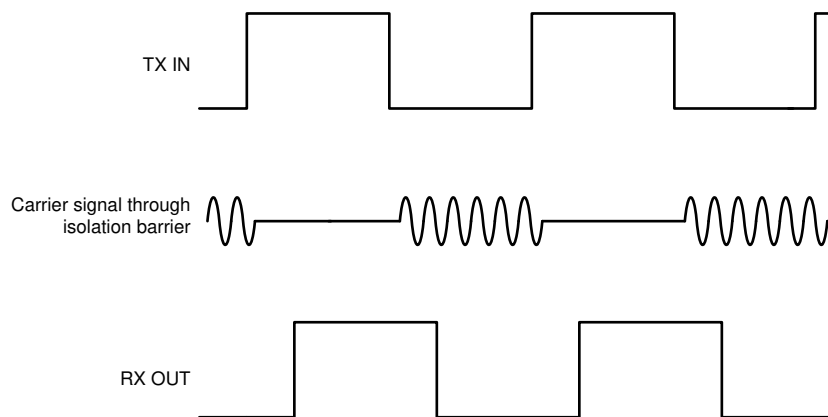
### 8.2 Functional Block Diagram



Copyright © 2016, Texas Instruments Incorporated

**Figure 8-1. Conceptual Block Diagram of a Digital Capacitive Isolator**

[Figure 8-2](#) shows a conceptual detail of how the ON-OFF keying scheme works.



**Figure 8-2. On-Off Keying (OOK) Based Modulation Scheme**

## 8.3 Feature Description

Table 8-1 provides an overview of the device features.

**Table 8-1. Device Features**

PART NUMBER	CHANNEL DIRECTION	MAXIMUM DATA RATE	DEFAULT OUTPUT	PACKAGE	RATED ISOLATION <sup>(1)</sup>
ISO6740	4 Forward, 0 Reverse	50 Mbps	High	DW-16	5000 V <sub>RMS</sub> / 8000 V <sub>PK</sub>
ISO6740F	4 Forward, 0 Reverse	50 Mbps	Low	DW-16	5000 V <sub>RMS</sub> / 8000 V <sub>PK</sub>
ISO6741	3 Forward, 1 Reverse	50 Mbps	High	DW-16	5000 V <sub>RMS</sub> / 8000 V <sub>PK</sub>
ISO6741F	3 Forward, 1 Reverse	50 Mbps	Low	DW-16	5000 V <sub>RMS</sub> / 8000 V <sub>PK</sub>
ISO6742	2 Forward, 2 Reverse	50 Mbps	High	DW-16	5000 V <sub>RMS</sub> / 8000 V <sub>PK</sub>
ISO6742F	2 Forward, 2 Reverse	50 Mbps	Low	DW-16	5000 V <sub>RMS</sub> / 8000 V <sub>PK</sub>

(1) See for detailed isolation ratings.

### 8.3.1 Electromagnetic Compatibility (EMC) Considerations

Many applications in harsh industrial environment are sensitive to disturbances such as electrostatic discharge (ESD), electrical fast transient (EFT), surge and electromagnetic emissions. These electromagnetic disturbances are regulated by international standards such as IEC 61000-4-x and CISPR 22. Although system-level performance and reliability depends, to a large extent, on the application board design and layout, the ISO674x family of devices incorporates many chip-level design improvements for overall system robustness. Some of these improvements include:

- Robust ESD protection cells for input and output signal pins and inter-chip bond pads.
- Low-resistance connectivity of ESD cells to supply and ground pins.
- Enhanced performance of high voltage isolation capacitor for better tolerance of ESD, EFT and surge events.
- Bigger on-chip decoupling capacitors to bypass undesirable high energy signals through a low impedance path.
- PMOS and NMOS devices isolated from each other by using guard rings to avoid triggering of parasitic SCRs.
- Reduced common mode currents across the isolation barrier by ensuring purely differential internal operation.

## 8.4 Device Functional Modes

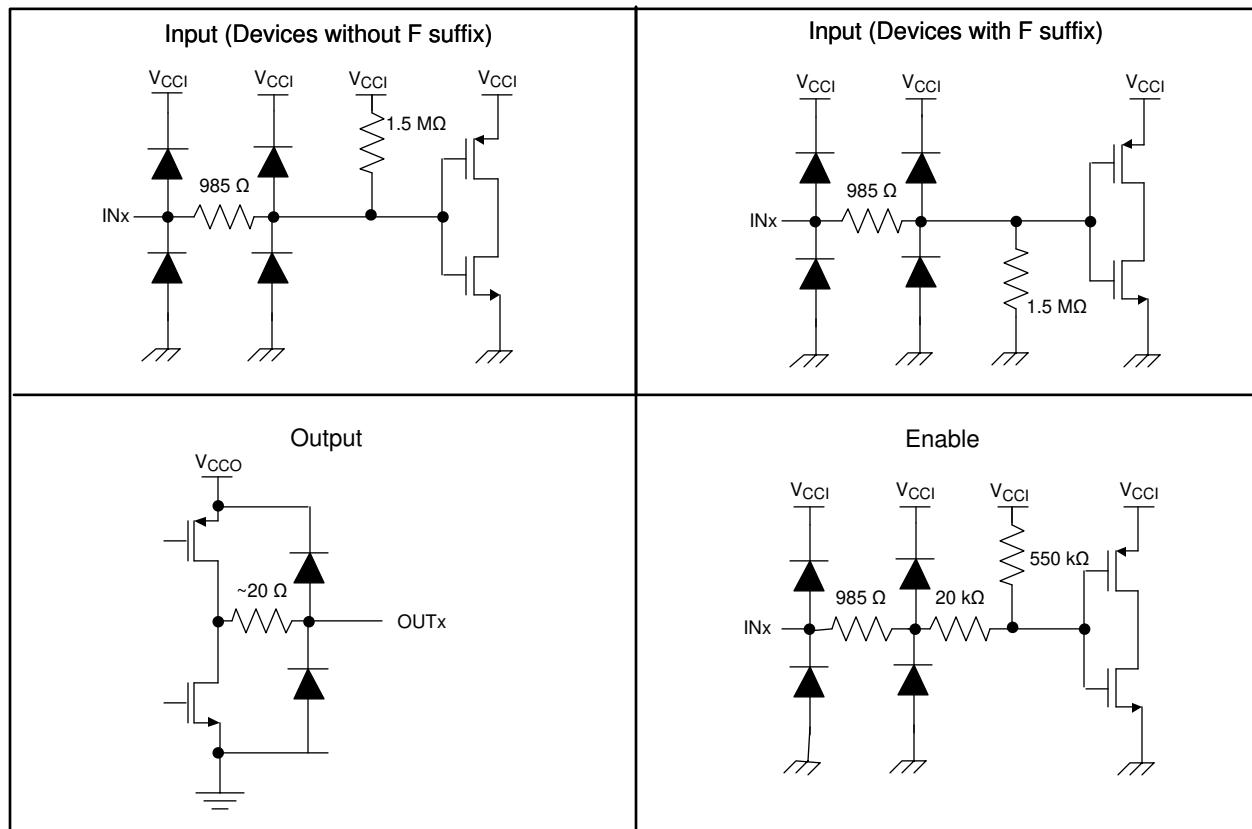
Table 8-2 lists the functional modes for the ISO674x devices.

**Table 8-2. Function Table**

V <sub>CCI</sub> <sup>(1)</sup>	V <sub>CCO</sub>	INPUT (IN <sub>x</sub> ) <sup>(3)</sup>	OUTPUT ENABLE (EN <sub>x</sub> )	OUTPUT (OUT <sub>x</sub> )	COMMENTS
PU	PU	H	H or open	H	Normal Operation: A channel output assumes the logic state of its input.
		L	H or open	L	
		Open	H or open	Default	Default mode: When IN <sub>x</sub> is open, the corresponding channel output goes to its default logic state. Default is <i>High</i> for ISO674x and <i>Low</i> for ISO674x with F suffix.
X	PU	X	L	Z	A low value of output enable causes the outputs to be high-impedance.
PD	PU	X	H or open	Default	Default mode: When V <sub>CCI</sub> is unpowered, a channel output assumes the logic state based on the selected default option. Default is <i>High</i> for ISO674x and <i>Low</i> for ISO674x with F suffix. When V <sub>CCI</sub> transitions from unpowered to powered-up, a channel output assumes the logic state of the input. When V <sub>CCI</sub> transitions from powered-up to unpowered, channel output assumes the selected default state.
X	PD	X	X	Undetermined	When V <sub>CCO</sub> is unpowered, a channel output is undetermined <sup>(2)</sup> . When V <sub>CCO</sub> transitions from unpowered to powered-up, a channel output assumes the logic state of the input.

- (1) V<sub>CCI</sub> = Input-side V<sub>CC</sub>; V<sub>CCO</sub> = Output-side V<sub>CC</sub>; PU = Powered up (V<sub>CC</sub> ≥ 1.71 V); PD = Powered down (V<sub>CC</sub> ≤ 1.05 V); X = Irrelevant; H = High level; L = Low level; Z = High Impedance
- (2) The outputs are in undetermined state when 1.7 V < V<sub>CCI</sub>, V<sub>CCO</sub> < 2.25 V and 1.05 V < V<sub>CCI</sub>, V<sub>CCO</sub> < 1.71 V
- (3) A strongly driven input signal can weakly power the floating V<sub>CC</sub> through an internal protection diode and cause undetermined output

### 8.4.1 Device I/O Schematics



**Figure 8-3. Device I/O Schematics**

## 9 Application and Implementation

### Note

Information in the following applications sections is not part of the TI component specification, and TI does not warrant its accuracy or completeness. TI's customers are responsible for determining suitability of components for their purposes. Customers should validate and test their design implementation to confirm system functionality.

### 9.1 Application Information

The ISO674x devices are high-performance, quad-channel digital isolators. These devices come with enable pins on each side which can be used to put the respective outputs in high impedance for multi master driving applications. The ISO674x devices use single-ended CMOS-logic switching technology. The supply voltage range is from 1.71 V to 5.5 V for both supplies,  $V_{CC1}$  and  $V_{CC2}$ . Since an isolation barrier separates the two sides, each side can be sourced independently with any voltage within recommended operating conditions. As an example, it is possible to supply ISO674x  $V_{CC1}$  with 3.3 V (which is within 1.71 V to 5.5 V) and  $V_{CC2}$  with 5V (which is also within 1.71 V to 5.5 V). You can use the digital isolator as a logic-level translator in addition to providing isolation. When designing with digital isolators, keep in mind that because of the single-ended design structure, digital isolators do not conform to any specific interface standard and are only intended for isolating single-ended CMOS or TTL digital signal lines. The isolator is typically placed between the data controller (that is,  $\mu$ C or UART), and a data converter or a line transceiver, regardless of the interface type or standard.

### 9.2 Typical Application

Figure 9-1 shows the isolated serial peripheral interface (SPI).

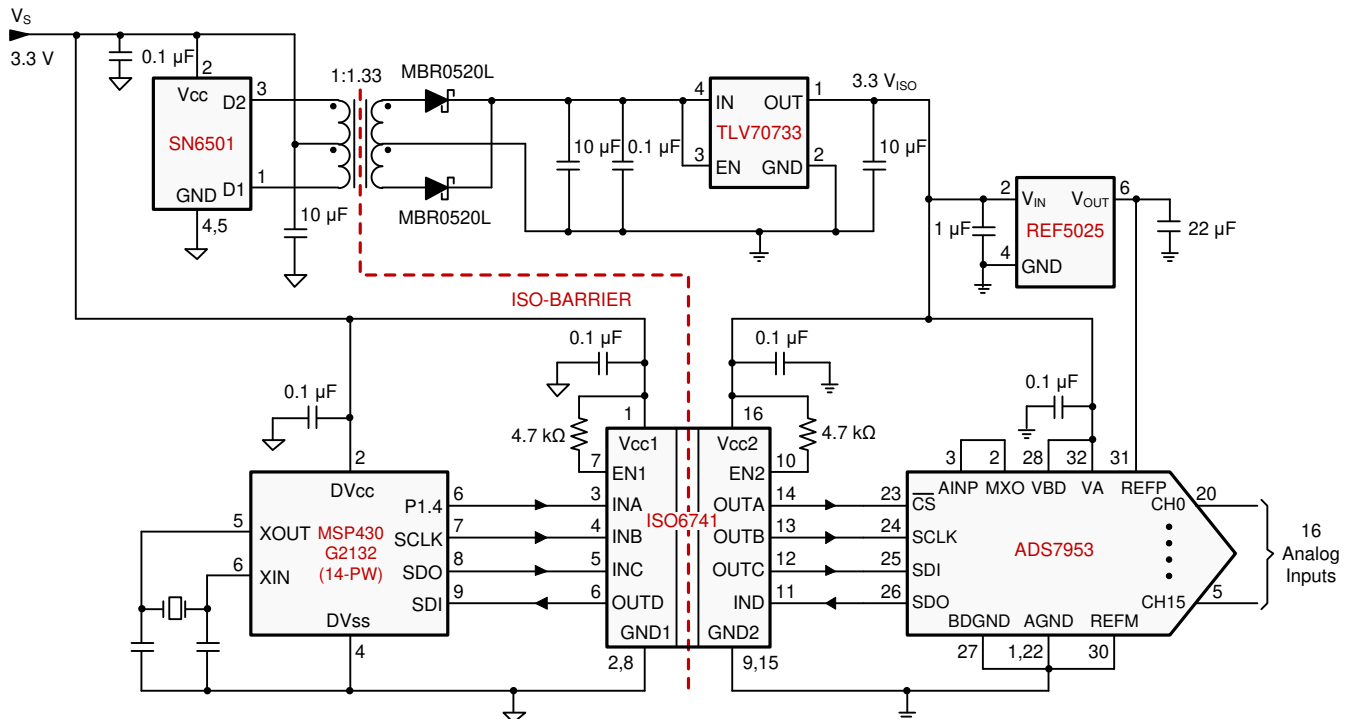


Figure 9-1. Isolated SPI for an Analog Input Module With 16 Inputs

### 9.2.1 Design Requirements

To design with these devices, use the parameters listed in [Table 9-1](#).

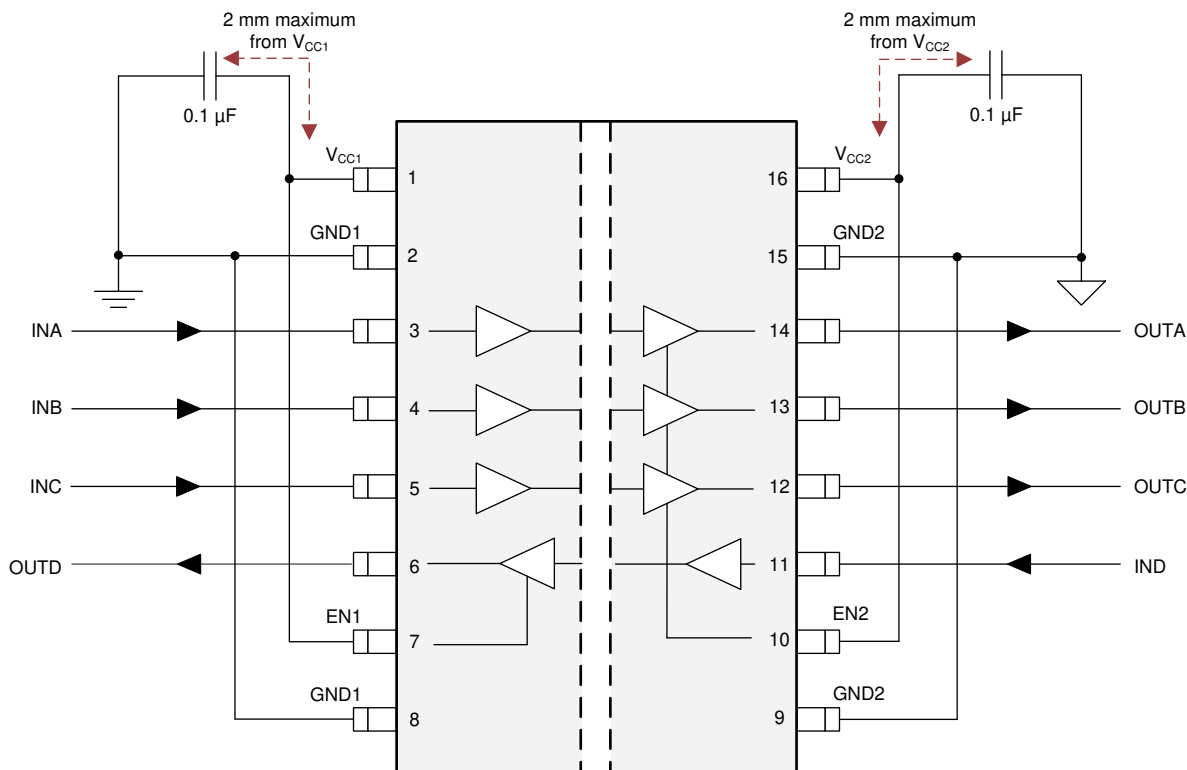
**Table 9-1. Design Parameters**

PARAMETER	VALUE
Supply voltage, $V_{CC1}$ and $V_{CC2}$	1.71 V to 1.89 V and 2.25 V to 5.5 V
Decoupling capacitor between $V_{CC1}$ and GND1	0.1 $\mu$ F
Decoupling capacitor from $V_{CC2}$ and GND2	0.1 $\mu$ F

### 9.2.2 Detailed Design Procedure

Unlike optocouplers, which require external components to improve performance, provide bias, or limit current, the ISO674x family of devices only require two external bypass capacitors to operate.

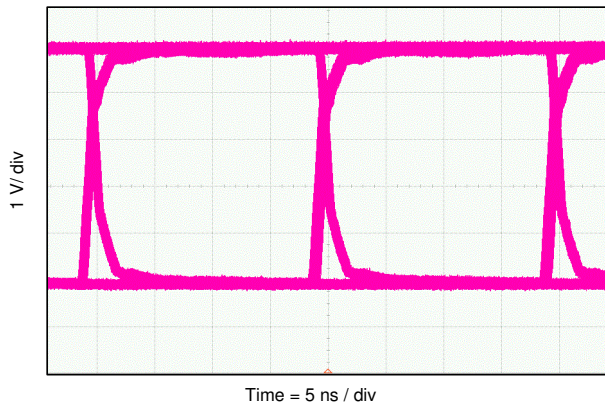
ADVANCE INFORMATION



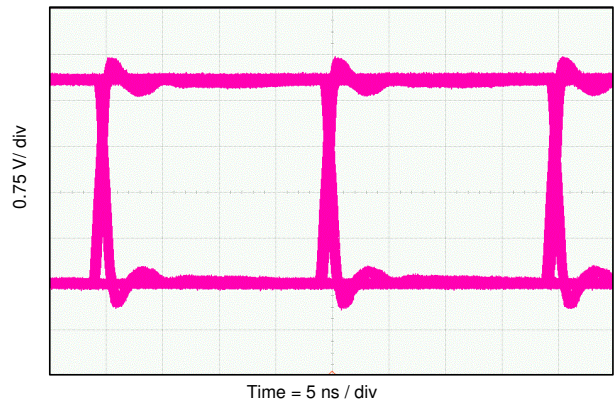
**Figure 9-2. Typical ISO674x Circuit Hook-up**

### 9.2.3 Application Curve

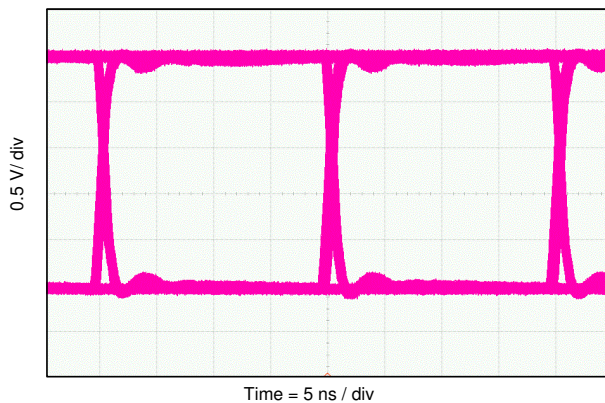
The following typical eye diagrams of the ISO674x family of devices indicates low jitter and wide open eye at the maximum data rate of 50 Mbps.



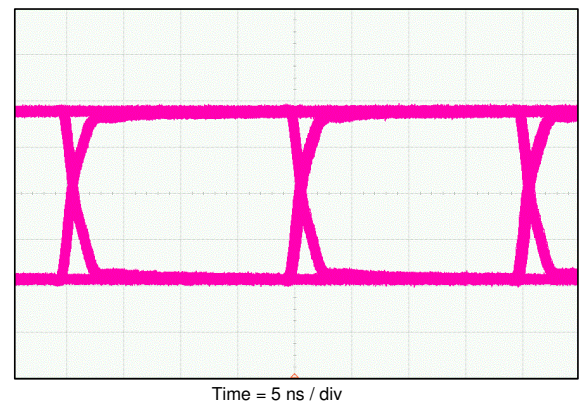
**Figure 9-3. Eye Diagram at 50 Mbps PRBS  $2^{16} - 1$ , 5 V and 25°C**



**Figure 9-4. Eye Diagram at 50 Mbps PRBS  $2^{16} - 1$ , 3.3 V and 25°C**



**Figure 9-5. Eye Diagram at 50 Mbps PRBS  $2^{16} - 1$ , 2.5 V and 25°C**



**Figure 9-6. Eye Diagram at 50 Mbps PRBS  $2^{16} - 1$ , 1.8 V and 25°C**

#### 9.2.3.1 Insulation Lifetime

Insulation lifetime projection data is collected by using industry-standard Time Dependent Dielectric Breakdown (TDDB) test method. In this test, all pins on each side of the barrier are tied together creating a two-terminal device and high voltage applied between the two sides; See [Figure 9-7](#) for TDDB test setup. The insulation breakdown data is collected at various high voltages switching at 60 Hz over temperature. For reinforced insulation, VDE standard requires the use of TDDB projection line with failure rate of less than 1 part per million (ppm). Even though the expected minimum insulation lifetime is 20 years at the specified working isolation voltage, VDE reinforced certification requires additional safety margin of 20% for working voltage and 87.5% for lifetime which translates into minimum required insulation lifetime of 37.5 years at a working voltage that's 20% higher than the specified value.

[Figure 9-8](#) shows the intrinsic capability of the isolation barrier to withstand high voltage stress over its lifetime. Based on the TDDB data, the intrinsic capability of the insulation is 1060 V<sub>RMS</sub> with a lifetime of 220 years. Other factors, such as package size, pollution degree, material group, etc. can further limit the working voltage of the component. The working voltage of DW-16 package is specified upto 1060 V<sub>RMS</sub>. At the lower working voltages, the corresponding insulation lifetime is much longer than 220 years.

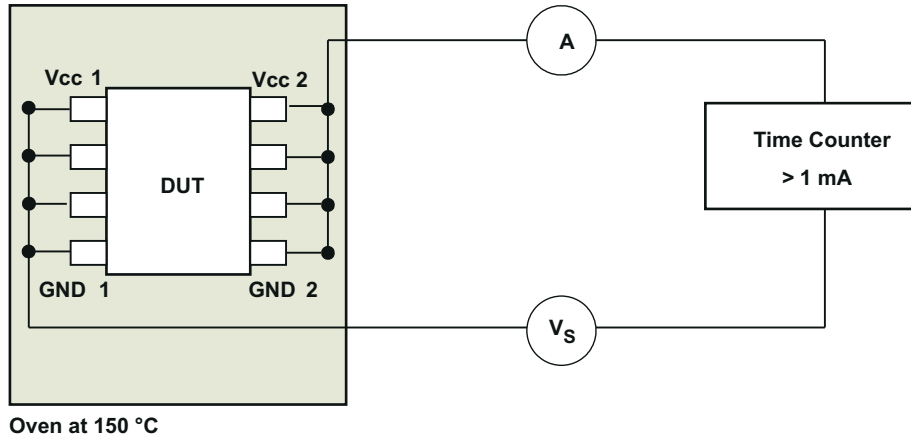


Figure 9-7. Test Setup for Insulation Lifetime Measurement

ADVANCE INFORMATION

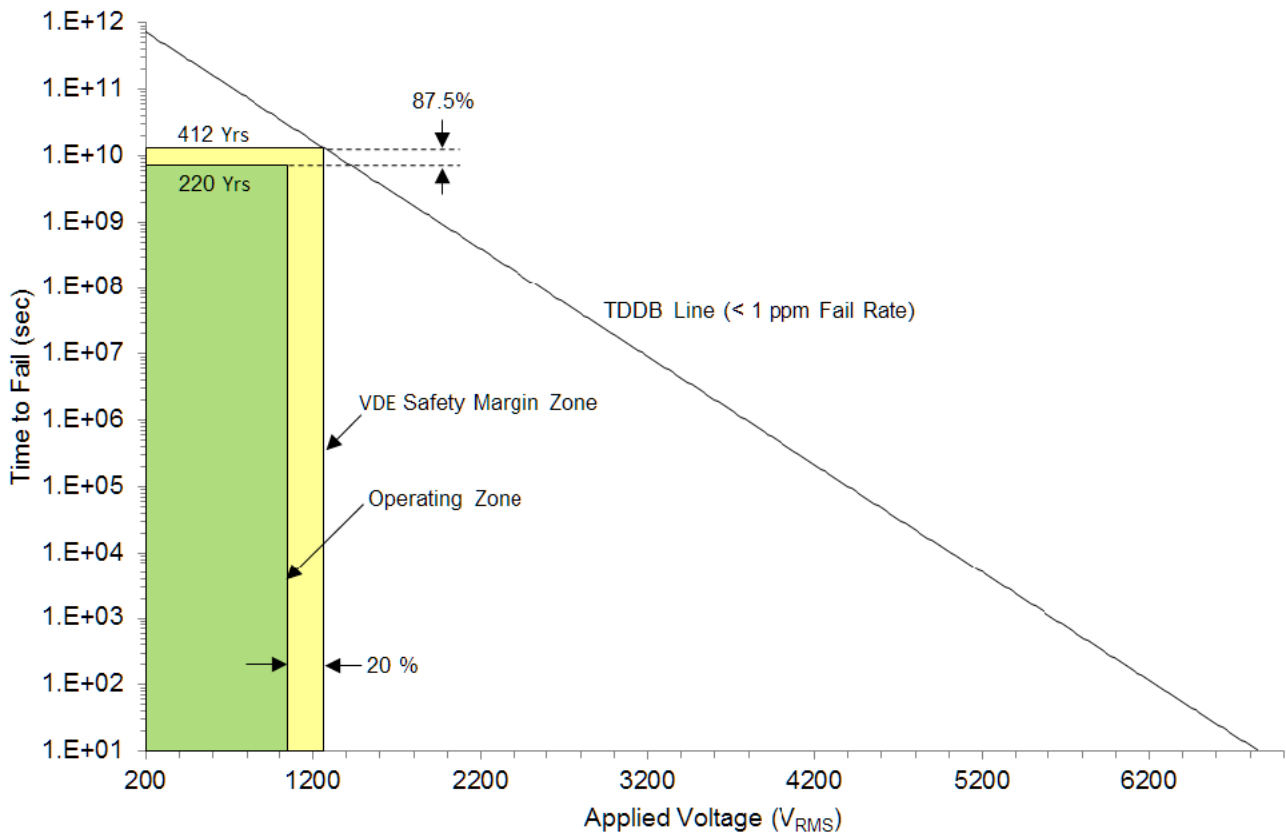


Figure 9-8. Insulation Lifetime Projection Data



## 10 Power Supply Recommendations

To help ensure reliable operation at data rates and supply voltages, a 0.1- $\mu$ F bypass capacitor is recommended at the input and output supply pins ( $V_{CC1}$  and  $V_{CC2}$ ). The capacitors should be placed as close to the supply pins as possible. If only a single primary-side power supply is available in an application, isolated power can be generated for the secondary-side with the help of a transformer driver. For industrial applications, please use Texas Instruments' [SN6501](#) or [SN6505A](#). For such applications, detailed power supply design and transformer selection recommendations are available in [SN6501 Transformer Driver for Isolated Power Supplies](#) or [SN6505 Low-Noise 1-A Transformer Drivers for Isolated Power Supplies](#).

## 11 Layout

### 11.1 Layout Guidelines

A minimum of two layers is required to accomplish a cost optimized and low EMI PCB design. To further improve EMI, a four layer board can be used (see [Figure 11-2](#)). Layer stacking for a four layer board should be in the following order (top-to-bottom): high-speed signal layer, ground plane, power plane and low-frequency signal layer.

- Routing the high-speed traces on the top layer avoids the use of vias (and the introduction of their inductances) and allows for clean interconnects between the isolator and the transmitter and receiver circuits of the data link.
- Placing a solid ground plane next to the high-speed signal layer establishes controlled impedance for transmission line interconnects and provides an excellent low-inductance path for the return current flow.
- Placing the power plane next to the ground plane creates additional high-frequency bypass capacitance of approximately 100 pF/inch<sup>2</sup>.
- Routing the slower speed control signals on the bottom layer allows for greater flexibility as these signal links usually have margin to tolerate discontinuities such as vias.

If an additional supply voltage plane or signal layer is needed, add a second power or ground plane system to the stack to keep it symmetrical. This makes the stack mechanically stable and prevents it from warping. Also the power and ground plane of each power system can be placed closer together, thus increasing the high-frequency bypass capacitance significantly.

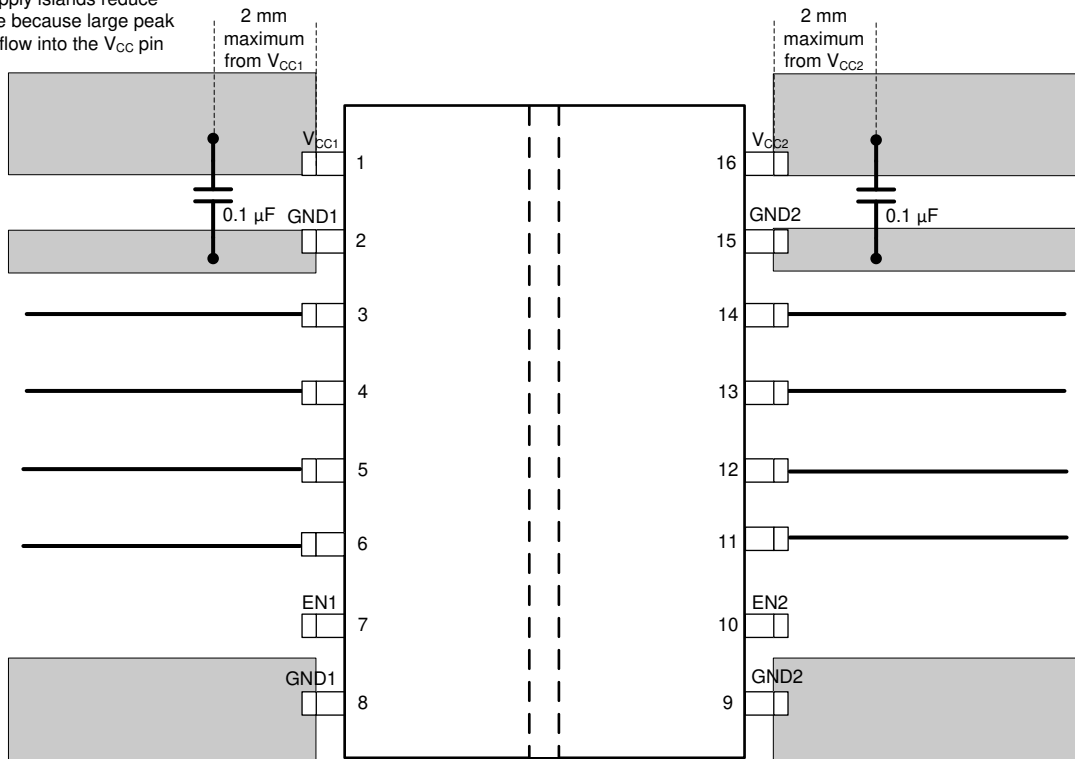
For detailed layout recommendations, refer to the [Digital Isolator Design Guide](#).

#### 11.1.1 PCB Material

For digital circuit boards operating below 150 Mbps, (or rise and fall times higher than 1 ns), and trace lengths of up to 10 inches, use standard FR-4 UL94V-0 printed circuit boards. This PCB is preferred over cheaper alternatives due to its lower dielectric losses at high frequencies, less moisture absorption, greater strength and stiffness, and self-extinguishing flammability-characteristics.

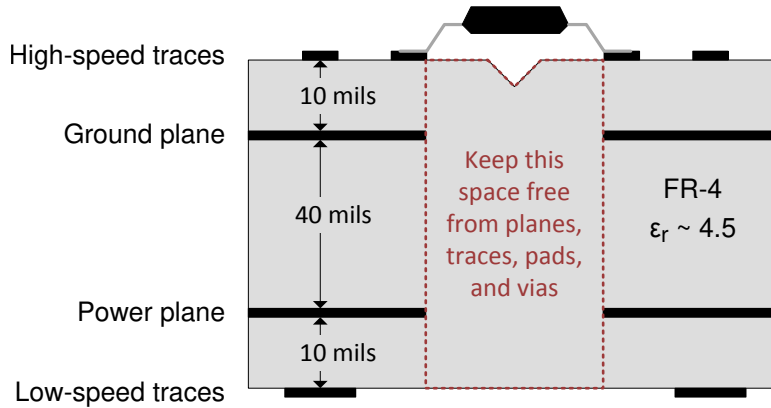
## 11.2 Layout Example

Solid supply islands reduce inductance because large peak currents flow into the  $V_{CC}$  pin



Solid ground islands help dissipate heat through PCB

**Figure 11-1. Layout Example**



**Figure 11-2. Layout Example Schematic**

## 12 Device and Documentation Support

### 12.1 Documentation Support

#### 12.1.1 Related Documentation

For related documentation, see the following:

- Texas Instruments, [Digital Isolator Design Guide](#)
- Texas Instruments, [Digital Isolator Design Guide](#)
- Texas Instruments, [Isolation Glossary](#)
- Texas Instruments, [How to use isolation to improve ESD, EFT, and Surge immunity in industrial systems application report](#)
- Texas Instruments, [ADS79xx 12/10/8-Bit, 1 MSPS, 16/12/8/4-Channel, Single-Ended, MicroPower, Serial Interface ADCs data sheet](#)
- Texas Instruments, [DAC161P997 Single-Wire 16-bit DAC for 4- to 20-mA Loops data sheet](#)
- Texas Instruments, [MSP430G2132 Mixed Signal Microcontroller data sheet](#)
- Texas Instruments, [SN6501 Transformer Driver for Isolated Power Supplies data sheet](#)
- Texas Instruments, [TPS76333 Low-Power 150-mA Low-Dropout Linear Regulators data sheet](#)

#### 12.2 Receiving Notification of Documentation Updates

To receive notification of documentation updates, navigate to the device product folder on ti.com. In the upper right corner, click on *Alert me* to register and receive a weekly digest of any product information that has changed. For change details, review the revision history included in any revised document.

#### 12.3 Support Resources

[TI E2E™ support forums](#) are an engineer's go-to source for fast, verified answers and design help — straight from the experts. Search existing answers or ask your own question to get the quick design help you need.

Linked content is provided "AS IS" by the respective contributors. They do not constitute TI specifications and do not necessarily reflect TI's views; see TI's [Terms of Use](#).

#### 12.4 Trademarks

TI E2E™ is a trademark of Texas Instruments.

All trademarks are the property of their respective owners.

#### 12.5 Electrostatic Discharge Caution



This integrated circuit can be damaged by ESD. Texas Instruments recommends that all integrated circuits be handled with appropriate precautions. Failure to observe proper handling and installation procedures can cause damage.

ESD damage can range from subtle performance degradation to complete device failure. Precision integrated circuits may be more susceptible to damage because very small parametric changes could cause the device not to meet its published specifications.

#### 12.6 Glossary

[TI Glossary](#) This glossary lists and explains terms, acronyms, and definitions.

## 13 Mechanical, Packaging, and Orderable Information

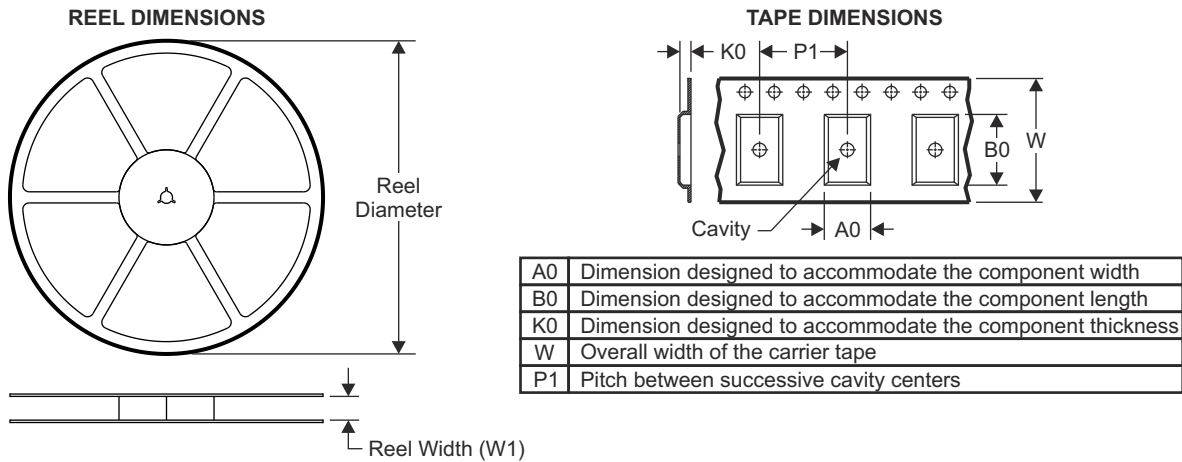
The following pages include mechanical packaging and orderable information. This information is the most current data available for the designated devices. This data is subject to change without notice and revision of this document. For browser-based versions of this data sheet, refer to the left-hand navigation.

## 13.1 Package Option Addendum

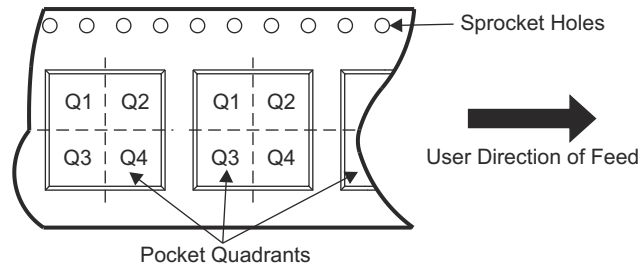
### Packaging Information

Orderable Device	Status <sup>(1)</sup>	Package Type	Package Drawing	Pins	Package Qty	Eco Plan <sup>(2)</sup>	Lead/Ball Finish <sup>(6)</sup>	MSL Peak Temp <sup>(3)</sup>	Op Temp (°C)	Device Marking <sup>(4) (5)</sup>
ISO6740DWR	ACTIVE	SOIC	DW	16	2000	Green (RoHS & no Sb/Br)	NIPDAU	Level-2-260C-1 YEAR	--40 to 125	ISO6740
ISO6740FDWR	ACTIVE	SOIC	DW	16	2000	Green (RoHS & no Sb/Br)	NIPDAU	Level-2-260C-1 YEAR	--40 to 125	ISO6740F
ISO6741DWR	ACTIVE	SOIC	DW	16	2000	Green (RoHS & no Sb/Br)	NIPDAU	Level-2-260C-1 YEAR	--40 to 125	ISO6741
ISO6741FDWR	ACTIVE	SOIC	DW	16	2000	Green (RoHS & no Sb/Br)	NIPDAU	Level-2-260C-1 YEAR	--40 to 125	ISO6741F
ISO6742DWR	ACTIVE	SOIC	DW	16	2000	Green (RoHS & no Sb/Br)	NIPDAU	Level-2-260C-1 YEAR	--40 to 125	ISO6742
ISO6742FDWR	ACTIVE	SOIC	DW	16	2000	Green (RoHS & no Sb/Br)	NIPDAU	Level-2-260C-1 YEAR	--40 to 125	ISO6742F

### 13.2 Tape and Reel Information



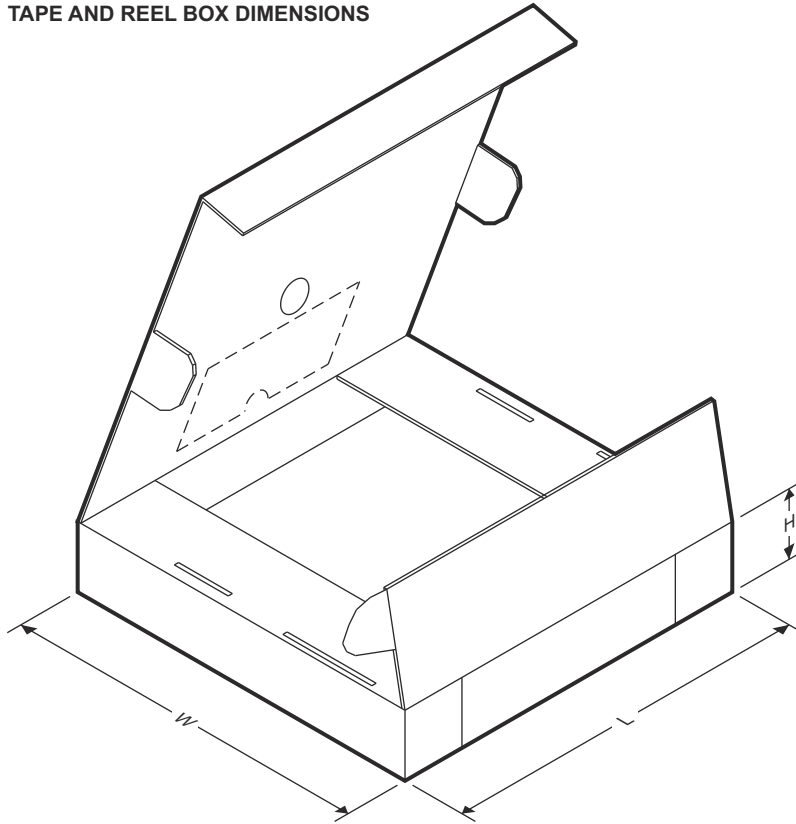
#### QUADRANT ASSIGNMENTS FOR PIN 1 ORIENTATION IN TAPE



Device	Package Type	Package Drawing	Pins	SPQ	Reel Diameter (mm)	Reel Width W1 (mm)	A0 (mm)	B0 (mm)	K0 (mm)	P1 (mm)	W (mm)	Pin1 Quadrant
ISO6740DWR	SOIC	DW	16	2000	330.0	24.4	10.9	10.7	2.7	12.0	24.0	Q1
ISO6740FDWR	SOIC	DW	16	2000	330.0	24.4	10.9	10.7	2.7	12.0	24.0	Q1
ISO6741DWR	SOIC	DW	16	2000	330.0	24.4	10.9	10.7	2.7	12.0	24.0	Q1
ISO6741FDWR	SOIC	DW	16	2000	330.0	24.4	10.9	10.7	2.7	12.0	24.0	Q1
ISO6742DWR	SOIC	DW	16	2000	330.0	24.4	10.9	10.7	2.7	12.0	24.0	Q1
ISO6742FDWR	SOIC	DW	16	2000	330.0	24.4	10.9	10.7	2.7	12.0	24.0	Q1

**ADVANCE INFORMATION**

**TAPE AND REEL BOX DIMENSIONS**



Device	Package Type	Package Drawing	Pins	SPQ	Length (mm)	Width (mm)	Height (mm)
ISO6740DWR	SOIC	DW	16	2000	367.0	367.0	45.0
ISO6740FDWR	SOIC	DW	16	2000	367.0	367.0	45.0
ISO6741DWR	SOIC	DW	16	2000	367.0	367.0	45.0
ISO6741FDWR	SOIC	DW	16	2000	367.0	367.0	45.0
ISO6742DWR	SOIC	DW	16	2000	367.0	367.0	45.0
ISO6742FDWR	SOIC	DW	16	2000	367.0	367.0	45.0

**ADVANCE INFORMATION**

## IMPORTANT NOTICE AND DISCLAIMER

TI PROVIDES TECHNICAL AND RELIABILITY DATA (INCLUDING DATASHEETS), DESIGN RESOURCES (INCLUDING REFERENCE DESIGNS), APPLICATION OR OTHER DESIGN ADVICE, WEB TOOLS, SAFETY INFORMATION, AND OTHER RESOURCES "AS IS" AND WITH ALL FAULTS, AND DISCLAIMS ALL WARRANTIES, EXPRESS AND IMPLIED, INCLUDING WITHOUT LIMITATION ANY IMPLIED WARRANTIES OF MERCHANTABILITY, FITNESS FOR A PARTICULAR PURPOSE OR NON-INFRINGEMENT OF THIRD PARTY INTELLECTUAL PROPERTY RIGHTS.

These resources are intended for skilled developers designing with TI products. You are solely responsible for (1) selecting the appropriate TI products for your application, (2) designing, validating and testing your application, and (3) ensuring your application meets applicable standards, and any other safety, security, or other requirements. These resources are subject to change without notice. TI grants you permission to use these resources only for development of an application that uses the TI products described in the resource. Other reproduction and display of these resources is prohibited. No license is granted to any other TI intellectual property right or to any third party intellectual property right. TI disclaims responsibility for, and you will fully indemnify TI and its representatives against, any claims, damages, costs, losses, and liabilities arising out of your use of these resources.

TI's products are provided subject to TI's Terms of Sale (<https://www.ti.com/legal/termsofsale.html>) or other applicable terms available either on [ti.com](https://www.ti.com) or provided in conjunction with such TI products. TI's provision of these resources does not expand or otherwise alter TI's applicable warranties or warranty disclaimers for TI products.

Mailing Address: Texas Instruments, Post Office Box 655303, Dallas, Texas 75265  
Copyright © 2021, Texas Instruments Incorporated