

IRFR4620PbF IRFU4620PbF

HEXFET® Power MOSFET

Applications

- High Efficiency Synchronous Rectification in SMPS
- Uninterruptible Power Supply
- High Speed Power Switching
- Hard Switched and High Frequency Circuits

Benefits

- Improved Gate, Avalanche and Dynamic dV/dt Ruggedness
- Fully Characterized Capacitance and Avalanche SOA
- Enhanced body diode dV/dt and dI/dt Capability
- Lead-Free

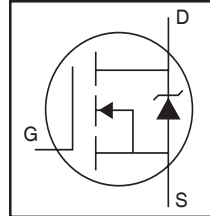

| | | |
|--------------|------|-------------|
| V_{DSS} | | 200V |
| $R_{DS(on)}$ | typ. | 64mΩ |
| | max. | 78mΩ |
| I_D | | 24A |

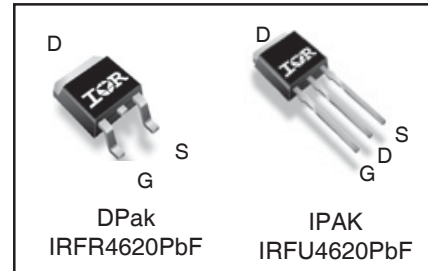

| | | |
|----------|----------|----------|
| G | D | S |
| Gate | Drain | Source |

Absolute Maximum Ratings

| Symbol | Parameter | Max. | Units |
|---------------------------------|--|--------------|-------|
| $I_D @ T_C = 25^\circ\text{C}$ | Continuous Drain Current, $V_{GS} @ 10\text{V}$ | 24 | A |
| $I_D @ T_C = 100^\circ\text{C}$ | Continuous Drain Current, $V_{GS} @ 10\text{V}$ | 17 | |
| I_{DM} | Pulsed Drain Current ① | 100 | |
| $P_D @ T_C = 25^\circ\text{C}$ | Maximum Power Dissipation | 144 | W |
| | Linear Derating Factor | 0.96 | W/°C |
| V_{GS} | Gate-to-Source Voltage | ± 20 | V |
| dv/dt | Peak Diode Recovery ③ | 54 | V/ns |
| T_J T_{STG} | Operating Junction and Storage Temperature Range | -55 to + 175 | °C |
| | Soldering Temperature, for 10 seconds (1.6mm from case) | 300 | |

Avalanche Characteristics

| | | | |
|------------------------------|---------------------------------|----------------------------|----|
| E_{AS} (Thermally limited) | Single Pulse Avalanche Energy ② | 113 | mJ |
| I_{AR} | Avalanche Current ① | See Fig. 14, 15, 22a, 22b, | A |
| E_{AR} | Repetitive Avalanche Energy ① | | mJ |

Thermal Resistance

| Symbol | Parameter | Typ. | Max. | Units |
|-----------------|-----------------------------------|------|-------|-------|
| $R_{\theta JC}$ | Junction-to-Case ⑧ | — | 1.045 | °C/W |
| $R_{\theta JA}$ | Junction-to-Ambient (PCB Mount) ⑦ | — | 50 | |
| $R_{\theta JA}$ | Junction-to-Ambient | — | 110 | |

ORDERING INFORMATION:

See detailed ordering and shipping information on the last page of this data sheet.

Notes ① through ⑧ are on page 11

Static @ $T_J = 25^\circ\text{C}$ (unless otherwise specified)

| Symbol | Parameter | Min. | Typ. | Max. | Units | Conditions |
|---------------------------------|--------------------------------------|------|------|------|---------------------|---|
| $V_{(BR)DSS}$ | Drain-to-Source Breakdown Voltage | 200 | — | — | V | $V_{GS} = 0V, I_D = 250\mu A$ |
| $\Delta V_{(BR)DSS}/\Delta T_J$ | Breakdown Voltage Temp. Coefficient | — | 0.23 | — | V/ $^\circ\text{C}$ | Reference to 25°C , $I_D = 5mA$ ① |
| $R_{DS(on)}$ | Static Drain-to-Source On-Resistance | — | 64 | 78 | m Ω | $V_{GS} = 10V, I_D = 15A$ ④ |
| $V_{GS(th)}$ | Gate Threshold Voltage | 3.0 | — | 5.0 | V | $V_{DS} = V_{GS}, I_D = 100\mu A$ |
| I_{DSS} | Drain-to-Source Leakage Current | — | — | 20 | μA | $V_{DS} = 200V, V_{GS} = 0V$ |
| | | — | — | 250 | | $V_{DS} = 200V, V_{GS} = 0V, T_J = 125^\circ\text{C}$ |
| I_{GSS} | Gate-to-Source Forward Leakage | — | — | 100 | nA | $V_{GS} = 20V$ |
| | Gate-to-Source Reverse Leakage | — | — | -100 | | $V_{GS} = -20V$ |
| $R_{G(int)}$ | Internal Gate Resistance | — | 2.6 | — | Ω | |

Dynamic @ $T_J = 25^\circ\text{C}$ (unless otherwise specified)

| Symbol | Parameter | Min. | Typ. | Max. | Units | Conditions |
|-----------------------------|--|------|------|------|-------|---|
| gfs | Forward Transconductance | 37 | — | — | S | $V_{DS} = 50V, I_D = 15A$ |
| Q_g | Total Gate Charge | — | 25 | 38 | nC | $I_D = 15A$ |
| Q_{gs} | Gate-to-Source Charge | — | 8.2 | — | | $V_{DS} = 100V$ |
| Q_{gd} | Gate-to-Drain ("Miller") Charge | — | 7.9 | — | | $V_{GS} = 10V$ ④ |
| Q_{sync} | Total Gate Charge Sync. ($Q_g - Q_{gd}$) | — | 17 | — | | $I_D = 15A, V_{DS} = 0V, V_{GS} = 10V$ |
| $t_{d(on)}$ | Turn-On Delay Time | — | 13.4 | — | ns | $V_{DD} = 130V$ |
| t_r | Rise Time | — | 22.4 | — | | $I_D = 15A$ |
| $t_{d(off)}$ | Turn-Off Delay Time | — | 25.4 | — | | $R_G = 7.3\Omega$ |
| t_f | Fall Time | — | 14.8 | — | | $V_{GS} = 10V$ ④ |
| C_{iss} | Input Capacitance | — | 1710 | — | pF | $V_{GS} = 0V$ |
| C_{oss} | Output Capacitance | — | 125 | — | | $V_{DS} = 50V$ |
| C_{rss} | Reverse Transfer Capacitance | — | 30 | — | | $f = 1.0\text{MHz}$ (See Fig.5) |
| $C_{oss \text{ eff. (ER)}}$ | Effective Output Capacitance (Energy Related)⑥ | — | 113 | — | | $V_{GS} = 0V, V_{DS} = 0V \text{ to } 160V$ ⑥(See Fig.11) |
| $C_{oss \text{ eff. (TR)}}$ | Effective Output Capacitance (Time Related)⑤ | — | 317 | — | | $V_{GS} = 0V, V_{DS} = 0V \text{ to } 160V$ ⑤ |

Diode Characteristics

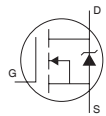
| Symbol | Parameter | Min. | Typ. | Max. | Units | Conditions |
|-----------|---|--|------|------|-------|--|
| I_S | Continuous Source Current (Body Diode) | — | — | 24 | A | MOSFET symbol showing the integral reverse p-n junction diode.  |
| I_{SM} | Pulsed Source Current (Body Diode) ① | — | — | 100 | | |
| V_{SD} | Diode Forward Voltage | — | — | 1.3 | V | $T_J = 25^\circ\text{C}, I_S = 15A, V_{GS} = 0V$ ④ |
| t_{rr} | Reverse Recovery Time | — | 78 | — | ns | $T_J = 25^\circ\text{C}$ $V_R = 100V,$ |
| | | — | 99 | — | | $T_J = 125^\circ\text{C}$ $I_F = 15A$ |
| Q_{rr} | Reverse Recovery Charge | — | 294 | — | nC | $T_J = 25^\circ\text{C}$ $di/dt = 100A/\mu s$ ④ |
| | | — | 432 | — | | $T_J = 125^\circ\text{C}$ |
| I_{RRM} | Reverse Recovery Current | — | 7.6 | — | A | $T_J = 25^\circ\text{C}$ |
| t_{on} | Forward Turn-On Time | Intrinsic turn-on time is negligible (turn-on is dominated by LS+LD) | | | | |

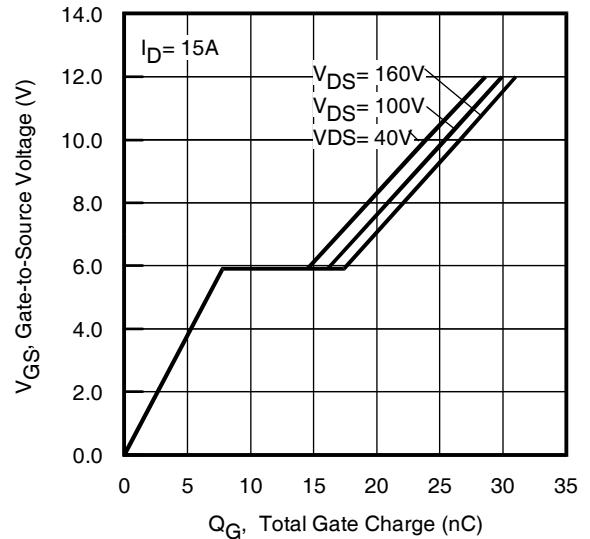
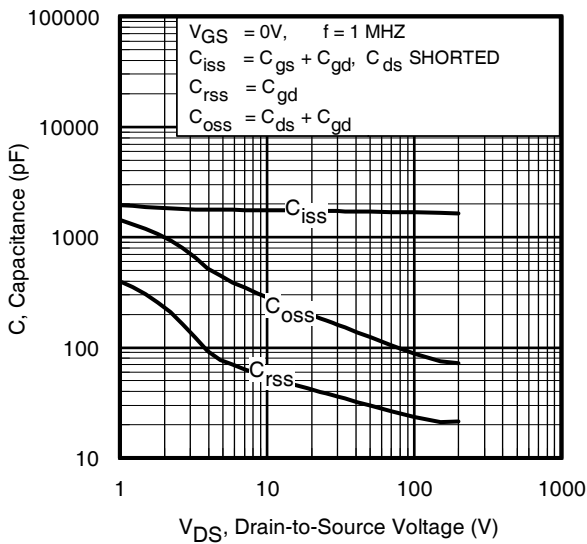
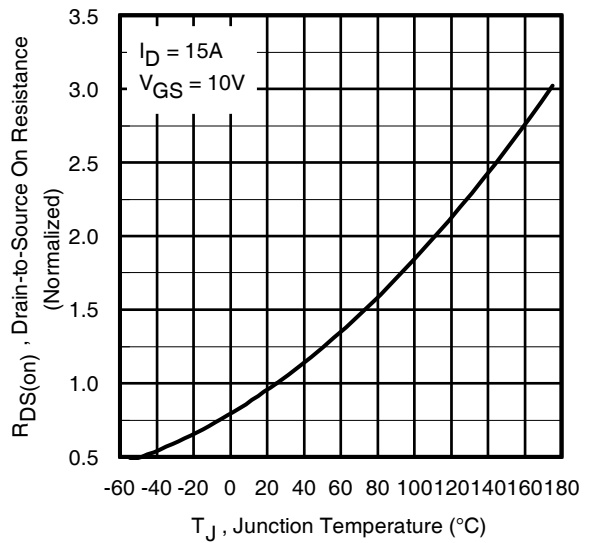
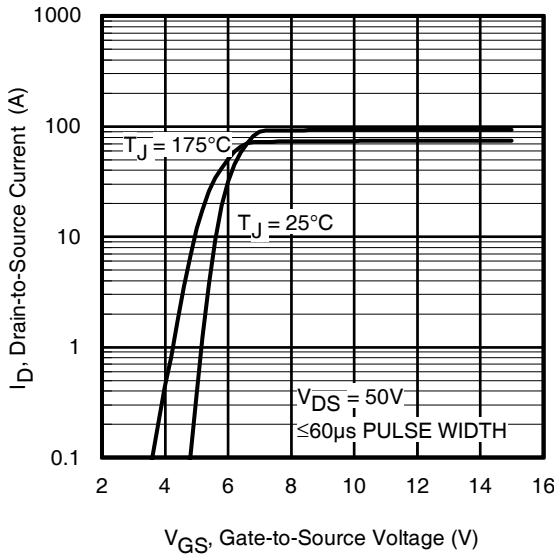
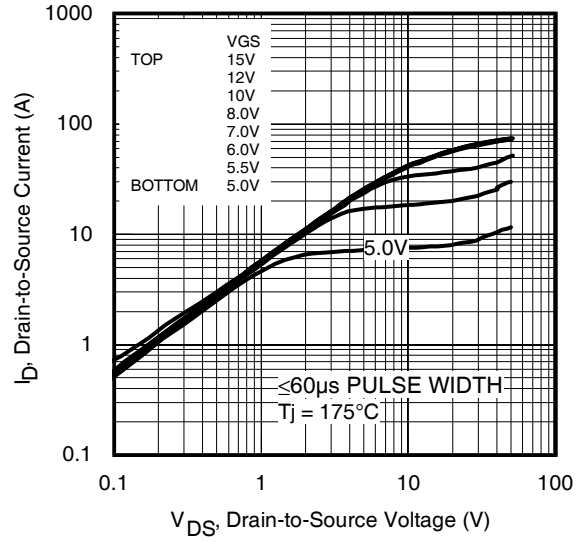

Fig 5. Typical Capacitance vs. Drain-to-Source Voltage

Fig 6. Typical Gate Charge vs. Gate-to-Source Voltage



Fig 7. Typical Source-Drain Diode Forward Voltage

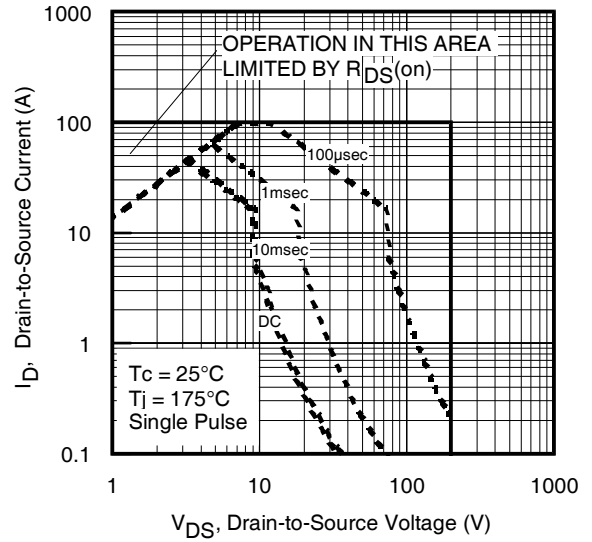

Fig 8. Maximum Safe Operating Area

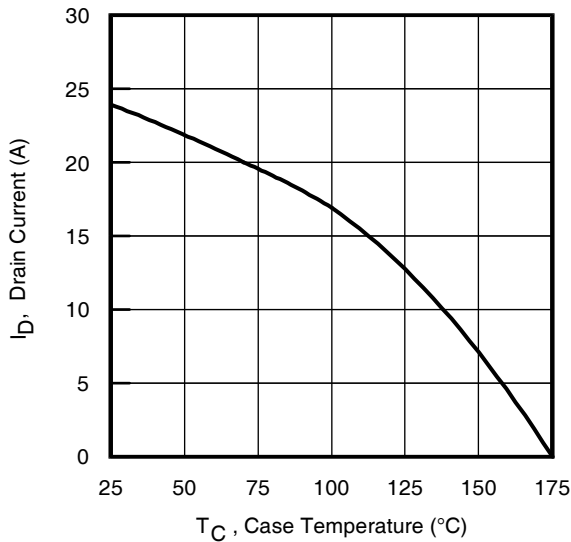

Fig 9. Maximum Drain Current vs. Case Temperature

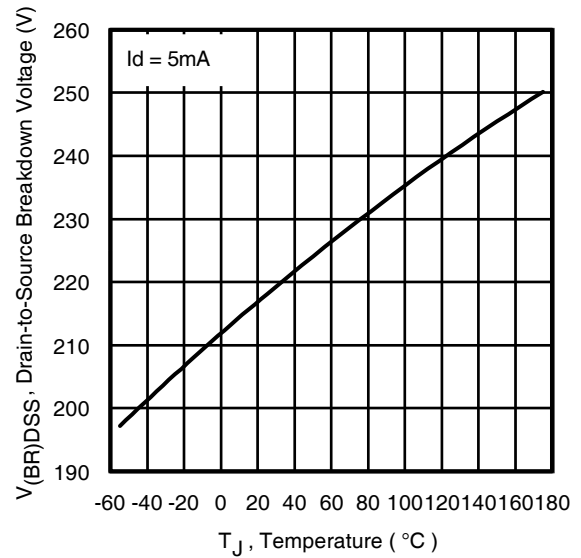

Fig 10. Drain-to-Source Breakdown Voltage

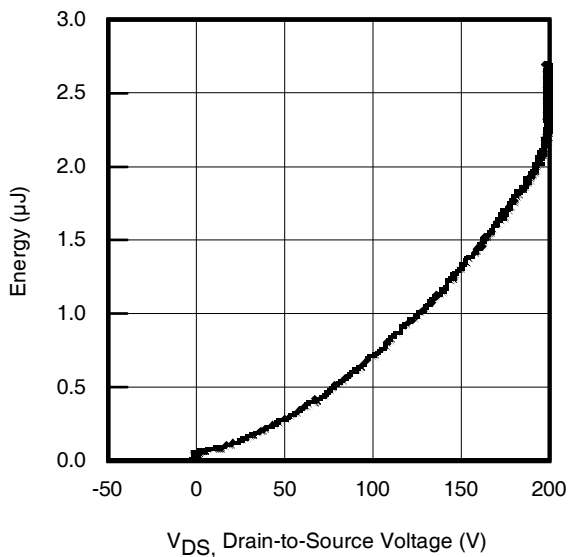

Fig 11. Typical C_{OSS} Stored Energy

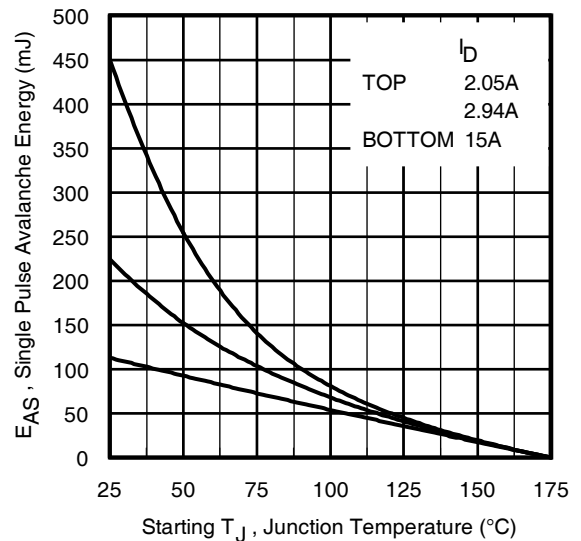

Fig 12. Maximum Avalanche Energy vs. Drain Current



Fig 13. Maximum Effective Transient Thermal Impedance, Junction-to-Case

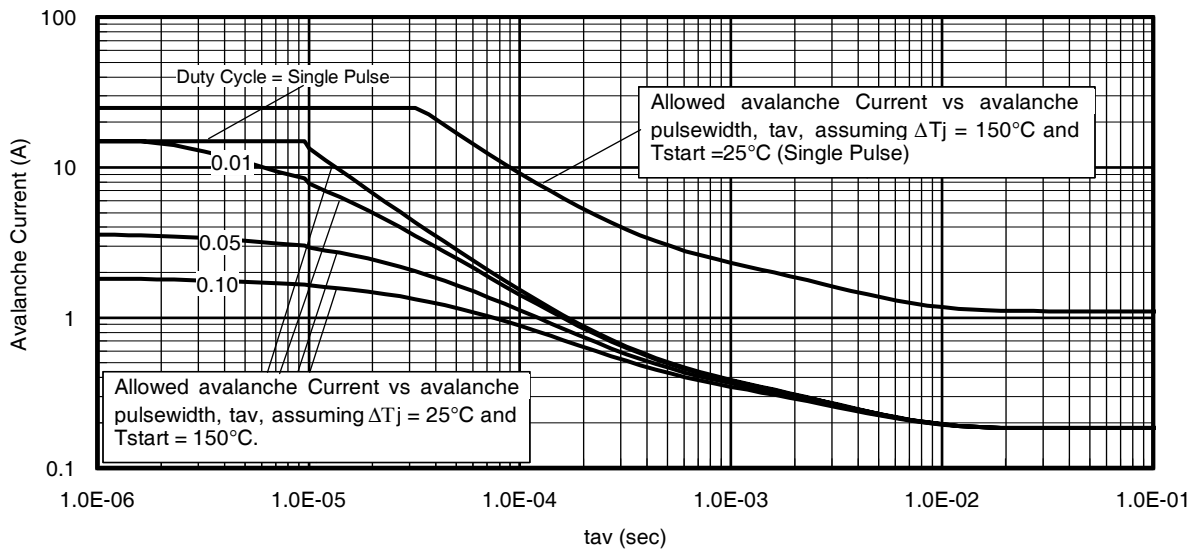
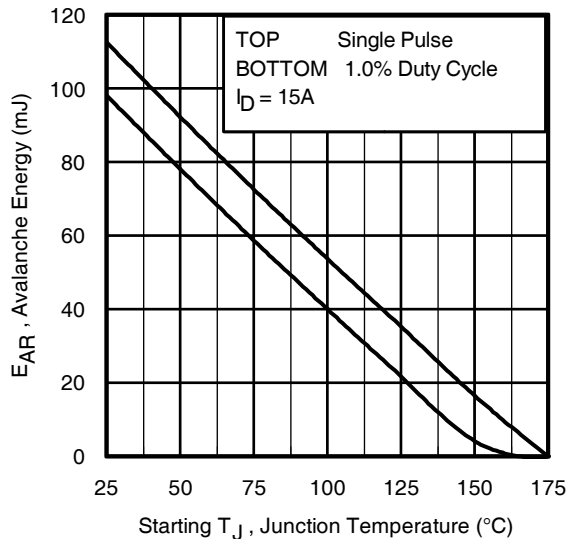

Fig 14. Typical Avalanche Current vs. Pulsewidth



Notes on Repetitive Avalanche Curves, Figures 14, 15:
(For further info, see AN-1005 at www.irf.com)

1. Avalanche failures assumption:
Purely a thermal phenomenon and failure occurs at a temperature far in excess of T_{jmax} . This is validated for every part type.
2. Safe operation in Avalanche is allowed as long as T_{jmax} is not exceeded.
3. Equation below based on circuit and waveforms shown in Figures 16a, 16b.
4. $P_{D(ave)}$ = Average power dissipation per single avalanche pulse.
5. BV = Rated breakdown voltage (1.3 factor accounts for voltage increase during avalanche).
6. I_{av} = Allowable avalanche current.
7. ΔT = Allowable rise in junction temperature, not to exceed T_{jmax} (assumed as 25°C in Figure 14, 15).
 t_{av} = Average time in avalanche.
 D = Duty cycle in avalanche = $t_{av} \cdot f$
 $Z_{thJC}(D, t_{av})$ = Transient thermal resistance, see Figures 13)

$$P_{D(ave)} = 1/2 (1.3 \cdot BV \cdot I_{av}) = \Delta T / Z_{thJC}$$

$$I_{av} = 2\Delta T / [1.3 \cdot BV \cdot Z_{th}]$$

$$E_{AS(AR)} = P_{D(ave)} \cdot t_{av}$$

Fig 15. Maximum Avalanche Energy vs. Temperature

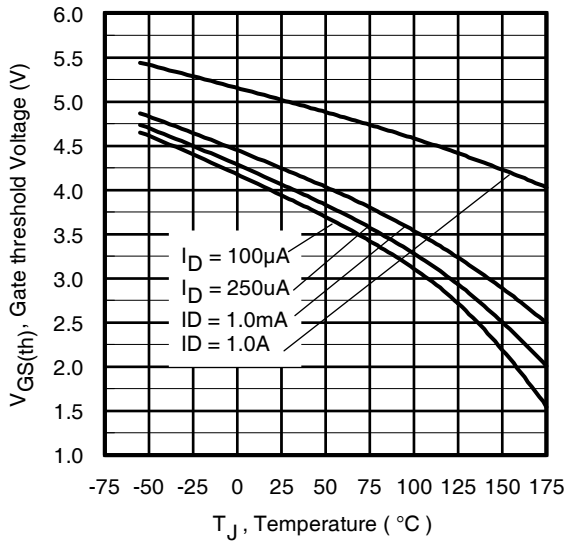

Fig 16. Threshold Voltage vs. Temperature

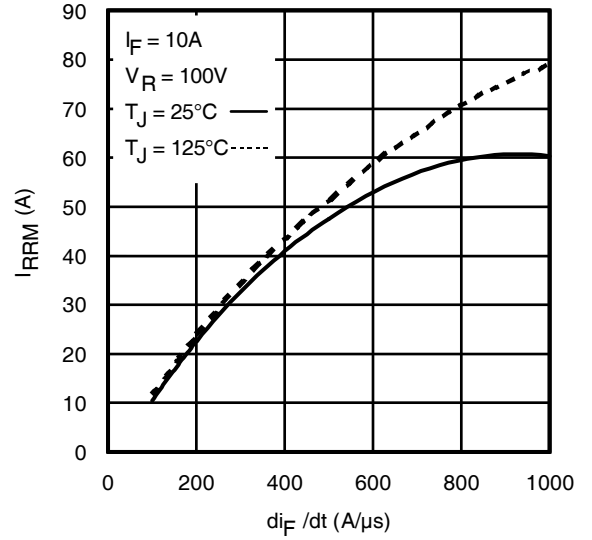

Fig. 17 - Typical Recovery Current vs. di_F/dt

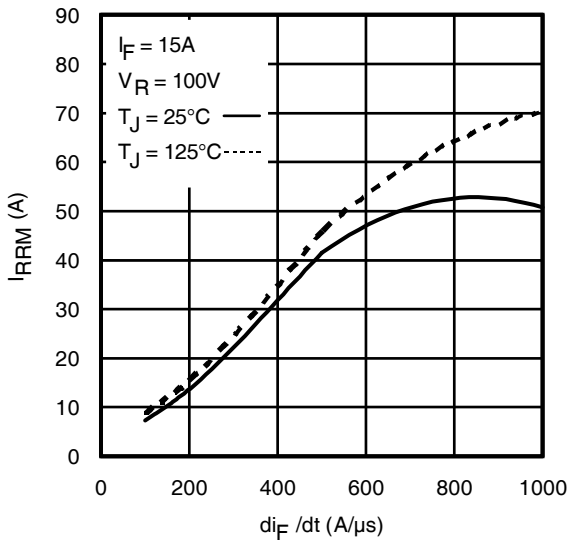

Fig. 18 - Typical Recovery Current vs. di_F/dt

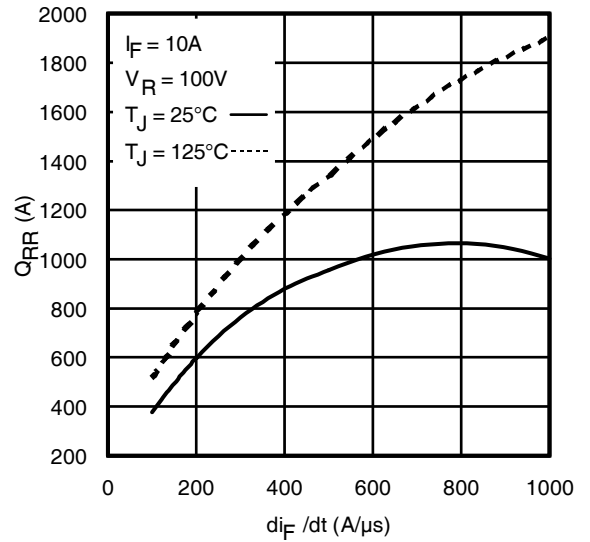

Fig. 19 - Typical Stored Charge vs. di_F/dt

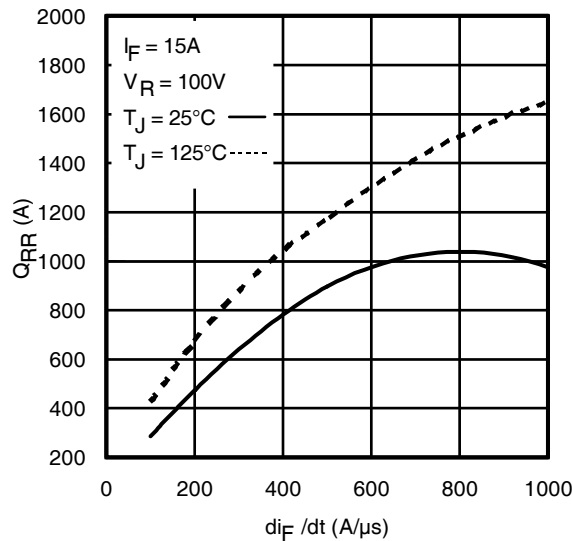

Fig. 20 - Typical Stored Charge vs. di_F/dt



Fig 21. Peak Diode Recovery dv/dt Test Circuit for N-Channel HEXFET® Power MOSFETs



* $V_{GS} = 5V$ for Logic Level Devices

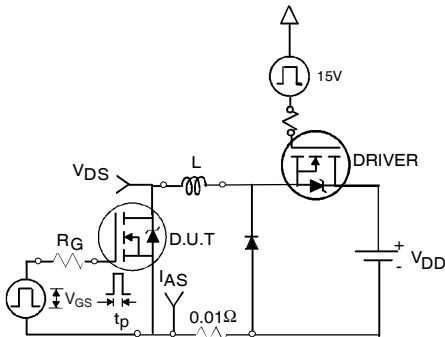

Fig 22a. Unclamped Inductive Test Circuit



Fig 22b. Unclamped Inductive Waveforms



Fig 23a. Switching Time Test Circuit



Fig 23b. Switching Time Waveforms



Fig 24a. Gate Charge Test Circuit



Fig 24b. Gate Charge Waveform

D-Pak (TO-252AA) Package Outline

Dimensions are shown in millimeters (inches)

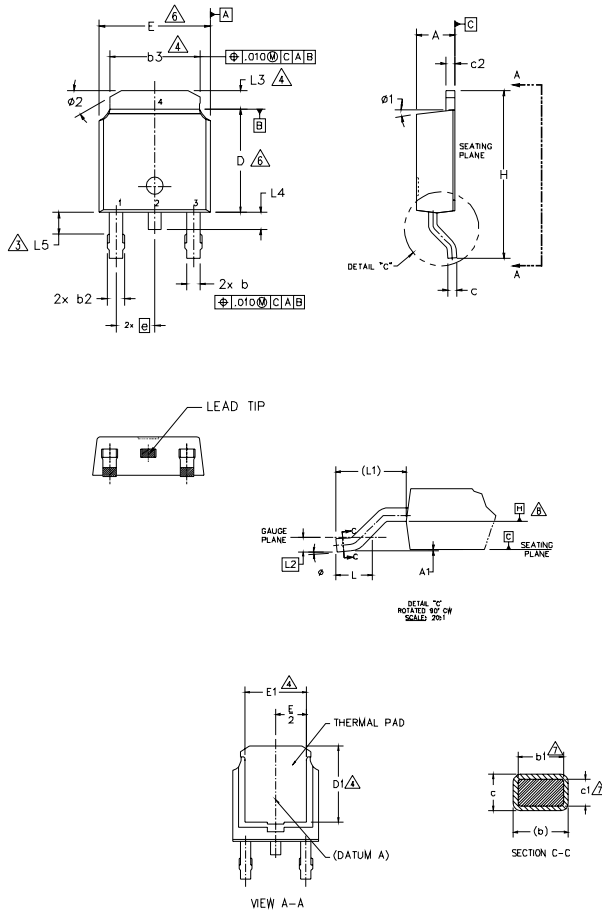

NOTES:

- 1.- DIMENSIONING AND TOLERANCING PER ASME Y14.5M-1994
- 2.- DIMENSIONS ARE SHOWN IN INCHES [MILLIMETERS].
- △- LEAD DIMENSION UNCONTROLLED IN L5.
- △- DIMENSION D1, E1, L3 & b3 ESTABLISH A MINIMUM MOUNTING SURFACE FOR THERMAL PAD.
- 5.- SECTION C-C DIMENSIONS APPLY TO THE FLAT SECTION OF THE LEAD BETWEEN .005 AND 0.10 [0.13 AND 0.25] FROM THE LEAD TIP.
- △- DIMENSION D & E DO NOT INCLUDE MOLD FLASH. MOLD FLASH SHALL NOT EXCEED .005 [0.13] PER SIDE. THESE DIMENSIONS ARE MEASURED AT THE OUTMOST EXTREMES OF THE PLASTIC BODY.
- △- DIMENSION b1 & c1 APPLIED TO BASE METAL ONLY.
- △- DATUM A & B TO BE DETERMINED AT DATUM PLANE H.
- 9.- OUTLINE CONFORMS TO JEDEC OUTLINE TO-252AA.

| SYMBOL | DIMENSIONS | | | | NOTES | |
|--------|-------------|-------|-----------|------|------------------|---|
| | MILLIMETERS | | INCHES | | | |
| | MIN. | MAX. | MIN. | MAX. | | |
| A | 2.18 | 2.39 | .086 | .094 | LEAD ASSIGNMENTS | |
| A1 | - | 0.13 | - | .005 | | |
| b | 0.64 | 0.89 | .025 | .035 | | |
| b1 | 0.65 | 0.79 | .025 | .031 | | 7 |
| b2 | 0.76 | 1.14 | .030 | .045 | | |
| b3 | 4.95 | 5.46 | .195 | .215 | | 4 |
| c | 0.46 | 0.61 | .018 | .024 | | |
| c1 | 0.41 | 0.56 | .016 | .022 | | 7 |
| c2 | 0.46 | 0.89 | .018 | .035 | | |
| D | 5.97 | 6.22 | .235 | .245 | | 6 |
| D1 | 5.21 | - | .205 | - | | 4 |
| E | 6.35 | 6.73 | .250 | .265 | | 6 |
| E1 | 4.32 | - | .170 | - | 4 | |
| e | 2.29 BSC | | .090 BSC | | HEXFET | |
| H | 9.40 | 10.41 | .370 | .410 | | |
| L | 1.40 | 1.78 | .055 | .070 | | |
| L1 | 2.74 BSC | | .108 REF. | | | |
| L2 | 0.51 BSC | | .020 BSC | | IGBT & CoPAK | |
| L3 | 0.89 | 1.27 | .035 | .050 | | |
| L4 | - | 1.02 | - | .040 | | |
| L5 | 1.14 | 1.52 | .045 | .060 | | |
| Ø | 0" | 10" | 0" | 10" | | |
| Ø1 | 0" | 15" | 0" | 15" | | |
| Ø2 | 25" | 35" | 25" | 35" | | |

LEAD ASSIGNMENTS

- HEXFET**
- 1.- GATE
 - 2.- DRAIN
 - 3.- SOURCE
 - 4.- DRAIN

IGBT & CoPAK

- 1.- GATE
- 2.- COLLECTOR
- 3.- EMITTER
- 4.- COLLECTOR

D-Pak (TO-252AA) Part Marking Information

EXAMPLE: THIS IS AN IRFR120 WITH ASSEMBLY LOT CODE 1234 ASSEMBLED ON WW 16, 2001 IN THE ASSEMBLY LINE 'A'

Note: 'P' in assembly line position indicates 'Lead-Free'
'P' in assembly line position indicates 'Lead-Free' qualification to the consumer-level

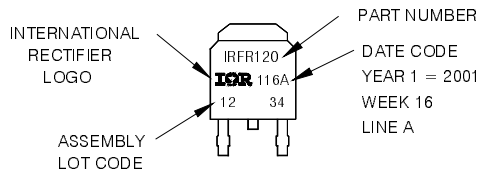

OR

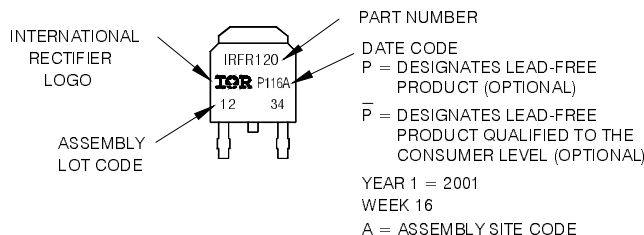

P = DESIGNATES LEAD-FREE PRODUCT (OPTIONAL)
P̄ = DESIGNATES LEAD-FREE PRODUCT QUALIFIED TO THE CONSUMER LEVEL (OPTIONAL)
YEAR 1 = 2001
WEEK 16
A = ASSEMBLY SITE CODE

Note: For the most current drawing please refer to IR website at <http://www.irf.com/package/>

I-Pak (TO-251AA) Package Outline

Dimensions are shown in millimeters (inches)

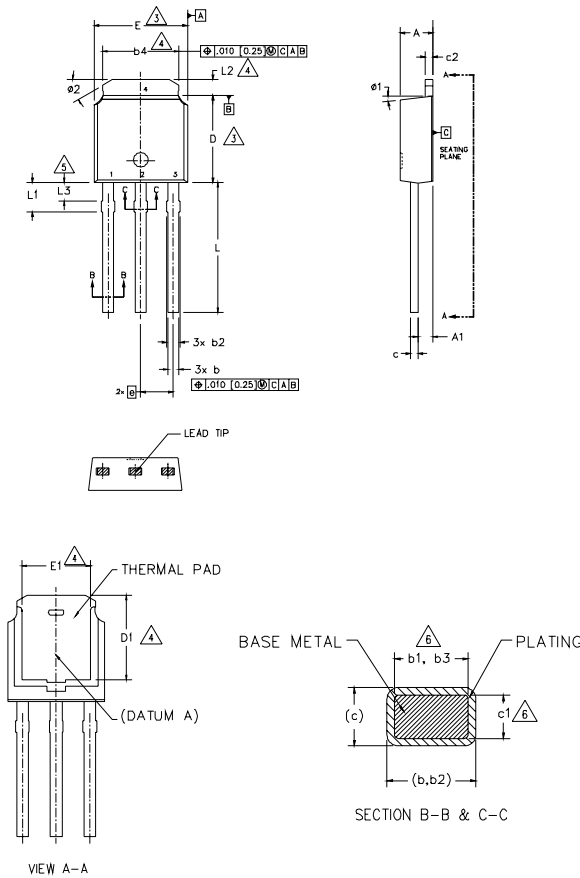

NOTES:

- 1.- DIMENSIONING AND TOLERANCING PER ASME Y14.5M-1994
- 2.- DIMENSION ARE SHOWN IN INCHES [MILLIMETERS].
- △ DIMENSION D & E DO NOT INCLUDE MOLD FLASH. MOLD FLASH SHALL NOT EXCEED .005 [0.13] PER SIDE. THESE DIMENSIONS ARE MEASURED AT THE OUTMOST EXTREMES OF THE PLASTIC BODY.
- △ THERMAL PAD CONTOUR OPTION WITHIN DIMENSION b4, L2, E1 & D1.
- △ LEAD DIMENSION UNCONTROLLED IN L3.
- △ DIMENSION b1, b3 & c1 APPLY TO BASE METAL ONLY.
- 7.- OUTLINE CONFORMS TO JEDEC OUTLINE TO-251AA (Date 06/02).
- 8.- CONTROLLING DIMENSION : INCHES.

| SYM- BOL | DIMENSIONS | | | | NOTES |
|-------------|-------------|------|----------|------|-------|
| | MILLIMETERS | | INCHES | | |
| | MIN. | MAX. | MIN. | MAX. | |
| A | 2.18 | 2.39 | .086 | .094 | 6 |
| A1 | 0.89 | 1.14 | .035 | .045 | |
| b | 0.64 | 0.89 | .025 | .035 | 6 |
| b1 | 0.65 | 0.79 | .025 | .031 | |
| b2 | 0.76 | 1.14 | .030 | .045 | 4 |
| b3 | 0.76 | 1.04 | .030 | .041 | |
| b4 | 4.95 | 5.46 | .195 | .215 | 6 |
| c | 0.46 | 0.61 | .018 | .024 | |
| c1 | 0.41 | 0.56 | .016 | .022 | 6 |
| c2 | 0.46 | 0.89 | .018 | .035 | |
| D | 5.97 | 6.22 | .235 | .245 | 3 |
| D1 | 5.21 | - | .205 | - | |
| E | 6.35 | 6.73 | .250 | .265 | 3 |
| E1 | 4.32 | - | .170 | - | |
| e | 2.29 BSC | | .090 BSC | | 4 |
| L | 8.89 | 9.65 | .350 | .380 | |
| L1 | 1.91 | 2.29 | .045 | .090 | 5 |
| L2 | 0.89 | 1.27 | .035 | .050 | |
| L3 | 1.14 | 1.52 | .045 | .060 | 5 |
| ∅1 | 0" | 15" | 0" | 15" | |
| ∅2 | 25" | 35" | 25" | 35" | |

LEAD ASSIGNMENTS

HEXFET

- 1.- GATE
- 2.- DRAIN
- 3.- SOURCE
- 4.- DRAIN

I-Pak (TO-251AA) Part Marking Information

EXAMPLE: THIS IS AN IRFU120
WITH ASSEMBLY
LOT CODE 5678
ASSEMBLED ON WW 19, 2001
IN THE ASSEMBLY LINE 'A'

Note: 'P' in assembly line position
indicates Lead-Free'

OR

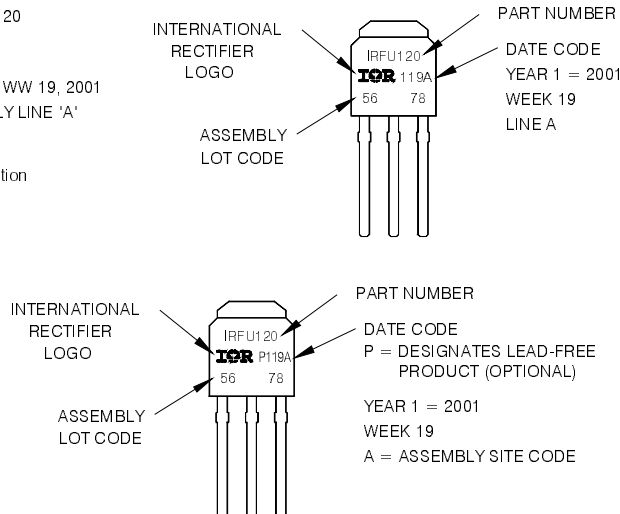

**Note: For the most current drawing please refer to IR website at <http://www.irf.com/package/>
www.irf.com**

D-Pak (TO-252AA) Tape & Reel Information

Dimensions are shown in millimeters (inches)

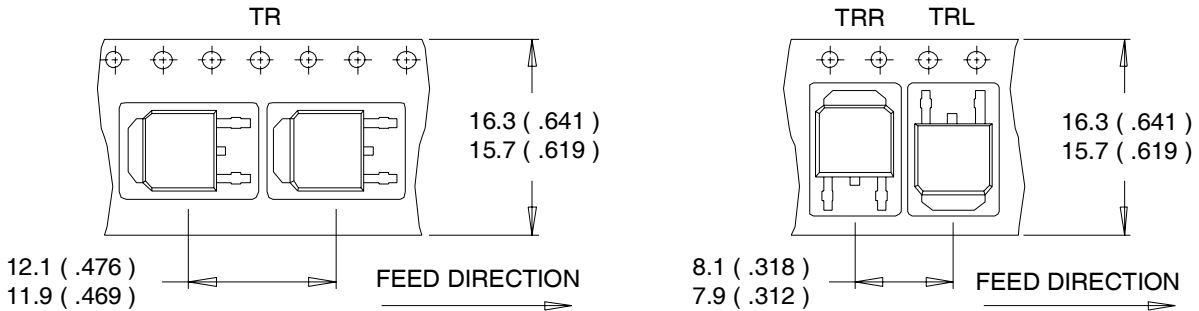

NOTES :

1. CONTROLLING DIMENSION : MILLIMETER.
2. ALL DIMENSIONS ARE SHOWN IN MILLIMETERS (INCHES).
3. OUTLINE CONFORMS TO EIA-481 & EIA-541.

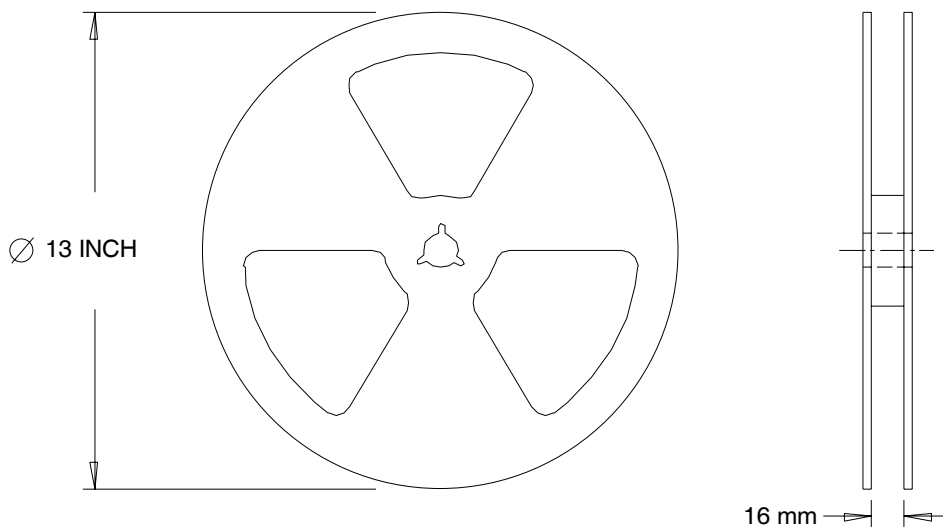

NOTES :

1. OUTLINE CONFORMS TO EIA-481.

Note: For the most current drawing please refer to IR website at <http://www.irf.com/package/>

| Orderable part number | Package Type | Standard Pack | | Note |
|-----------------------|--------------|---------------|----------|------|
| | | Form | Quantity | |
| IRFR4620PbF | D-PAK | Tube/Bulk | 75 | |
| IRFR4620TRPbF | D-PAK | Tape and Reel | 2000 | |
| IRFU4620PbF | I-PAK | Tube/Bulk | 75 | |

Qualification Information[†]

| | | |
|----------------------------|--|--|
| Qualification level | Industrial ^{††} | |
| | (per JEDEC JESD47F ^{†††} guidelines) | |
| | Comments: This family of products has passed JEDEC's Industrial qualification. IR's Consumer qualification level is granted by extension of the higher Industrial level. | |
| Moisture Sensitivity Level | D-PAK | MSL1 (per JEDEC J-STD-020D ^{†††}) |
| | I-PAK | Not applicable |
| RoHS Compliant | Yes | |

† Qualification standards can be found at International Rectifier's web site <http://www.irf.com/product-info/reliability>

†† Higher qualification ratings may be available should the user have such requirements. Please contact

your International Rectifier sales representative for further information: <http://www.irf.com/whoto-call/salesrep/>

††† Applicable version of JEDEC standard at the time of product release.

Notes:

- ① Repetitive rating; pulse width limited by max. junction temperature.
- ② Limited by T_{Jmax} , starting $T_J = 25^\circ\text{C}$, $L = 1.0\text{mH}$
 $R_G = 25\Omega$, $I_{AS} = 15\text{A}$, $V_{GS} = 10\text{V}$. Part not recommended for use above this value.
- ③ $I_{SD} \leq 15\text{A}$, $di/dt \leq 634\text{A}/\mu\text{s}$, $V_{DD} \leq V_{(BR)DSS}$, $T_J \leq 175^\circ\text{C}$.
- ④ Pulse width $\leq 400\mu\text{s}$; duty cycle $\leq 2\%$.
- ⑤ C_{oss} eff. (TR) is a fixed capacitance that gives the same charging time as C_{oss} while V_{DS} is rising from 0 to 80% V_{DSS} .
- ⑥ C_{oss} eff. (ER) is a fixed capacitance that gives the same energy as C_{oss} while V_{DS} is rising from 0 to 80% V_{DSS} .
- ⑦ When mounted on 1" square PCB (FR-4 or G-10 Material). For recommended footprint and soldering techniques refer to application note #AN-994.
- ⑧ R_θ is measured at T_J approximately 90°C

Data and specifications subject to change without notice

International
IR Rectifier

IR WORLD HEADQUARTERS: 233 Kansas St., El Segundo, California 90245, USA Tel: (310) 252-7105

TAC Fax: (310) 252-7903

Visit us at www.irf.com for sales contact information. 06/2009