

## Important notice

Dear Customer,

On 7 February 2017 the former NXP Standard Product business became a new company with the tradename **Nexperia**. Nexperia is an industry leading supplier of Discrete, Logic and PowerMOS semiconductors with its focus on the automotive, industrial, computing, consumer and wearable application markets

In data sheets and application notes which still contain NXP or Philips Semiconductors references, use the references to Nexperia, as shown below.

Instead of <http://www.nxp.com>, <http://www.philips.com/> or <http://www.semiconductors.philips.com/>, use <http://www.nexperia.com>

Instead of [sales.addresses@www.nxp.com](mailto:sales.addresses@www.nxp.com) or [sales.addresses@www.semiconductors.philips.com](mailto:sales.addresses@www.semiconductors.philips.com), use [salesaddresses@nexperia.com](mailto:salesaddresses@nexperia.com) (email)

Replace the copyright notice at the bottom of each page or elsewhere in the document, depending on the version, as shown below:

- © NXP N.V. (year). All rights reserved or © Koninklijke Philips Electronics N.V. (year). All rights reserved

Should be replaced with:

- © **Nexperia B.V. (year). All rights reserved.**

If you have any questions related to the data sheet, please contact our nearest sales office via e-mail or telephone (details via [salesaddresses@nexperia.com](mailto:salesaddresses@nexperia.com)). Thank you for your cooperation and understanding,

Kind regards,

Team Nexperia

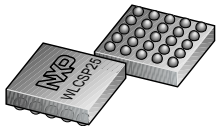

# IP4856CX25/C

SD 3.0-compliant memory card integrated dual voltage level translator with EMI filter and ESD protection

Rev. 2 — 15 October 2014

Product data sheet

## 1. General description

The device is an SD 3.0-compliant 6-bit bidirectional dual voltage level translator. It is designed to interface between a memory card operating at 1.8 V or 2.9 V signal levels and a host with a fixed nominal supply voltage of 1.7 V to 3.6 V. The device supports SD 3.0, SDR104, SDR50, DDR50, SDR25, SDR12 and SD 2.0 high-speed (50 MHz) and default-speed (25 MHz) modes. The device has an integrated voltage selectable low dropout regulator to supply the card-side I/Os, built-in EMI filters and robust ESD protections (IEC 61000-4-2, level 4).

## 2. Features and benefits

- Supports up to 208 MHz clock rate
- Feedback channel for clock synchronization
- SD 3.0 specification-compliant voltage translation to support SDR104, SDR50, DDR50, SDR25, SDR12, high-speed and default-speed modes
- 100 mA low dropout voltage regulator to supply the card-side I/Os
- Low power consumption by push-pull output stage with break-before-make architecture
- Integrated pull-up and pull-down resistors: no external resistors required
- Integrated EMI filters suppress higher harmonics of digital I/Os
- Integrated 8 kV ESD protection according to IEC 61000-4-2, level 4 on card side
- Level shifting buffers keep ESD stress away from the host (zero-clamping concept)
- 25-ball WLCSP; pitch 0.4 mm

## 3. Applications

- Smartphones
- Mobile handsets
- Digital cameras
- Tablet PCs
- Laptop computers
- SD, MMC or microSD card readers

## 4. Ordering information

Table 1. Ordering information

Type number	Package		
	Name	Description	Version
IP4856CX25/C	WLCSP25	wafer level chip-size package with back side coating; 25 bumps (5 × 5); typical size: 2.05 mm × 2.05 mm × 0.51 mm	-



5. Block diagram

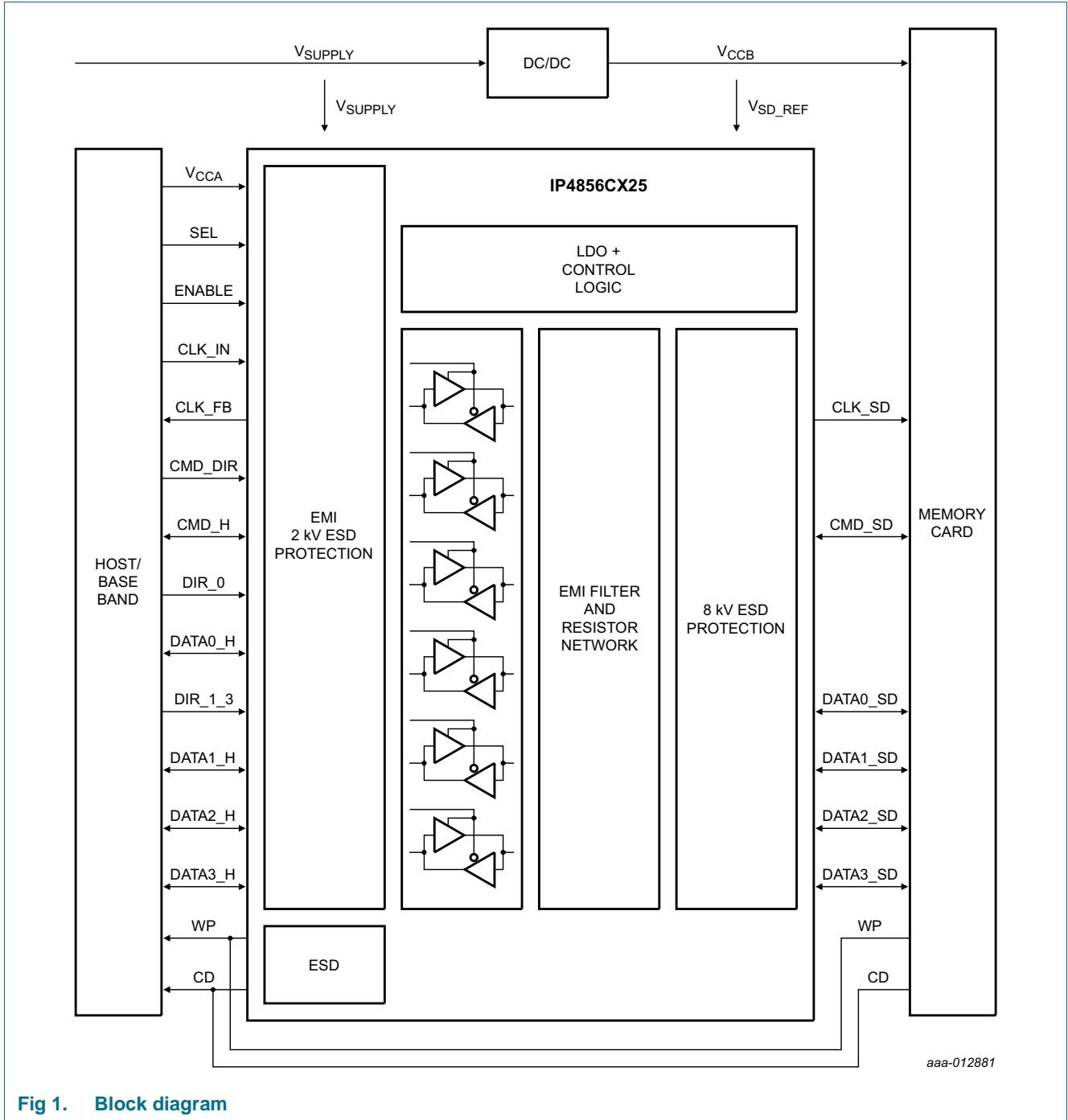

Fig 1. Block diagram

## 6. Functional diagram

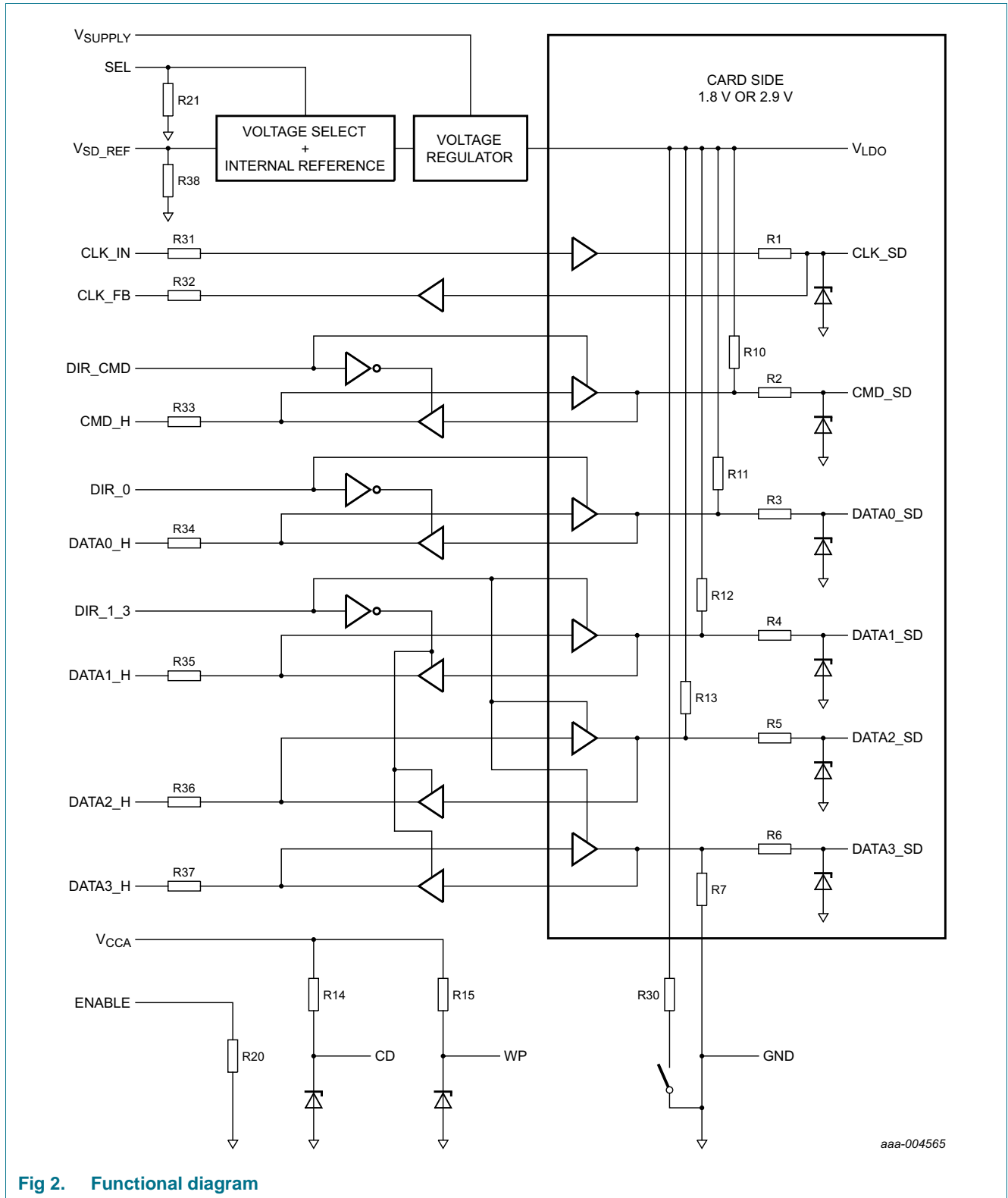

Fig 2. Functional diagram

## 7. Pinning information

### 7.1 Pinning

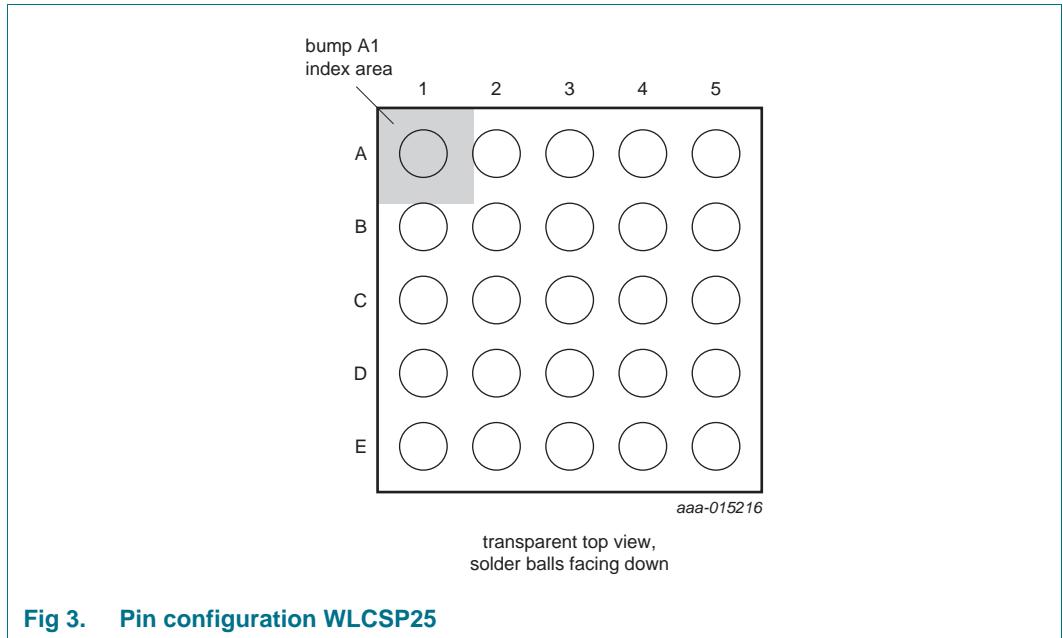

Fig 3. Pin configuration WLCSP25

Table 2. Pin allocation table

Pin	Symbol	Pin	Symbol	Pin	Symbol	Pin	Symbol	Pin	Symbol
A1	DATA2_H	A2	DIR_CMD	A3	DIR_0	A4	V <sub>SUPPLY</sub>	A5	DATA2_SD
B1	DATA3_H	B2	SEL	B3	V <sub>CCA</sub>	B4	V <sub>LDO</sub>	B5	DATA3_SD
C1	CLK_IN	C2	ENABLE	C3	GND	C4	V <sub>SD_REF</sub>	C5	CLK_SD
D1	DATA0_H	D2	CMD_H	D3	CD	D4	CMD_SD	D5	DATA0_SD
E1	DATA1_H	E2	CLK_FB	E3	DIR_1_3	E4	WP	E5	DATA1_SD

### 7.2 Pin description

Table 3. Pin description

Symbol <sup>[1]</sup>	Pin	Type <sup>[2]</sup>	Description
DATA2_H	A1	I/O	data 2 input or output on host side
DIR_CMD	A2	I	direction control input for command
DIR_0	A3	I	direction control input for data 0
V <sub>SUPPLY</sub>	A4	S	supply voltage (from battery or regulator)
DATA2_SD	A5	I/O	data 2 input or output on memory card side
DATA3_H	B1	I/O	data 3 input or output on host side
SEL	B2	I	card side I/O voltage level select
V <sub>CCA</sub>	B3	S	supply voltage from host side
V <sub>LDO</sub>	B4	O	internal supply decoupling
DATA3_SD	B5	I/O	data 3 input or output on memory card side

Table 3. Pin description ...continued

Symbol <sup>[1]</sup>	Pin	Type <sup>[2]</sup>	Description
CLK_IN	C1	I	clock signal input on host side
ENABLE	C2	I	device enable input
GND	C3	S	supply ground
V <sub>SD_REF</sub>	C4	I	reference voltage for the internal voltage regulator
CLK_SD	C5	O	clock signal output on memory card side
DATA0_H	D1	I/O	data 0 input or output on host side
CMD_H	D2	I/O	command input or output on host side
CD	D3	O	card detect switch biasing output
CMD_SD	D4	I/O	command input or output on memory card side
DATA0_SD	D5	I/O	data 0 input or output on memory card side
DATA1_H	E1	I/O	data 1 input or output on host side
CLK_FB	E2	O	clock feedback output on host side
DIR_1_3	E3	I	direction control input for data 1, data 2, data 3
WP	E4	O	write protect switch biasing output
DATA1_SD	E5	I/O	data 1 input or output on memory card side

[1] The pin names relate particularly to SD memory cards, but also apply to microSD and MMC memory cards.

[2] I = input, O = output, I/O = input and output, S = power supply.

## 8. Functional description

### 8.1 Level translator

The bidirectional level translator shifts the data between the I/O supply levels of the host and the memory card. Dedicated direction control signals determine if a command and data signals are transferred from the memory card to the host (card read mode) or from the host to the memory card (card write mode). The voltage translator has to support several clock and data transfer rates at the signaling levels specified in the SD 3.0 standard specification.

Table 4. Supported modes

Bus speed mode	Signal level (V)	Clock rate (MHz)	Data rate (MB/s)
Default-speed	3.3	25	12.5
High-speed	3.3	50	25
SDR12	1.8	25	12.5
SDR25	1.8	50	25
SDR50	1.8	100	50
SDR104	1.8	208	104
DDR50	1.8	50	50

## 8.2 Enable and direction control

The pin ENABLE enables/disables the internal Low DropOut (LDO) regulator and is used to put the host-side and card-side I/O drivers into high-ohmic (3-state) mode.

Table 5. I/O function control signal truth table

Control		Host side		Memory card side	
Pin	Level <sup>[1]</sup>	Pin	Function	Pin	Function
<b>Pin ENABLE = HIGH and <math>V_{CCA} \geq 1.62</math> V</b>					
DIR_CMD	H	CMD_H	input	CMD_SD	output
	L	CMD_H	output	CMD_SD	input
DIR_0	H	DATA0_H	input	DATA0_SD	output
	L	DATA0_H	output	DATA0_SD	input
DIR_1_3	H	DATA1_H DATA2_H DATA3_H	input	DATA1_SD DATA2_SD DATA3_SD	output
	L	DATA1_H DATA2_H DATA3_H	output	DATA1_SD DATA2_SD DATA3_SD	input
-	-	CLK_IN	input	CLK_SD	output
-	-	CLK_FB	output	-	-
<b>Pin ENABLE = LOW or <math>V_{CCA} \leq 0.8</math> V</b>					
DIR_CMD	X	CMD_H	high-ohmic	CMD_SD	high-ohmic
DIR_0	X	DATA0_H	high-ohmic	DATA0_SD	high-ohmic
DIR_1_3	X	DATA1_H DATA2_H DATA3_H	high-ohmic	DATA1_SD DATA2_SD DATA3_SD	high-ohmic
-	-	CLK_IN	input	CLK_SD	high-ohmic
-	-	CLK_IN	high-ohmic	-	-

[1] H = HIGH; L = LOW; X = don't care.

## 8.3 Integrated voltage regulator

The low dropout voltage regulator delivers supply voltage for the voltage translators and the card-side input/output stages. It has to support 1.8 V and 3 V signaling modes as stipulated in the SD 3.0 specification. The switching time between the two output voltage modes is compliant with SD 3.0 specification. Depending on the signaling level at pin SEL, the regulator delivers 1.8 V (SEL = HIGH) or 2.9 V (SEL = LOW,  $V_{SD\_REF} < 1$  V). For card supply voltage, see [Section 8.4](#).

Table 6. SD card side voltage level control signal truth table

Input		Output		
SEL <sup>[1]</sup>	$V_{SD\_REF}$ <sup>[1]</sup>	$V_{LDO}$	Pin <sup>[2]</sup>	Function
H	X	1.8 V	DATA0_SD to DATA3_SD, CLK_SD	low supply voltage level (1.8 V typical)
L	< 1 V	2.9 V	DATA0_SD to DATA3_SD, CLK_SD	high supply voltage level (2.9 V typical)
	> 1.5 V	$V_{SD\_REF}$	DATA0_SD to DATA3_SD, CLK_SD	supply voltage level based on $V_{SD\_REF}$

[1] H = HIGH; L = LOW; X = don't care.

[2] Host-side pins are not influenced by SEL.

An external capacitor is needed between the regulator output pin  $V_{LDO}$  and ground for proper operation of the integrated voltage regulator. See [Table 8](#) for recommended capacitance and equivalent series resistance. To place the capacitor close to the  $V_{LDO}$  pin and maintain short connections to both, to the  $V_{LDO}$  and to the ground, is recommended.

#### 8.4 Memory card voltage tracking (reference select)

The device can track the memory card supply via pin  $V_{SD\_REF}$ . This allows achieving optimum interoperability by perfectly matching input/output levels between voltage translator and memory card in the 3 V signaling mode. Therefore, the voltage regulator aims to follow the reference voltage provided at input  $V_{SD\_REF}$  directly. If tracking of the memory card supply is not desired, connect pin  $V_{SD\_REF}$  to ground so the voltage regulator refers to an integrated voltage reference. For 1.8 V (SEL = HIGH) signaling, the voltage regulator is referred to the internal reference which is independent of the voltage at  $V_{SD\_REF}$ .

#### 8.5 Feedback clock channel

The clock is transmitted from the host to the memory card side. The voltage translator and the Printed-Circuit Board (PCB) tracks introduce some amount of delay. It reduces timing margin for data read back from memory card, especially at higher data rates. Therefore, a feedback path is provided to compensate the delay. The reasoning behind this approach is the fact that the clock is always delivered by the host, while the data in the timing critical read mode comes from the card.

#### 8.6 EMI filter

All input/output driver stages are equipped with EMI filters to reduce interferences towards sensitive mobile communication.

#### 8.7 ESD protection

The device has robust ESD protections on all memory card pins as well as on the  $V_{SD\_REF}$  and  $V_{SUPPLY}$  pins. The architecture prevents any stress for the host: the voltage translator discharges any stress to supply ground.

Pins Write Protect (WP) and Card Detection (CD) might be pulled down by the memory card which has to be detected by the host. Both signals must be HIGH if no card is inserted. Therefore the pins are equipped with International Electrotechnical Commission (IEC) system-level ESD protections and pull-up resistors connected to the host supply  $V_{CCA}$ .



## 9. Limiting values

**Table 7. Limiting values**

In accordance with the Absolute Maximum Rating System (IEC 60134).

Symbol	Parameter	Conditions	Min	Max	Unit
V <sub>CC</sub>	supply voltage	4 ms transient			
		on pin V <sub>SUPPLY</sub>	-0.5	+4.6	V
		on pin V <sub>CCA</sub>	-0.5	+4.6	V
V <sub>I</sub>	input voltage	4 ms transient at I/O pins	-0.5	+4.6	V
P <sub>tot</sub>	total power dissipation	T <sub>amb</sub> = -40 °C to +85 °C	-	1000	mW
T <sub>stg</sub>	storage temperature		-55	+150	°C
T <sub>amb</sub>	ambient temperature		-40	+85	°C
V <sub>ESD</sub>	electrostatic discharge voltage	IEC 61000-4-2, level 4, all memory card-side pins, V <sub>SUPPLY</sub> , V <sub>SD_REF</sub> , WP and CD to ground <a href="#">[1]</a>			
		contact discharge	-8	+8	kV
		air discharge	-15	+15	kV
		Human Body Model (HBM) JEDEC JESD22-A114F; all pins	-2000	+2000	V
		Machine Model (MM) JEDEC JESD22-A115; all pins	-200	+200	V
I <sub>lu(IO)</sub>	input/output latch-up current	JESD78B: -0.5 × V <sub>CC</sub> < V <sub>I</sub> < 1.5 × V <sub>CC</sub> ; T <sub>j</sub> < 125 °C	-100	+100	mA

[1] All system level tests are performed with the application-specific capacitors connected to the supply pins V<sub>SUPPLY</sub>, V<sub>LDO</sub> and V<sub>CCA</sub>.

## 10. Recommended operating conditions

**Table 8. Operating conditions**

Symbol	Parameter	Conditions	Min	Typ	Max	Unit
V <sub>CC</sub>	supply voltage	on pin V <sub>SUPPLY</sub> <a href="#">[1]</a>	2.8	-	3.6	V
		on pin V <sub>CCA</sub>	1.7	-	V <sub>SUPPLY</sub>	V
V <sub>I</sub>	input voltage	host side <a href="#">[2]</a>	-0.3	-	V <sub>CCA</sub> + 0.3	V
		memory card side	-0.3	-	V <sub>O(reg)</sub> + 0.3	V
C <sub>ext</sub>	external capacitance	recommended capacitor at pin V <sub>LDO</sub>	-	1.0	-	μF
ESR	equivalent series resistance	at pin V <sub>LDO</sub>	0	-	50	mΩ
C <sub>ext</sub>	external capacitance	recommended capacitor at pin V <sub>SUPPLY</sub>	-	0.1	-	μF
		recommended capacitor at pin V <sub>CCA</sub>	-	0.1	-	μF

[1] By minimum value the device is still fully functional, but the voltage on pin V<sub>LDO</sub> might drop below the recommended memory card supply voltage.

[2] The voltage must not exceed 3.6 V.

**Table 9. Integrated resistors** $T_{amb} = 25\text{ }^{\circ}\text{C}$ ; unless otherwise specified.

Symbol	Parameter	Conditions	Min	Typ	Max	Unit	
$R_{pd}$	pull-down resistance	R7	272	470	668	$k\Omega$	
		R30	70	100	130	$\Omega$	
		R20; R21; R38	200	350	500	$k\Omega$	
$R_{pu}$	pull-up resistance	R10	10.5	15	19.5	$k\Omega$	
		R11 to R13	49	70	91	$k\Omega$	
		R14 and R15	70	100	130	$k\Omega$	
$R_s$	series resistance	card side; R1 to R6	[1]	12	15	18	$\Omega$
		host side; R31 to R37	[1]	18	22.5	27	$\Omega$

[1] Guaranteed by design and characterization.

## 11. Static characteristics

**Table 10. Static characteristics**At recommended operating conditions;  $T_{amb} = -40\text{ }^{\circ}\text{C}$  to  $+85\text{ }^{\circ}\text{C}$ ; voltages are referenced to GND (ground = 0 V);  $C_{ext} = 1\text{ }\mu\text{F}$  at pin  $V_{LDO}$ ; unless otherwise specified.

Symbol	Parameter	Conditions	Min	Typ <sup>[1]</sup>	Max	Unit
<b>Supply voltage regulator for card-side I/O pin: <math>V_{LDO}</math></b>						
$V_{O(reg)}$	regulator output voltage	SEL = LOW; $V_{SD\_REF} < 1\text{ V}$ ; $V_{SUPPLY} \geq 2.9\text{ V}$	2.7	2.9	3.3	V
		SEL = LOW; $V_{SD\_REF} > 1.5\text{ V}$ ; $V_{SUPPLY} \geq V_{SD\_REF}$	$V_{SD\_REF} - 0.15$	$V_{SD\_REF}$	$V_{SD\_REF} + 0.15$	V
		SEL = HIGH; $V_{SUPPLY} \geq 2.5\text{ V}$	1.7	1.85	2.0	V
$V_{do(reg)}$	regulator dropout voltage	SEL = LOW; $V_{SUPPLY} \leq 2.9\text{ V}$ ; $I_O = 50\text{ mA}$	-	-	150	mV
$I_{O(reg)}$	regulator output current		-	-	100	mA
<b>Host-side input signals: CMD_H, DATA0_H to DATA3_H and CLK_IN</b>						
$V_{IH}$	HIGH-level input voltage		$0.625 \times V_{CCA}$	-	$V_{CCA} + 0.3$	V
$V_{IL}$	LOW-level input voltage		-0.3	-	$0.35 \times V_{CCA}$	V
$I_{LI}$	input leakage current	$V_{CCA} = 1.8\text{ V}$ ; ENABLE = LOW	[2]	-	1.0	nA
<b>Host-side control signals</b>						
SEL, ENABLE, DIR_0, DIR_1_3 and DIR_CMD						
$V_{IH}$	HIGH-level input voltage		$0.625 \times V_{CCA}$	-	$V_{CCA} + 0.3$	V
$V_{IL}$	LOW-level input voltage		-0.3	-	$0.35 \times V_{CCA}$	V
$V_{SD\_REF}$						
$V_{IH}$	HIGH-level input voltage		1.5	-	3.63	V
$V_{IL}$	LOW-level input voltage		-0.3	-	+1.0	V

## SD 3.0-compliant memory card integrated dual voltage level translator

**Table 10. Static characteristics ...continued**

At recommended operating conditions;  $T_{amb} = -40\text{ }^{\circ}\text{C}$  to  $+85\text{ }^{\circ}\text{C}$ ; voltages are referenced to GND (ground = 0 V);  $C_{ext} = 1\text{ }\mu\text{F}$  at pin  $V_{LDO}$ ; unless otherwise specified.

Symbol	Parameter	Conditions	Min	Typ <sup>[1]</sup>	Max	Unit
<b>Host-side output signals: CLK_FB, CMD_H and DATA0_H to DATA3_H</b>						
$V_{OH}$	HIGH-level output voltage	$I_O = 2\text{ mA}$ ; $V_I = V_{IH}$ (card side)	$0.85 \times V_{CCA}$	-	-	V
$V_{OL}$	LOW-level output voltage	$I_O = -2\text{ mA}$ ; $V_I = V_{IL}$ (card side)	-	-	$0.125 \times V_{CCA}$	V
<b>Card-side input signals: CMD_SD and DATA0_SD to DATA3_SD</b>						
$V_{IH}$	HIGH-level input voltage	SEL = LOW (2.9 V interface)	$0.625 \times V_{O(reg)}$	-	$V_{O(reg)} + 0.3$	V
		SEL = HIGH (1.8 V interface)	$0.625 \times V_{O(reg)}$	-	$V_{O(reg)} + 0.3$	V
$V_{IL}$	LOW-level input voltage	SEL = LOW (2.9 V interface)	-0.3	-	$0.35 \times V_{O(reg)}$	V
		SEL = HIGH (1.8 V interface)	-0.3	-	$0.35 \times V_{O(reg)}$	V
<b>Card-side output signal</b>						
<b>CMD_SD, DATA0_SD to DATA3_SD and CLK_SD</b>						
$V_{OH}$	HIGH-level output voltage	$I_O = 4\text{ mA}$ ; $V_I = V_{IH}$ (host side); SEL = LOW (2.9 V interface)	$0.85 \times V_{O(reg)}$	-	$V_{O(reg)} + 0.3$	V
		$I_O = 2\text{ mA}$ ; $V_I = V_{IH}$ (host side); SEL = HIGH (1.8 V interface)	$0.85 \times V_{O(reg)}$	-	2.0	V
$V_{OL}$	LOW-level output voltage	$I_O = -4\text{ mA}$ ; $V_I = V_{IL}$ (host side); SEL = LOW (2.9 V interface)	-0.3	-	$0.125 \times V_{O(reg)}$	V
		$I_O = -2\text{ mA}$ ; $V_I = V_{IL}$ (host side); SEL = HIGH (1.8 V interface)	-0.3	-	$0.125 \times V_{O(reg)}$	V
<b>Bus signal equivalent capacitance</b>						
$C_{ch}$	channel capacitance	$V_I = 0\text{ V}$ ; $f_i = 1\text{ MHz}$ ; $V_{SUPPLY} = 3.5\text{ V}$ ; $V_{CCA} = 1.8\text{ V}$ <sup>[3]</sup>				
		host side	-	3.5	5.0	pF
		card side	-	5.0	10.0	pF
<b>Current consumption</b>						
$I_{CC(stat)}$	static supply current	ENABLE = HIGH (active mode); all inputs = HIGH; DIR = LOW				
		SEL = LOW (2.9 V interface)	-	-	100	$\mu\text{A}$
		SEL = HIGH (1.8 V interface)	-	-	100	$\mu\text{A}$
$I_{CC(stb)}$	standby supply current	ENABLE = LOW (inactive mode)	-	-	1	$\mu\text{A}$

[1] Typical values are measured at  $T_{amb} = 25\text{ }^{\circ}\text{C}$ .

[2] Guaranteed by design and characterization.

[3] EMI filter line capacitance per data channel from I/O driver to pin;  $C_{ch}$  is guaranteed by design.

## 12. Dynamic characteristics

### 12.1 Voltage regulator

**Table 11. Voltage regulator**

$T_{amb} = 25\text{ }^{\circ}\text{C}$ ; unless otherwise specified.

Symbol	Parameter	Conditions	Min	Typ	Max	Unit
<b>Voltage regulator output pin: <math>V_{LDO}</math></b>						
$t_{startup(reg)}$	regulator start-up time	$V_{CCA} = 1.8\text{ V}$ ; $V_{SUPPLY} = 3.5\text{ V}$ ; $C_{ext} = 1\text{ }\mu\text{F}$ ; see <a href="#">Figure 5</a>	-	-	100	$\mu\text{s}$
$t_{f(o)}$	output fall time	$V_{O(reg)} = 2.9\text{ V}$ to $1.8\text{ V}$ ; SEL = LOW to HIGH; see <a href="#">Figure 4</a>	-	-	1	ms
$t_{r(o)}$	output rise time	$V_{O(reg)} = 1.8\text{ V}$ to $2.9\text{ V}$ ; SEL = HIGH to LOW; see <a href="#">Figure 4</a>	-	-	100	$\mu\text{s}$

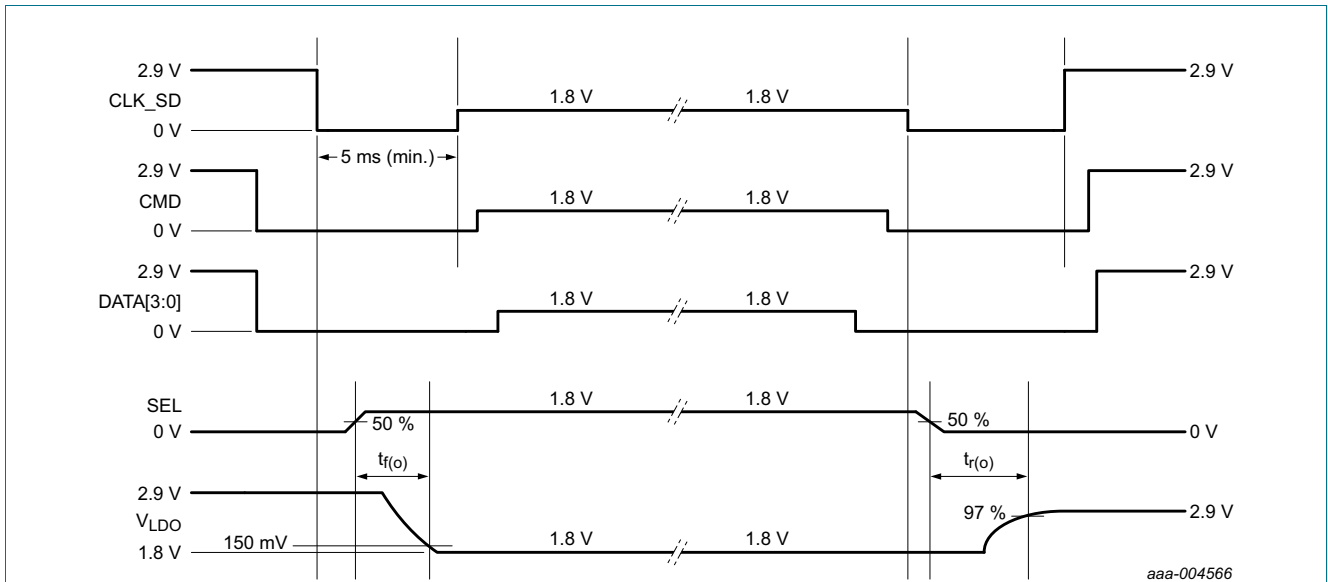

**Fig 4. Regulator mode change timing**

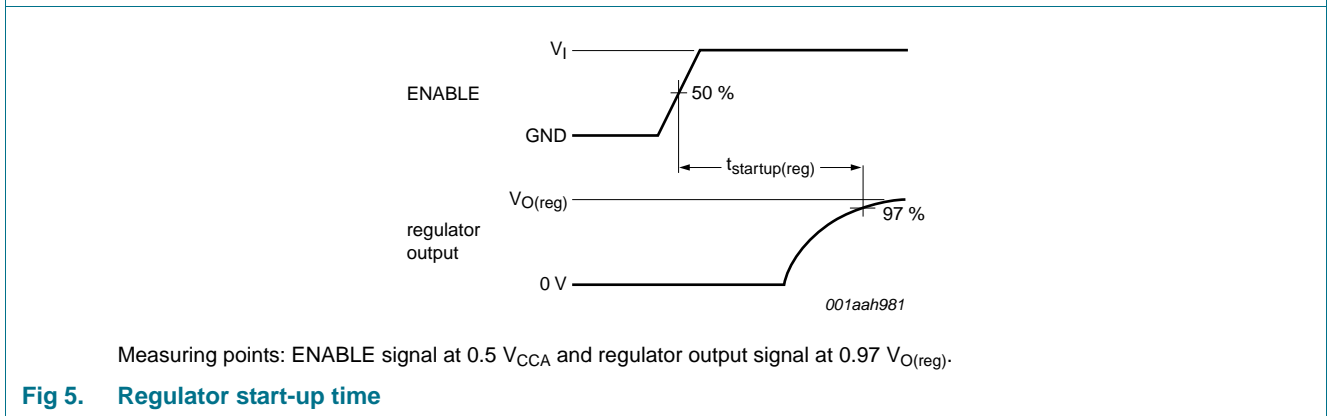

**Fig 5. Regulator start-up time**

12.2 Level translator

Table 12. Level translator dynamic characteristics

At recommended operating conditions;  $V_{CCA} = 1.8\text{ V}$ ;  $T_{amb} = 25\text{ }^{\circ}\text{C}$ ; unless otherwise specified.

Symbol	Parameter	Conditions	Min	Typ	Max	Unit
<b>Host-side transition times</b>						
$t_r$	rise time	SEL = HIGH (1.8 V interface) [1]	-	0.4	1.0	ns
$t_f$	fall time	SEL = HIGH (1.8 V interface) [1]	-	0.4	1.0	ns
<b>Card-side transition times</b>						
$t_r$	rise time	SEL = HIGH (1.8 V interface) [2]	0.4	0.9	1.4	ns
$t_f$	fall time	SEL = HIGH (1.8 V interface) [2]	0.4	0.9	1.4	ns
<b>Host-side to card-side propagation delay</b>						
DATAx_H to DATAx_SD, CMD_H to CMD_SD and CLK_IN to CLK_SD						
$t_{pd}$	propagation delay	SEL = HIGH (1.8 V interface)	-	2.4	3.5	ns
<b>Host-side to host-side propagation delay</b>						
CLK_IN to CLK_FB						
$t_{pd}$	propagation delay	SEL = HIGH (1.8 V interface)	-	4.8	7.0	ns
<b>Card-side to host-side propagation delay</b>						
DATAx_SD to DATAx_H and CMD_SD to CMD_H						
$t_{pd}$	propagation delay	SEL = HIGH (1.8 V interface)	-	2.4	3.5	ns

[1] Transition between  $V_{OL} = 0.35 \times V_{CCA}$  and  $V_{OH} = 0.65 \times V_{CCA}$ .

[2] Transition between  $V_{OL} = 0.45\text{ V}$  and  $V_{OH} = 1.4\text{ V}$ .

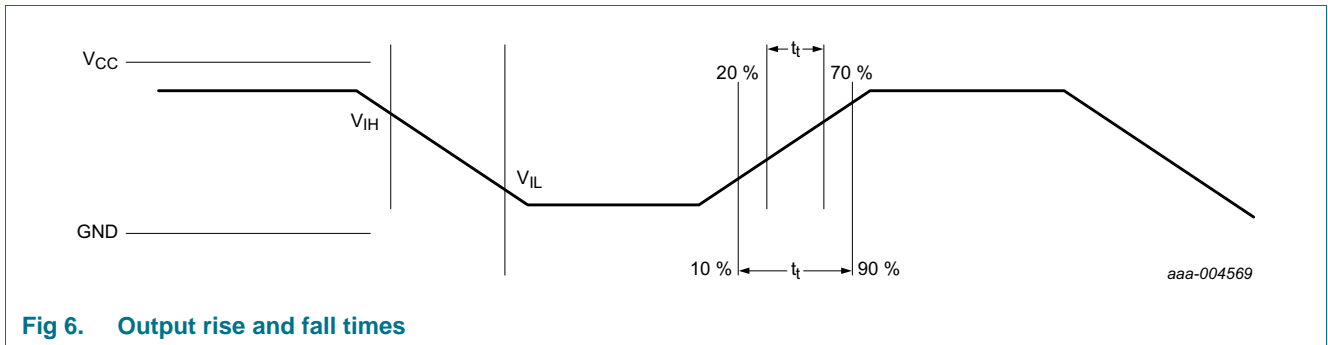

Fig 6. Output rise and fall times

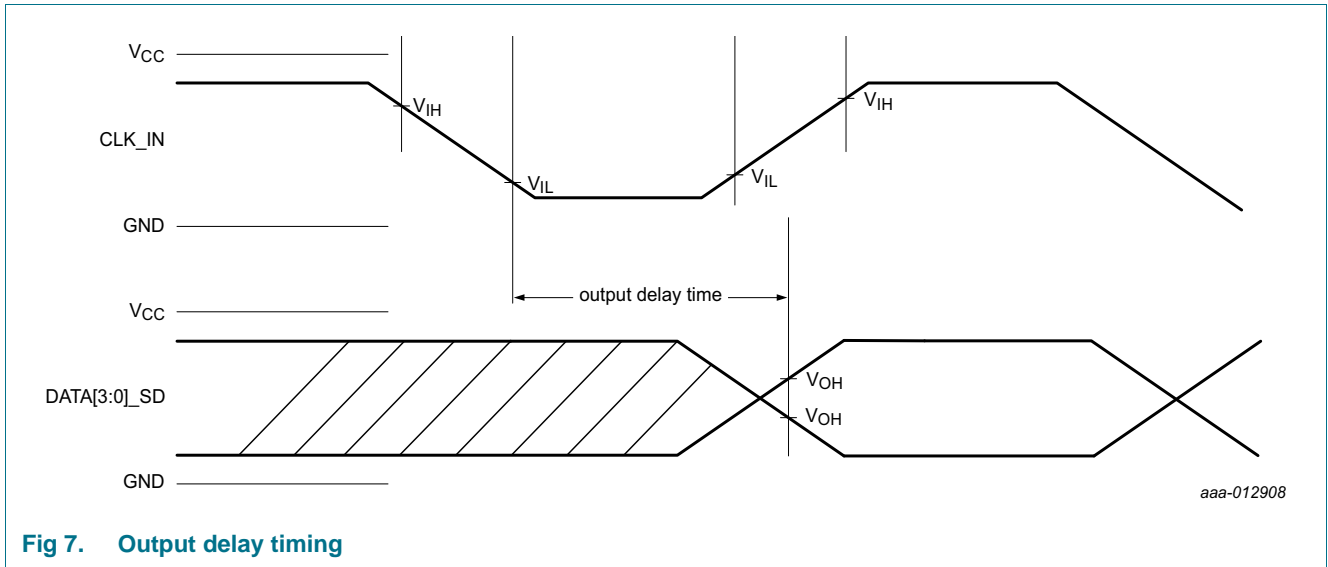

Fig 7. Output delay timing

### 12.3 ESD characteristic of pin write protect and card detect

Table 13. ESD characteristic of write protect and card detect

At recommended operating conditions;  $T_{amb} = 25\text{ }^{\circ}\text{C}$ ; voltages are referenced to GND (ground = 0 V); unless otherwise specified.

Symbol	Parameter	Conditions	Min	Typ	Max	Unit
<b>ESD protection pins: WP and CD</b>						
$V_{BR}$	breakdown voltage	TLP; $I = 1\text{ mA}$	-	8	-	V
$r_{dyn}$	dynamic resistance	positive transient	[1]	0.5	-	$\Omega$
		negative transient	[1]	0.5	-	$\Omega$

[1] TLP according to ANSI-ESD STM5.5.1/IEC 62615  $Z_0 = 50\ \Omega$ ; pulse width = 100 ns; rise time = 200 ps; averaging window = 50 ns to 80 ns.

13. Test information

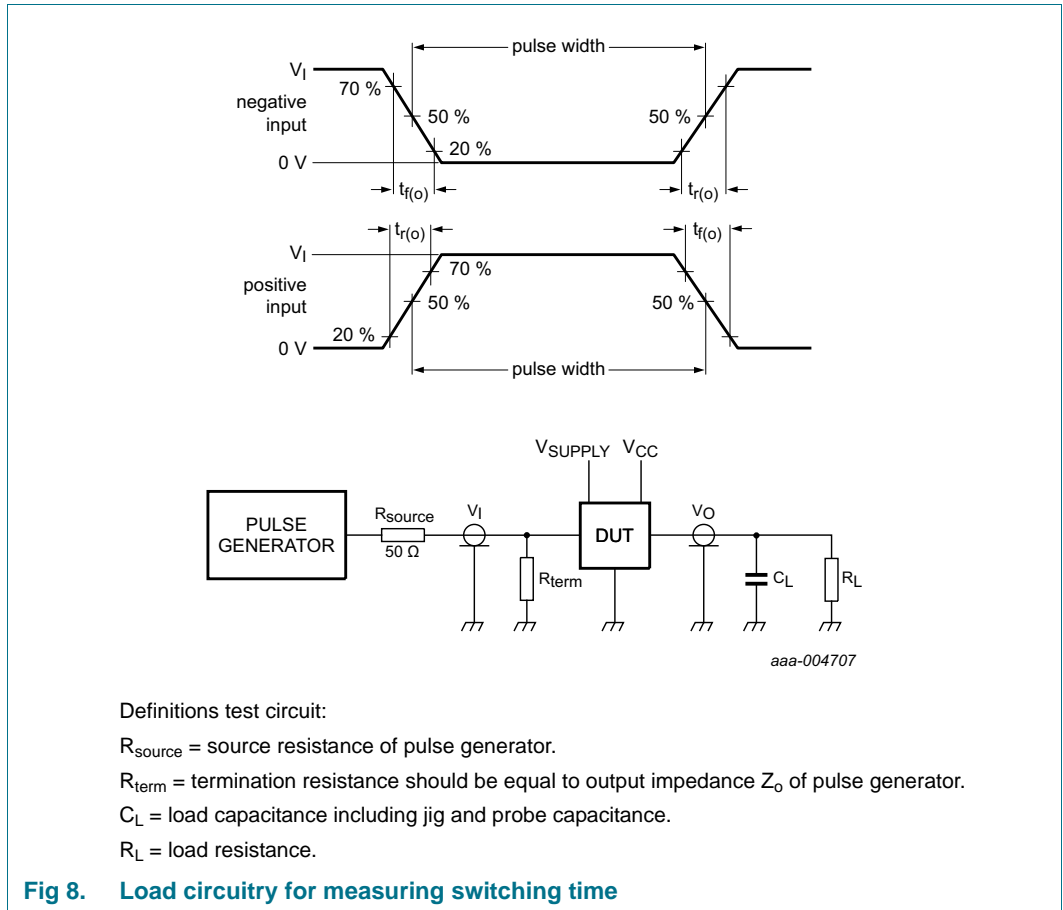

14. Package outline

WLCSP25: wafer level chip-size package with back side coating; 25 bumps (5 x 5)

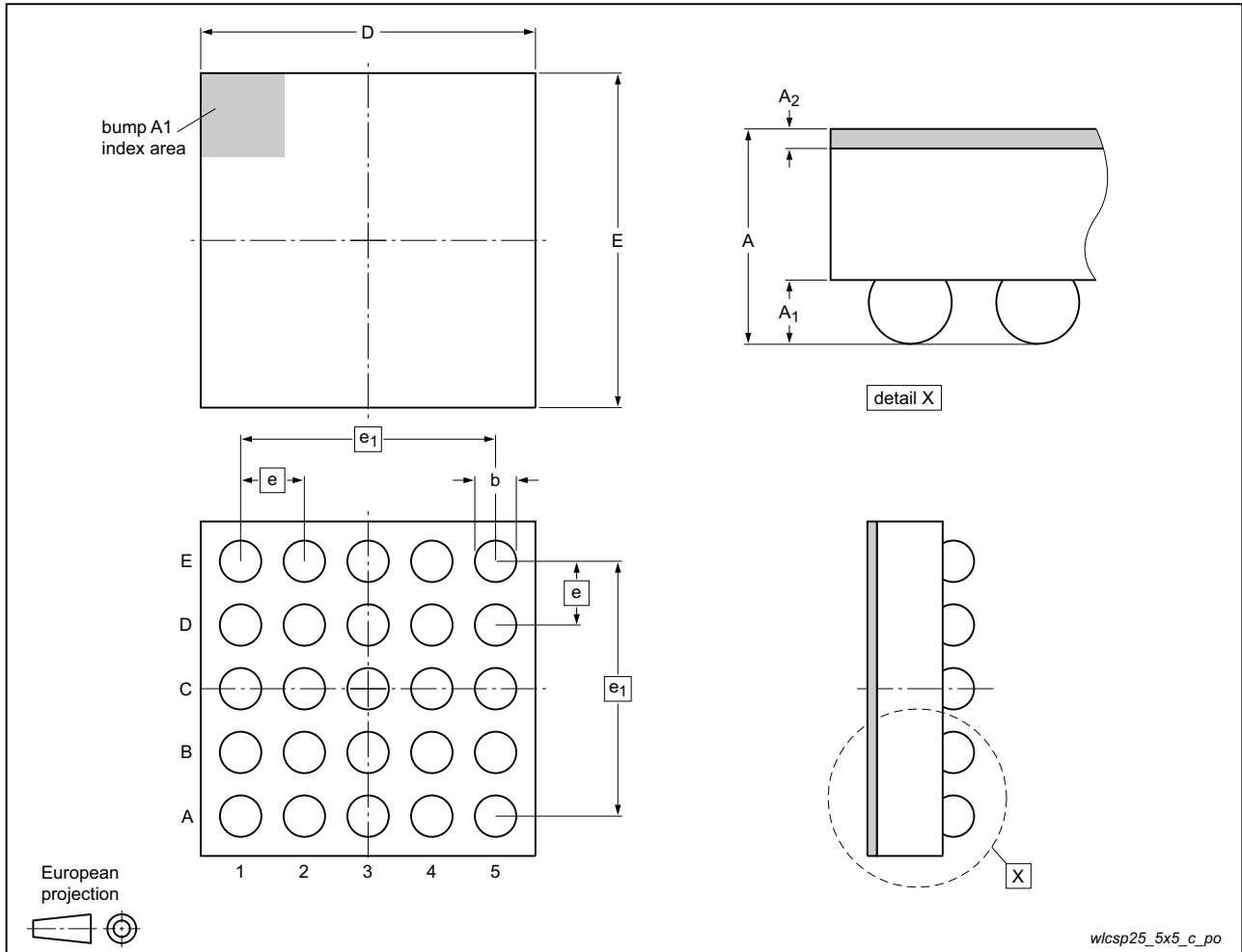

Fig 9. Package outline IP4856CX25/C (WLCSP25 with back side coating)

Table 14. Dimensions for Figure 9

Symbol	Min	Typ	Max	Unit
A	0.47	0.51	0.55	mm
A <sub>1</sub>	0.18	0.20	0.22	mm
A <sub>2</sub>	0.03	0.04	0.05	mm
b	0.23	0.25	0.27	mm
D	2.01	2.05	2.09	mm
E	2.01	2.05	2.09	mm
e	-	0.4	-	mm
e <sub>1</sub>	-	1.6	-	mm



## 15. Design and assembly recommendations

### 15.1 PCB design guidelines

For optimum performance, use a Non-Solder Mask PCB Design (NSMD), also known as a copper-defined design, incorporating laser-drilled micro-vias connecting the ground pads to a buried ground-plane layer. This results in the lowest possible ground inductance and provides the best high frequency and ESD performance. For this case, refer to [Table 15](#) for the recommended PCB design parameters.

**Table 15. Recommended PCB design parameters**

Parameter	Value or specification
PCB pad diameter	250 $\mu\text{m}$
Micro-via diameter	100 $\mu\text{m}$ (0.004 inch)
Solder mask aperture diameter	325 $\mu\text{m}$
Copper thickness	20 $\mu\text{m}$ to 40 $\mu\text{m}$
Copper finish	AuNi or OSP
PCB material	FR4

### 15.2 PCB assembly guidelines for Pb-free soldering

**Table 16. Assembly recommendations**

Parameter	Value or specification
Solder screen aperture diameter	290 $\mu\text{m}$
Solder screen thickness	100 $\mu\text{m}$ (0.004 inch)
Solder paste: Pb-free	SnAg (3 % to 4 %) Cu (0.5 % to 0.9 %)
Solder to flux ratio	50 : 50
Solder reflow profile	see <a href="#">Figure 10</a>

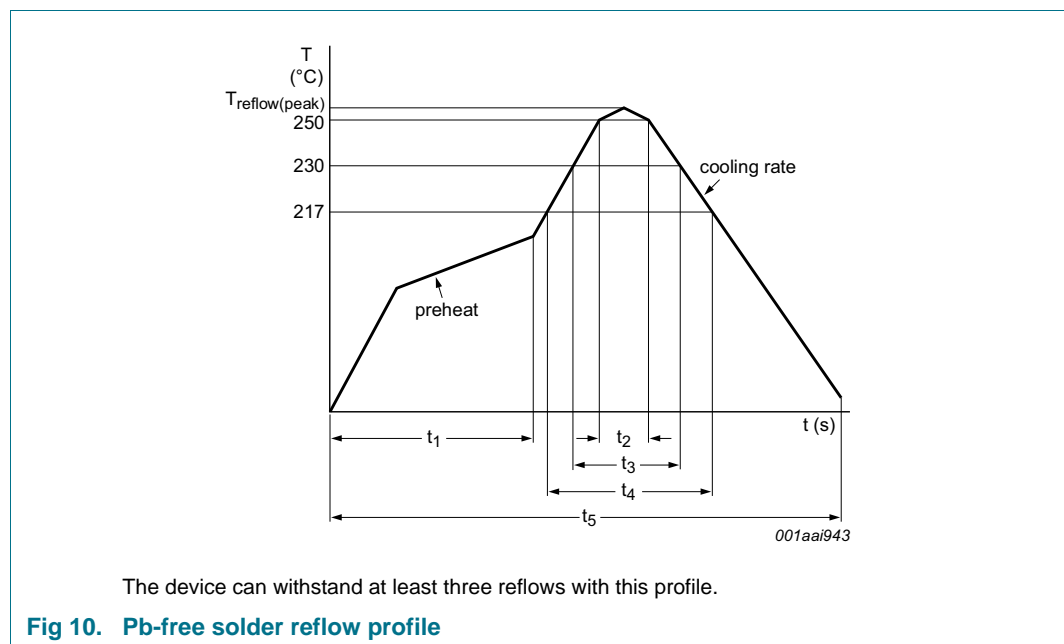

Table 17. Reflow soldering process characteristics

Symbol	Parameter	Conditions	Min	Typ	Max	Unit
$T_{\text{reflow(peak)}}$	peak reflow temperature		230	-	260	°C
$t_1$	time 1	soak time	60	-	180	s
$t_2$	time 2	time during $T \geq 250$ °C	-	-	30	s
$t_3$	time 3	time during $T \geq 230$ °C	10	-	50	s
$t_4$	time 4	time during $T > 217$ °C	30	-	150	s
$t_5$	time 5		-	-	540	s
$dT/dt$	rate of change of temperature	cooling rate	-	-	-6	°C/s
		preheat	2.5	-	4.0	°C/s

## 16. Abbreviations

Table 18. Abbreviations

Acronym	Description
DUT	Device Under Test
EMI	ElectroMagnetic Interference
ESD	ElectroStatic Discharge
FR4	Flame Retard 4
MMC	MultiMedia Card
NSMD	Non-Solder Mask PCB Design
OSP	Organic Solderability Preservation
PCB	Printed-Circuit Board
RoHS	Restriction of Hazardous Substances
SD	Secure Digital
WLCSP	Wafer-Level Chip-Scale Package

## 17. Revision history

Table 19. Revision history

Document ID	Release date	Data sheet status	Change notice	Supersedes
IP4856CX25_C v.2	20141015	Product data sheet	-	IP4856CX25 v.1
Modifications:	<ul style="list-style-type: none"><li>• Product without back side coating has been removed</li><li>• Product status changed</li></ul>			
IP4856CX25 v.1	20140602	Preliminary data sheet	-	-

## 18. Legal information

### 18.1 Data sheet status

Document status <sup>[1][2]</sup>	Product status <sup>[3]</sup>	Definition
Objective [short] data sheet	Development	This document contains data from the objective specification for product development.
Preliminary [short] data sheet	Qualification	This document contains data from the preliminary specification.
Product [short] data sheet	Production	This document contains the product specification.

[1] Please consult the most recently issued document before initiating or completing a design.

[2] The term 'short data sheet' is explained in section "Definitions".

[3] The product status of device(s) described in this document may have changed since this document was published and may differ in case of multiple devices. The latest product status information is available on the Internet at URL <http://www.nxp.com>.

### 18.2 Definitions

**Draft** — The document is a draft version only. The content is still under internal review and subject to formal approval, which may result in modifications or additions. NXP Semiconductors does not give any representations or warranties as to the accuracy or completeness of information included herein and shall have no liability for the consequences of use of such information.

**Short data sheet** — A short data sheet is an extract from a full data sheet with the same product type number(s) and title. A short data sheet is intended for quick reference only and should not be relied upon to contain detailed and full information. For detailed and full information see the relevant full data sheet, which is available on request via the local NXP Semiconductors sales office. In case of any inconsistency or conflict with the short data sheet, the full data sheet shall prevail.

**Product specification** — The information and data provided in a Product data sheet shall define the specification of the product as agreed between NXP Semiconductors and its customer, unless NXP Semiconductors and customer have explicitly agreed otherwise in writing. In no event however, shall an agreement be valid in which the NXP Semiconductors product is deemed to offer functions and qualities beyond those described in the Product data sheet.

### 18.3 Disclaimers

**Limited warranty and liability** — Information in this document is believed to be accurate and reliable. However, NXP Semiconductors does not give any representations or warranties, expressed or implied, as to the accuracy or completeness of such information and shall have no liability for the consequences of use of such information. NXP Semiconductors takes no responsibility for the content in this document if provided by an information source outside of NXP Semiconductors.

In no event shall NXP Semiconductors be liable for any indirect, incidental, punitive, special or consequential damages (including - without limitation - lost profits, lost savings, business interruption, costs related to the removal or replacement of any products or rework charges) whether or not such damages are based on tort (including negligence), warranty, breach of contract or any other legal theory.

Notwithstanding any damages that customer might incur for any reason whatsoever, NXP Semiconductors' aggregate and cumulative liability towards customer for the products described herein shall be limited in accordance with the *Terms and conditions of commercial sale* of NXP Semiconductors.

**Right to make changes** — NXP Semiconductors reserves the right to make changes to information published in this document, including without limitation specifications and product descriptions, at any time and without notice. This document supersedes and replaces all information supplied prior to the publication hereof.

**Suitability for use** — NXP Semiconductors products are not designed, authorized or warranted to be suitable for use in life support, life-critical or safety-critical systems or equipment, nor in applications where failure or malfunction of an NXP Semiconductors product can reasonably be expected to result in personal injury, death or severe property or environmental damage. NXP Semiconductors and its suppliers accept no liability for inclusion and/or use of NXP Semiconductors products in such equipment or applications and therefore such inclusion and/or use is at the customer's own risk.

**Applications** — Applications that are described herein for any of these products are for illustrative purposes only. NXP Semiconductors makes no representation or warranty that such applications will be suitable for the specified use without further testing or modification.

Customers are responsible for the design and operation of their applications and products using NXP Semiconductors products, and NXP Semiconductors accepts no liability for any assistance with applications or customer product design. It is customer's sole responsibility to determine whether the NXP Semiconductors product is suitable and fit for the customer's applications and products planned, as well as for the planned application and use of customer's third party customer(s). Customers should provide appropriate design and operating safeguards to minimize the risks associated with their applications and products.

NXP Semiconductors does not accept any liability related to any default, damage, costs or problem which is based on any weakness or default in the customer's applications or products, or the application or use by customer's third party customer(s). Customer is responsible for doing all necessary testing for the customer's applications and products using NXP Semiconductors products in order to avoid a default of the applications and the products or of the application or use by customer's third party customer(s). NXP does not accept any liability in this respect.

**Limiting values** — Stress above one or more limiting values (as defined in the Absolute Maximum Ratings System of IEC 60134) will cause permanent damage to the device. Limiting values are stress ratings only and (proper) operation of the device at these or any other conditions above those given in the Recommended operating conditions section (if present) or the Characteristics sections of this document is not warranted. Constant or repeated exposure to limiting values will permanently and irreversibly affect the quality and reliability of the device.

**Terms and conditions of commercial sale** — NXP Semiconductors products are sold subject to the general terms and conditions of commercial sale, as published at <http://www.nxp.com/profile/terms>, unless otherwise agreed in a valid written individual agreement. In case an individual agreement is concluded only the terms and conditions of the respective agreement shall apply. NXP Semiconductors hereby expressly objects to applying the customer's general terms and conditions with regard to the purchase of NXP Semiconductors products by customer.

**No offer to sell or license** — Nothing in this document may be interpreted or construed as an offer to sell products that is open for acceptance or the grant, conveyance or implication of any license under any copyrights, patents or other industrial or intellectual property rights.

**Export control** — This document as well as the item(s) described herein may be subject to export control regulations. Export might require a prior authorization from competent authorities.

**Non-automotive qualified products** — Unless this data sheet expressly states that this specific NXP Semiconductors product is automotive qualified, the product is not suitable for automotive use. It is neither qualified nor tested in accordance with automotive testing or application requirements. NXP Semiconductors accepts no liability for inclusion and/or use of non-automotive qualified products in automotive equipment or applications.

In the event that customer uses the product for design-in and use in automotive applications to automotive specifications and standards, customer (a) shall use the product without NXP Semiconductors' warranty of the product for such automotive applications, use and specifications, and (b) whenever customer uses the product for automotive applications beyond

NXP Semiconductors' specifications such use shall be solely at customer's own risk, and (c) customer fully indemnifies NXP Semiconductors for any liability, damages or failed product claims resulting from customer design and use of the product for automotive applications beyond NXP Semiconductors' standard warranty and NXP Semiconductors' product specifications.

**Translations** — A non-English (translated) version of a document is for reference only. The English version shall prevail in case of any discrepancy between the translated and English versions.

## 18.4 Trademarks

Notice: All referenced brands, product names, service names and trademarks are the property of their respective owners.

## 19. Contact information

For more information, please visit: <http://www.nxp.com>

For sales office addresses, please send an email to: [salesaddresses@nxp.com](mailto:salesaddresses@nxp.com)

## 20. Contents

<b>1</b>	<b>General description</b> .....	<b>1</b>
<b>2</b>	<b>Features and benefits</b> .....	<b>1</b>
<b>3</b>	<b>Applications</b> .....	<b>1</b>
<b>4</b>	<b>Ordering information</b> .....	<b>1</b>
<b>5</b>	<b>Block diagram</b> .....	<b>2</b>
<b>6</b>	<b>Functional diagram</b> .....	<b>3</b>
<b>7</b>	<b>Pinning information</b> .....	<b>4</b>
7.1	Pinning .....	4
7.2	Pin description .....	4
<b>8</b>	<b>Functional description</b> .....	<b>5</b>
8.1	Level translator .....	5
8.2	Enable and direction control .....	6
8.3	Integrated voltage regulator .....	6
8.4	Memory card voltage tracking (reference select) .....	7
8.5	Feedback clock channel .....	7
8.6	EMI filter .....	7
8.7	ESD protection .....	7
<b>9</b>	<b>Limiting values</b> .....	<b>8</b>
<b>10</b>	<b>Recommended operating conditions</b> .....	<b>8</b>
<b>11</b>	<b>Static characteristics</b> .....	<b>9</b>
<b>12</b>	<b>Dynamic characteristics</b> .....	<b>11</b>
12.1	Voltage regulator .....	11
12.2	Level translator .....	12
12.3	ESD characteristic of pin write protect and card detect .....	13
<b>13</b>	<b>Test information</b> .....	<b>14</b>
<b>14</b>	<b>Package outline</b> .....	<b>15</b>
<b>15</b>	<b>Design and assembly recommendations</b> ...	<b>16</b>
15.1	PCB design guidelines .....	16
15.2	PCB assembly guidelines for Pb-free soldering .....	16
<b>16</b>	<b>Abbreviations</b> .....	<b>17</b>
<b>17</b>	<b>Revision history</b> .....	<b>18</b>
<b>18</b>	<b>Legal information</b> .....	<b>19</b>
18.1	Data sheet status .....	19
18.2	Definitions .....	19
18.3	Disclaimers .....	19
18.4	Trademarks .....	20
<b>19</b>	<b>Contact information</b> .....	<b>20</b>
<b>20</b>	<b>Contents</b> .....	<b>21</b>

Please be aware that important notices concerning this document and the product(s) described herein, have been included in section 'Legal information'.

© NXP Semiconductors N.V. 2014.

All rights reserved.

For more information, please visit: <http://www.nxp.com>

For sales office addresses, please send an email to: [salesaddresses@nxp.com](mailto:salesaddresses@nxp.com)

Date of release: 15 October 2014

Document identifier: IP4856CX25\_C