



High-Side Measurement Current-Shunt Monitor with Open-Drain Comparator and Reference

Check for Samples: [INA200-Q1](#), [INA201-Q1](#), [INA202-Q1](#)

FEATURES

- Qualified for Automotive Applications
- Complete Current Sense Solution
- 0.6-V Internal Voltage Reference
- Internal Open-Drain Comparator
- Latching Capability on Comparator
- Common-Mode Range: –16 V to 80 V
- High Accuracy: 3.5% Max Error Over Temperature
- Bandwidth: 500 kHz (INA200-Q1)
- Quiescent Current: 1800 μ A (Max)
- Latch-Up Exceeds 100mA per JESD78 - Class I
- Package: MSOP-8

APPLICATIONS

- Automotive
- Power Management
- Battery Chargers

DESCRIPTION

The INA200-Q1, INA201-Q1, and INA202-Q1 are high-side current-shunt monitors with voltage output. The INA200-Q1–INA202-Q1 can sense drops across shunts at common-mode voltages from –16V to 80V. The INA200-Q1–INA202-Q1 are available with three output voltage scales: 20V/V, 50V/V, and 100V/V, with up to 500kHz bandwidth.

The INA200-Q1, INA201-Q1, and INA202-Q1 also incorporate an open-drain comparator and internal reference providing a 0.6V threshold. External dividers are used to set the current trip point. The comparator includes a latching capability, which can be made transparent by grounding (or leaving open) the $\overline{\text{RESET}}$ pin.

The INA200-Q1, INA201-Q1, and INA202-Q1 operate from a single +2.7V to +18V supply, drawing a maximum of 1800 μ A of supply current. Package option include the very small MSOP-8. All versions are specified over the extended operating temperature range of –40°C to 125°C.

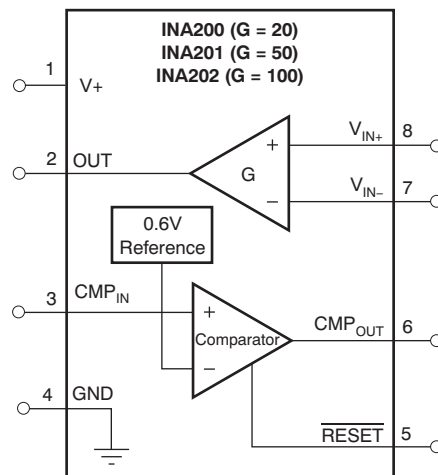

Please be aware that an important notice concerning availability, standard warranty, and use in critical applications of Texas Instruments semiconductor products and disclaimers thereto appears at the end of this data sheet.



This integrated circuit can be damaged by ESD. Texas Instruments recommends that all integrated circuits be handled with appropriate precautions. Failure to observe proper handling and installation procedures can cause damage.

ESD damage can range from subtle performance degradation to complete device failure. Precision integrated circuits may be more susceptible to damage because very small parametric changes could cause the device not to meet its published specifications.

ORDERING INFORMATION⁽¹⁾

T _A	PACKAGE		ORDERABLE PART NUMBER	TOP-SIDE MARKING
-40°C to 125°C	MSOP - DGK	Reel of 2500	INA200AQDGKRQ1	Product Preview
			INA201AQDGKRQ1	QWV
			INA202AQDGKRQ1	Product Preview

(1) For the most current package and ordering information see the Package Option Addendum at the end of this document, or see the device product folder at www.ti.com.

ABSOLUTE MAXIMUM RATINGS⁽¹⁾

	VALUE	UNIT
Supply Voltage, V ₊	18	V
Current-Shunt Monitor Analog Inputs, V _{IN+} , V _{IN-}		
Differential (V _{IN+}) – (V _{IN-})	–18 to +18	V
Common Mode ⁽²⁾	–16 to +80	V
Comparator Analog Input and Reset Pins ⁽²⁾	GND – 0.3 to (V ₊) + 0.3	V
Analog Output, Out ⁽²⁾	GND – 0.3 to (V ₊) + 0.3	V
Comparator Output, Out Pin ⁽²⁾	GND – 0.3 to 18	V
Input Current Into Any Pin ⁽²⁾	5	mA
Storage Temperature	–65 to +150	°C
Junction Temperature	+150	°C

- (1) Stresses above these ratings may cause permanent damage. Exposure to absolute maximum conditions for extended periods may degrade device reliability. These are stress ratings only, and functional operation of the device at these or any other conditions beyond those specified is not supported.
- (2) This voltage may exceed the ratings shown if the current at that pin is limited to 5mA.

Figure 1. PIN CONFIGURATIONS

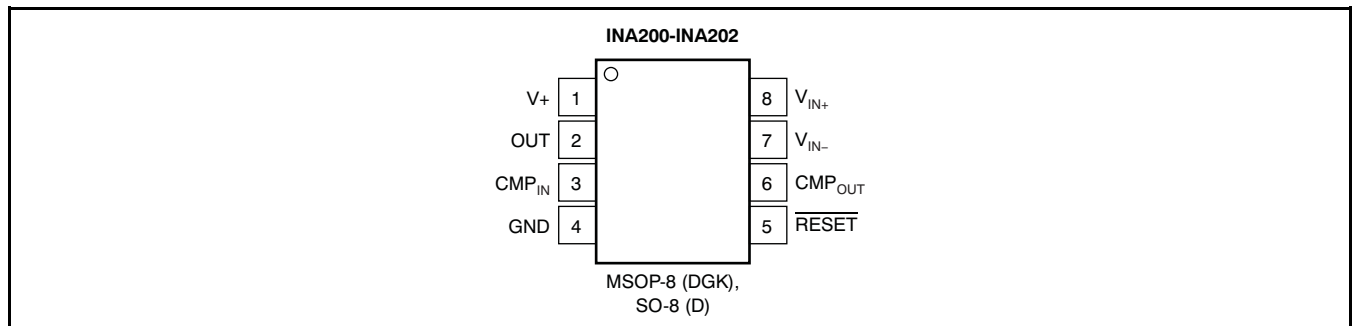

ELECTRICAL CHARACTERISTICS: CURRENT-SHUNT MONITOR
Boldface limits apply over the specified temperature range: $T_A = -40^{\circ}\text{C}$ to $+125^{\circ}\text{C}$.

At $T_A = +25^{\circ}\text{C}$, $V_S = +12\text{V}$, $V_{CM} = +12\text{V}$, $V_{SENSE} = 100\text{mV}$, $R_L = 10\text{k}\Omega$ to GND, $R_{PULL-UP} = 5.1\text{k}\Omega$ connected from CMP_{OUT} to V_S , and $\text{CMP}_{IN} = \text{GND}$, unless otherwise noted.

CURRENT-SHUNT MONITOR PARAMETERS	CONDITIONS	INA200-Q1, INA201-Q1, INA202-Q1			UNIT
		MIN	TYP	MAX	
INPUT					
Full-Scale Sense Input Voltage	V_{SENSE}	$V_{SENSE} = V_{IN+} - V_{IN-}$	0.15	$(V_S - 0.25)/\text{Gain}$	V
Common-Mode Input Range	V_{CM}		-16	80	V
Common-Mode Rejection	CMR	$V_{IN+} = -16\text{V}$ to $+80\text{V}$	80	100	dB
Over Temperature		$V_{IN+} = +12\text{V}$ to $+80\text{V}$	100	123	dB
Offset Voltage, RTI ⁽¹⁾	V_{OS}		± 0.5	± 2.5	mV
+25°C to +125°C				± 3	mV
-40°C to +25°C				± 3.5	mV
vs Temperature	dV_{OS}/dT	T_{MIN} to T_{MAX}	5		$\mu\text{V}/^{\circ}\text{C}$
vs Power Supply	PSR	$V_{OUT} = 2\text{V}$, $V_{IN+} = +18\text{V}$, 2.7V	2.5	100	$\mu\text{V}/\text{V}$
Input Bias Current, V_{IN-} Pin	I_B		± 9	± 16	μA
OUTPUT ($V_{SENSE} \geq 20\text{mV}$)					
Gain:	G				
INA200-Q1			20		V/V
INA201-Q1			50		V/V
INA202-Q1			100		V/V
Gain Error		$V_{SENSE} = 20\text{mV}$ to 100mV	± 0.2	± 1	%
Over Temperature		$V_{SENSE} = 20\text{mV}$ to 100mV		± 2	%
Total Output Error ⁽²⁾		$V_{SENSE} = 120\text{mV}$, $V_S = +16\text{V}$	± 0.75	± 2.2	%
Over Temperature		$V_{SENSE} = 120\text{mV}$, $V_S = +16\text{V}$		± 3.5	%
Nonlinearity Error ⁽³⁾		$V_{SENSE} = 20\text{mV}$ to 100mV	± 0.002		%
Output Impedance	R_O		1.5		Ω
Maximum Capacitive Load		No Sustained Oscillation	10		nF
OUTPUT ($V_{SENSE} < 20\text{mV}$)⁽⁴⁾					
INA200-Q1, INA201-Q1, INA202-Q1		$-16\text{V} \leq V_{CM} < 0\text{V}$	300		mV
INA200-Q1		$0\text{V} \leq V_{CM} \leq V_S$, $V_S = 5\text{V}$		0.4	V
INA201-Q1		$0\text{V} \leq V_{CM} \leq V_S$, $V_S = 5\text{V}$		1	V
INA202-Q1		$0\text{V} \leq V_{CM} \leq V_S$, $V_S = 5\text{V}$		2	V
INA200-Q1, INA201-Q1, INA202-Q1		$V_S < V_{CM} \leq 80\text{V}$	300		mV
VOLTAGE OUTPUT⁽⁵⁾					
Output Swing to the Positive Rail		$V_{IN-} = 11\text{V}$, $V_{IN+} = 12\text{V}$	(V+) - 0.15	(V+) - 0.25	V
Output Swing to GND⁽⁶⁾		$V_{IN-} = 0\text{V}$, $V_{IN+} = -0.5\text{V}$	(V_GND) + 0.004	(V_GND) + 0.05	V
FREQUENCY RESPONSE					
Bandwidth:	BW				
INA200-Q1		$C_{LOAD} = 5\text{pF}$	500		kHz
INA201-Q1		$C_{LOAD} = 5\text{pF}$	300		kHz
INA202-Q1		$C_{LOAD} = 5\text{pF}$	200		kHz
Phase Margin		$C_{LOAD} < 10\text{nF}$	40		Degrees
Slew Rate	SR		1		V/ μs
Settling Time (1%)		$V_{SENSE} = 10\text{mV}_{PP}$ to 100mV_{PP} , $C_{LOAD} = 5\text{pF}$	2		μs
NOISE, RTI					
Voltage Noise Density			40		$\text{nV}/\sqrt{\text{Hz}}$

(1) Offset is extrapolated from measurements of the output at 20mV and 100mV V_{SENSE} .

(2) Total output error includes effects of gain error and V_{OS} .

(3) Linearity is best fit to a straight line.

(4) For details on this region of operation, see the [Accuracy Variations](#) section in the [Applications Information](#).

(5) See Typical Characteristic curve *Output Swing vs Output Current*.

(6) Specified by design.

ELECTRICAL CHARACTERISTICS: COMPARATOR

Boldface limits apply over the specified temperature range: $T_A = -40^{\circ}\text{C}$ to $+125^{\circ}\text{C}$.

At $T_A = +25^{\circ}\text{C}$, $V_S = +12\text{V}$, $V_{CM} = +12\text{V}$, $V_{SENSE} = 100\text{mV}$, $R_L = 10\text{k}\Omega$ to GND, and $R_{PULL-UP} = 5.1\text{k}\Omega$ connected from CMP_{OUT} to V_S , unless otherwise noted.

COMPARATOR PARAMETERS	CONDITIONS	INA200-Q1, INA201-Q1, INA202-Q1			UNIT
		MIN	TYP	MAX	
OFFSET VOLTAGE					
Threshold	$T_A = +25^{\circ}\text{C}$	590	608	620	mV
Over Temperature		586		625	mV
Hysteresis ⁽¹⁾	$T_A = -40^{\circ}\text{C}$ to $+85^{\circ}\text{C}$		-8		mV
INPUT BIAS CURRENT⁽²⁾					
CMP_{IN} Pin			0.005	10	nA
vs Temperature				15	nA
INPUT VOLTAGE RANGE					
CMP_{IN} Pin			0V to $V_S - 1.5\text{V}$		V
OUTPUT (OPEN-DRAIN)					
Large-Signal Differential Voltage Gain	CMP V_{OUT} 1V to 4V, $R_L \geq 15\text{k}\Omega$ Connected to 5V		200		V/mV
High-Level Leakage Current ⁽³⁾ ⁽⁴⁾	I_{LKG} $V_{ID} = 0.4\text{V}$, $V_{OH} = V_S$		0.0001	1	μA
Low-Level Output Voltage ⁽³⁾	V_{OL} $V_{ID} = -0.6\text{V}$, $I_{OL} = 2.35\text{mA}$		220	300	mV
RESPONSE TIME					
Response Time ⁽⁵⁾	R_L to 5V, $C_L = 15\text{pF}$, 100mV Input Step with 5mV Overdrive		1.3		μs
RESET					
$\overline{\text{RESET}}$ Threshold ⁽⁶⁾			1.1		V
Logic Input Impedance			2		M Ω
Minimum $\overline{\text{RESET}}$ Pulse Width			1.5		μs
$\overline{\text{RESET}}$ Propagation Delay			3		μs

- (1) Hysteresis refers to the threshold (the threshold specification applies to a rising edge of a noninverting input) of a falling edge on the noninverting input of the comparator; refer to [Figure 2](#).
- (2) Specified by design.
- (3) V_{ID} refers to the differential voltage at the comparator inputs.
- (4) Open-drain output can be pulled to the range of +2.7V to +18V, regardless of V_S .
- (5) The comparator response time specified is the interval between the input step function and the instant when the output crosses 1.4V.
- (6) The $\overline{\text{RESET}}$ input has an internal 2M Ω (typical) pull-down. Leaving $\overline{\text{RESET}}$ open results in a LOW state, with transparent comparator operation.

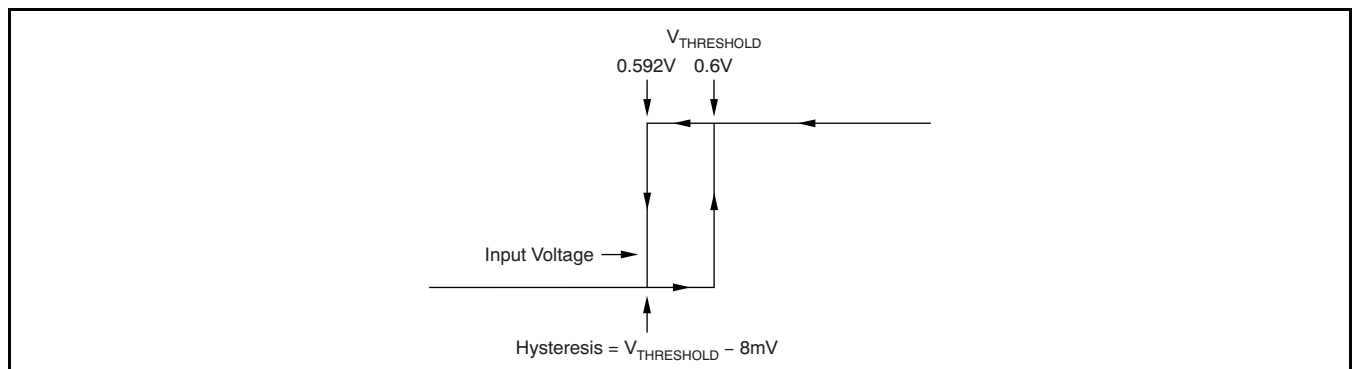

Figure 2. Typical Comparator Hysteresis

ELECTRICAL CHARACTERISTICS: GENERAL

Boldface limits apply over the specified temperature range: $T_A = -40^{\circ}\text{C}$ to $+125^{\circ}\text{C}$.

At $T_A = +25^{\circ}\text{C}$, $V_S = +12\text{V}$, $V_{CM} = +12\text{V}$, $V_{SENSE} = 100\text{mV}$, $R_L = 10\text{k}\Omega$ to GND, $R_{PULL-UP} = 5.1\text{k}\Omega$ connected from CMP_{OUT} to V_S , and $\text{CMP}_{IN} = 1\text{V}$, unless otherwise noted.

GENERAL PARAMETERS	CONDITIONS	INA200-Q1, INA201-Q1, INA202-Q1			UNIT
		MIN	TYP	MAX	
POWER SUPPLY					
Operating Power Supply	V_S	+2.7		+18	V
Quiescent Current	I_Q		1350	1800	μA
Over Temperature				1850	μA
Comparator Power-On Reset Threshold ⁽¹⁾			1.5		V
TEMPERATURE					
Operating Temperature Range		-40		+125	$^{\circ}\text{C}$
Storage Temperature Range		-65		+150	$^{\circ}\text{C}$
Thermal Resistance	θ_{JA}				
MSOP-8 Surface-Mount			200		$^{\circ}\text{C}/\text{W}$

- (1) The INA200-Q1, INA201-Q1, and INA202-Q1 are designed to power-up with the comparator in a defined reset state as long as $\overline{\text{RESET}}$ is open or grounded. The comparator is in reset as long as the power supply is below the voltage shown here. The comparator assumes a state based on the comparator input above this supply voltage. If $\overline{\text{RESET}}$ is high at power-up, the comparator output comes up high and requires a reset to assume a low state, if appropriate.

TYPICAL CHARACTERISTICS

At $T_A = +25^\circ\text{C}$, $V_S = +12\text{V}$, $V_{IN+} = 12\text{V}$, and $V_{SENSE} = 100\text{mV}$, unless otherwise noted.

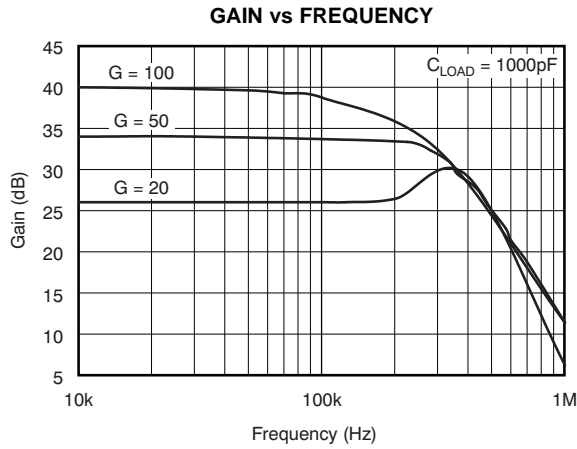

Figure 3.

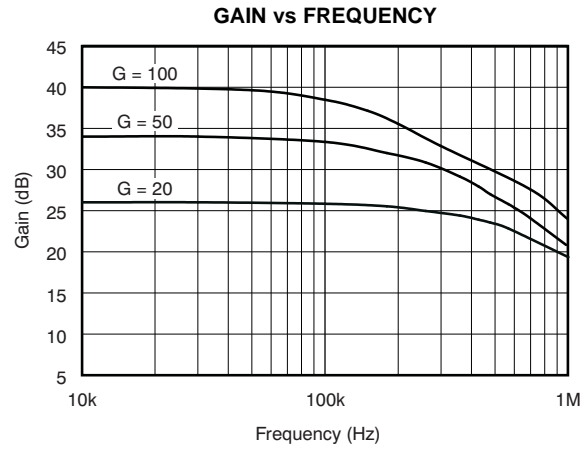

Figure 4.

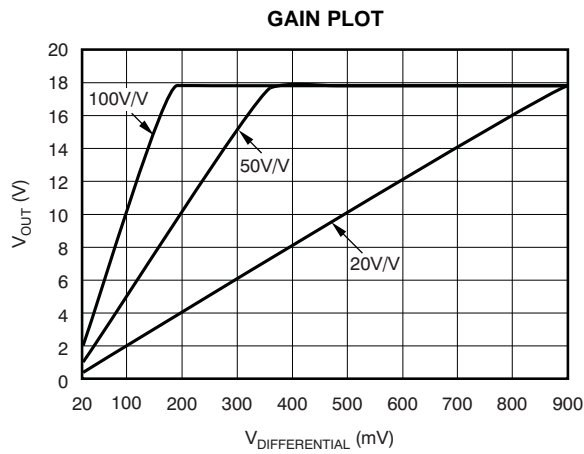

Figure 5.

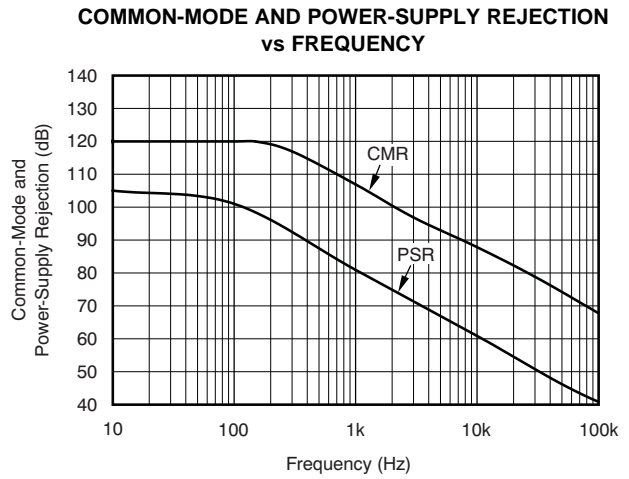

Figure 6.

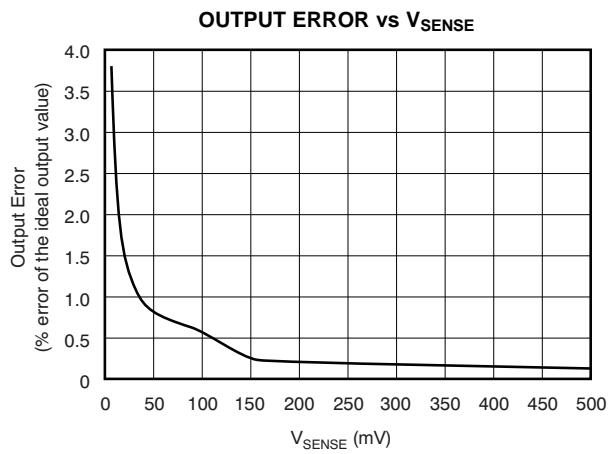

Figure 7.

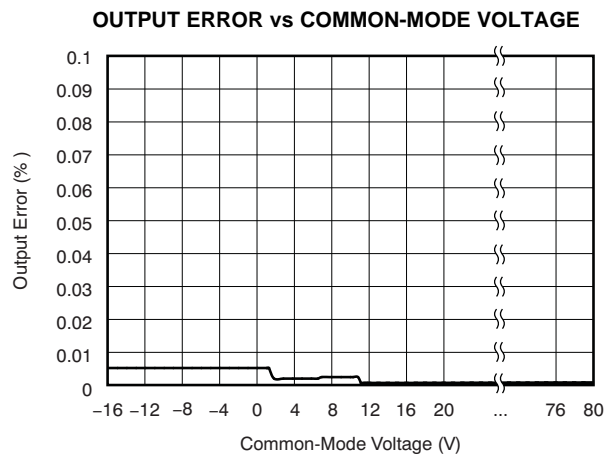

Figure 8.

TYPICAL CHARACTERISTICS (continued)

At $T_A = +25^\circ\text{C}$, $V_S = +12\text{V}$, $V_{IN+} = 12\text{V}$, and $V_{SENSE} = 100\text{mV}$, unless otherwise noted.

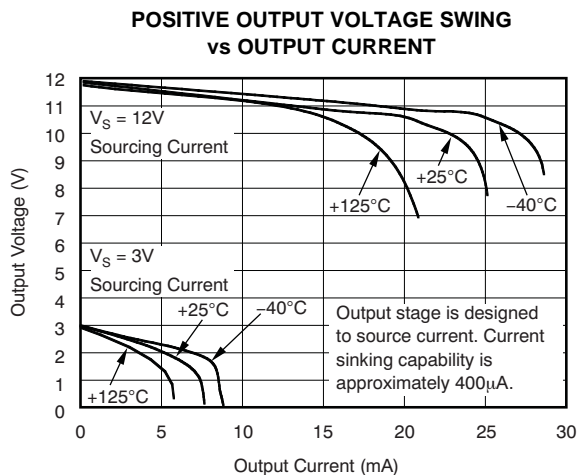

Figure 9.

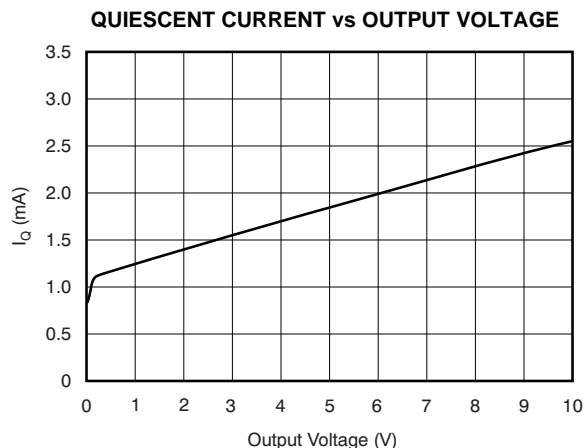

Figure 10.

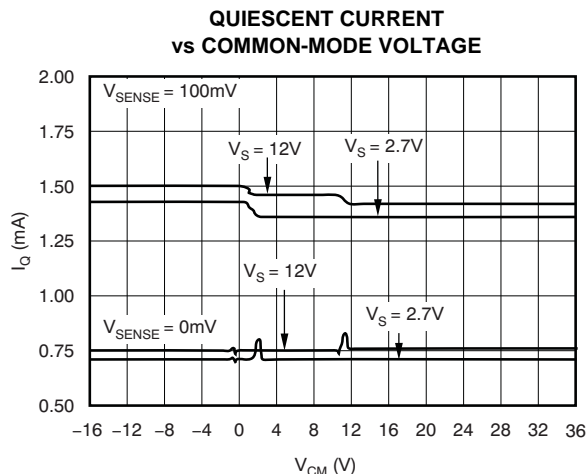

Figure 11.

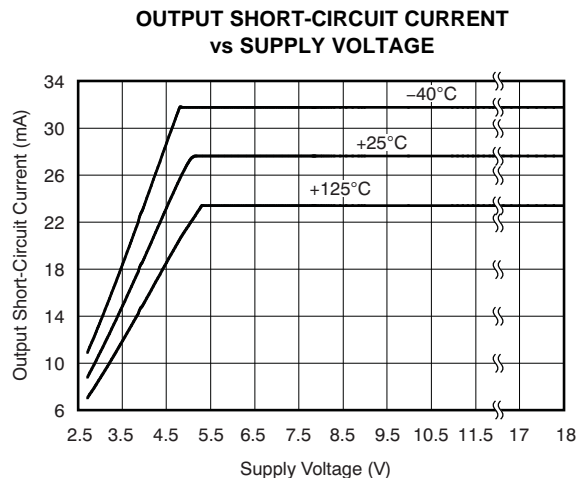

Figure 12.

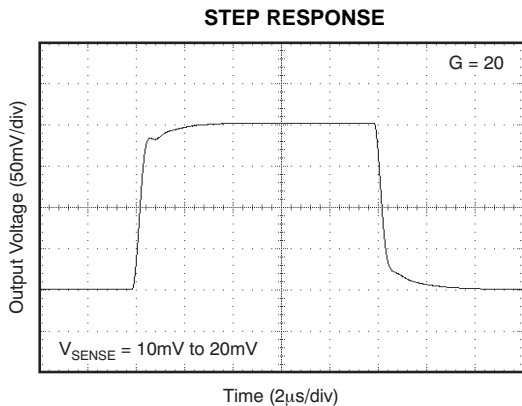

Figure 13.

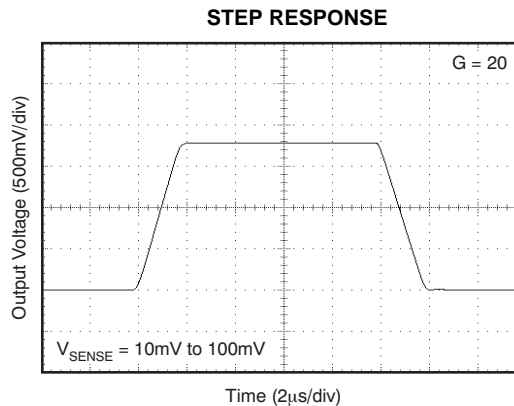

Figure 14.

TYPICAL CHARACTERISTICS (continued)

At $T_A = +25^\circ\text{C}$, $V_S = +12\text{V}$, $V_{IN+} = 12\text{V}$, and $V_{SENSE} = 100\text{mV}$, unless otherwise noted.

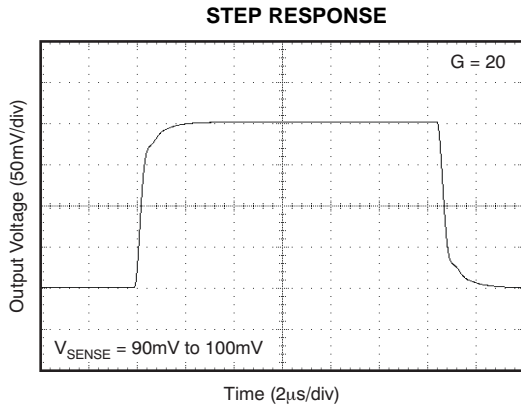

Figure 15.

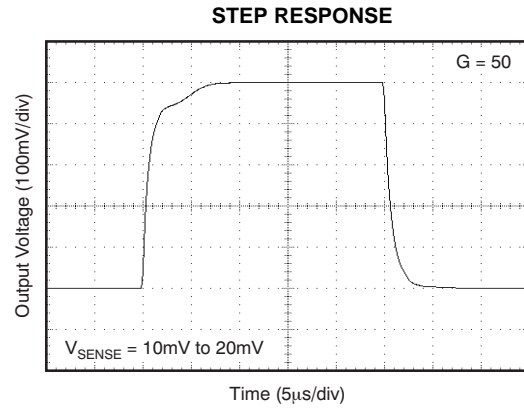

Figure 16.

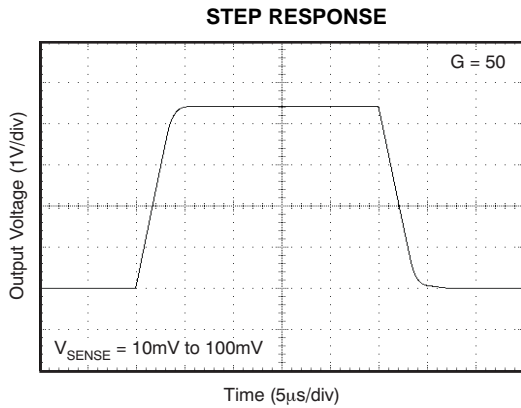

Figure 17.

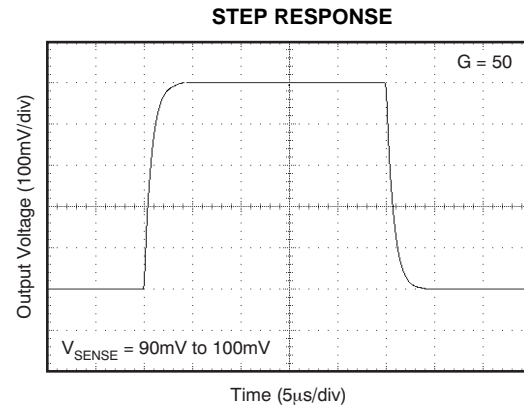

Figure 18.

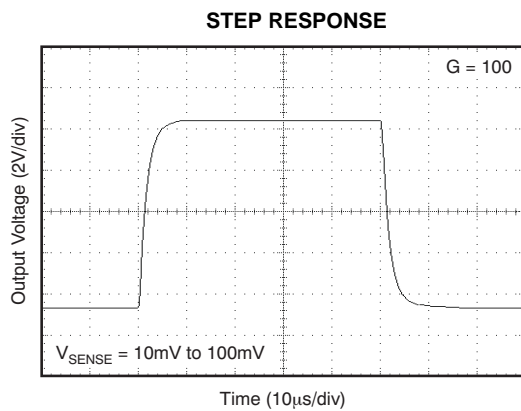

Figure 19.

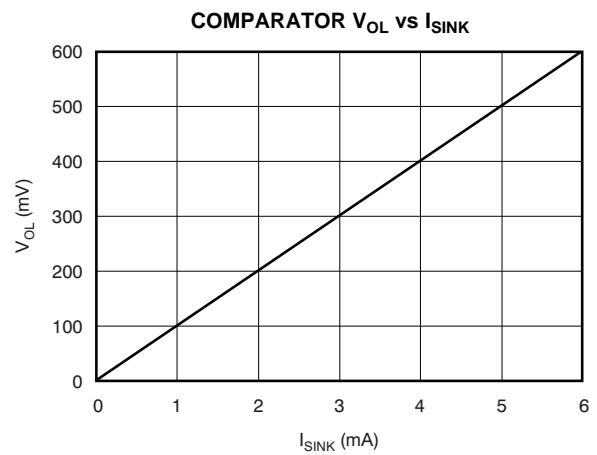

Figure 20.

TYPICAL CHARACTERISTICS (continued)

At $T_A = +25^\circ\text{C}$, $V_S = +12\text{V}$, $V_{IN+} = 12\text{V}$, and $V_{SENSE} = 100\text{mV}$, unless otherwise noted.

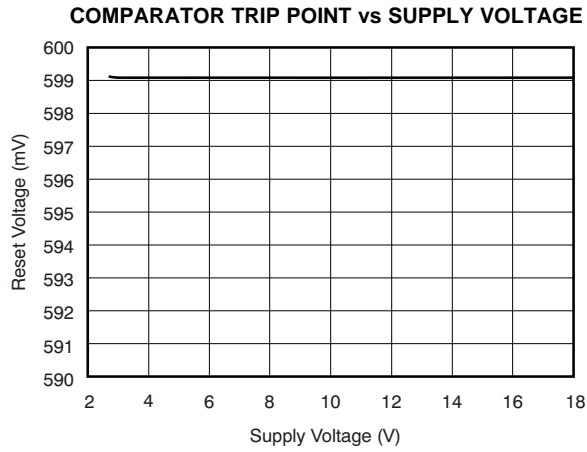

Figure 21.

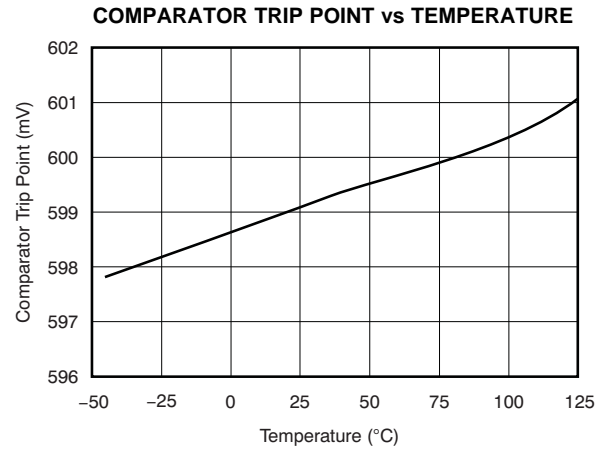

Figure 22.

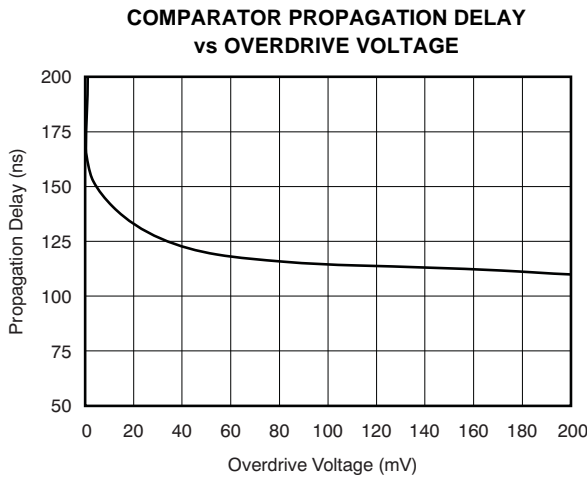

Figure 23.

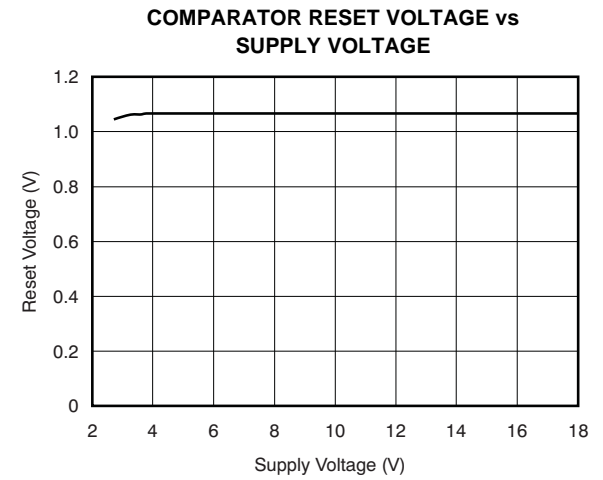

Figure 24.

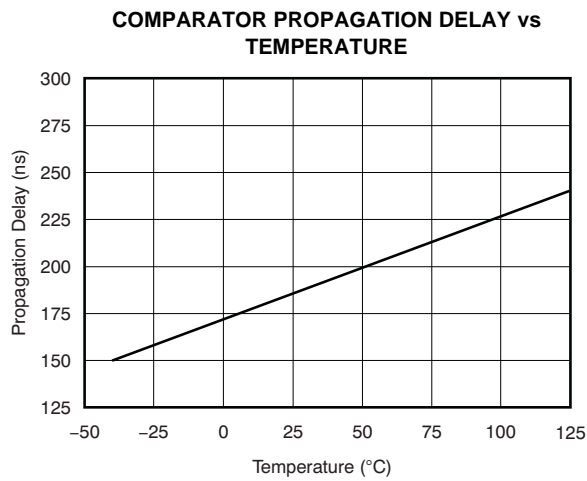

Figure 25.

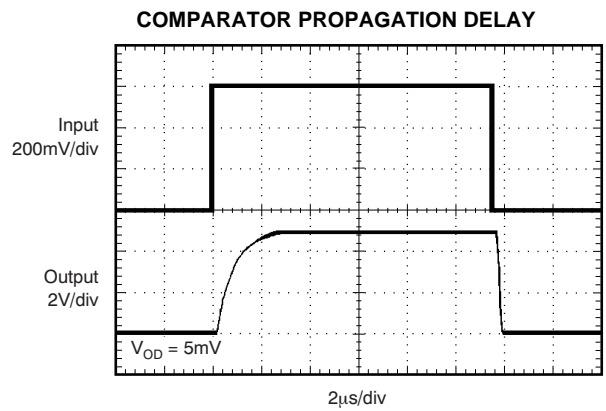

Figure 26.

APPLICATIONS INFORMATION

BASIC CONNECTIONS

Figure 27 shows the basic connections of the INA200-Q1, INA201-Q1, and INA202-Q1. The input pins, V_{IN+} and V_{IN-} , should be connected as closely as possible to the shunt resistor to minimize any resistance in series with the shunt resistance.

Power-supply bypass capacitors are required for stability. Applications with noisy or high-impedance power supplies may require additional decoupling capacitors to reject power-supply noise. Connect bypass capacitors close to the device pins.

POWER SUPPLY

The input circuitry of the INA200-Q1, INA201-Q1, and INA202-Q1 can accurately measure beyond the power-supply voltage, $V+$. For example, the $V+$ power supply can be 5V, whereas the load power-supply voltage is up to +80V. The output voltage range of the OUT terminal, however, is limited by the voltages on the power-supply pin.

ACCURACY VARIATIONS AS A RESULT OF V_{SENSE} AND COMMON-MODE VOLTAGE

The accuracy of the INA200-Q1, INA201-Q1, and INA202-Q1 current shunt monitors is a function of two main variables: V_{SENSE} ($V_{IN+} - V_{IN-}$) and common-mode voltage, V_{CM} , relative to the supply voltage, V_S . V_{CM} is expressed as $(V_{IN+} + V_{IN-})/2$; however, in practice, V_{CM} is seen as the voltage at V_{IN+} because the voltage drop across V_{SENSE} is usually small.

This section addresses the accuracy of these specific operating regions:

- Normal Case 1: $V_{SENSE} \geq 20\text{mV}$, $V_{CM} \geq V_S$
- Normal Case 2: $V_{SENSE} \geq 20\text{mV}$, $V_{CM} < V_S$
- Low V_{SENSE} Case 1: $V_{SENSE} < 20\text{mV}$, $-16\text{V} \leq V_{CM} < 0$
- Low V_{SENSE} Case 2: $V_{SENSE} < 20\text{mV}$, $0\text{V} \leq V_{CM} \leq V_S$
- Low V_{SENSE} Case 3: $V_{SENSE} < 20\text{mV}$, $V_S < V_{CM} \leq 80\text{V}$

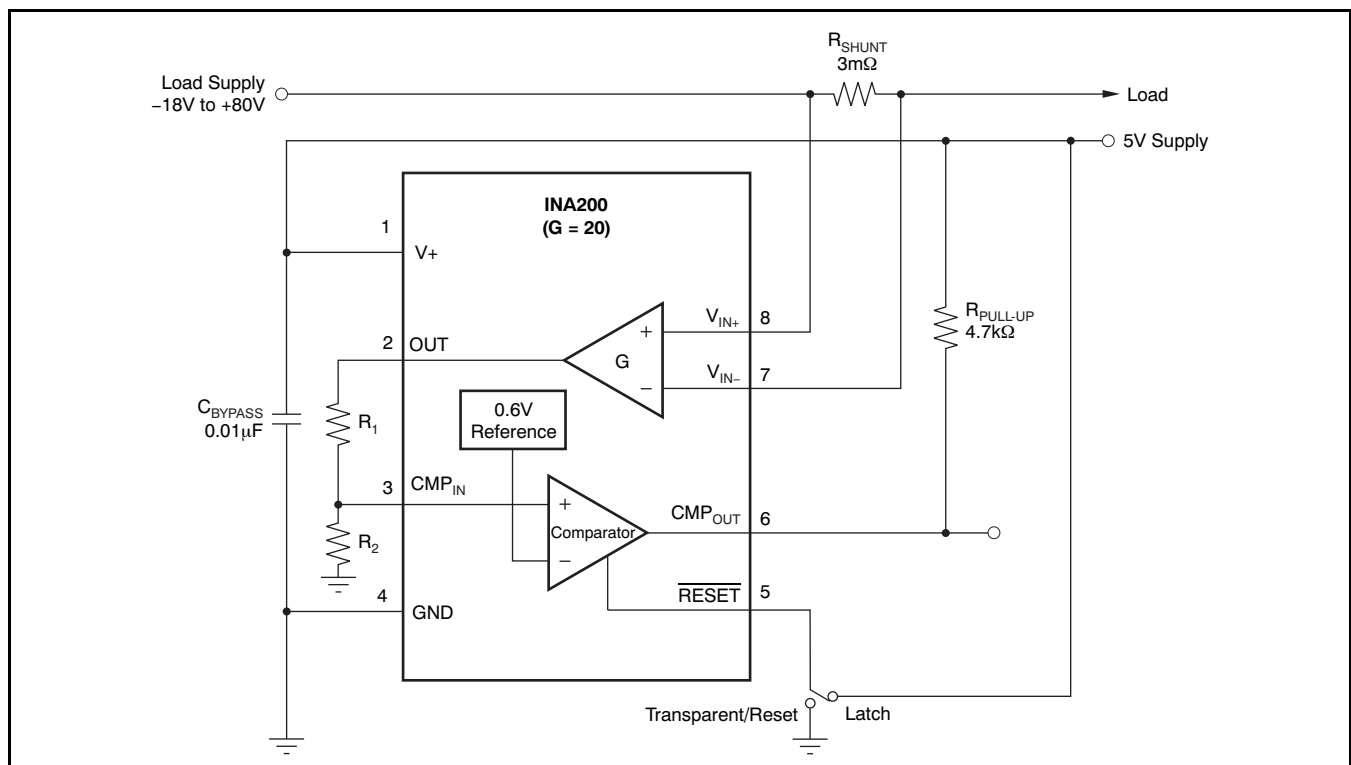

Figure 27. INA200-Q1 Basic Connections

Normal Case 1: $V_{SENSE} \geq 20\text{mV}$, $V_{CM} \geq V_S$

This region of operation provides the highest accuracy. Here, the input offset voltage is characterized and measured using a two-step method. First, the gain is determined by Equation 1.

$$G = \frac{V_{OUT1} - V_{OUT2}}{100\text{mV} - 20\text{mV}} \quad (1)$$

where:

V_{OUT1} = Output Voltage with $V_{SENSE} = 100\text{mV}$

V_{OUT2} = Output Voltage with $V_{SENSE} = 20\text{mV}$

Then the offset voltage is measured at $V_{SENSE} = 100\text{mV}$ and referred to the input (RTI) of the current shunt monitor, as shown in Equation 2.

$$V_{OS\text{RTI}} \text{ (Referred-To-Input)} = \left[\frac{V_{OUT1}}{G} \right] - 100\text{mV} \quad (2)$$

In the [Typical Characteristics](#), the *Output Error vs Common-Mode Voltage* curve (Figure 8) shows the highest accuracy for the this region of operation. In this plot, $V_S = 12\text{V}$; for $V_{CM} \geq 12\text{V}$, the output error is at its minimum. This case is also used to create the $V_{SENSE} \geq 20\text{mV}$ output specifications in the [Electrical Characteristics](#) table.

Normal Case 2: $V_{SENSE} \geq 20\text{mV}$, $V_{CM} < V_S$

This region of operation has slightly less accuracy than Normal Case 1 as a result of the common-mode operating area in which the part functions, as seen in the *Output Error vs Common-Mode Voltage* curve (Figure 8). As noted, for this graph $V_S = 12\text{V}$; for $V_{CM} < 12\text{V}$, the Output Error increases as V_{CM} becomes less than 12V , with a typical maximum error of 0.005% at the most negative $V_{CM} = -16\text{V}$.

Low V_{SENSE} Case 1:
 $V_{SENSE} < 20\text{mV}$, $-16\text{V} \leq V_{CM} < 0$; and
Low V_{SENSE} Case 3:
 $V_{SENSE} < 20\text{mV}$, $V_S < V_{CM} \leq 80\text{V}$

Although the INA200-Q1 family of devices are not designed for accurate operation in either of these regions, some applications are exposed to these conditions. For example, when monitoring power supplies that are switched on and off while V_S is still applied to the INA200-Q1, INA201-Q1, or INA202-Q1, it is important to know what the behavior of the devices will be in these regions.

As V_{SENSE} approaches 0mV , in these V_{CM} regions, the device output accuracy degrades. A

larger-than-normal offset can appear at the current shunt monitor output with a typical maximum value of $V_{OUT} = 300\text{mV}$ for $V_{SENSE} = 0\text{mV}$. As V_{SENSE} approaches 20mV , V_{OUT} returns to the expected output value with accuracy as specified in the [Electrical Characteristics](#). Figure 28 illustrates this effect using the INA202-Q1 (Gain = 100).

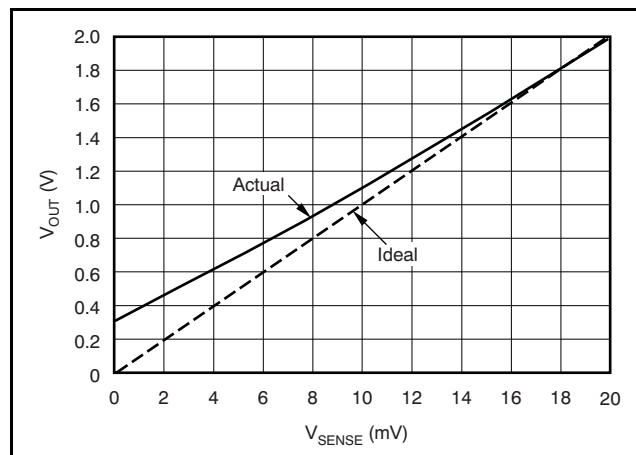

Figure 28. Example for Low V_{SENSE} Cases 1 and 3 (INA202-Q1, Gain = 100)

Low V_{SENSE} Case 2: $V_{SENSE} < 20\text{mV}$, $0\text{V} \leq V_{CM} \leq V_S$

This region of operation is the least accurate for the INA200-Q1 family. To achieve the wide input common-mode voltage range, these devices use two op amp front ends in parallel. One op amp front end operates in the positive input common-mode voltage range, and the other in the negative input region. For this case, neither of these two internal amplifiers dominates and overall loop gain is very low. Within this region, V_{OUT} approaches voltages close to linear operation levels for Normal Case 2. This deviation from linear operation becomes greatest the closer V_{SENSE} approaches 0V . Within this region, as V_{SENSE} approaches 20mV , device operation is closer to that described by Normal Case 2. Figure 29 illustrates this behavior for the INA202-Q1. The V_{OUT} maximum peak for this case is tested by maintaining a constant V_S , setting $V_{SENSE} = 0\text{mV}$ and sweeping V_{CM} from 0V to V_S . The exact V_{CM} at which V_{OUT} peaks during this test varies from part to part, but the V_{OUT} maximum peak is tested to be less than the specified V_{OUT} tested limit.

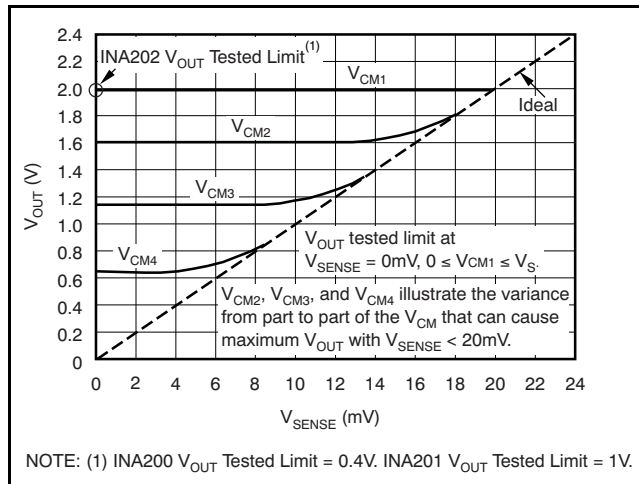

Figure 29. Example for Low V_{SENSE} Case 2 (INA202-Q1, Gain = 100)

SELECTING R_S

The value chosen for the shunt resistor, R_S , depends on the application and is a compromise between small-signal accuracy and maximum permissible voltage loss in the measurement line. High values of R_S provide better accuracy at lower currents by minimizing the effects of offset, while low values of R_S minimize voltage loss in the supply line. For most applications, best performance is attained with an R_S value that provides a full-scale shunt voltage range of 50mV to 100mV. Maximum input voltage for accurate measurements is 500mV.

TRANSIENT PROTECTION

The $-16V$ to $+80V$ common-mode range of the INA200-Q1, INA201-Q1, and INA202-Q1 is ideal for withstanding automotive fault conditions ranging from 12V battery reversal up to $+80V$ transients, since no additional protective components are needed up to those levels. In the event that the INA200-Q1, INA201-Q1, and INA202-Q1 are exposed to transients on the inputs in excess of their ratings, then external transient absorption with semiconductor transient absorbers (such as zeners) will be necessary. Use of MOVs or VDRs is not recommended except when they are used in addition to a semiconductor transient absorber. Select the transient absorber such that it will never allow the INA200-Q1, INA201-Q1, and INA202-Q1 to be exposed to transients greater than $+80V$ (that is, allow for transient absorber tolerance, as well as additional voltage due to transient absorber dynamic impedance). Despite the use of internal zener-type ESD protection, the INA200-Q1, INA201-Q1, and INA202-Q1 do not lend themselves to using external

resistors in series with the inputs since the internal gain resistors can vary up to $\pm 30\%$. (If gain accuracy is not important, then resistors can be added in series with the INA200-Q1, INA201-Q1, and INA202-Q1 inputs with two equal resistors on each input.)

OUTPUT VOLTAGE RANGE

The output of the INA200-Q1, INA201-Q1, and INA202-Q1 is accurate within the output voltage swing range set by the power supply pin, V_+ . This performance is best illustrated when using the INA202-Q1 (a gain of 100 version), where a 100mV full-scale input from the shunt resistor requires an output voltage swing of $+10V$, and a power-supply voltage sufficient to achieve $+10V$ on the output.

INPUT FILTERING

An obvious and straightforward location for filtering is at the output of the INA200-Q1, INA201-Q1, and INA202-Q1 series; however, this location negates the advantage of the low output impedance of the internal buffer. The only other option for filtering is at the input pins of the INA200-Q1, INA201-Q1, and INA202-Q1, which is complicated by the internal $5k\Omega$ and 30% input impedance; this is illustrated in Figure 30. Using the lowest possible resistor values minimizes both the initial shift in gain and effects of tolerance. The effect on initial gain is given by Equation 3:

$$\text{Gain Error \%} = 100 - \left[100 \times \frac{5k\Omega}{5k\Omega + R_{\text{FILT}}} \right] \quad (3)$$

Total effect on gain error can be calculated by replacing the $5k\Omega$ term with $5k\Omega - 30\%$ (or $3.5k\Omega$) or $5k\Omega + 30\%$ (or $6.5k\Omega$). The tolerance extremes of R_{FILT} can also be inserted into the equation. If a pair of 100 Ω 1% resistors are used on the inputs, the initial gain error will be 1.96%. Worst-case tolerance conditions will always occur at the lower excursion of the internal $5k\Omega$ resistor ($3.5k\Omega$), and the higher excursion of $R_{\text{FILT}} - 3\%$ in this case.

Note that the specified accuracy of the INA200-Q1, INA201-Q1, and INA202-Q1 must then be combined in addition to these tolerances. While this discussion treated accuracy worst-case conditions by combining the extremes of the resistor values, it is appropriate to use geometric mean or root sum square calculations to total the effects of accuracy variations.

COMPARATOR

The INA200-Q1, INA201-Q1, and INA202-Q1 devices incorporate an open-drain comparator. This comparator typically has 2mV of offset and a 1.3 μs (typical) response time. The output of the comparator latches and is reset through the RESET pin; see Figure 31.

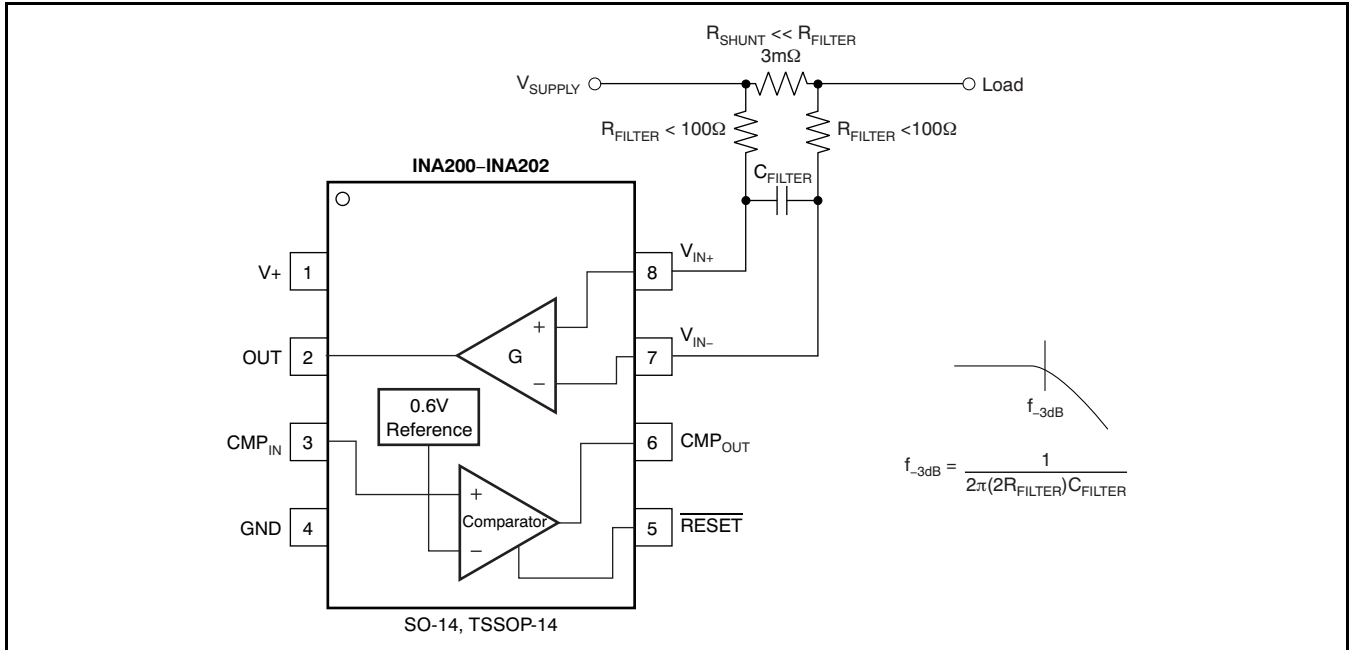

Figure 30. Input Filter (Gain Error—1.5% to –2.2%)

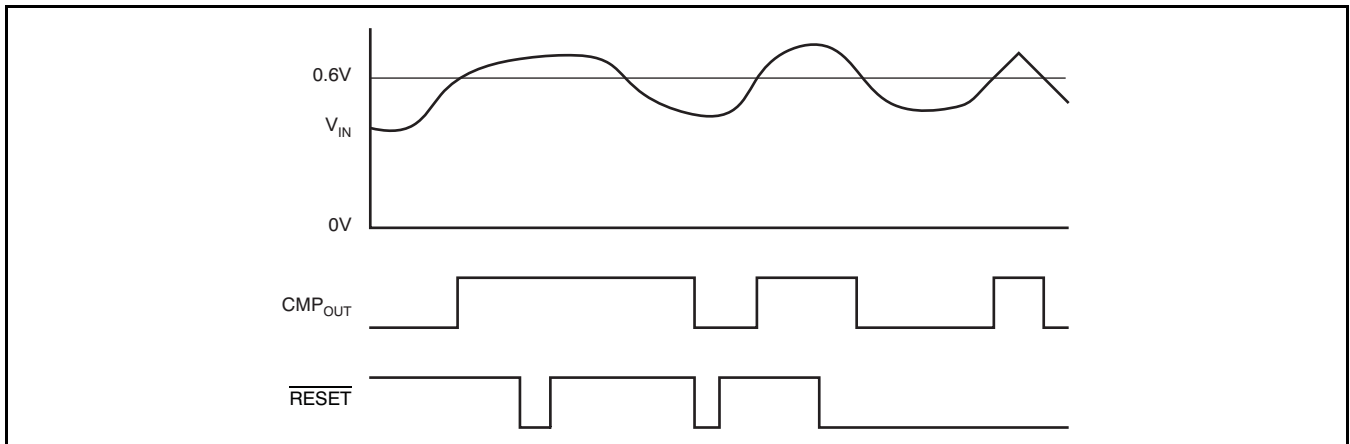

Figure 31. Comparator Latching Capability

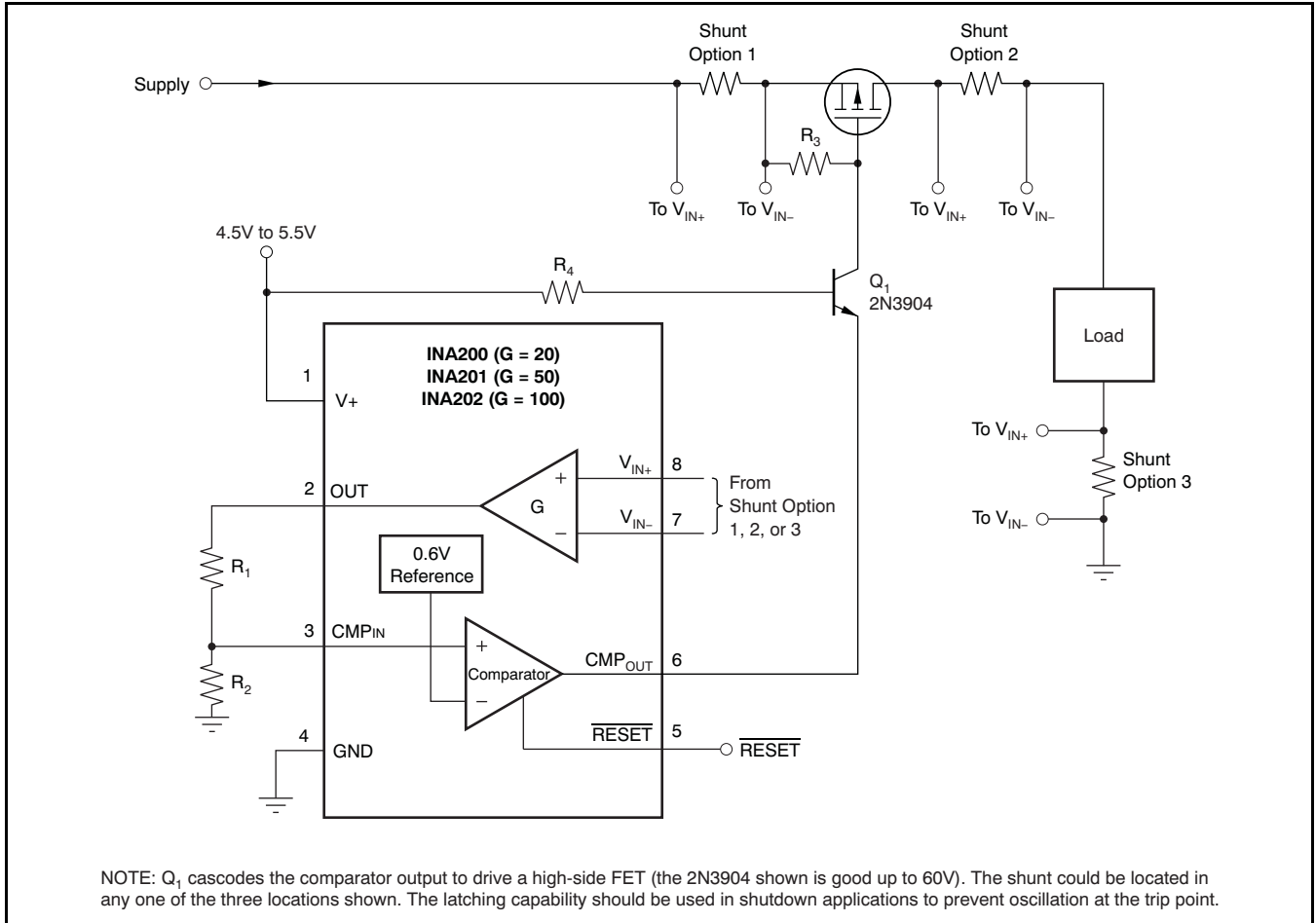

Figure 32. High-Side Switch Over-Current Shutdown

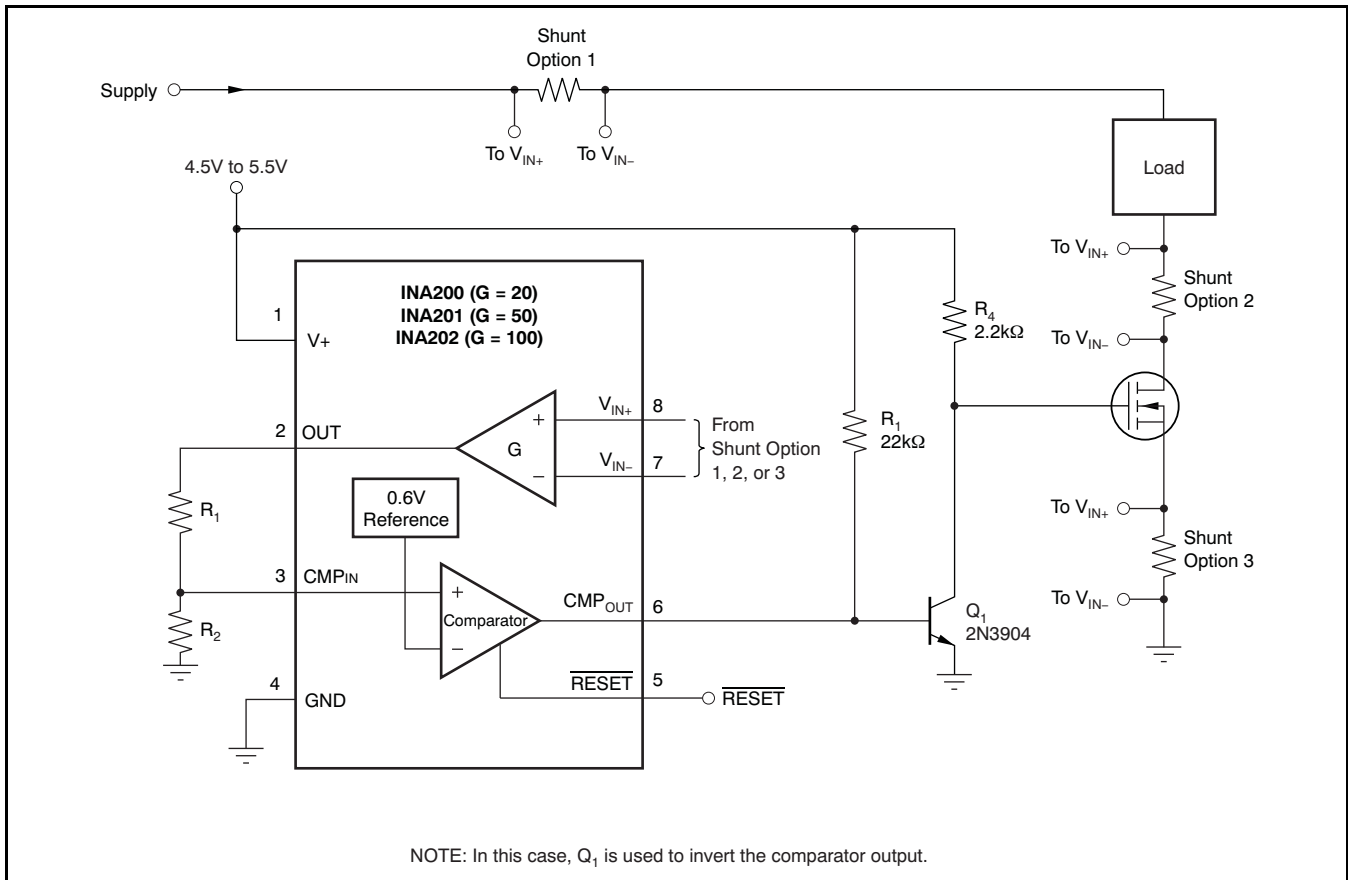

Figure 33. Low-Side Switch Over-Current Shutdown

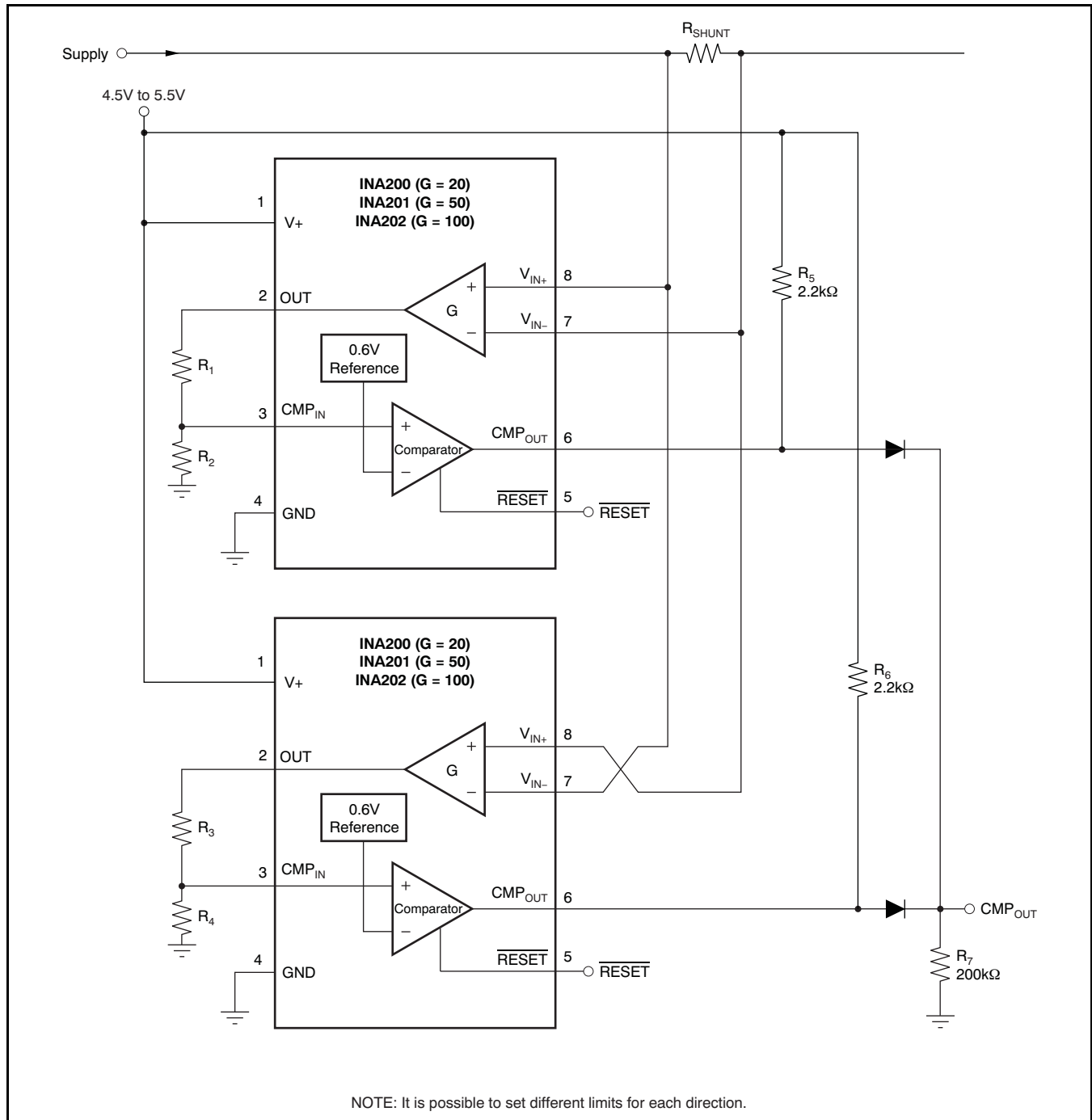

Figure 34. Bidirectional Over-Current Comparator

PACKAGING INFORMATION

Orderable Device	Status ⁽¹⁾	Package Type	Package Drawing	Pins	Package Qty	Eco Plan ⁽²⁾	Lead/ Ball Finish	MSL Peak Temp ⁽³⁾	Samples (Requires Login)
INA201AQDGKRQ1	ACTIVE	VSSOP	DGK	8	2500	Green (RoHS & no Sb/Br)	CU NIPDAU	Level-2-260C-1 YEAR	

⁽¹⁾ The marketing status values are defined as follows:

ACTIVE: Product device recommended for new designs.

LIFEBUY: TI has announced that the device will be discontinued, and a lifetime-buy period is in effect.

NRND: Not recommended for new designs. Device is in production to support existing customers, but TI does not recommend using this part in a new design.

PREVIEW: Device has been announced but is not in production. Samples may or may not be available.

OBSOLETE: TI has discontinued the production of the device.

⁽²⁾ Eco Plan - The planned eco-friendly classification: Pb-Free (RoHS), Pb-Free (RoHS Exempt), or Green (RoHS & no Sb/Br) - please check <http://www.ti.com/productcontent> for the latest availability information and additional product content details.

TBD: The Pb-Free/Green conversion plan has not been defined.

Pb-Free (RoHS): TI's terms "Lead-Free" or "Pb-Free" mean semiconductor products that are compatible with the current RoHS requirements for all 6 substances, including the requirement that lead not exceed 0.1% by weight in homogeneous materials. Where designed to be soldered at high temperatures, TI Pb-Free products are suitable for use in specified lead-free processes.

Pb-Free (RoHS Exempt): This component has a RoHS exemption for either 1) lead-based flip-chip solder bumps used between the die and package, or 2) lead-based die adhesive used between the die and leadframe. The component is otherwise considered Pb-Free (RoHS compatible) as defined above.

Green (RoHS & no Sb/Br): TI defines "Green" to mean Pb-Free (RoHS compatible), and free of Bromine (Br) and Antimony (Sb) based flame retardants (Br or Sb do not exceed 0.1% by weight in homogeneous material)

⁽³⁾ MSL, Peak Temp. -- The Moisture Sensitivity Level rating according to the JEDEC industry standard classifications, and peak solder temperature.

Important Information and Disclaimer: The information provided on this page represents TI's knowledge and belief as of the date that it is provided. TI bases its knowledge and belief on information provided by third parties, and makes no representation or warranty as to the accuracy of such information. Efforts are underway to better integrate information from third parties. TI has taken and continues to take reasonable steps to provide representative and accurate information but may not have conducted destructive testing or chemical analysis on incoming materials and chemicals. TI and TI suppliers consider certain information to be proprietary, and thus CAS numbers and other limited information may not be available for release.

In no event shall TI's liability arising out of such information exceed the total purchase price of the TI part(s) at issue in this document sold by TI to Customer on an annual basis.

OTHER QUALIFIED VERSIONS OF INA201-Q1 :

- Catalog: [INA201](#)

NOTE: Qualified Version Definitions:

- Catalog - TI's standard catalog product

TAPE AND REEL INFORMATION
REEL DIMENSIONS

TAPE DIMENSIONS

A0	Dimension designed to accommodate the component width
B0	Dimension designed to accommodate the component length
K0	Dimension designed to accommodate the component thickness
W	Overall width of the carrier tape
P1	Pitch between successive cavity centers

TAPE AND REEL INFORMATION

*All dimensions are nominal

Device	Package Type	Package Drawing	Pins	SPQ	Reel Diameter (mm)	Reel Width W1 (mm)	A0 (mm)	B0 (mm)	K0 (mm)	P1 (mm)	W (mm)	Pin1 Quadrant
INA201AQDGKRQ1	VSSOP	DGK	8	2500	330.0	12.4	5.3	3.4	1.4	8.0	12.0	Q1

TAPE AND REEL BOX DIMENSIONS



*All dimensions are nominal

Device	Package Type	Package Drawing	Pins	SPQ	Length (mm)	Width (mm)	Height (mm)
INA201AQDGKRQ1	VSSOP	DGK	8	2500	367.0	367.0	35.0

DGK (S-PDSO-G8)

PLASTIC SMALL-OUTLINE PACKAGE

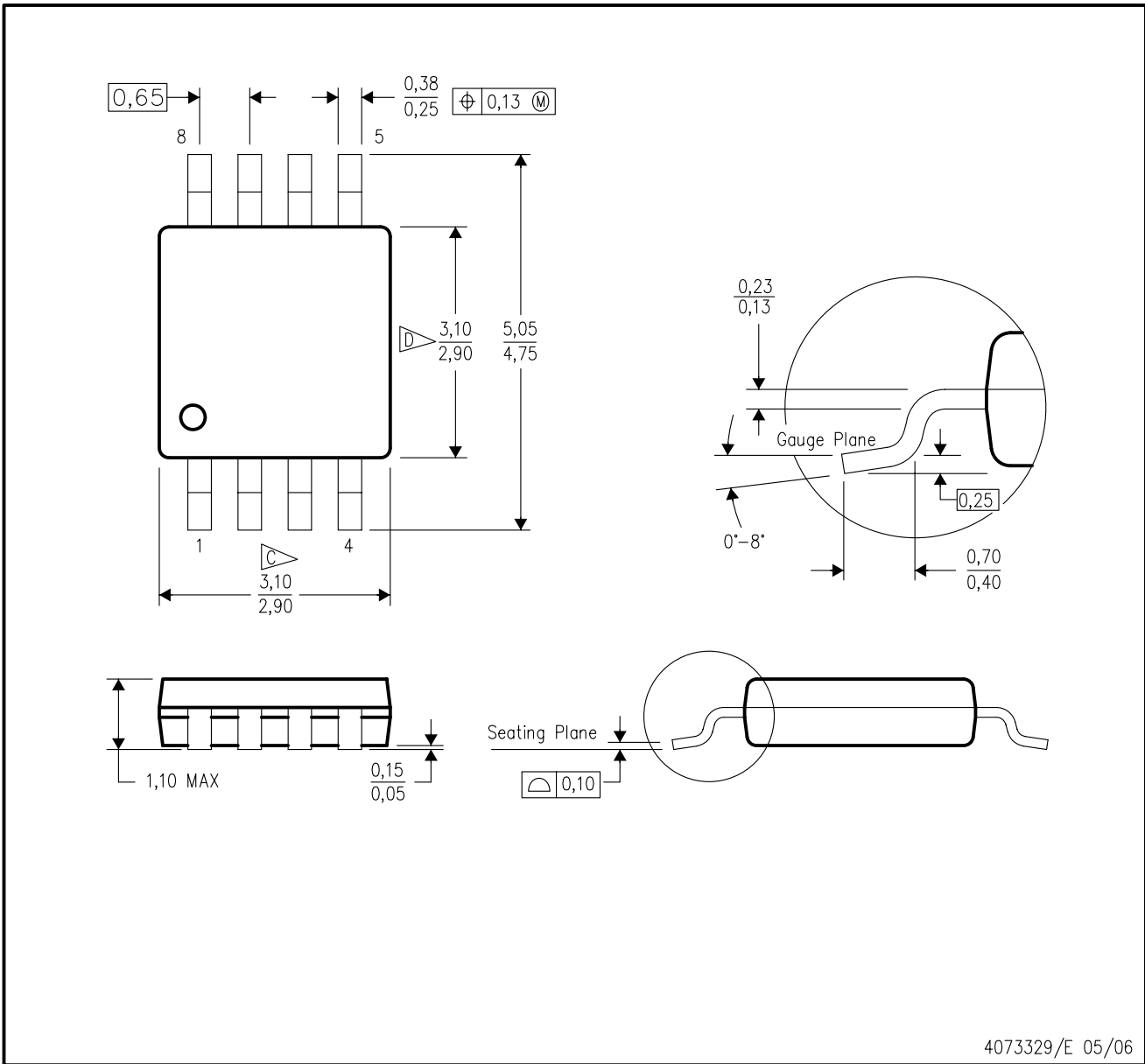

- NOTES:
- A. All linear dimensions are in millimeters.
 - B. This drawing is subject to change without notice.
 - ∇ C Body length does not include mold flash, protrusions, or gate burrs. Mold flash, protrusions, or gate burrs shall not exceed 0.15 per end.
 - ∇ D Body width does not include interlead flash. Interlead flash shall not exceed 0.50 per side.
 - E. Falls within JEDEC MO-187 variation AA, except interlead flash.

IMPORTANT NOTICE

Texas Instruments Incorporated and its subsidiaries (TI) reserve the right to make corrections, enhancements, improvements and other changes to its semiconductor products and services per JESD46C and to discontinue any product or service per JESD48B. Buyers should obtain the latest relevant information before placing orders and should verify that such information is current and complete. All semiconductor products (also referred to herein as "components") are sold subject to TI's terms and conditions of sale supplied at the time of order acknowledgment.

TI warrants performance of its components to the specifications applicable at the time of sale, in accordance with the warranty in TI's terms and conditions of sale of semiconductor products. Testing and other quality control techniques are used to the extent TI deems necessary to support this warranty. Except where mandated by applicable law, testing of all parameters of each component is not necessarily performed.

TI assumes no liability for applications assistance or the design of Buyers' products. Buyers are responsible for their products and applications using TI components. To minimize the risks associated with Buyers' products and applications, Buyers should provide adequate design and operating safeguards.

TI does not warrant or represent that any license, either express or implied, is granted under any patent right, copyright, mask work right, or other intellectual property right relating to any combination, machine, or process in which TI components or services are used. Information published by TI regarding third-party products or services does not constitute a license to use such products or services or a warranty or endorsement thereof. Use of such information may require a license from a third party under the patents or other intellectual property of the third party, or a license from TI under the patents or other intellectual property of TI.

Reproduction of significant portions of TI information in TI data books or data sheets is permissible only if reproduction is without alteration and is accompanied by all associated warranties, conditions, limitations, and notices. TI is not responsible or liable for such altered documentation. Information of third parties may be subject to additional restrictions.

Resale of TI components or services with statements different from or beyond the parameters stated by TI for that component or service voids all express and any implied warranties for the associated TI component or service and is an unfair and deceptive business practice. TI is not responsible or liable for any such statements.

Buyer acknowledges and agrees that it is solely responsible for compliance with all legal, regulatory and safety-related requirements concerning its products, and any use of TI components in its applications, notwithstanding any applications-related information or support that may be provided by TI. Buyer represents and agrees that it has all the necessary expertise to create and implement safeguards which anticipate dangerous consequences of failures, monitor failures and their consequences, lessen the likelihood of failures that might cause harm and take appropriate remedial actions. Buyer will fully indemnify TI and its representatives against any damages arising out of the use of any TI components in safety-critical applications.

In some cases, TI components may be promoted specifically to facilitate safety-related applications. With such components, TI's goal is to help enable customers to design and create their own end-product solutions that meet applicable functional safety standards and requirements. Nonetheless, such components are subject to these terms.

No TI components are authorized for use in FDA Class III (or similar life-critical medical equipment) unless authorized officers of the parties have executed a special agreement specifically governing such use.

Only those TI components which TI has specifically designated as military grade or "enhanced plastic" are designed and intended for use in military/aerospace applications or environments. Buyer acknowledges and agrees that any military or aerospace use of TI components which have **not** been so designated is solely at the Buyer's risk, and that Buyer is solely responsible for compliance with all legal and regulatory requirements in connection with such use.

TI has specifically designated certain components which meet ISO/TS16949 requirements, mainly for automotive use. Components which have not been so designated are neither designed nor intended for automotive use; and TI will not be responsible for any failure of such components to meet such requirements.

Products

Audio	www.ti.com/audio
Amplifiers	amplifier.ti.com
Data Converters	dataconverter.ti.com
DLP® Products	www.dlp.com
DSP	dsp.ti.com
Clocks and Timers	www.ti.com/clocks
Interface	interface.ti.com
Logic	logic.ti.com
Power Mgmt	power.ti.com
Microcontrollers	microcontroller.ti.com
RFID	www.ti-rfid.com
OMAP Mobile Processors	www.ti.com/omap
Wireless Connectivity	www.ti.com/wirelessconnectivity

Applications

Automotive and Transportation	www.ti.com/automotive
Communications and Telecom	www.ti.com/communications
Computers and Peripherals	www.ti.com/computers
Consumer Electronics	www.ti.com/consumer-apps
Energy and Lighting	www.ti.com/energy
Industrial	www.ti.com/industrial
Medical	www.ti.com/medical
Security	www.ti.com/security
Space, Avionics and Defense	www.ti.com/space-avionics-defense
Video and Imaging	www.ti.com/video

TI E2E Community e2e.ti.com