

## HIGH-SIDE MEASUREMENT CURRENT SHUNT MONITOR

### FEATURES

- **Qualification in Accordance With AEC-Q100<sup>(1)</sup>**
- **Qualified for Automotive Applications**
- **Customer-Specific Configuration Control Can Be Supported Along With Major-Change Approval**
- **ESD Protection Exceeds 2000 V Per MIL-STD-883, Method 3015; Exceeds 200 V Using Machine Model (C = 200 pF, R = 0)**
- **Complete Unipolar High-Side Current Measurement Circuit**
- **Wide Supply And Common-Mode Range**
  - INA139: 2.7 V to 40 V
  - INA169: 2.7 V to 60 V
- **Independent Supply and Input Common-Mode Voltages**
- **Single Resistor Gain Set**
- **Low Quiescent Current (60  $\mu$ A Typ)**
- **Wide Temperature Range:  $-40^{\circ}\text{C}$  to  $+125^{\circ}\text{C}$**
- **TSSOP-8 and SOT23-5 Packages**

### APPLICATIONS

- **Current Shunt Measurement:**
  - Automotive, Telephone, Computers
- **Portable And Battery-Backup Systems**
- **Battery Chargers**
- **Power Management**
- **Cell Phones**
- **Precision Current Source**

<sup>(1)</sup> Contact Texas Instruments for details. Q100 qualification data available on request.

### DESCRIPTION

The INA139 and INA169 are high-side, unipolar, current shunt monitors. Wide input common-mode voltage range, high-speed, low quiescent current, and tiny TSSOP-8 and SOT23 packaging enable use in a variety of applications.

Input common-mode and power-supply voltages are independent and can range from 2.7 V to 40 V for the INA139 and 2.7 V to 60 V for the INA169. Quiescent current is only 60  $\mu$ A, which permits connecting the power supply to either side of the current measurement shunt with minimal error.

The device converts a differential input voltage to a current output. This current is converted back to a voltage with an external load resistor that sets any gain from 1 to over 100. Although designed for current shunt measurement, the circuit invites creative applications in measurement and level shifting.

Both the INA139 and INA169 are available in TSSOP-8 and SOT23-5 and are specified for the  $-40^{\circ}\text{C}$  to  $+125^{\circ}\text{C}$  temperature range.

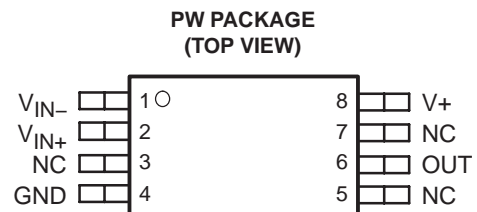

NC – No internal connection

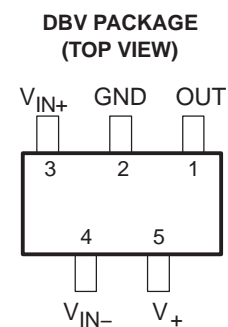

Please be aware that an important notice concerning availability, standard warranty, and use in critical applications of Texas Instruments semiconductor products and disclaimers thereto appears at the end of this data sheet.



These devices have limited built-in ESD protection. The leads should be shorted together or the device placed in conductive foam during storage or handling to prevent electrostatic damage to the MOS gates.

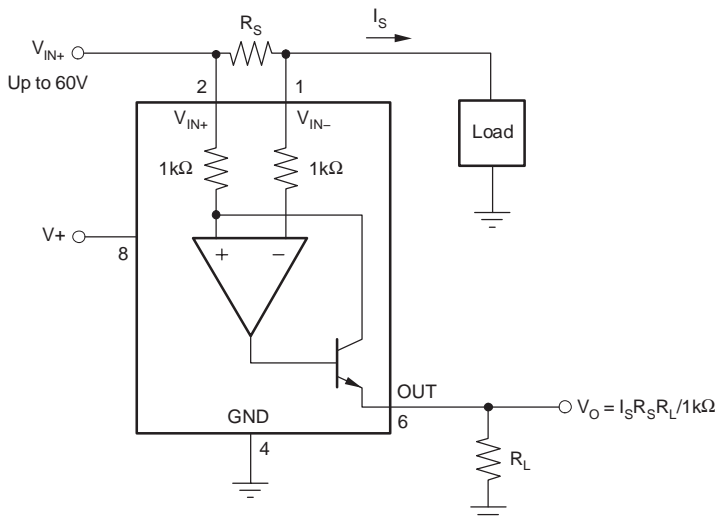

**ORDERING INFORMATION**

PRODUCT	PACKAGE-LEAD	PACKAGE DESIGNATOR(1)	SPECIFIED TEMPERATURE RANGE	PACKAGE MARKING	TRANSPORT MEDIA, QUANTITY
INA139QPWRQ1	TSSOP-8	PW	-40°C to +125°C	INA139	Tape and Reel, 2000
INA139NA/3KQ1	SOT23-5	DBV	-40°C to +125°C	39Q	Tape and Reel, 3000
INA169QPWRQ1	TSSOP-8	PW	-40°C to +125°C	INA169	Tape and Reel, 2000
INA169NA/3KQ1	SOT23-5	DBV	-40°C to +125°C	69Q	Tape and Reel, 3000

(1) For the most current specification and package information, see our web site at [www.ti.com](http://www.ti.com).

**ABSOLUTE MAXIMUM RATINGS**

over operating free-air temperature range unless otherwise noted(1)

Supply voltage, $V+$	INA139-Q1	-0.3 V to 60 V
	INA169-Q1	-0.3 V to 75 V
Analog inputs, $V_{IN+}$ , $V_{IN-}$ , Common mode	INA139-Q1	-0.3 V to 60 V
	INA169-Q1	-0.3 V to 75 V
Analog inputs, $(V_{IN+}) - (V_{IN-})$ , Differential		-40 V to 2 V
Analog output, out		-0.3 V to 40 V
Operating temperature		-55°C to 125°C
Storage temperature		-65°C to 150°C
Junction temperature		150°C
Thermal resistance, junction-to-ambient, $R_{\theta JA}$	PW package	150°C/W
	DBV package	200°C/W
Lead temperature (soldering, 10 seconds)		260°C

(1) Stresses beyond those listed under “absolute maximum ratings” may cause permanent damage to the device. These are stress ratings only, and functional operation of the device at these or any other conditions beyond those indicated under “recommended operating conditions” is not implied. Exposure to absolute-maximum-rated conditions for extended periods may affect device reliability.

**ELECTRICAL CHARACTERISTICS**
 $T_A = -40^\circ\text{C}$  to  $125^\circ\text{C}$ ,  $V_S = 5\text{ V}$ ,  $V_{IN+} = 12\text{ V}$ , and  $R_{OUT} = 25\text{ k}\Omega$  unless otherwise noted

PARAMETER	TEST CONDITIONS		MIN	TYP	MAX	UNIT
<b>INPUT</b>						
Full-scale sense voltage	$V_{SENSE} = V_{IN+} - V_{IN-}$			100	500	mV
Common-mode input range ( $V_{IN+}$ )		INA139	2.7		40	V
		INA169	2.7		60	
Common-mode rejection	$V_{IN+} = 2.7\text{ V to }40\text{ V}$ , $V_{SENSE} = 50\text{ mV}$	INA139	100	115		dB
	$V_{IN+} = 2.7\text{ V to }60\text{ V}$ , $V_{SENSE} = 50\text{ mV}$	INA169	100	120		
Offset voltage <sup>(1)</sup> RTI				$\pm 0.2$	$\pm 2$	mV
Offset voltage vs temperature				1		$\mu\text{V}/^\circ\text{C}$
Offset voltage vs power supply, $V_+$	$V_+ = 2.7\text{ V to }40\text{ V}$ , $V_{SENSE} = 50\text{ mV}$	INA139		0.5	10	$\mu\text{V}/\text{V}$
	$V_+ = 2.7\text{ V to }60\text{ V}$ , $V_{SENSE} = 50\text{ mV}$	INA169		0.1	10	
Input bias current				10		$\mu\text{A}$
<b>OUTPUT</b>						
Transconductance	$V_{SENSE} = 10\text{ mV} - 150\text{ mV}$		980	1000	1020	$\mu\text{A}/\text{V}$
Transconductance vs temperature	$V_{SENSE} = 100\text{ mV}$			10		$\text{nA}/^\circ\text{C}$
Nonlinearity error	$V_{SENSE} = 10\text{ mV to }150\text{ mV}$			$\pm 0.01\%$	$\pm 0.2\%$	
Total output error	$V_{SENSE} = 100\text{ mV}$			$\pm 0.5\%$	$\pm 2\%$	
Output impedance				1		$\text{G}\Omega$
				5		pF
Voltage output swing to power supply, $V_+$				( $V_+$ ) – 0.9	( $V_+$ ) – 1.2	V
Voltage output swing to common mode, $V_{CM}$				$V_{CM}$ – 0.6	$V_{CM}$ – 1	V
<b>FREQUENCY RESPONSE</b>						
Bandwidth		$R_{OUT} = 10\text{ k}\Omega$		440		kHz
		$R_{OUT} = 20\text{ k}\Omega$		220		
Settling time (0.1%)	5 V step	$R_{OUT} = 10\text{ k}\Omega$		2.5		$\mu\text{s}$
		$R_{OUT} = 20\text{ k}\Omega$		5		
<b>NOISE</b>						
Output-current noise density				20		$\text{pA}/\sqrt{\text{Hz}}$
Total output-current noise	BW = 100 kHz			7		nA RMS
<b>POWER SUPPLY</b>						
Operating range, $V_+$		INA139	2.7		40	V
		INA169	2.7		60	
Quiescent current	$V_{SENSE} = 0$ , $I_O = 0$			60	125	$\mu\text{A}$

<sup>(1)</sup> Defined as the amount of input voltage,  $V_{SENSE}$ , to drive the output to zero.

TYPICAL CHARACTERISTICS

Typical characteristics are at  $T_A = +25^\circ\text{C}$ ,  $V_+ = 5\text{ V}$ ,  $V_{IN+} = 12\text{ V}$ , and  $R_L = 125\text{ k}\Omega$ , unless otherwise noted.

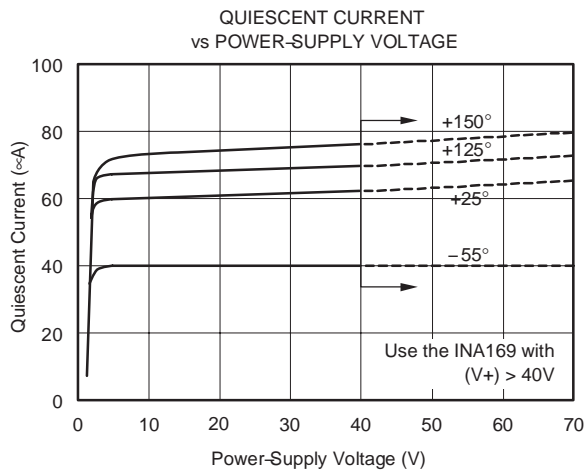
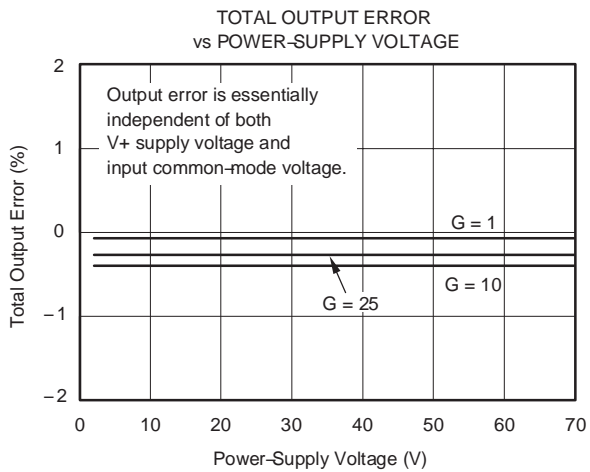
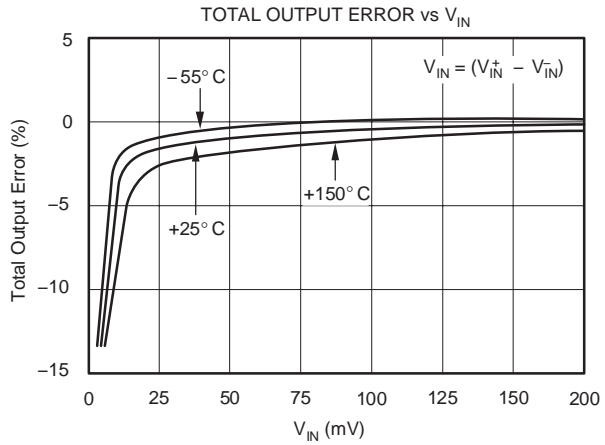
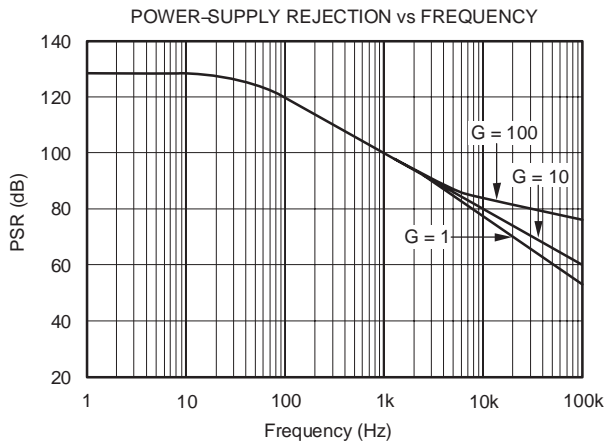
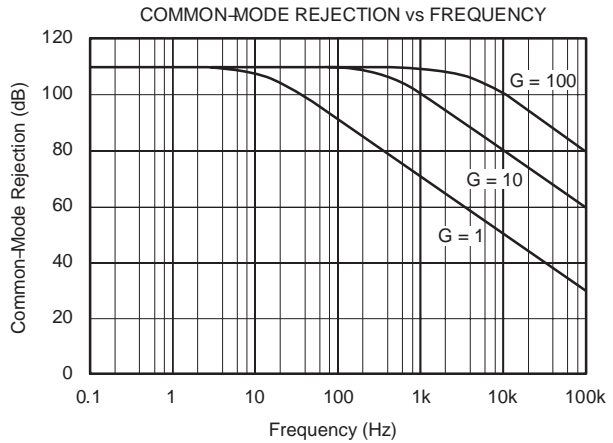
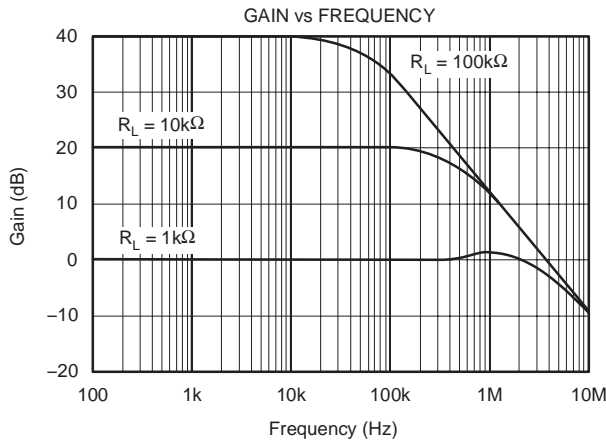

## TYPICAL CHARACTERISTICS (CONTINUED)

Typical characteristics are at  $T_A = +25^\circ\text{C}$ ,  $V_+ = 5\text{ V}$ ,  $V_{IN+} = 12\text{ V}$ , and  $R_L = 125\text{ k}\Omega$ , unless otherwise noted.

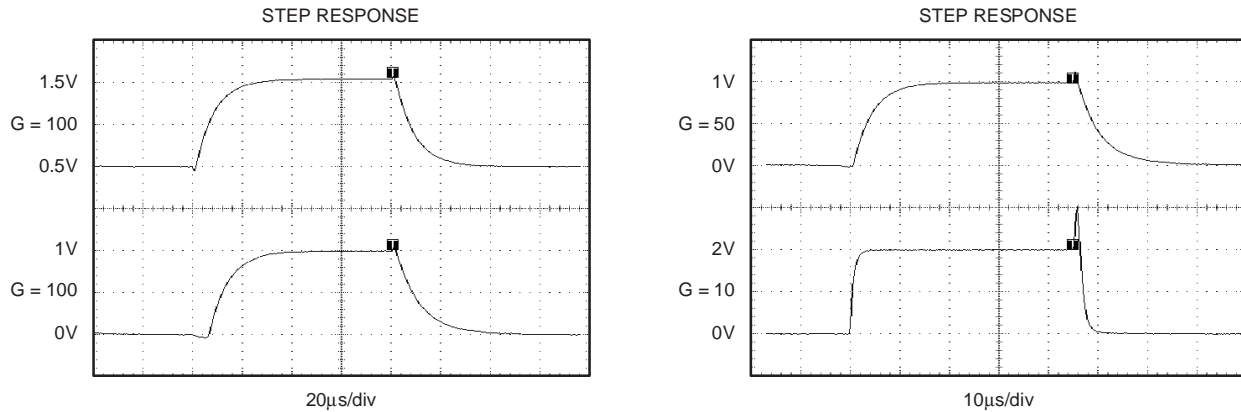

## APPLICATION INFORMATION

Figure 1 illustrates the basic circuit diagram for both the INA139 and INA169. Load current  $I_S$  is drawn from supply  $V_S$  through shunt resistor  $R_S$ . The voltage drop in shunt resistor  $V_S$  is forced across  $R_{G1}$  by the internal op amp, causing current to flow into the collector of Q1. External resistor  $R_L$  converts the output current to a voltage,  $V_{OUT}$ , at the OUT pin.

The transfer function for the INA139 is:

$$I_O = g_m (V_{IN+} - V_{IN-})$$

where  $g_m = 1000\ \mu\text{A/V}$ .

In the circuit of Figure 1, the input voltage ( $V_{IN+} - V_{IN-}$ ) is equal to  $I_S \times R_S$  and the output voltage ( $V_{OUT}$ ) is equal to  $I_O \times R_L$ . The transconductance ( $g_m$ ) of the INA139 is  $1000\ \mu\text{A/V}$ . The complete transfer function for the current measurement amplifier in this application is:

$$V_{OUT} = (I_S) (R_S) (1000\ \mu\text{A/V}) (R_L)$$

The maximum differential input voltage for accurate measurements is 0.5 V, which produces a 500- $\mu\text{A}$  output current. A differential input voltage of up to 2 V will not cause damage. Differential measurements (pins 3 and 4) must be unipolar with a more-positive voltage applied to pin 3. If a more-negative voltage is applied to pin 3, the output current,  $I_O$ , will be zero, but it will not cause damage.

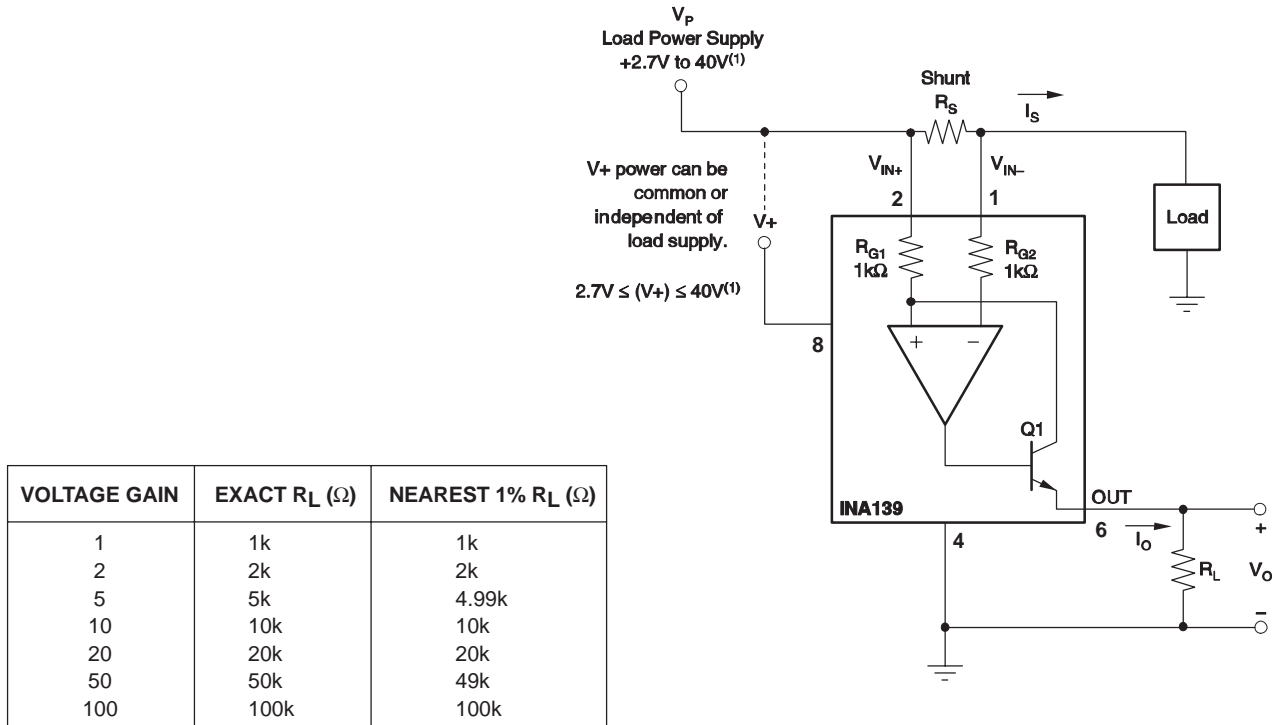

V+ power can be common or independent of load supply.  
 $2.7V \leq (V+) \leq 40V^{(1)}$

VOLTAGE GAIN	EXACT $R_L$ ( $\Omega$ )	NEAREST 1% $R_L$ ( $\Omega$ )
1	1k	1k
2	2k	2k
5	5k	4.99k
10	10k	10k
20	20k	20k
50	50k	49k
100	100k	100k

NOTE: (1) Maximum  $V_p$  and  $V+$  voltage is 60V with the INA169.

Figure 1. Basic Circuit Connections

**BASIC CONNECTION**

Figure 1 shows the basic connection of the INA139. The input pins,  $V_{IN+}$  and  $V_{IN-}$ , should be connected as closely as possible to the shunt resistor to minimize any resistance in series with the shunt resistance. The output resistor,  $R_L$ , is shown connected between pin 1 and ground. Best accuracy is achieved with the output voltage measured directly across  $R_L$ . This is especially important in high-current systems where load current could flow in the ground connections, affecting the measurement accuracy. No power-supply bypass capacitors are required for stability of the INA139. However, applications with noisy or high-impedance power supplies may require decoupling capacitors to reject power-supply noise; connect bypass capacitors close to the device pins.

**POWER SUPPLIES**

The input circuitry of the INA139 can accurately measure beyond its power-supply voltage,  $V+$ . For example, the  $V+$  power supply can be 5 V, whereas the load power supply voltage is up to +36 V (or +60 V with the INA169). However, the output voltage range of the OUT terminal is limited by the lesser of the two voltages (see the *Output Voltage Range* section).

**SELECTING  $R_S$  AND  $R_L$**

The value chosen for the shunt resistor,  $R_S$ , depends on the application and is a compromise between small-signal accuracy and maximum permissible voltage loss in the measurement line. High values of  $R_S$  provide better accuracy at lower currents by minimizing the effects of offset, while low values of  $R_S$  minimize voltage loss in the supply line. For most applications, best performance is attained with an  $R_S$  value that provides a full-scale shunt voltage range of 50 mV to 100 mV. Maximum input voltage for accurate measurements is 500 mV.

$R_L$  is chosen to provide the desired full-scale output voltage. The output impedance of the INA139 OUT terminal is very high which permits using values of  $R_L$  up to 100 k $\Omega$  with excellent accuracy. The input impedance of any additional circuitry at the output should be much higher than the value of  $R_L$  to avoid degrading accuracy.

Some Analog-to-Digital (A/D) converters have input impedances that will significantly affect measurement gain. The input impedance of the A/D converter can be included as part of the effective  $R_L$  if its input can be modeled as a resistor to ground. Alternatively, an op amp can be used to buffer the A/D converter input as shown in Figure 2. See Figure 1 for recommended values of  $R_L$ .

## OUTPUT VOLTAGE RANGE

The output of the INA139 is a current, which is converted to a voltage by the load resistor,  $R_L$ . The output current remains accurate within the compliance voltage range of the output circuitry. The shunt voltage and the input common-mode and power-supply voltages limit the maximum possible output swing. The maximum output voltage compliance is limited by the lower of the two equations below:

$$V_{OUT\ MAX} = (V+) - 0.7\ V - (V_{IN+} - V_{IN-})$$

or

$$V_{OUT\ MAX} = V_{IN-} - 0.5\ V$$

(whichever is lower)

## BANDWIDTH

Measurement bandwidth is affected by the value of the load resistor,  $R_L$ . High gain produced by high values of  $R_L$  yields a narrower measurement bandwidth (see the *Typical Characteristics* section). For widest possible bandwidth, keep the capacitive load on the output to a minimum.

If bandwidth limiting (filtering) is desired, a capacitor can be added to the output (as shown in Figure 3) which will not cause instability.

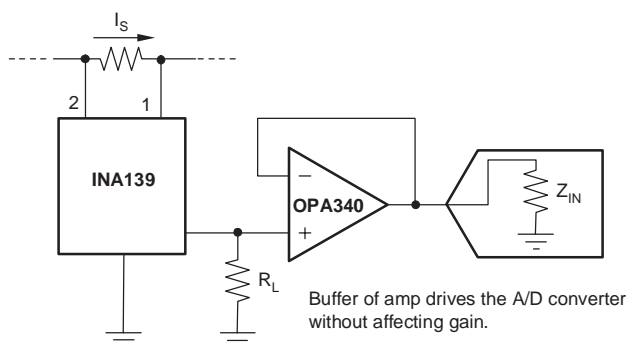

Figure 2. Buffering Output to Drive the A/D Converter

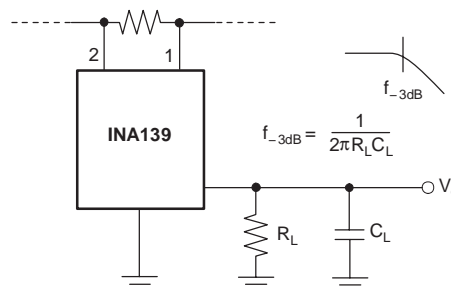

Figure 3. Output Filter

## APPLICATIONS

The INA139 is designed for current shunt measurement circuits, as shown in Figure 1, but its basic function is useful in a wide range of circuitry. A few ideas are illustrated in Figure 4 through Figure 7.

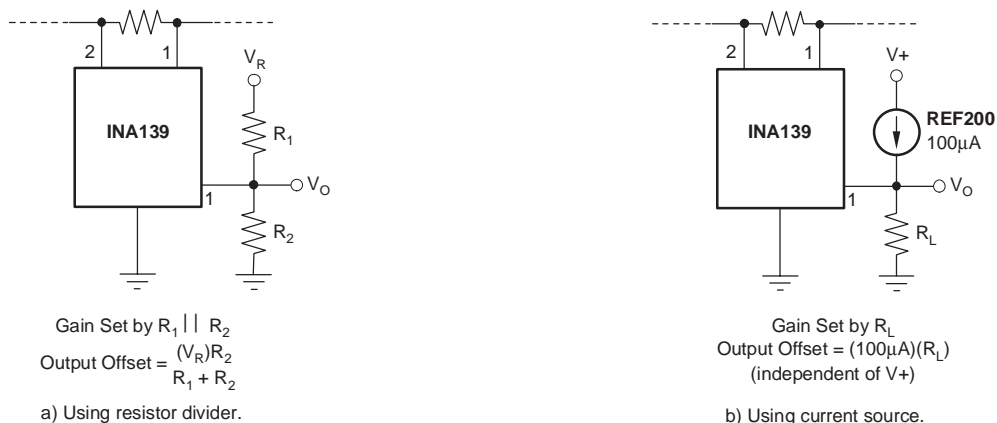

Figure 4. Offsetting the Output Voltage

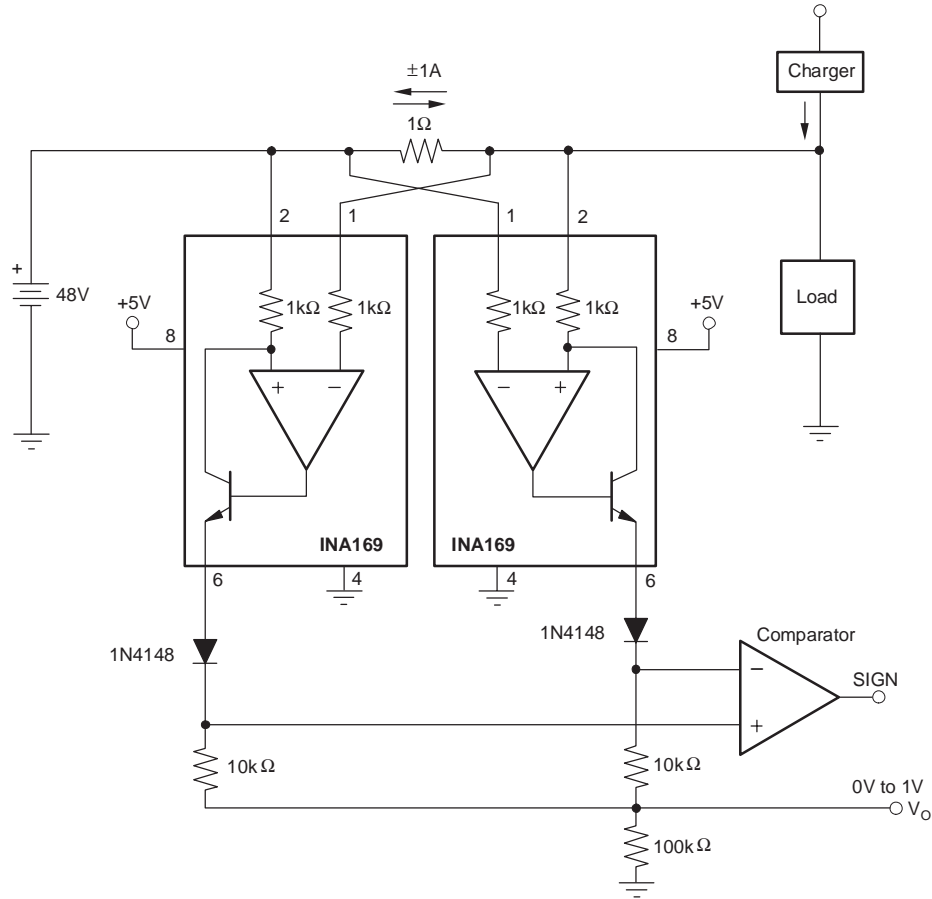
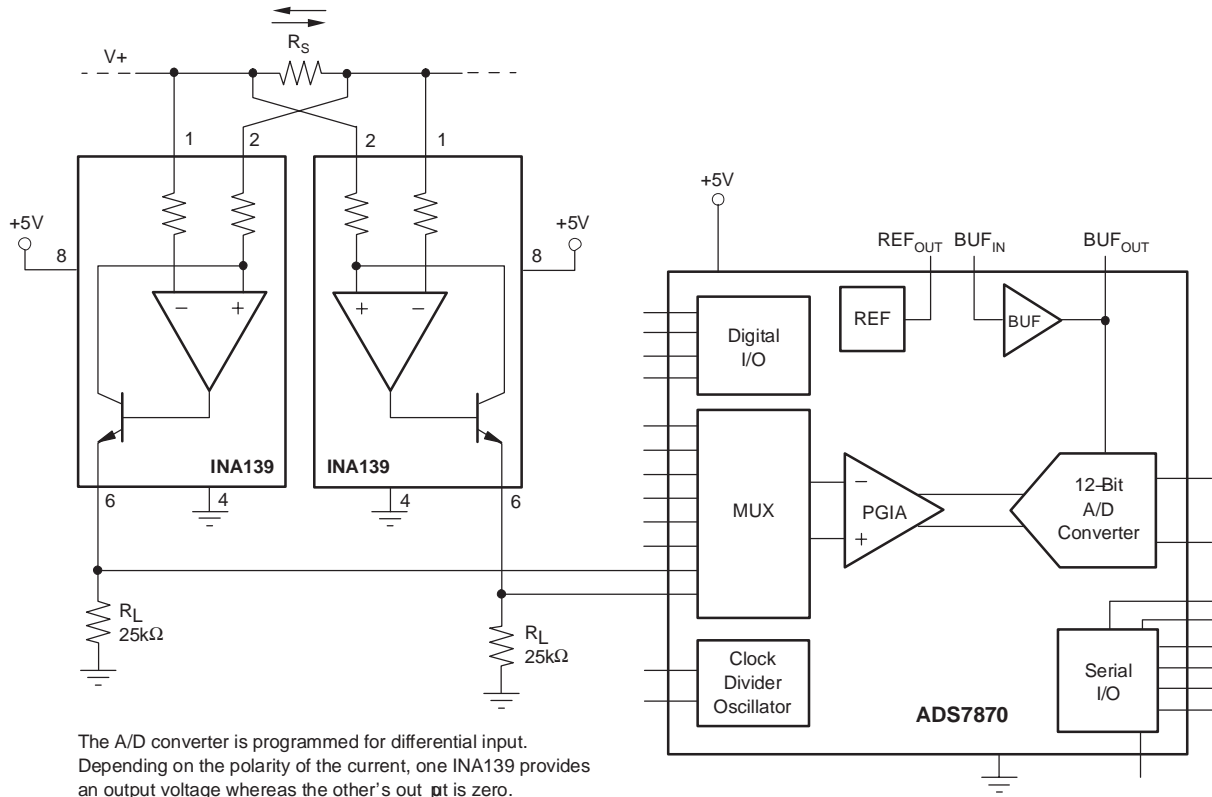

Figure 5. Bipolar Current Measurement





**Figure 6. Bipolar Current Measurement Using Differential Input of A/D Converter**

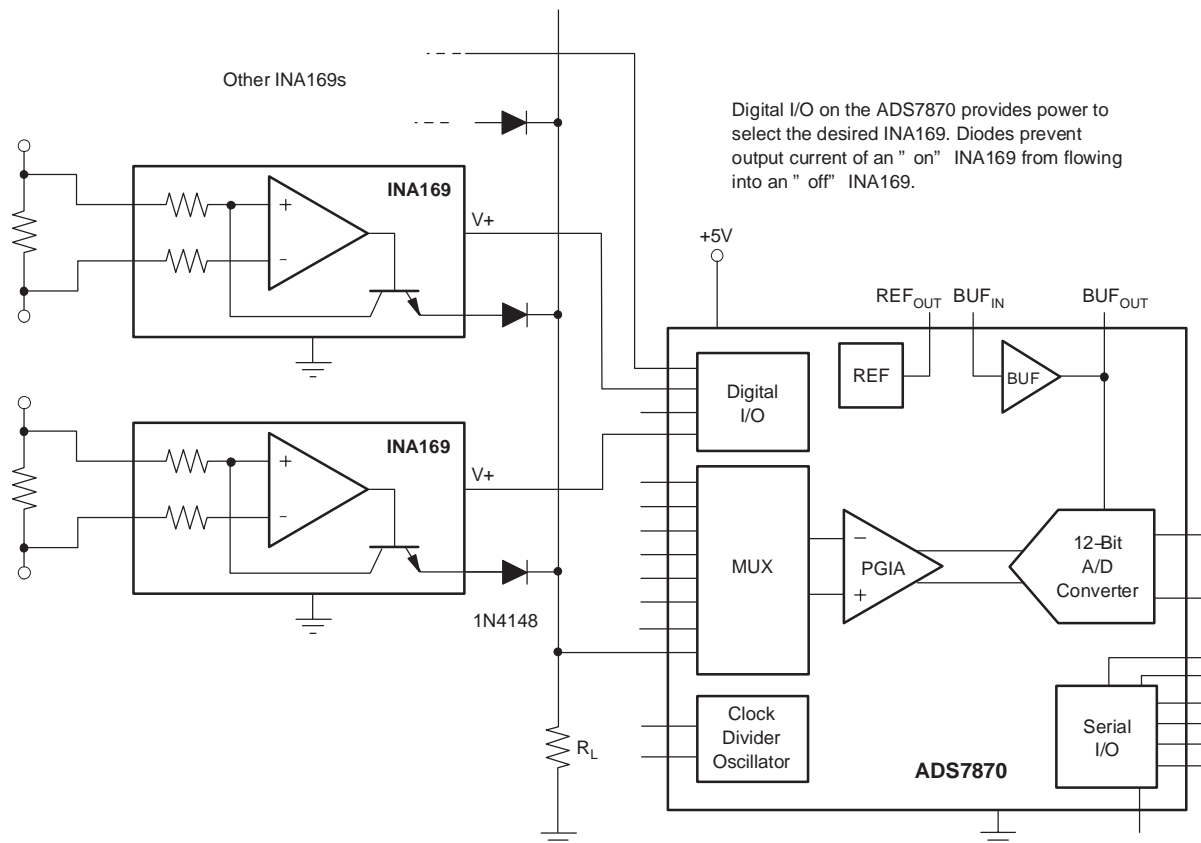

Figure 7. Multiplexed Measurement Using Logic Signal for Power

PW (R-PDSO-G\*\*)

PLASTIC SMALL-OUTLINE PACKAGE

14 PINS SHOWN



4040064/F 01/97

- NOTES: A. All linear dimensions are in millimeters.  
 B. This drawing is subject to change without notice.  
 C. Body dimensions do not include mold flash or protrusion not to exceed 0,15.  
 D. Falls within JEDEC MO-153

## IMPORTANT NOTICE

Texas Instruments Incorporated and its subsidiaries (TI) reserve the right to make corrections, modifications, enhancements, improvements, and other changes to its products and services at any time and to discontinue any product or service without notice. Customers should obtain the latest relevant information before placing orders and should verify that such information is current and complete. All products are sold subject to TI's terms and conditions of sale supplied at the time of order acknowledgment.

TI warrants performance of its hardware products to the specifications applicable at the time of sale in accordance with TI's standard warranty. Testing and other quality control techniques are used to the extent TI deems necessary to support this warranty. Except where mandated by government requirements, testing of all parameters of each product is not necessarily performed.

TI assumes no liability for applications assistance or customer product design. Customers are responsible for their products and applications using TI components. To minimize the risks associated with customer products and applications, customers should provide adequate design and operating safeguards.

TI does not warrant or represent that any license, either express or implied, is granted under any TI patent right, copyright, mask work right, or other TI intellectual property right relating to any combination, machine, or process in which TI products or services are used. Information published by TI regarding third-party products or services does not constitute a license from TI to use such products or services or a warranty or endorsement thereof. Use of such information may require a license from a third party under the patents or other intellectual property of the third party, or a license from TI under the patents or other intellectual property of TI.

Reproduction of information in TI data books or data sheets is permissible only if reproduction is without alteration and is accompanied by all associated warranties, conditions, limitations, and notices. Reproduction of this information with alteration is an unfair and deceptive business practice. TI is not responsible or liable for such altered documentation.

Resale of TI products or services with statements different from or beyond the parameters stated by TI for that product or service voids all express and any implied warranties for the associated TI product or service and is an unfair and deceptive business practice. TI is not responsible or liable for any such statements.

Following are URLs where you can obtain information on other Texas Instruments products and application solutions:

<b>Products</b>		<b>Applications</b>	
Amplifiers	<a href="http://amplifier.ti.com">amplifier.ti.com</a>	Audio	<a href="http://www.ti.com/audio">www.ti.com/audio</a>
Data Converters	<a href="http://dataconverter.ti.com">dataconverter.ti.com</a>	Automotive	<a href="http://www.ti.com/automotive">www.ti.com/automotive</a>
DSP	<a href="http://dsp.ti.com">dsp.ti.com</a>	Broadband	<a href="http://www.ti.com/broadband">www.ti.com/broadband</a>
Interface	<a href="http://interface.ti.com">interface.ti.com</a>	Digital Control	<a href="http://www.ti.com/digitalcontrol">www.ti.com/digitalcontrol</a>
Logic	<a href="http://logic.ti.com">logic.ti.com</a>	Military	<a href="http://www.ti.com/military">www.ti.com/military</a>
Power Mgmt	<a href="http://power.ti.com">power.ti.com</a>	Optical Networking	<a href="http://www.ti.com/opticalnetwork">www.ti.com/opticalnetwork</a>
Microcontrollers	<a href="http://microcontroller.ti.com">microcontroller.ti.com</a>	Security	<a href="http://www.ti.com/security">www.ti.com/security</a>
		Telephony	<a href="http://www.ti.com/telephony">www.ti.com/telephony</a>
		Video & Imaging	<a href="http://www.ti.com/video">www.ti.com/video</a>
		Wireless	<a href="http://www.ti.com/wireless">www.ti.com/wireless</a>

Mailing Address: Texas Instruments  
Post Office Box 655303 Dallas, Texas 75265