

# Control integrated Power System (CIPOS™)

IKCS22F60F2A

IKCS22F60F2C

<http://www.infineon.com/cipos>

Power Management & Drives



---

<b>Revision History:</b>	<b>2009-07</b>	Rev.2.1
Previous Version:	2	
Page	Subjects (major changes since last revision)	
4	Added UL certification	
10	Change $V_{IT,HYS}$	
11	Revised energy units	

**Authors: W. Frank, H. Rettinger**

**Edition 2008-09**

**Published by  
Infineon Technologies AG  
85579 Neubiberg, Germany**

**© Infineon Technologies AG 7/28/09.**

**All Rights Reserved.**

**Attention please!**

The information given in this data sheet shall in no event be regarded as a guarantee of conditions or characteristics ("Beschaffheitsgarantie"). With respect to any examples or hints given herein, any typical values stated herein and/or any information regarding the application of the device, Infineon Technologies hereby disclaims any and all warranties and liabilities of any kind, including without limitation warranties of non-infringement of intellectual property rights of any third party.

#### **Information**

For further information on technology, delivery terms and conditions and prices please contact your nearest Infineon Technologies Office or representatives (<http://www.infineon.com>).

#### **Warnings**

Due to technical requirements components may contain dangerous substances. For information on the types in question please contact your nearest Infineon Technologies Office or representatives.

Infineon Technologies Components may only be used in life-support devices or systems with the express written approval of Infineon Technologies, if a failure of such components can reasonably be expected to cause the failure of that life-support device or system, or to affect the safety or effectiveness of that device or system. Life support devices or systems are intended to be implanted in the human body, or to support and/or maintain and sustain and/or protect human life. If they fail, it is reasonable to assume that the health of the user or other persons may be endangered.

**TRENCHSTOP®** is a registered trademark of Infineon Technologies AG.

**CIPOS™, CoolMOS™, CoolSET™, DuoPack™ and thinQ!™** are trademarks of Infineon Technologies AG.

## Table of Contents

<b>CIPOS™ Control integrated Power System .....</b>	<b>4</b>
<b>Features .....</b>	<b>4</b>
<b>Target Applications .....</b>	<b>4</b>
<b>Description .....</b>	<b>4</b>
<b>System Configuration .....</b>	<b>4</b>
<b>Internal Electrical Schematic .....</b>	<b>5</b>
<b>Pin Assignment.....</b>	<b>6</b>
<b>Pin Description .....</b>	<b>6</b>
/HIN1,2,3 and /LIN1,2,3 (Low side and high side control pins, Pin 15 - 20) .....	6
/FLT-TEMP (temperature NTC, Pin 24) .....	7
ITRIP (Over-current detection function, Pin 21) .....	7
VDD, VSS (control side supply and reference, Pin 22, 23) .....	7
VB1,2,3 and VS1,2,3 (High side supplies, Pin 1, 2, 4, 5, 7, 8) .....	7
VRU, VRV, VRW (low side emitter, Pin 12, 13, 14) .....	7
V+ (positive bus input voltage, Pin 10) .....	7
<b>Absolute Maximum Ratings.....</b>	<b>8</b>
<b>Module Section .....</b>	<b>8</b>
<b>IGBT and Diode Section.....</b>	<b>8</b>
<b>Control Section .....</b>	<b>9</b>
<b>Recommended Operation Conditions .....</b>	<b>9</b>
<b>Static Parameters.....</b>	<b>10</b>
<b>Dynamic Parameters .....</b>	<b>12</b>
<b>Integrated Components .....</b>	<b>13</b>
<b>Typical Application.....</b>	<b>13</b>
<b>Characteristics .....</b>	<b>14</b>
<b>Test Circuits and Parameter Definition .....</b>	<b>16</b>
<b>Package Outline IKCS22F60F2A .....</b>	<b>18</b>
<b>Package Outline IKCS22F60F2C .....</b>	<b>19</b>

# CIPOS™ Control integrated Power System

*Single In-Line Intelligent Power Module*

*3Φ-bridge 600V / 22A @ 25°C*

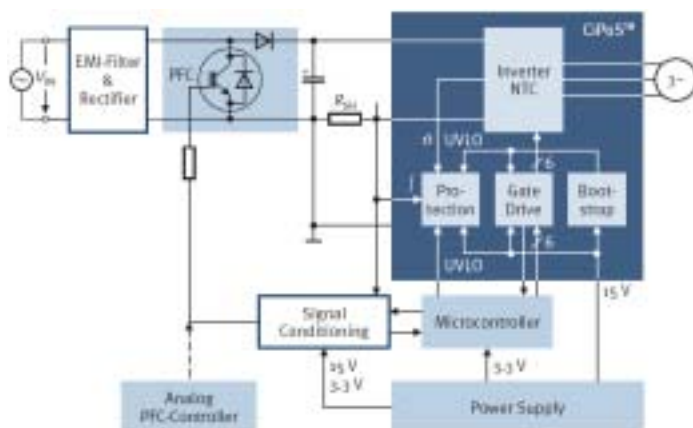


## Features

- DCB isolated Single In-Line molded module
- FAULT signal
- TrenchStop® IGBTs with lowest  $V_{CE(sat)}$
- Optimal adapted antiparallel diode for low EMI
- Integrated bootstrap diode and capacitor
- Rugged SOI gate driver technology with stability against transient and negative voltage
- Fully compliant to 3.3V and 5V microcontrollers
- Temperature sense
- Undervoltage lockout at all channels
- Matched propagation delay for all channels
- Low side emitter pins accessible for all phase current monitoring (open emitter)
- Cross-conduction prevention
- Lead-free terminal plating; RoHS compliant
- Qualified according to JEDEC<sup>1</sup> (high temperature stress tests for 1000h) for target applications

## Target Applications

- Washing machines
- Consumer Fans and Consumer Compressors



## Description

The CIPOS™ module family offers the chance for integrating various power and control components to increase reliability, optimize PCB size and system costs.

This SIL-IPM is designed to control AC motors in variable speed drives for applications like air conditioning, compressors and washing machines. The package concept is specially adapted to power applications, which need extremely good thermal conduction and electrical isolation, but also EMI-save control and overload protection. The features of Infineon TrenchStop® IGBTs and antiparallel diodes are combined with a new optimized Infineon SOI gate driver for excellent electrical performance. The product provides a FAULT signal, which is significantly simplifying the system.

## System Configuration

- 3 halfbridges with TrenchStop® IGBT & FW-diodes
- 3Φ SOI gate driver
- Bootstrap diodes for high side supply
- Integrated 100nF bootstrap capacitance
- Temperature sensor, passive components for adaptations
- Isolated heatsink
- Creepage distance typ. 3.2mm

## Certification

UL 1577 (UL file E314539)

<sup>1</sup> J-STD-020 and JESD-022

### Internal Electrical Schematic

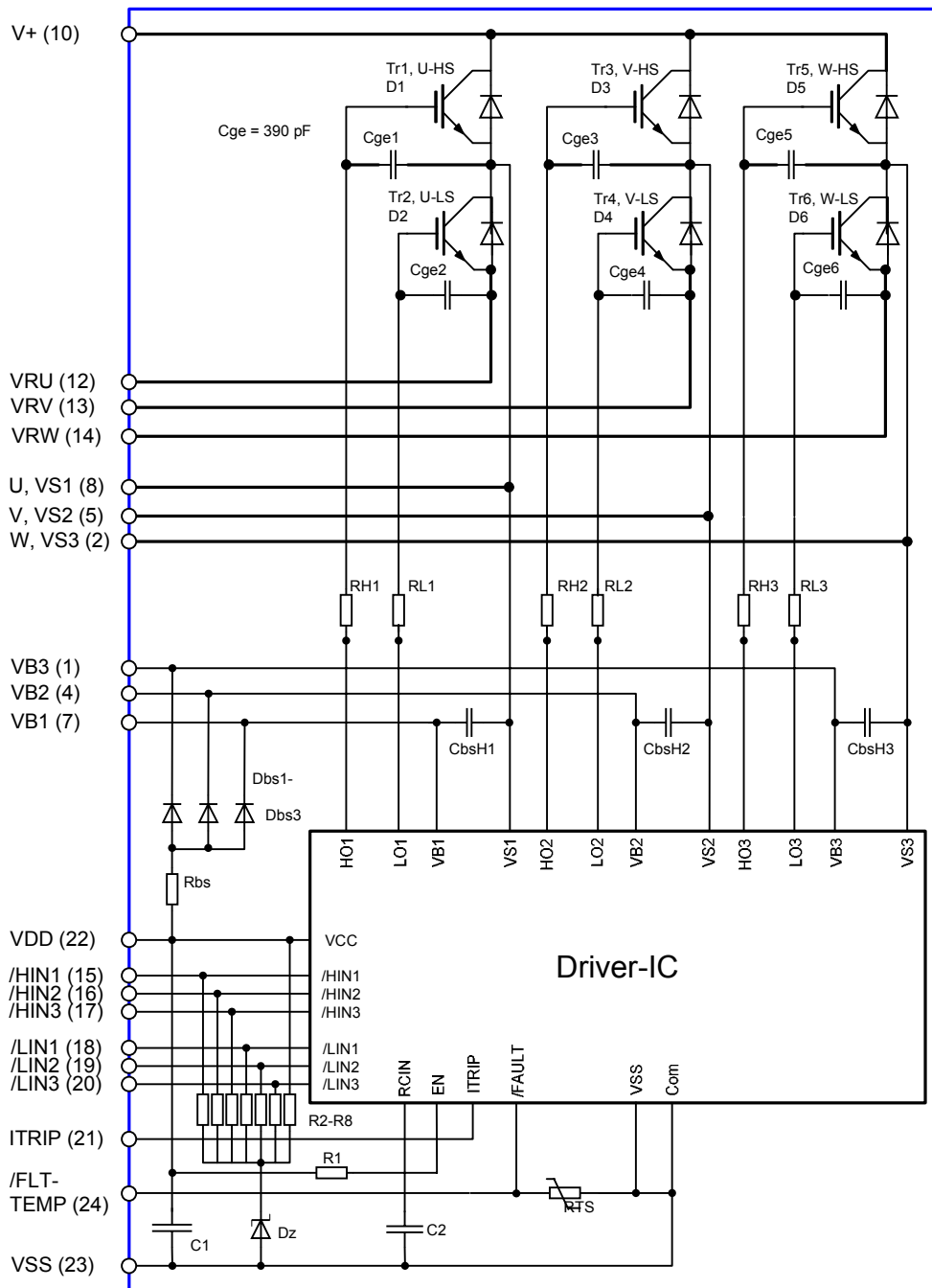


Figure 1: Internal Schematic

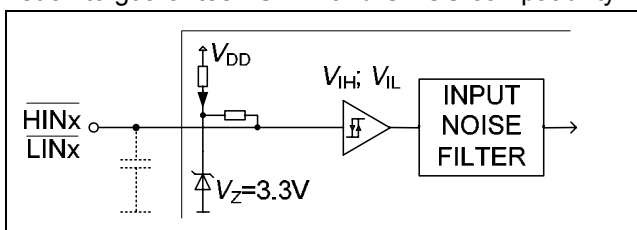
## Pin Assignment

Pin Number	Pin Name	Pin Description
1	VB3	high side floating IC supply voltage
2	W,VS3	motor output W, high side floating IC supply offset voltage
3	n.a.	None
4	VB2	high side floating IC supply voltage
5	V,VS2	motor output V, high side floating IC supply offset voltage
6	n.a.	None
7	VB1	high side floating IC supply voltage
8	U,VS1	motor output U, high side floating IC supply offset voltage
9	n.a.	None
10	V+	positive bus input voltage
11	n.a.	None
12	VRU	low side emitter
13	VRV	low side emitter
14	VRW	low side emitter
15	/HIN1	input gate driver high side 1/U
16	/HIN2	input gate driver high side 2/V
17	/HIN3	input gate driver high side 3/W
18	/LIN1	input gate driver low side 1/U
19	/LIN2	input gate driver low side 2/V
20	/LIN3	input gate driver low side 3/W
21	ITRIP	input overcurrent shutdown
22	VDD	module control supply
23	VSS	module negative supply
24	/FLT-TEMP	Fault indication and temperature monitoring

## Pin Description

### /HIN1,2,3 and /LIN1,2,3 (Low side and high side control pins, Pin 15 - 20)

These pins are active low and they are responsible for the control of the integrated IGBT. The Schmitt-trigger input threshold of them are such to guarantee LSTTL and CMOS compatibility



**Figure 2: Input pin structure**

down to 3.3V controller outputs. The maximum voltage at these pins is 6V and therefore fully compliant to 3.3V-microcontrollers. Pull-up resistor of about 75 kΩ is internally provided to pre-bias inputs during supply start-up and a zener clamp is provided for pin protection purposes. Input schmitt-trigger and noise filter provide beneficial noise rejection to short input pulses.

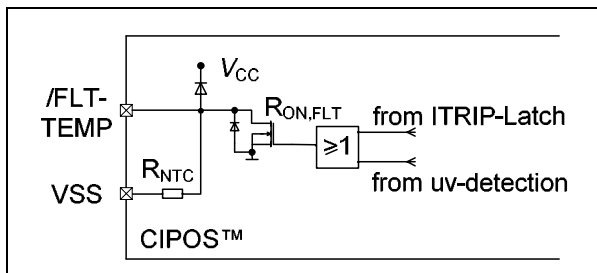
It is recommended for proper work of CIPOS™ not to provide an input pulse-width and PWM deadtimes lower than 1μs.

The integrated gate drive provides additionally a shoot through prevention capability which avoids the simultaneous on-state of two gate drivers of the same leg (i.e. HO1 and LO1, HO2 and LO2, HO3 and LO3).

A minimum dead time insertion of typ 380ns is also provided, in order to reduce cross-conduction of the external power switches.

### /FLT-TEMP (temperature NTC, Pin 24)

The TEMP terminal provides direct access to the NTC, which is referenced to VSS. An external pull-up resistor connected to +5V ensures, that the resulting voltage can be directly connected to the microcontroller.



**Figure 3: Internal Circuit at pin TEMP**

The same pin indicates a module failure in case of under voltage at pin VDD or in case of triggered over current detection at ITRIP. A pull-up resistor is externally required to bias the NTC. No temperature information is available during fault.

### ITRIP (Over-current detection function, Pin 21)

CIPOS™ provides an over-current detection function by connecting the ITRIP input with the motor current feedback. The ITRIP comparator threshold (typ 0.46V) is referenced to VSS ground. A input noise filter (typ:  $t_{TRIPMIN} = 220ns$ ) prevents the driver to detect false over-current events.

Over-current detection generates a hard shut down of all outputs of the gate driver after the shutdown propagation delay of typically 900ns.

The fault-clear time is set to typically to 4.7ms.

### VDD, VSS (control side supply and reference, Pin 22, 23)

VDD is the low side supply and it provides power both to input logic and to low side output power stage. Input logic is referenced to VSS ground as well as the under-voltage detection circuit.

The under-voltage circuit enables the device to operate at power on when a supply voltage of at least a typical voltage of  $V_{DDUV+} = 12.1 V$  is at least present.

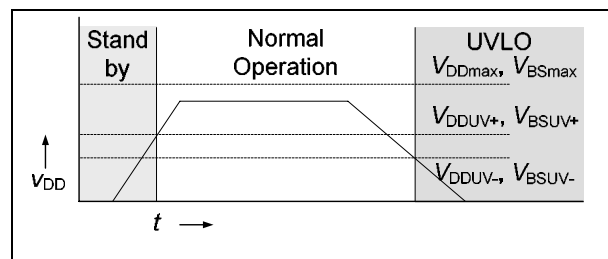
The IC shuts down all the gate drivers power outputs, when the VCC supply voltage is below

$V_{DDUV-} = 10.4 V$ . This prevents the external power switches from critically low gate voltage levels during on-state and therefore from excessive power dissipation.

### VB1,2,3 and VS1,2,3 (High side supplies, Pin 1, 2, 4, 5, 7, 8)

VB to VS is the high side supply voltage. The high side circuit can float with respect to VSS following the external high side power device emitter/source voltage.

Due to the low power consumption, the floating driver stage is supplied by an integrated bootstrap circuit connected to VDD. This includes also integrated bootstrap capacitors of 100 nF at each floating supply, which are located very close to the



**Figure 4: Input filter timing diagram**

gate drive circuit.

The under-voltage detection operates with a rising supply threshold of typical  $V_{BSUV+} = 12.1 V$  and a falling threshold of  $V_{DDUV-} = 10.4 V$  according to Figure 4.

VS1,2,3 provide a high robustness against negative voltage in respect of VSS of -50 V. This ensures very stable designs even under rough conditions.

### VRU, VRV, VRW (low side emitter, Pin 12, 13, 14)

The low side emitters are available for current measurements of each phase leg. It is recommended to keep the connection to pin VSS as short as possible in order to avoid unnecessary inductive voltage drops.

### V+ (positive bus input voltage, Pin 10)

The high side IGBT are connected to the bus voltage. It is recommended, that the bus voltage does not exceed 500 V.

## Absolute Maximum Ratings

( $T_c = 25^\circ\text{C}$ , if not stated otherwise)

### Module Section

Description	Condition	Symbol	Value		Unit
			Min	max	
Storage temperature range		$T_{\text{stg}}$	-40	125	$^\circ\text{C}$
Operating temperature control PCB <sup>1</sup>		$T_{\text{PCB}}$	-	125	$^\circ\text{C}$
Solder temperature	Wave soldering, 1.6mm (0.063in.) from case for 10s	$T_{\text{sol}}$	-	260	$^\circ\text{C}$
Insulation test voltage	RMS, $f=50\text{Hz}$ , $t = 1\text{min}$	$V_{\text{ISOL}}$	2500	-	V
Mounting torque	M3 screw and washer	$M_{\text{S}}$	-	0.6	Nm
Mounting pressure on surface	Package flat on mounting surface	$N_{\text{MC}}$	-	150	N/mm <sup>2</sup>
Creepage distance		$d_{\text{S}}$	3.1	-	mm
Max. peak power of bootstrap resistor	$t_{\text{p}} = 100\mu\text{s}$ $T_c = 100^\circ\text{C}$	$P_{\text{BRpeak}}$		90	W

### IGBT and Diode Section

Description	Condition	Symbol	Value		Unit
			min	max	
Max. Blocking Voltage		$V_{\text{CES}}$	600	-	V
DC output current	$T_c = 25^\circ\text{C}, T_{\text{vj}} < 150^\circ\text{C}$ $T_c = 80^\circ\text{C}, T_{\text{vj}} < 150^\circ\text{C}$	$I_{\text{u}}, I_{\text{v}}, I_{\text{w}}$	-22 -14	22 14	A
Repetitive peak collector current	$T_{\text{p}}$ limited by $T_{\text{vjmax}}$	$I_{\text{u}}, I_{\text{v}}, I_{\text{w}}$	-45	45	A
Short circuit withstand time <sup>2</sup>	$V_{\text{DD}}=15\text{V}$ , $V_{\text{DC}}= 400\text{V}$ , $T_{\text{vj}} = 150^\circ\text{C}$	$t_{\text{sc}}$	-	5	$\mu\text{s}$
Power dissipation per IGBT	$T_c = 25^\circ\text{C}$	$P_{\text{tot}}$	-	59	W
Operating junction temperature range	IGBT Diode	$T_{\text{vjI}}$ $T_{\text{vjD}}$	-40 -40	150 150	$^\circ\text{C}$

<sup>1</sup> Monitored by pin 24

<sup>2</sup> Allowed number of short circuits: <1000; time between short circuits: >1s.



Description	Condition	Symbol	Value			Unit
			min	typ	max	
Single IGBT thermal resistance, junction-case		$R_{thJC}$	-	-	2.1	K/W
Single diode thermal resistance, junction-case		$R_{thJCD}$	-	-	2.7	

### Control Section

Description	Condition	Symbol	Value		Unit
			min	max	
Module supply voltage		$V_{DD}$	-1	20	V
High side floating supply voltage (VB vs. VS)		$V_{BS}$	-1	20	
High side floating IC supply offset voltage	$t_p < 500ns$	$V_{S1,2,3}$	VDD-VBS-6 VDD-VBS-50	600	
ITRIP input voltage		$V_{IN,ITRIP}$	-1	10	
/FLT-TEMP Input voltage		$V_{IN,FLT}$	-1	20	
/HIN, /LIN Input voltage	$V_{IN} = \text{float}$	$V_{IN}$	-	5.5	
/FLT-TEMP Input current		$I_{IN,FLT}$	-	5	mA
Operating junction temperature <sup>1</sup>		$T_{J,IC}$	-	125	°C
Max. switching frequency		$f_{PWM}$	-	20	kHz

### Recommended Operation Conditions

All voltages are absolute voltages referenced to  $V_{SS}$  -Potential unless otherwise specified.

Description	Symbol	Value		Unit
		min	max	
High side floating supply offset voltage	$V_S$	-3	500	V
High side floating supply voltage ( $V_B$ vs. $V_S$ )	$V_{BS}$	12.5	17.5	
Low side power supply	$V_{DD}$	12.5	17.5	
Logic input voltages LIN, HIN, ITRIP	$V_{IN}$	0	5	

<sup>1</sup> Monitored by pin 24

## Static Parameters

( $T_c = 25^\circ\text{C}$ ,  $V_{DD} = 15\text{V}$ , if not stated otherwise)

Description	Condition	Symbol	Value			Unit
			min	typ	max	
Collector-Emitter breakdown voltage	$V_{IN} = 5\text{V}$ , $I_C = 0.25\text{mA}$	$V_{(BR)CES}$	600			V
Collector-Emitter saturation voltage	$I_{out} = \pm 15\text{A}$ $T_{vj} = 25^\circ\text{C}$ $T_{vj} = 150^\circ\text{C}$	$V_{CE(sat)}$	- -	1.65 1.9	2.1	V
Diode forward voltage	$V_{IN} = 5\text{V}$ , $I_{out} = \pm 15\text{A}$ $T_{vj} = 25^\circ\text{C}$ $T_{vj} = 150^\circ\text{C}$	$V_F$	- -	1.7 1.6	2.05	V
Zero gate voltage collector current of IGBT	$V_{CE} = 600\text{V}$ , $V_{IN} = 5\text{V}$ $T_{vj} = 25^\circ\text{C}$ $T_{vj} = 150^\circ\text{C}$	$I_{CES}$	- -	- -	40 1000	$\mu\text{A}$
Short circuit collector current <sup>1</sup>	$t_{SC} \leq 5\mu\text{s}$ $V_{CC} = 400\text{V}$ , $T_{vj} = 150^\circ\text{C}$	$I_{C(SC)}^2$	-	95	-	A
Logic "0" input voltage (LIN,HIN)		$V_{IH}$	1.7	2.1	2.4	V
Logic "1" input voltage (LIN,HIN)		$V_{IL}$	0.7	0.9	1.1	V
ITRIP positive going threshold		$V_{IT,TH+}$	360	460	540	mV
ITRIP input hysteresis		$V_{IT,HYS}$	45	75	-	mV
$V_{DD}$ and $V_{BS}$ supply undervoltage positive going threshold		$V_{DDUV+}$ $V_{BSUV+}$ <sup>2</sup>	11.0	12.1	12.8	V
$V_{DD}$ and $V_{BS}$ supply undervoltage negative going threshold		$V_{DDUV-}$ $V_{BSUV-}$ <sup>2</sup>	9.5	10.4	11.0	V
$V_{CC}$ and $V_{BS}$ supply undervoltage lockout hysteresis		$V_{DDUVH}$ $V_{BSUVH}$ <sup>2</sup>	1.2	1.7	-	V
Input clamp voltage (/HIN, /LIN)	$I_{IN} = 4\text{mA}$	$V_{INCLAMP}$	9.0	10.4	13.0	V
Input clamp voltage (ITRIP)	$I_{IN} = 4\text{mA}$	$V_{INCLAMP2}$	9.0	10.6	13.0	V
Quiescent $V_{Bx}$ supply current ( $V_{Bx}$ only)	$V_{HIN} = \text{low}$	$I_{QB}$	-	300	550	$\mu\text{A}$
Quiescent VDD supply current (VDD only)	$V_{IN} = \text{float}$	$I_{QDD}$	-	2.4	3.4	mA
Input bias current	$V_{IN} = 5\text{V}$	$I_{IN+}$	-	55	100	$\mu\text{A}$
Input bias current	$V_{IN} = 0\text{V}$	$I_{IN-}$	-	220	400	$\mu\text{A}$
ITRIP Input bias current	$V_{ITRIP} = 5\text{V}$	$I_{ITRIP+}$	-	75	120	$\mu\text{A}$
Leakage current of high side	$T_{j,IC} = 125^\circ\text{C}$	$I_{LVS}^2$	-	30	-	$\mu\text{A}$
FAULT low on resistance of the pull down transistors	$V_{FLT} = 0.5\text{V}$ , $V_{ITRIP} = 1\text{V}$	$R_{on,FLT}$	-	56	-	$\Omega$

<sup>1</sup> Allowed number of short circuits: <1000; time between short circuits: >1s.

<sup>2</sup> Test is not subject of product test, verified by characterisation

## Dynamic Parameters

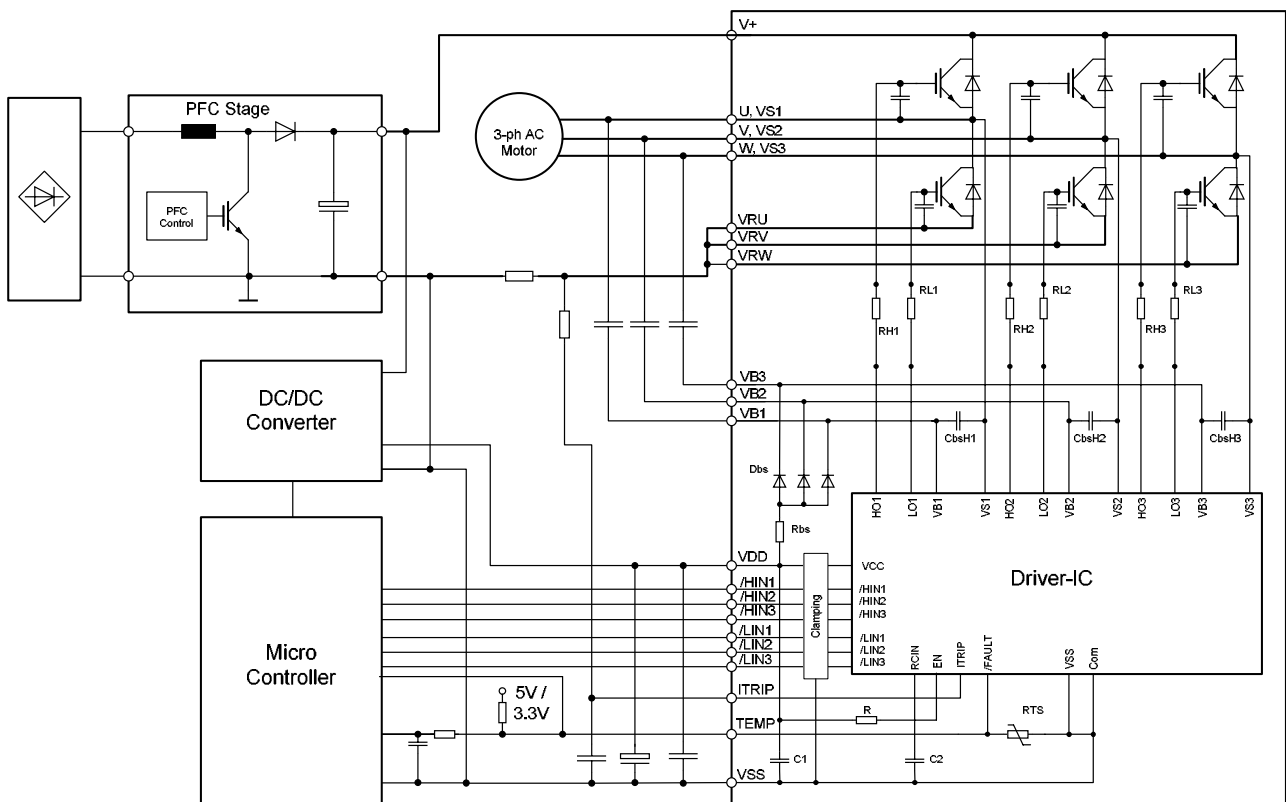
( $T_c = 25^\circ\text{C}$ ,  $V_{DD} = 15\text{V}$ , if not stated otherwise)

Description	Condition	Symbol	Value			Unit
			min	typ	max	
Turn-on propagation delay High side or low side	$V_{LIN,HIN} = 0\text{V}$ ; $I_{out} = 15\text{A}$ , $V_{DC} = 300\text{V}$	$t_{d(on)}$	-	718	-	ns
Turn-on rise time High side or low side	$V_{LIN,HIN} = 5\text{V}$ ; $I_{out} = 15\text{A}$ , $V_{DC} = 300\text{V}$	$t_r$	-	61	-	
Turn-off propagation delay High side or low side	$V_{LIN,HIN} = 5\text{V}$ ; $I_{out} = 15\text{A}$ , $V_{DC} = 300\text{V}$	$t_{d(off)}$	-	937	-	
Turn-off fall time High side or low side	$V_{LIN,HIN} = 0\text{V}$ ; $I_{out} = 15\text{A}$ , $V_{DC} = 300\text{V}$	$t_f$	-	74	-	
Shutdown propagation delay ITRIP	$V_{ITRIP} = 1\text{V}$ , $I_u, I_v, I_w = 15\text{A}$	$t_{ITRIP}$	-	1100	-	
Input filter time ITRIP	$V_{ITRIP} = 1\text{V}$	$t_{ITRIPmin}$	155	210	380	
Propagation delay ITRIP to FAULT	$V_{ITRIP} = 1\text{V}$	$t_{FLT}$		370		
Input filter time at LIN for turn on and off and input filter time at HIN for turn on only	$V_{LIN,HIN} = 0\text{V} \& 5\text{V}$	$t_{FILIN}$	120	270	-	
Input filter time at HIN for turn off	$V_{HIN} = 5\text{V}$	$t_{FILIN1}$	-	220	-	
Input filter time at HIN for turn off	$V_{HIN} = 5\text{V}$	$t_{FILIN2}$	-	400	-	
Fault clear time after ITRIP-fault	$V_{LIN,HIN} = 0\text{V} \& 5\text{V}$ $V_{ITRIP} = 0\text{V}$	$t_{FLTCLR}$	-	4.7	-	ms
Min. deadtime between low side and high side		$DT_{PWM}$	-	1.5	-	$\mu\text{s}$
Deadtime of gate drive circuit		$DT_{IC}$	-	380	-	ns
IGBT Turn-on Energy (includes reverse recovery of diode)	$I_{out} = 15\text{A}$ , $V_{DC} = 300\text{V}$ $T_{vj} = 25^\circ\text{C}$ $T_{vj} = 150^\circ\text{C}$	$E_{on}$	-	0.69	-	mJ
			-	0.93	-	
IGBT Turn-off Energy	$I_{out} = 15\text{A}$ , $V_{DC} = 300\text{V}$ $T_{vj} = 25^\circ\text{C}$ $T_{vj} = 150^\circ\text{C}$	$E_{off}$	-	0.27	-	
			-	0.37	-	
Diode recovery Energy	$I_{out} = 15\text{A}$ , $V_{DC} = 300\text{V}$ $T_{vj} = 25^\circ\text{C}$ $T_{vj} = 150^\circ\text{C}$	$E_{rec}$	-	0.07	-	
			-	0.17	-	

### Integrated Components

Description	Condition	Symbol <sup>1</sup>	Value			Unit
			min	typ	max	
Resistor		Rbs	-	10	-	Ω
Resistor	$T_{NTC} = 25^{\circ}\text{C}$	RTS	-	100	-	kΩ
B-Constant of NTC (Negative Temperature Coefficient)	$T_{NTC} = 25^{\circ}\text{C}$	B25	-	4250	-	K
Bootstrap diode forward voltage	$I_{FDbs} = 100\text{mA}$	$V_{FDbs}$	-	1.9	2.05	V
Capacitor		C1	-	100	-	nF
Capacitor		Cgex		0.39		
Bootstrap Capacitor		CbsH <sub>x</sub>	-	100	-	

### Typical Application



<sup>1</sup> Symbols according to Figure 1

### Characteristics

( $T_C = 25^\circ\text{C}$ ,  $V_{DD} = 15\text{V}$ , if not stated otherwise)

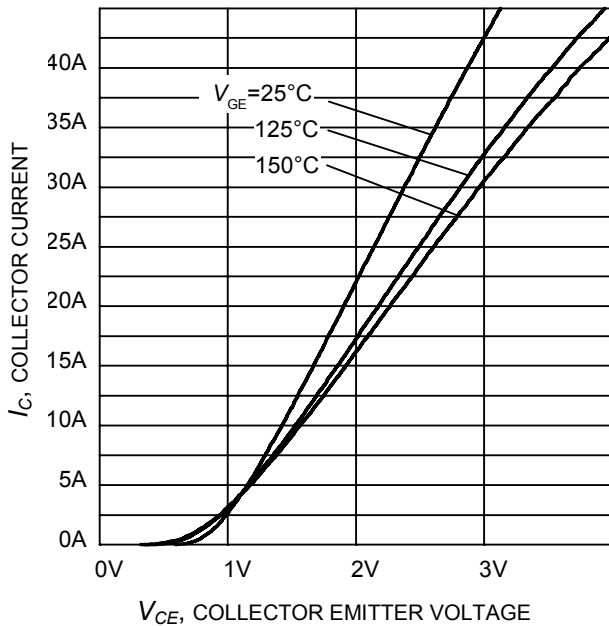


Figure 5. Typical IGBT output characteristic

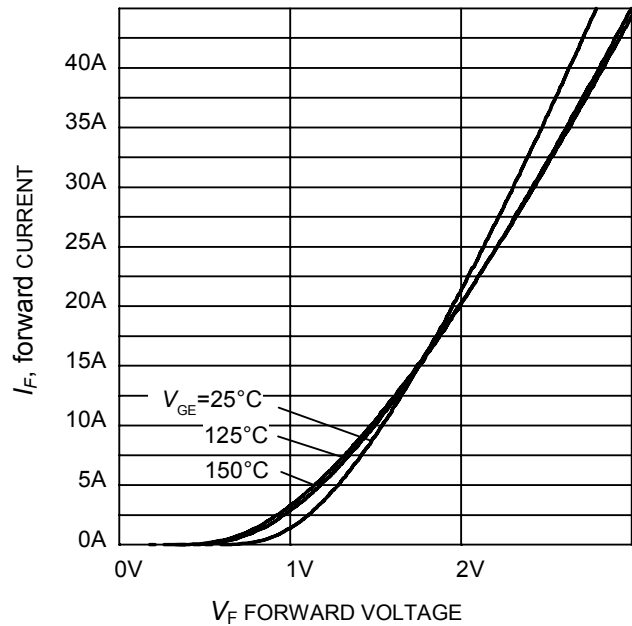


Figure 6. Typical diode forward current as a function of forward voltage

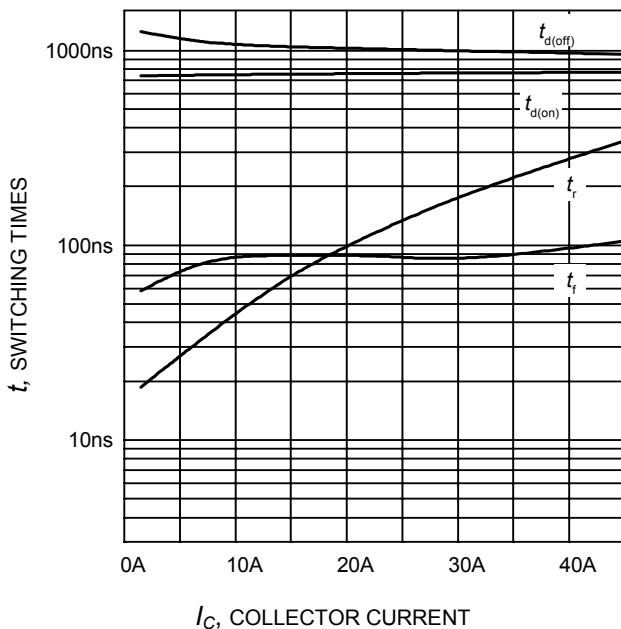


Figure 7. Typical switching times as a function of collector current (inductive load,  $T_J = 150^\circ\text{C}$ ,  $V_{CE} = 300\text{V}$  Dynamic test circuit in Figure A)

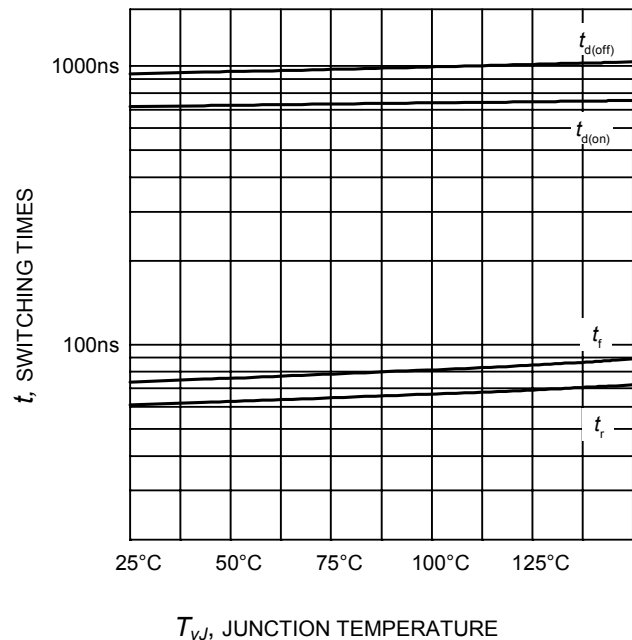
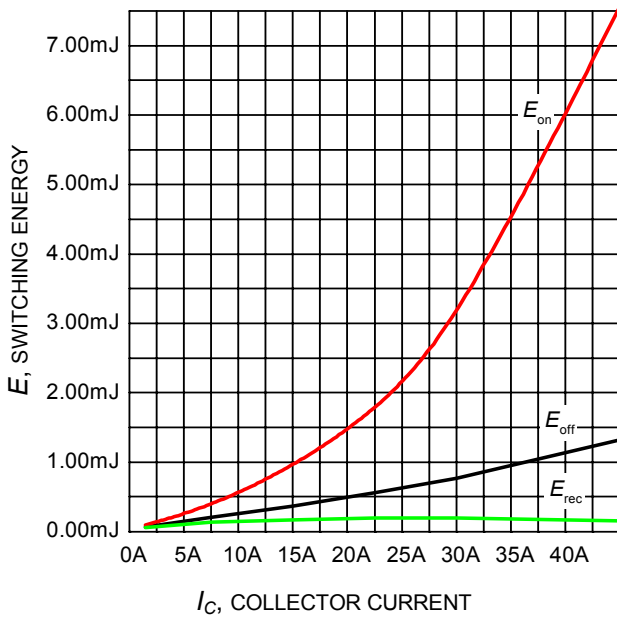
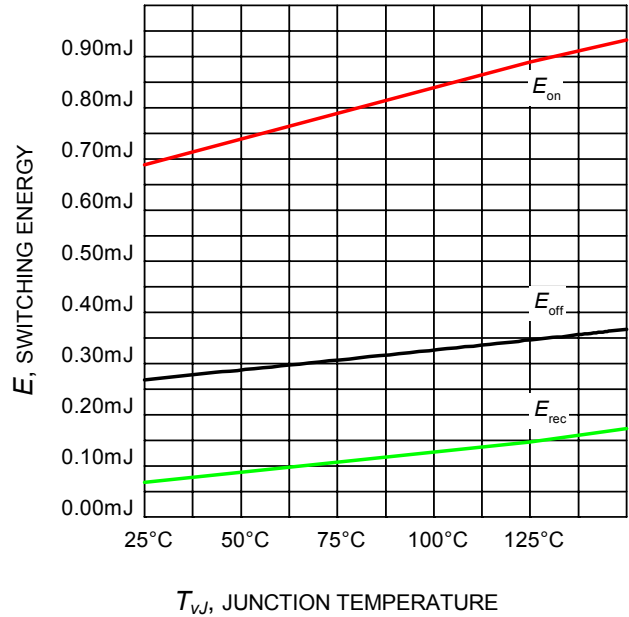


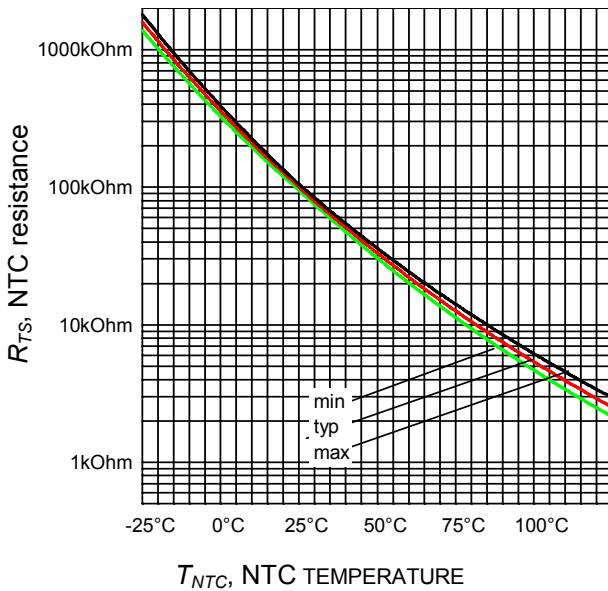
Figure 8. Typical switching times as a function of junction temperature (inductive load,  $V_{CE} = 300\text{V}$ ,  $I_C = 15\text{A}$  Dynamic test circuit in Figure A)



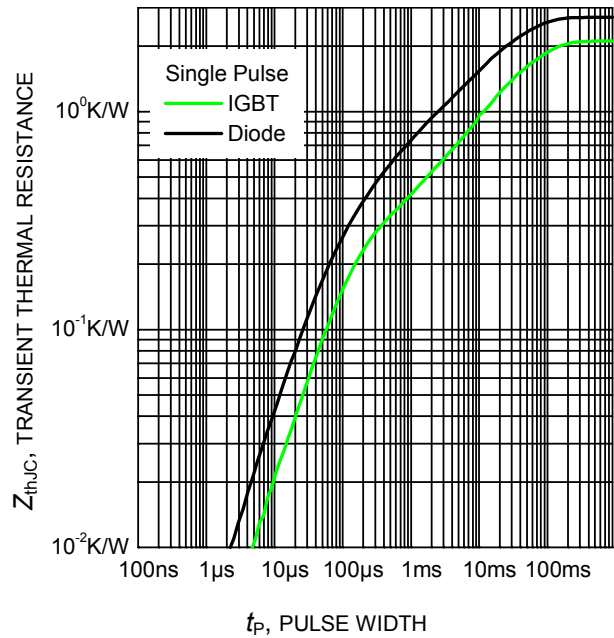
**Figure 9. Typical switching energy losses as a function of collector current** (inductive load,  $T_J = 150^\circ\text{C}$ ,  $V_{CE} = 300\text{V}$  Dynamic test circuit in Figure A)



**Figure 10. Typical switching energy losses as a function of junction temperature** (inductive load,  $V_{CE} = 300\text{V}$ ,  $I_C = 15\text{A}$  Dynamic test circuit in Figure A)

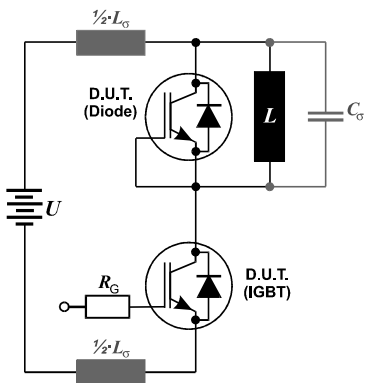


**Figure 11. Characteristic of NTC as a function of NTC temperature**

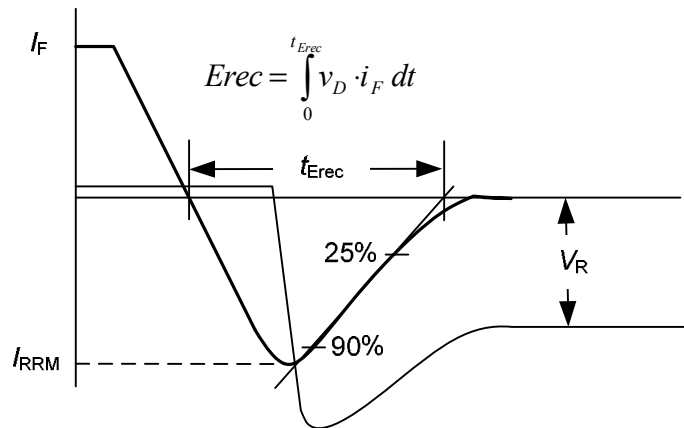


**Figure 12. Transient thermal impedance as a function of pulse width** ( $D = t_p/T$ )

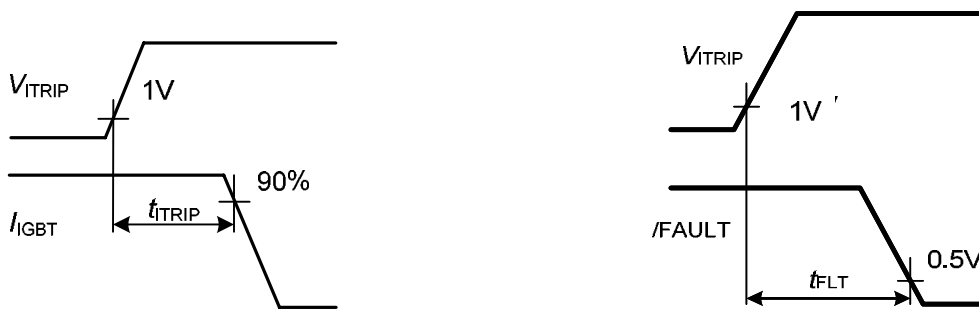
### Test Circuits and Parameter Definition



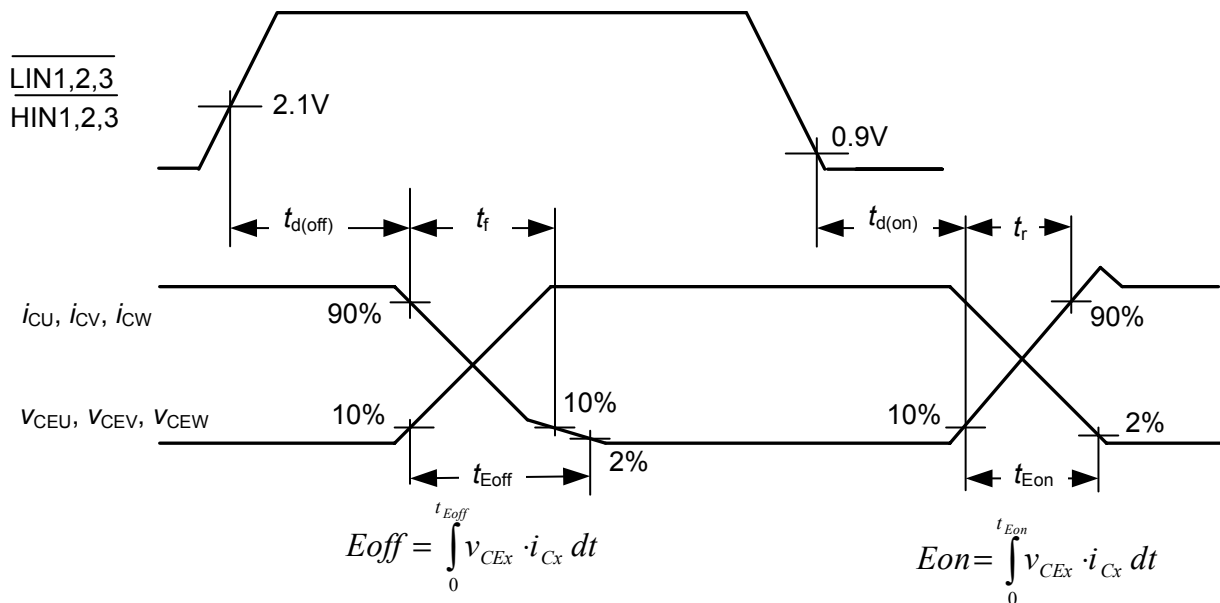
**Figure A: Dynamic test circuit**  
Leakage inductance  $L_\sigma = 180\text{nH}$   
Stray capacitance  $C_\sigma = 39\text{pF}$



**Figure B: Definition of diodes switching characteristics**



**Figure C: Definition of ITIRP propagation delay**



**Figure D: Switching times definition and switching energy definition**

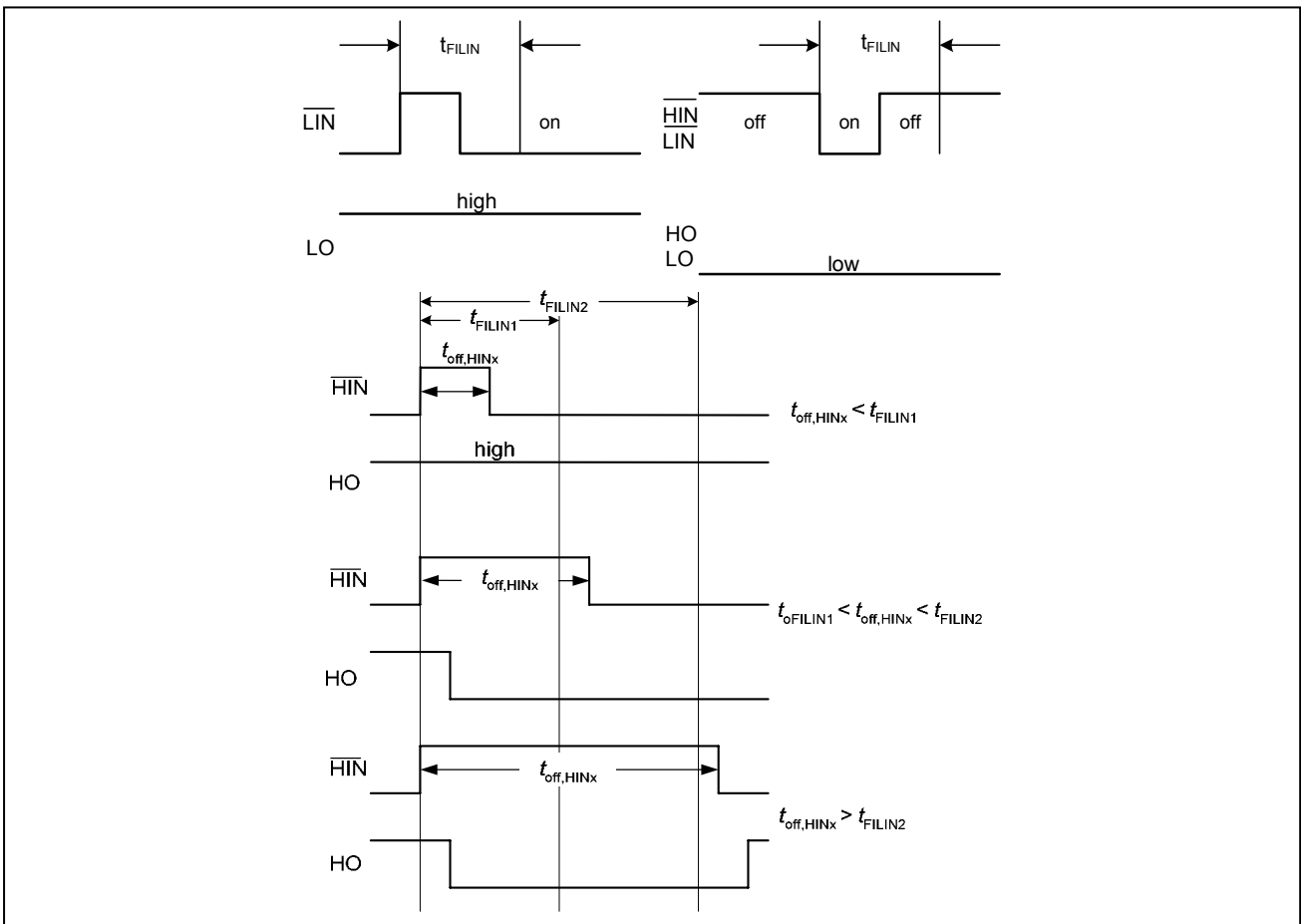
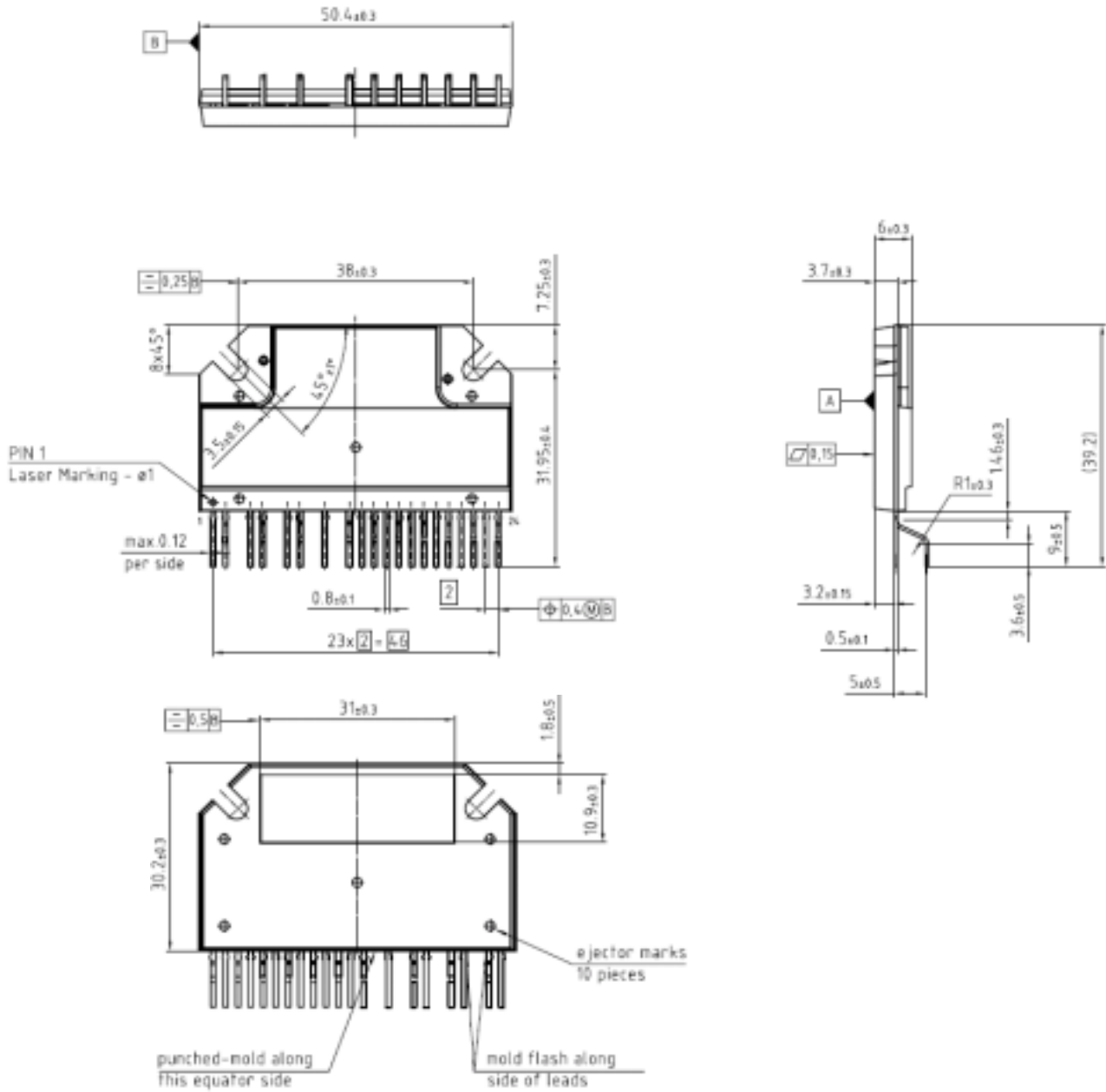


Figure E: Short Pulse suppression



Package Outline IKCS22F60F2A



Proprietary data Company confidential All rights reserved	Drawing according to ISO 8015 General tolerances MBS / 2T		Ver. 1.1		
DL 2004/2008	RARCZEWT		PACKAGE OUTLINE		Format
DL 2007/2007	RARCZEWT		PG-MSIP-20-1		A3
DL 2008/2007	RARCZEWT				Page
DL 2009/2005	RARCZEWT				00
DL 2009/2005	RARCZEWT	TW	PDL 200805002766 000 04		

Note: There may occur discolourations on the copper surface without any effect of the thermal properties.

