

## GaAs pHEMT SPDT NON-REFLECTIVE SWITCH, DC - 20 GHz

### Typical Applications

This switch is suitable DC - 20 GHz applications:

- Fiber Optics
- Microwave Radio
- Military
- Space
- VSAT

### Features

- High Isolation: >40 dB @ 20 GHz
- Low Insertion Loss: 2.4 dB @ 20 GHz
- Non-Reflective Design
- Small Size: 1.22 x 0.85 x 0.1 mm

### Functional Diagram

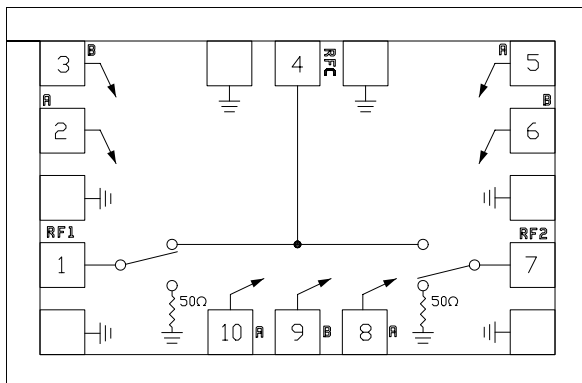

### General Description

The HMC347A is a broadband non-reflective GaAs pHEMT SPDT MMIC chip. Covering DC to 20 GHz, the switch offers high isolation and low insertion loss. The switch features over 52 dB isolation at lower frequencies and over 40 dB at higher frequencies due to the implementation of on-chip via hole structures. The switch operates using two negative control voltage logic lines of -5/0V, requires no Vee and has no current consumption. The switch operates down to DC. The chip features coplanar I/Os that allow 100% RF testing prior to delivery to the customer.

### Electrical Specifications, $T_A = +25^\circ\text{C}$ , With 0/-5V Control, 50 Ohm System

Parameter	Frequency	Min.	Typ.	Max.	Units
Insertion Loss	DC - 10.0 GHz		1.7	2.2	dB
	DC - 20.0 GHz		2.4	3.0	dB
Isolation	DC - 10.0 GHz	47	52		dB
	DC - 20.0 GHz	35	40		dB
Return Loss	DC - 20.0 GHz	9	12		dB
Return Loss RF1, RF2	DC - 20.0 GHz	8	11		dB
Input Power for 1 dB Compression	0.5 - 20.0 GHz	22	29		dBm
Input Third Order Intercept Two-tone Input Power = +10dBm/tone	0.5 - 20.0 GHz	40	45		dBm
Switching Characteristics					
tRISE, tFALL (10/90% RF)	DC - 20.0 GHz		3		ns
tON, tOFF (50% CTL to 10/90% RF)			10		ns

**GaAs pHEMT SPDT NON-REFLECTIVE SWITCH, DC - 20 GHz**

**Insertion Loss**

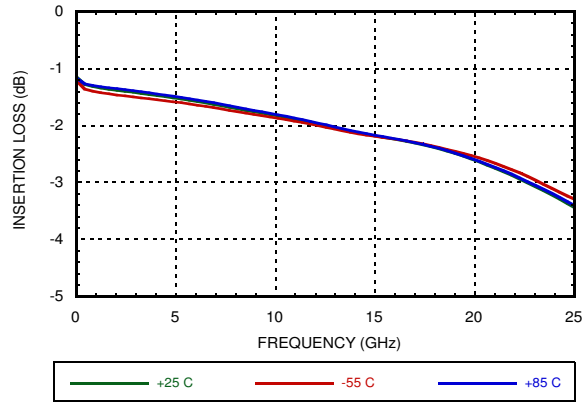

**Isolation**

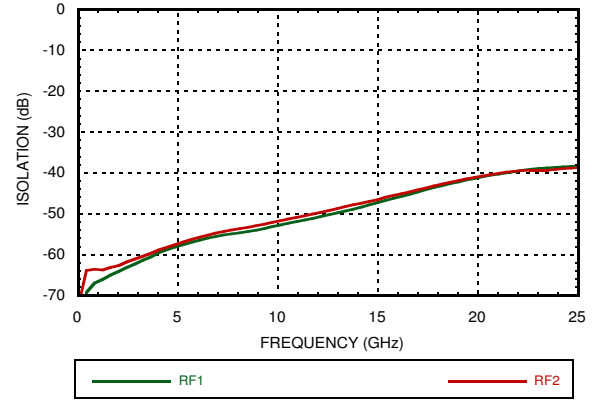

**Return Loss**

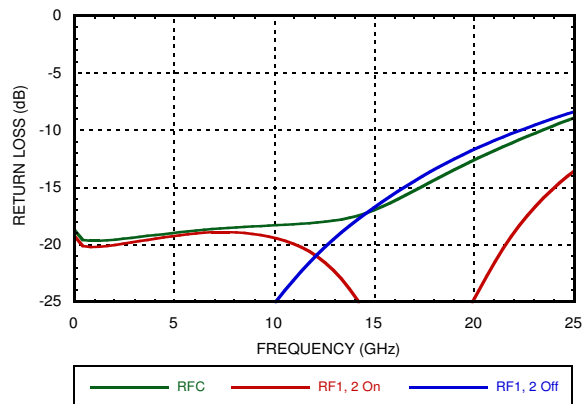

**0.1 and 1 dB Input Compression Point**

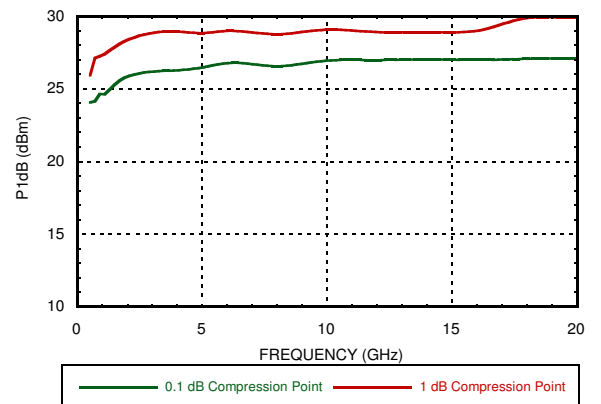

**Input Third Order Intercept Point**

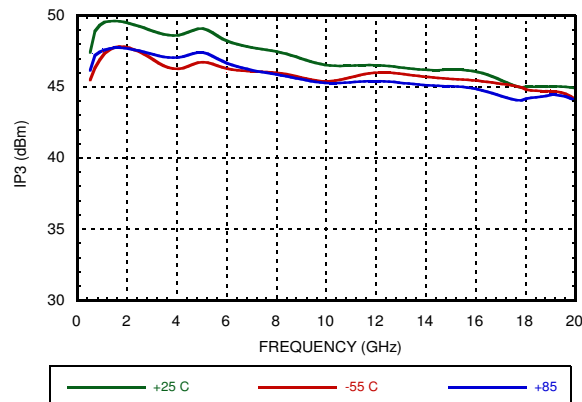

**GaAs pHEMT SPDT NON-REFLECTIVE SWITCH, DC - 20 GHz**

**Absolute Maximum Ratings**

RF Input Power (Vctl = -5V)	+27 dBm
Control Voltage Range (A & B)	+0.5V to -7.5 Vdc
Channel Temperature	150 °C
Thermal Resistance (Insertion Loss Path)	118 °C/W
Thermal Resistance (Terminated Path)	200 °C/W
Storage Temperature	-65 to +150 °C
Operating Temperature	-55 to +85 °C

**Control Voltages**

State	Bias Condition
Low	0 to -0.2V @ 10 uA Max.
High	-5V@3uA Typ.to -7V@40uA Max.(+/-0.5Vdc)

**Truth Table**

Control Input		Signal Path State	
A	B	RFC to RF1	RFC to RF2
High	Low	ON	OFF
Low	High	OFF	ON



ELECTROSTATIC SENSITIVE DEVICE  
OBSERVE HANDLING PRECAUTIONS

2

SWITCHES - CHIP

**Outline Drawing**

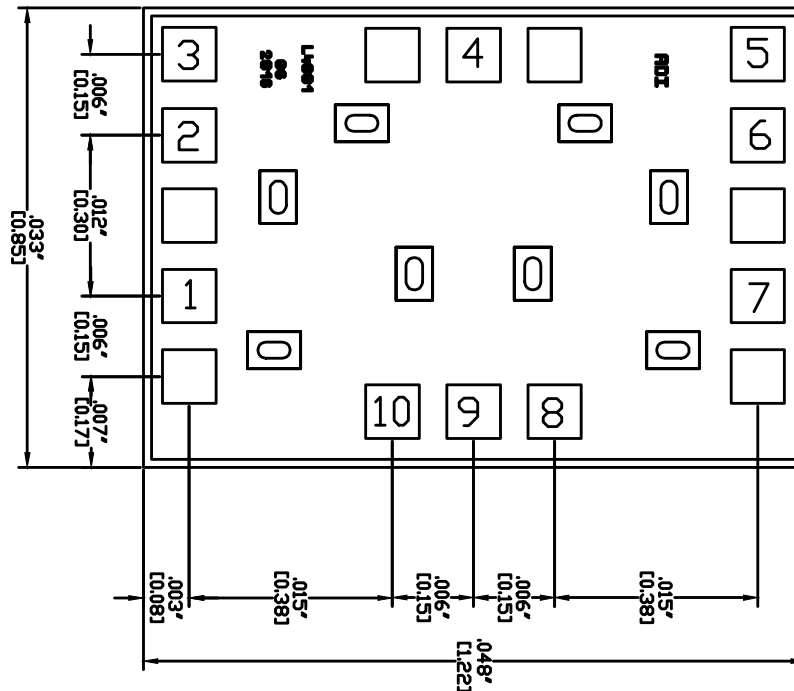

**Die Packaging Information [1]**

Standard	Alternate
WP-8 (Waffle Pack)	[2]

[1] Refer to the "Packaging Information" section for die packaging dimensions.

[2] For alternate packaging information contact Analog Devices Inc.

**GaAs pHEMT SPDT NON-REFLECTIVE SWITCH, DC - 20 GHz**

**Suggested Driver Circuit**

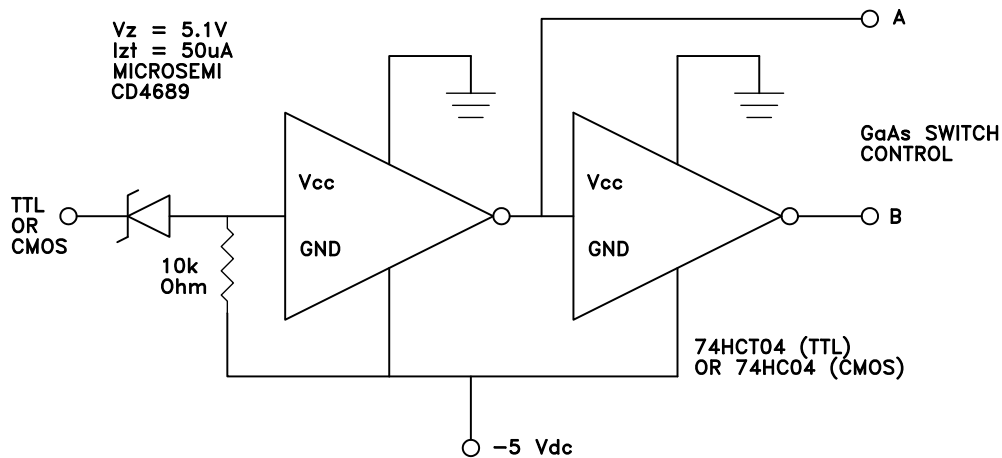

**Pad Descriptions**

Pad Number	Function	Description	Interface Schematic
1, 4, 7	RFC, RF1, RF2	This pad is DC coupled and matched to 50 Ohm. Blocking capacitors are required if the RF line potential is not equal to 0V.	
2, 5, 8, 10	CTRLA	See truth table and control voltage table.	
3, 6, 9	CTRLB	See truth table and control voltage table.	
	GND	Die bottom must be connected to RF ground.	

**GaAs pHEMT SPDT NON-REFLECTIVE  
SWITCH, DC - 20 GHz**

**Assembly Diagram**

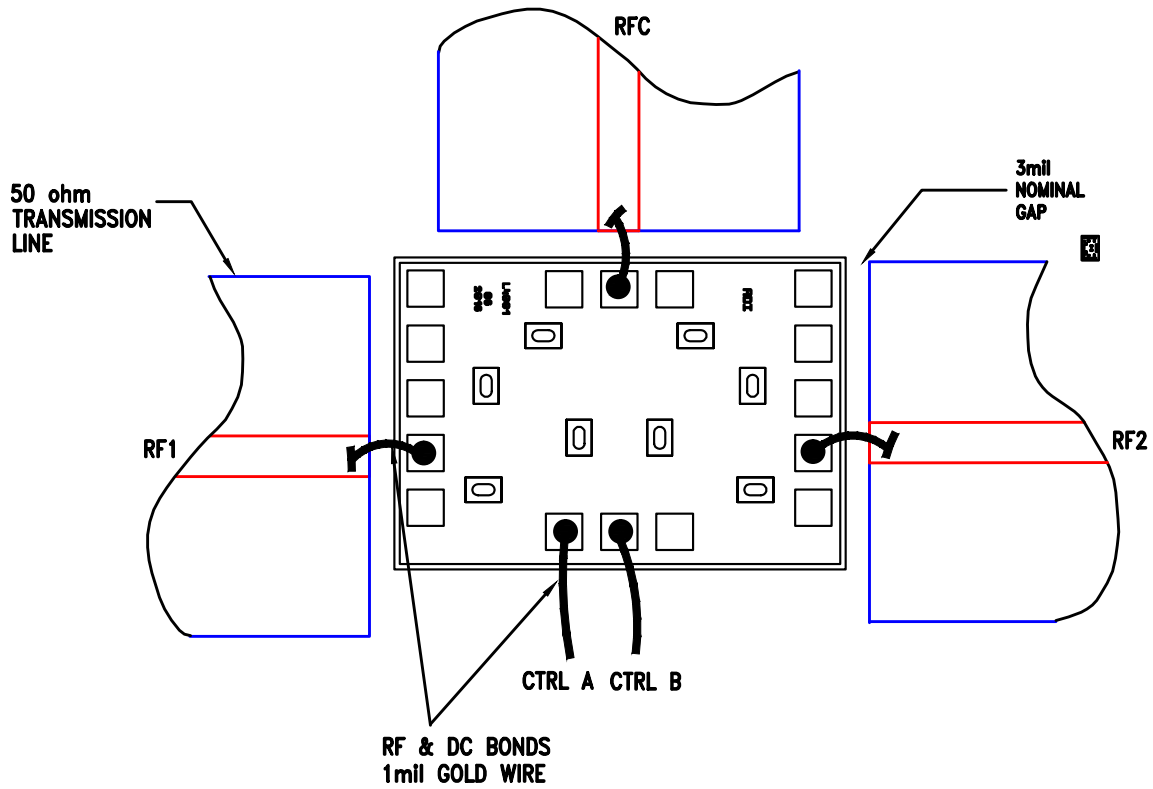

## GaAs pHEMT SPDT NON-REFLECTIVE SWITCH, DC - 20 GHz

### Mounting & Bonding Techniques for Millimeterwave GaAs MMICs

The die should be attached directly to the ground plane eutectically or with conductive epoxy (see HMC general Handling, Mounting, Bonding Note).

50 Ohm Microstrip transmission lines on 0.127mm (5 mil) thick alumina thin film substrates are recommended for bringing RF to and from the chip (Figure 1). If 0.254mm (10 mil) thick alumina thin film substrates must be used, the die should be raised 0.150mm (6 mils) so that the surface of the die is coplanar with the surface of the substrate. One way to accomplish this is to attach the 0.102mm (4 mil) thick die to a 0.150mm (6 mil) thick molybdenum heat spreader (moly-tab) which is then attached to the ground plane (Figure 2).

Microstrip substrates should be brought as close to the die as possible in order to minimize bond wire length. Typical die-to-substrate spacing is 0.076mm (3 mils).

#### Handling Precautions

*Follow these precautions to avoid permanent damage.*

**Storage:** All bare die are placed in either Waffle or Gel based ESD protective containers, and then sealed in an ESD protective bag for shipment. Once the sealed ESD protective bag has been opened, all die should be stored in a dry nitrogen environment.

**Cleanliness:** Handle the chips in a clean environment. DO NOT attempt to clean the chip using liquid cleaning systems.

**Static Sensitivity:** Follow ESD precautions to protect against ESD strikes.

**Transients:** Suppress instrument and bias supply transients while bias is applied. Use shielded signal and bias cables to minimize inductive pick-up.

**General Handling:** Handle the chip along the edges with a vacuum collet or with a sharp pair of bent tweezers. The surface of the chip has fragile air bridges and should not be touched with vacuum collet, tweezers, or fingers.

#### Mounting

The chip is back-metallized and can be die mounted with AuSn eutectic preforms or with electrically conductive epoxy. The mounting surface should be clean and flat.

**Eutectic Die Attach:** A 80/20 gold tin preform is recommended with a work surface temperature of 255 deg. C and a tool temperature of 265 deg. C. When hot 90/10 nitrogen/hydrogen gas is applied, tool tip temperature should be 290 deg. C. DO NOT expose the chip to a temperature greater than 320 deg. C for more than 20 seconds. No more than 3 seconds of scrubbing should be required for attachment.

**Epoxy Die Attach:** Apply a minimum amount of epoxy to the mounting surface so that a thin epoxy fillet is observed around the perimeter of the chip once it is placed into position. Cure epoxy per the manufacturer's schedule.

#### Wire Bonding

Ball or wedge bond with 0.025 mm (1 mil) diameter pure gold wire (DC bias, IF1 and IF2) or Ribbon Bond (RF and LO ports) 0.076 mm x 0.013 mm (3 mil x 0.5 mil) size is recommended. Thermosonic wirebonding with a nominal stage temperature of 150 °C and a ball bonding force of 40 to 50 grams or wedge bonding force of 18 to 22 grams is recommended. Use the minimum level of ultrasonic energy to achieve reliable wirebonds. Wirebonds should be started on the chip and terminated on the package or substrate. All bonds should be as short as possible <0.31 mm (12 mils).

