



## FXLS8471Q, 3-Axis, Linear Accelerometer

FXLS8471Q is a small, low-power, 3-axis, linear accelerometer in a 3 mm x 3 mm x 1 mm QFN package. FXLS8471Q has dynamically selectable acceleration full-scale ranges of  $\pm 2 g/\pm 4 g/\pm 8 g$  and 14 bits of resolution. Output data rates (ODR) are programmable from 1.563 Hz to 800 Hz. I<sup>2</sup>C and SPI serial digital interfaces are provided along with several user programmable event detection functions that can be used to reduce the overall system power consumption by off-loading the host processor. FXLS8471Q is guaranteed to operate over the extended temperature range of -40 °C to +85 °C.

### Features

- 1.95 V to 3.6 V VDD supply voltage, 1.62 V to 3.6 V VDDIO voltage
- $\pm 2 g/\pm 4 g/\pm 8 g$  dynamically selectable acceleration full-scale ranges
- Output Data Rates (ODR) from 1.563 Hz to 800 Hz
- Low noise: typically 99  $\mu\text{g}/\text{Hz}$  in low-noise mode @ 200-Hz bandwidth
- 14-bit ADC resolution: 0.244 mg/LSB in  $\pm 2 g$ , full-scale range
- Embedded programmable acceleration event functions:
  - Freelfall and Motion Detection
  - Transient Detection
  - Vector-Magnitude Change Detection
  - Pulse and Tap Detection (Single and Double)
  - Orientation Detection (Portrait/Landscape)
- Programmable automatic ODR change using Auto-Wake and return to Sleep functions to save power.
- 192-byte FIFO buffer, capable of storing up to 32 samples of X/Y/Z data
- Supports 4-wire SPI interface at up to 1 MHz; I<sup>2</sup>C Normal (100 kHz) and Fast Modes (400 kHz)
- Integrated accelerometer self-test function

### Target Markets

- Industrial applications: vibration analysis, machine health monitoring, and platform stabilization
- Smartphones, tablets, digital cameras, and personal navigation devices
- Medical applications: patient monitoring, fall detection, and rehabilitation

### Applications

- Shock and vibration monitoring (mechatronic compensation, shipping, and warranty usage logging)
- User interface (menu scrolling by orientation change, tap detection for button replacement)
- Orientation detection (portrait/landscape: up/down, left/right, back/front position identification)
- Gaming and real-time activity analysis (pedometry, freelfall and drop detection for hard disk drives and other devices)
- Power management for mobile devices using inertial event detection

## FXLS8471Q



**16 LEAD QFN**  
**3 mm x 3 mm x 1 mm**

### Top View

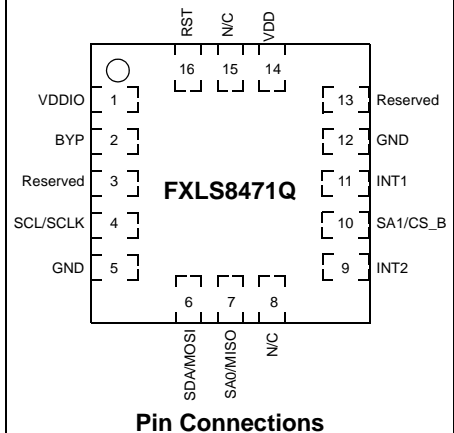

Freescale reserves the right to change the detail specifications as may be required to permit improvements in the design of its products.

© 2013-2015 Freescale Semiconductor, Inc. All rights reserved.



ORDERING INFORMATION			
Part Number	Temperature Range	Package Description	Shipping
FXLS8471QR1	-40°C to +85°C	QFN-16	Tape and Reel (1 k)

## Related Documentation

The FXLS8471Q device features and operations are described in a variety of reference manuals, user guides, and application notes. To find the most-current versions of these documents:

1. Go to the Freescale homepage at:

<http://www.freescale.com/>

2. In the Keyword search box at the top of the page, enter the device number FXLS8471Q.

In the Refine Your Result pane on the left, click on the Documentation link.

# Contents

<b>1</b>	<b>Block Diagram</b>	<b>5</b>
<b>2</b>	<b>Pin Description</b>	<b>6</b>
2.1	Soldering information	7
2.2	Orientation	8
<b>3</b>	<b>Example FXLS8471Q Driver Code</b>	<b>9</b>
3.1	Introduction	9
3.2	FXLS8471Q Addresses	9
3.3	Sensor data structure	9
3.4	FXLS8471Q Configuration function	10
3.5	FXLS8471Q Data Read function	11
<b>4</b>	<b>Terminology</b>	<b>12</b>
4.1	Sensitivity	12
4.2	Zero-g Offset	12
4.3	Self-Test	12
<b>5</b>	<b>Device Characteristics</b>	<b>13</b>
5.1	Mechanical characteristics	13
5.2	Electrical characteristics	14
5.3	Absolute maximum ratings	15
<b>6</b>	<b>Digital Interfaces</b>	<b>16</b>
6.1	I <sup>2</sup> C interface characteristics	16
6.1.1	General I <sup>2</sup> C operation	17
6.1.2	I <sup>2</sup> C Read/Write operations	17
6.2	SPI Interface characteristics	19
6.2.1	General SPI operation	19
6.2.2	SPI READ/WRITE operations	20
6.2.3	I <sup>2</sup> C/SPI auto detection	20
6.2.4	Power supply sequencing and I <sup>2</sup> C/SPI mode auto-detection	20
<b>7</b>	<b>Modes of Operation</b>	<b>21</b>
<b>8</b>	<b>Embedded Functionality</b>	<b>22</b>
8.1	Factory calibration	22
8.2	8-bit or 14-bit data	22
8.3	Low-power modes versus high-resolution modes	22
8.4	Auto-Wake/Sleep mode	23
8.5	Freefall and Motion event detection	23
8.5.1	Freefall detection	23
8.5.2	Motion detection	23
8.6	Transient detection	23
8.7	Pulse detection	23
8.8	Orientation detection	24
8.9	Acceleration Vector-Magnitude detection	24
<b>9</b>	<b>Register Map</b>	<b>25</b>
<b>10</b>	<b>Registers by Functional Blocks</b>	<b>28</b>
10.1	Device configuration	28
10.1.1	STATUS (0x00) register	28
10.1.2	DR_STATUS (0x00) register	28
10.1.3	F_STATUS (0x00) register	29
10.1.4	TRIG_CFG (0x0A) register	30
10.1.5	SYSMOD (0x0B) register	30
10.1.6	INT_SOURCE (0x0C) register	31
10.1.7	WHO_AM_I (0x0D) register	32
10.1.8	CTRL_REG1 (0x2A) register	32
10.1.9	CTRL_REG2 (0x2B) register	33
10.1.10	CTRL_REG3 [Interrupt Control Register] (0x2C) register	35
10.1.11	CTRL_REG4 [Interrupt Enable Register] (0x2D) register	36
10.1.12	CTRL_REG5 [Interrupt Routing Configuration Register] (0x2E) register	37
10.2	Auto-Sleep trigger	39
10.2.1	ASLP_COUNT (0x29) register	39
10.3	Output data registers	41
10.3.1	OUT_X_MSB (0x01), OUT_X_LSB (0x02), OUT_Y_MSB (0x03), OUT_Y_LSB (0x04), OUT_Z_MSB (0x05), OUT_Z_LSB (0x06) registers	41
10.4	FIFO	42
10.4.1	F_SETUP (0x09) register	42
10.5	Sensor data configuration	43

10.5.1	XYZ_DATA_CFG (0x0E) register	43
10.6	High-Pass filter	43
10.6.1	HP_FILTER_CUTOFF (0x0F) register	43
10.7	Portrait/Landscape Detection	45
10.7.1	PL_STATUS (0x10) register	46
10.7.2	PL_CFG (0x11) register	47
10.7.3	PL_COUNT (0x12) register	47
10.7.4	PL_BF_ZCOMP (0x13) register	48
10.7.5	PL_THS_REG (0x14) register	49
10.8	Freefall and Motion detection	49
10.8.1	A_FFMT_CFG (0x15) register	50
10.8.2	A_FFMT_SRC (0x16) register	51
10.8.3	A_FFMT_THS (0x17), A_FFMT_THS_X_MSB (0x73), A_FFMT_THS_X_LSB (0x74), A_FFMT_THS_Y_MSB (0x75), A_FFMT_THS_Y_LSB (0x76), A_FFMT_THS_Z_MSB (0x77), A_FFMT_THS_Z_LSB (0x78) registers	52
10.8.4	A_FFMT_COUNT (0x18) register	53
10.9	Accelerometer vector-magnitude function	55
10.9.1	A_VECM_CFG (0x5F) register	55
10.9.2	A_VECM_THS_MSB (0x60) register	56
10.9.3	A_VECM_THS_LSB (0x61) register	56
10.9.4	A_VECM_CNT (0x62) register	56
10.9.5	A_VECM_INITX_MSB (0x63) register	57
10.9.6	A_VECM_INITX_LSB (0x64) register	57
10.9.7	A_VECM_INITY_MSB (0x65) register	57
10.9.8	A_VECM_INITY_LSB (0x66) register	57
10.9.9	A_VECM_INITZ_MSB (0x67) register	57
10.9.10	A_VECM_INITZ_LSB (0x68) register	58
10.10	Transient (AC) acceleration detection	58
10.10.1	TRANSIENT_CFG (0x1D) register	58
10.10.2	TRANSIENT_SRC (0x1E) register	59
10.10.3	TRANSIENT_THS (0x1F) register	60
10.10.4	TRANSIENT_COUNT (0x20) register	60
10.11	Pulse detection	61
10.11.1	PULSE_CFG (0x21) register	61
10.11.2	PULSE_SRC (0x22) register	62
10.11.3	PULSE_THSX (0x23) register	62
10.11.4	PULSE_THSY (0x24) register	63
10.11.5	PULSE_THSZ (0x25) register	63
10.11.6	PULSE_TMLT (0x26) register	63
10.11.7	PULSE_LTCY (0x27) register	64
10.11.8	PULSE_WIND (0x28) register	65
10.12	Offset correction	66
10.12.1	OFF_X (0x2F) register	66
10.12.2	OFF_Y (0x30) register	66
10.12.3	OFF_Z (0x31) register	66
<b>11</b>	<b>Mounting Guidelines for the Quad Flat No-Lead (QFN) Package</b>	<b>67</b>
11.1	Overview of soldering considerations	67
11.2	Halogen content	67
11.3	PCB mounting recommendations	67
<b>12</b>	<b>Package Thermal Characteristics</b>	<b>69</b>
<b>13</b>	<b>Package</b>	<b>70</b>
<b>Appendix A</b>		<b>73</b>
A.1	Errata	73
A.1.1	SPI Mode Soft-reset using CTRL_REG2 (0x2B), bit 6	73
<b>14</b>	<b>Revision History</b>	<b>74</b>

# 1 Block Diagram

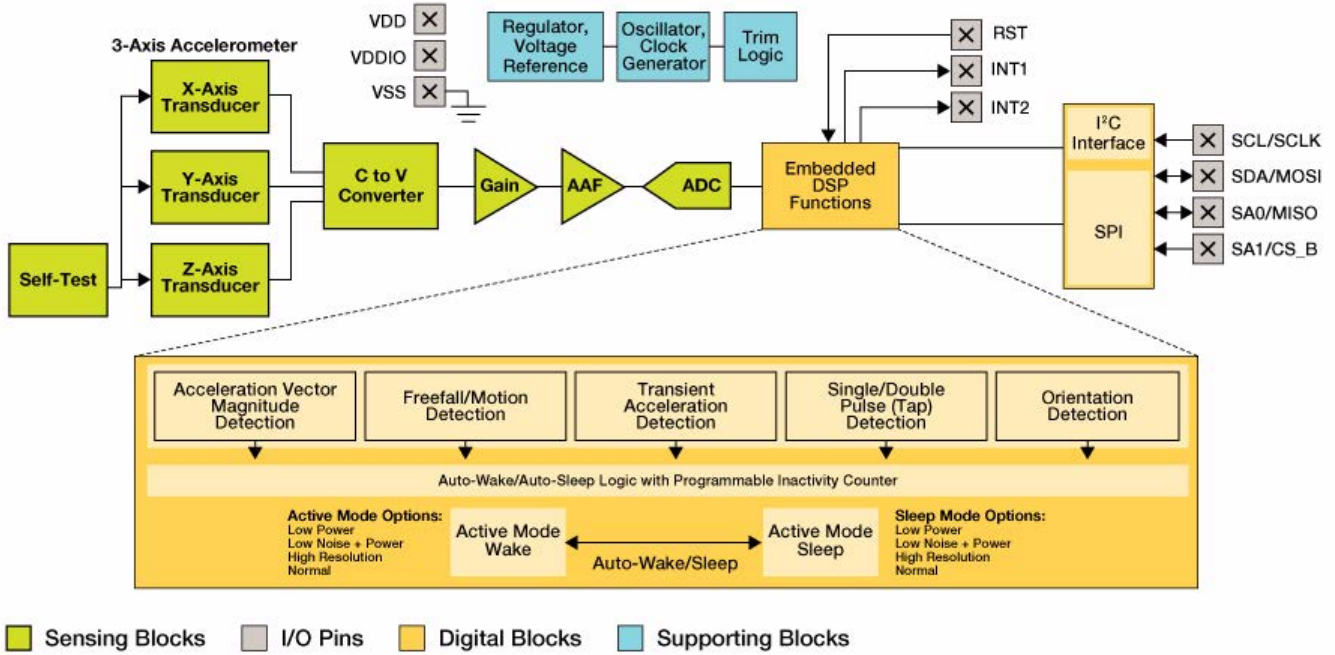
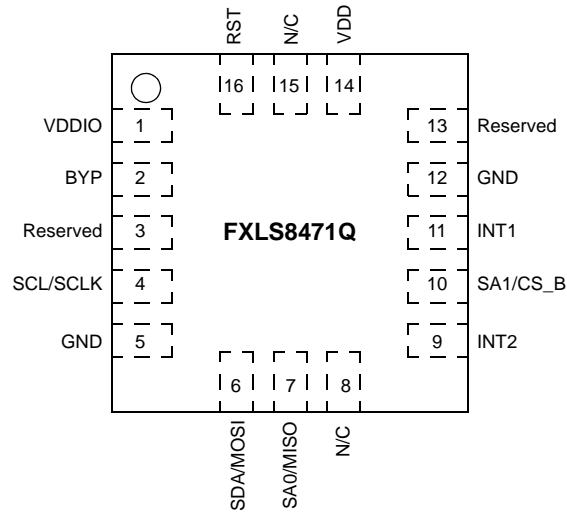

Figure 1. Block diagram

## 2 Pin Description



**Top View**  
**16 Lead QFN-COL**  
**3 mm x 3 mm x 1 mm**

**Figure 2. Pinout diagram**

**Table 1. Pin Description**

Pin	Name	Function
1	VDDIO	Interface power supply
2	BYP	Internal regulator output bypass capacitor connection
3	Reserved	Test reserved, connect to GND
4	SCL/SCLK	I <sup>2</sup> C Serial Clock/SPI Clock
5	GND	Ground
6	SDA/MOSI	I <sup>2</sup> C Serial Data/SPI Master Out, Slave In
7	SA0/MISO <sup>(1)</sup>	I <sup>2</sup> C address selection bit 0/SPI Master In, Slave Out
8	N/C	Internally not connected
9	INT2	Interrupt 2
10	SA1/CS_B	I <sup>2</sup> C address selection bit 1 <sup>(2)</sup> /SPI Chip Select (active low)
11	INT1	Interrupt 1
12	GND	Ground
13	Reserved	Test reserved, connect to GND
14	VDD	Power supply
15	N/C	Internally not connected
16	RST	Reset input, active high. Connect to GND if unused

1. The SA0 pin is also used to select the desired serial interface mode during POR and also after a hard/soft reset event. Please see [Section 6.2.3, "I<sup>2</sup>C/SPI auto detection"](#) for more information

2. See [Table 8](#) for I<sup>2</sup>C address options selectable using the SA0 and SA1 pins.

Device power is supplied through the VDD pin. Power-supply, decoupling capacitors (100 nF ceramic plus 4.7 μF or larger bulk) should be placed as close as possible to pin 14 of the device. The digital interface supply voltage (VDDIO) must also be decoupled with a 100 nF ceramic capacitor placed as close as possible to pin 1 of the device.

The digital control signals SCL, SDA, SA0, SA1, and RST are not tolerant of voltages more than VDDIO + 0.3 V. If VDDIO is removed, these pins will clamp any logic signals through their internal ESD protection diodes.

The function and timing of the two interrupt pins (INT1 and INT2) are user-programmable through the I<sup>2</sup>C/SPI interface. The SDA and SCL I<sup>2</sup>C connections are open drain and therefore require a pullup resistor as shown in the application diagram in Figure 3. The INT1 and INT2 pins may also be configured for open-drain operation. If they are configured for open drain, external pullup resistors are required.

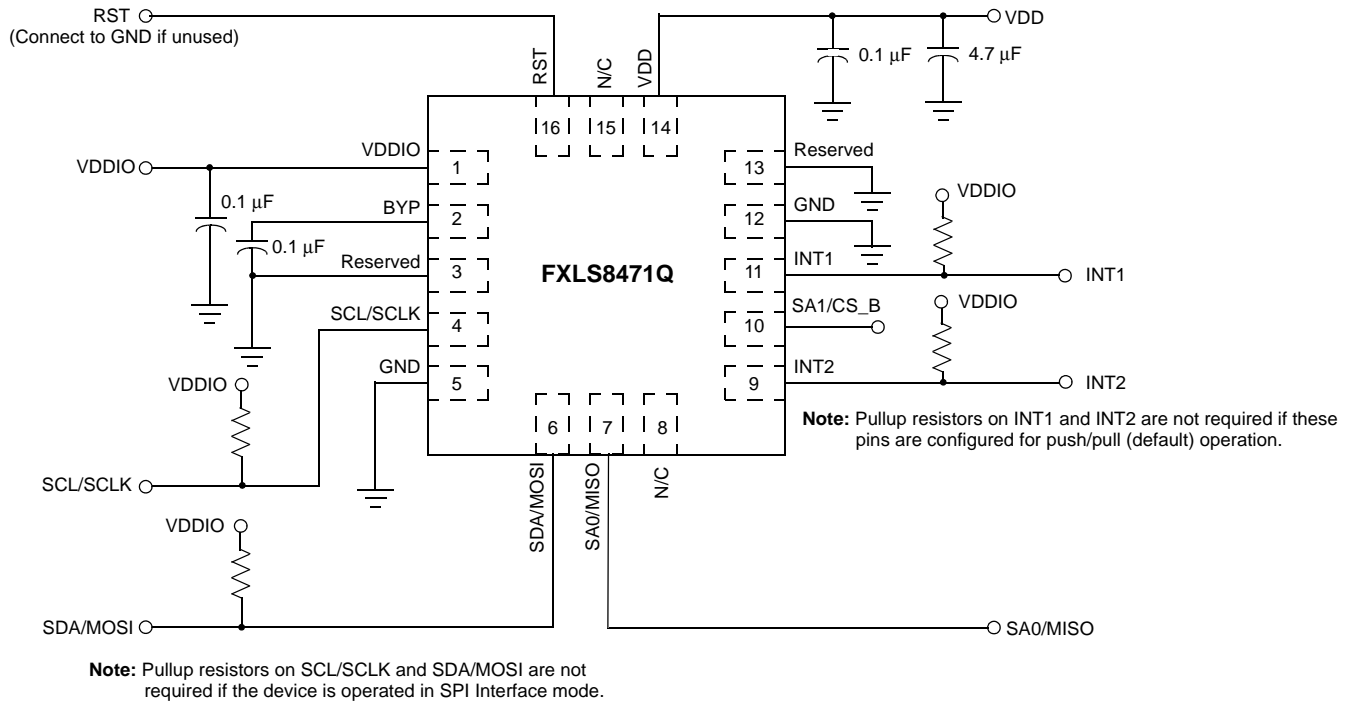

Figure 3. Electrical connection

## 2.1 Soldering information

The QFN package is compliant with the RoHS standards. Please refer to Freescale application note AN4077 for more information.

## 2.2 Orientation

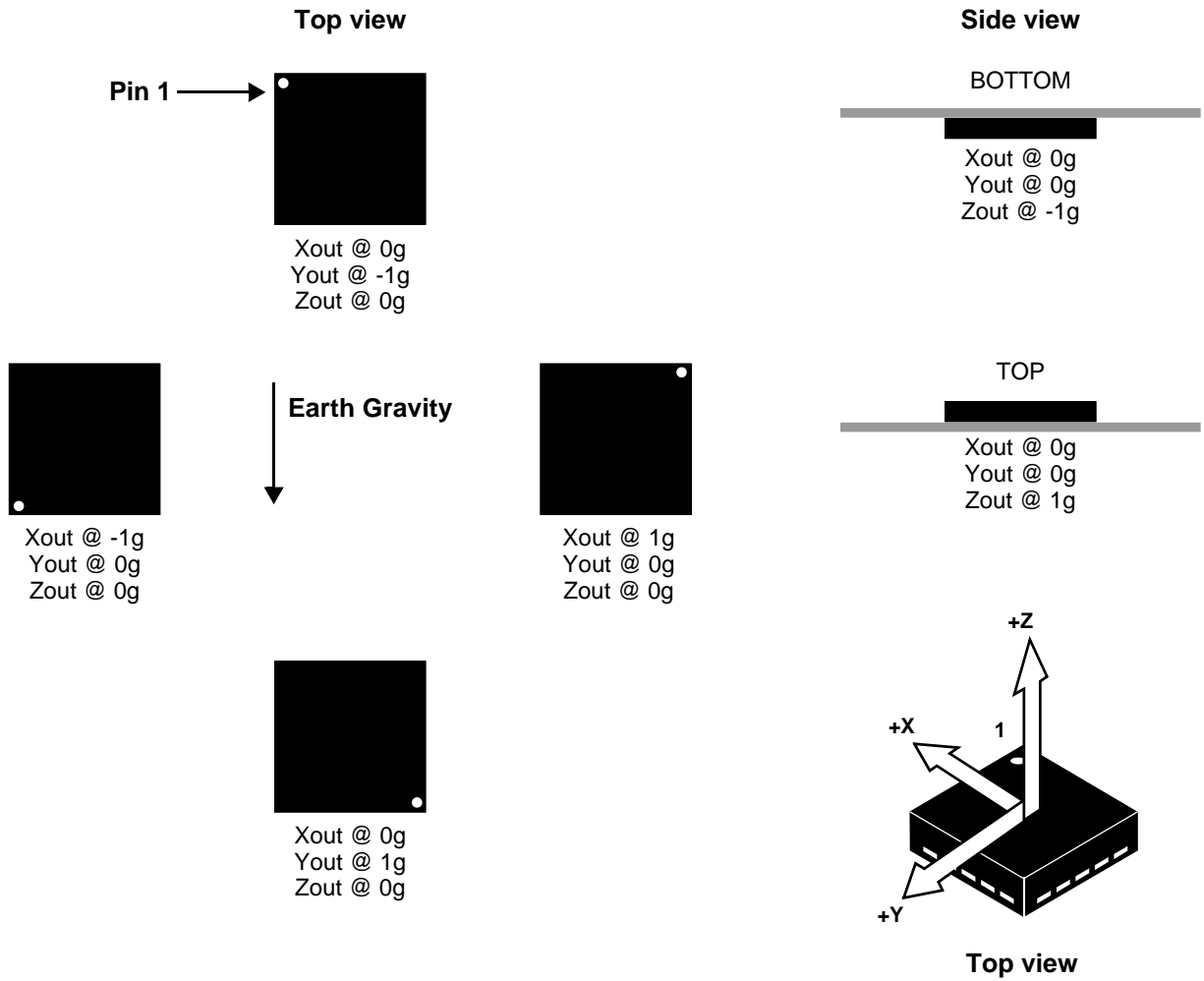

Figure 4. Component axes orientation and response to gravity stimulus



## 3 Example FXLS8471Q Driver Code

### 3.1 Introduction

It is very straightforward to configure the FXLS8471Q and start receiving data from the three accelerometer channels. Unfortunately, since every hardware platform will be different, it is not possible to provide completely portable software drivers. This section therefore provides real FXLS8471Q driver code for a Kinetis uC board running under the MQX operating system. The I<sup>2</sup>C functions `s_i2c_read_regs` and `s_i2c_write_regs` are not provided here and should be replaced with the corresponding low level I<sup>2</sup>C driver code on the development platform.

### 3.2 FXLS8471Q Addresses

This section lists the I<sup>2</sup>C address of the FXLS8471Q. The I<sup>2</sup>C address depends on the logic level of FXLS8471Q pins SA0 and SA1 so the I<sup>2</sup>C address may be 0x1C, 0x1D, 0x1E or 0x1F.

---

#### Example 1.

```
// FXLS8471Q I2C address
#define FXLS8471Q_SLAVE_ADDR    0x1E    // with pins SA0=0, SA1=0
```

---

Some of the key FXLS8471Q internal register addresses are listed below.

---

#### Example 2.

```
// FXLS8471Q internal register addresses
#define FXLS8471Q_STATUS        0x00
#define FXLS8471Q_WHOAMI       0x0D
#define FXLS8471Q_XYZ_DATA_CFG 0x0E
#define FXLS8471Q_CTRL_REG1    0x2A
#define FXLS8471Q_WHOAMI_VAL   0x6A
```

---

The reference driver here does a block read of the FXLS8471Q status byte plus three 16-bit accelerometer channels.

---

#### Example 3.

```
// number of bytes to be read from FXLS8471Q
#define FXLS8471Q_READ_LEN 7// status plus 3 accelerometer channels
```

---

### 3.3 Sensor data structure

The high and low bytes of the three accelerometer are placed into a structure of type `SRAWDATA` containing three signed short integers.

---

#### Example 4.

```
typedef struct
{
    int16_t  x;
    int16_t  y;
    int16_t  z;
} SRAWDATA;
```

---

### 3.4 FXLS8471Q Configuration function

This function configures the FXLS8471Q for a 200-Hz ODR. The code is self-explanatory and can be easily customized for different settings.

#### Example 5.

---

```
// function configures FXLS8471Q accelerometer sensor
static_mqx_int s_FXLS8471Q_start(MQX_FILE_PTR aFP)
{
    uint8_t databyte;

    // read and check the FXLS8471Q WHOAMI register
    if (s_i2c_read_regs(aFP, FXLS8471Q_SLAVE_ADDR, FXLS8471Q_WHOAMI, &databyte,
        (uint8_t) 1) != 1)
    {
        return (I2C_ERROR);
    }
    if (databyte != FXLS8471Q_WHOAMI_VAL)
    {
        return (I2C_ERROR);
    }

    // write 0000 0000 = 0x00 to accelerometer control register 1 to place FXLS8471Q into
    // standby
    // [7-1] = 0000 000
    // [0]: active=0
    databyte = 0x00;
    if (s_i2c_write_regs(aFP, FXLS8471Q_SLAVE_ADDR, FXLS8471Q_CTRL_REG1, &databyte,
        (uint8_t) 1) != 1)
    {
        return (I2C_ERROR);
    }

    // write 0000 0001= 0x01 to XYZ_DATA_CFG register
    // [7]: reserved
    // [6]: reserved
    // [5]: reserved
    // [4]: hpf_out=0
    // [3]: reserved
    // [2]: reserved
    // [1-0]: fs=01 for accelerometer range of +/-4g with 0.488mg/LSB
    databyte = 0x01;
    if (s_i2c_write_regs(aFP, FXLS8471Q_SLAVE_ADDR, FXLS8471Q_XYZ_DATA_CFG,
        &databyte, (uint8_t) 1) != 1)
    {
        return (I2C_ERROR);
    }

    // write 0001 0101b = 0x15 to accelerometer control register 1
    // [7-6]: aslp_rate=00
    // [5-3]: dr=010 for 200Hz data rate
    // [2]: lnoise=1 for low noise mode
    // [1]: f_read=0 for normal 16 bit reads
    // [0]: active=1 to take the part out of standby and enable sampling
    databyte = 0x15;
    if (s_i2c_write_regs(aFP, FXLS8471Q_SLAVE_ADDR, FXLS8471Q_CTRL_REG1, &databyte,
        (uint8_t) 1) != 1)
```

```

{
    return (I2C_ERROR);
}

// normal return
return (I2C_OK);
}

```

---

### 3.5 FXLS8471Q Data Read function

This function performs a block read of the status and acceleration data and places the bytes read into the structures of type SRAWDATA as signed short integers.

#### Example 6.

```

// read status and the three channels of accelerometer data from
// FXLS8471Q (7 bytes)
int16_t ReadAccel(SRAWDATA *pAccelData)
{
    MQX_FILE_PTR fp;                // I2C file pointer
    uint8_t Buffer[FXLS8471Q_READ_LEN]; // read buffer

    // read FXLS8471Q_READ_LEN=7 bytes (status byte and the three channels of data)
    if (s_i2c_read_regs(fp, FXLS8471Q_SLAVE_ADDR, FXLS8471Q_STATUS, Buffer,
        FXLS8471Q_READ_LEN) == FXLS8471Q_READ_LEN)
    {
        // copy the 14 bit accelerometer byte data into 16 bit words
        pAccelData->x = ((Buffer[1] << 8) | Buffer[2])>> 2;
        pAccelData->y = ((Buffer[3] << 8) | Buffer[4])>> 2;
        pAccelData->z = ((Buffer[5] << 8) | Buffer[6])>> 2;
    }
    else
    {
        // return with error
        return (I2C_ERROR);
    }

    // normal return
    return (I2C_OK);
}

```

---

## **4 Terminology**

### **4.1 Sensitivity**

The sensitivity is represented in LSB/g. In 2-g mode the sensitivity is 4096 LSB/g. In 4-g mode the sensitivity is 2048 LSB/ g and in 8-g mode the sensitivity is 1024 LSB/g.

### **4.2 Zero-g Offset**

Zero-g Offset describes the deviation of an actual output signal from the ideal output signal if the sensor is stationary. A sensor stationary on a horizontal surface will measure 0 g in X-axis and 0 g in Y-axis whereas the Z-axis will measure 1 g. A deviation from ideal value in this case is called Zero-g offset. Offset is to some extent a result of stress on the MEMS sensor and therefore the offset can slightly change after mounting the sensor onto a printed circuit board or exposing it to extensive mechanical stress.

### **4.3 Self-Test**

Self-Test can be used to verify the transducer functionality without applying an external mechanical stimulus. When Self-Test is activated, an electrostatic actuation force is applied to the sensor, simulating a small acceleration. In this case, the sensor outputs will exhibit a change in their DC levels which are related to the selected full scale through the device sensitivity. When Self-Test is activated, the device output level is given by the algebraic sum of the signals produced by the acceleration acting on the sensor and by the electrostatic self-test force.

## 5 Device Characteristics

### 5.1 Mechanical characteristics

Table 2. Mechanical characteristics @ VDD = 2.5 V, VDDIO = 1.8 V T = 25°C unless otherwise noted.

Parameter	Test Conditions	Symbol	Min	Typ	Max	Unit
Measurement range <sup>(1)</sup>	±2 g mode	FS <sub>ACC</sub>		±2		g
	±4 g mode			±4		
	±8 g mode			±8		
Sensitivity	±2 g mode	SEN <sub>ACC</sub>		4096		LSB/g
				0.244		mg/LSB
	±4 g mode			2048		LSB/g
				0.488		mg/LSB
	±8 g mode			1024		LSB/g
			0.976		mg/LSB	
Sensitivity change with temperature <sup>(1)</sup>	±2 g, ±4 g, ±8 g modes	TCS <sub>ACC</sub>		±0.01		%/°C
Sensitivity accuracy	@ 25°C	SEN-TOL <sub>ACC</sub>		±2.5		%SEN <sub>ACC</sub>
Zero-g level offset accuracy <sup>(2)</sup>	±2 g, ±4 g, ±8 g modes	OFF <sub>ACC</sub>		±20		mg
Zero-g level offset accuracy post-board mount <sup>(3)</sup>	±2 g, ±4 g, ±8 g modes	OFF-PBM <sub>ACC</sub>		±30		mg
Zero-g level change versus temperature	-40°C to 85°C <sup>(1)</sup>	TCO <sub>ACC</sub>		±0.2		mg/°C
Nonlinearity (deviation from straight line) <sup>(4)(5)</sup>	Over ±1 g range normal mode	NL <sub>ACC</sub>		±0.5		%FS <sub>ACC</sub>
Self-Test output change <sup>(6)</sup> X Y Z	Set to ±2 g mode	STOC <sub>ACC</sub>	+192 +270 +1275			LSB
Output noise density <sup>(4)(7)</sup>	ODR = 400 Hz, normal mode	ND <sub>ACC-NM</sub>		126		µg/√Hz
	ODR = 400 Hz, low-noise mode <sup>(1)</sup>	ND <sub>ACC-LNM</sub>		99		µg/√Hz
Operating temperature range		Top	-40		+85	°C

- Dynamic range is limited to ±4 g when in the low-noise mode.
- Before board mount.
- Post-board mount offset specifications are based on a 2-layer PCB design.
- Evaluation only.
- After post-board mount corrections for sensitivity, cross axis and offset. Refer to AN4399 for more information.
- Self-test is only exercised along one direction for each sensitive axis.
- Measured using earth's gravitational field (1 g) with the device oriented horizontally (+Z axis up) and stationary.

## 5.2 Electrical characteristics

**Table 3. Electrical characteristics @ VDD = 2.5 V, VDDIO = 1.8 V T = 25°C unless otherwise noted.**

Parameter	Test Conditions	Symbol	Min	Typ	Max	Unit
Supply voltage		VDD	1.95	2.5	3.6	V
Interface supply voltage		VDDIO	1.62	1.8	3.6	V
Low-power acceleration mode	ODR = 12.5 Hz	I <sub>ddACC-LPM</sub>		8		μA
	ODR = 100 Hz			35		
	ODR = 400 Hz			130		
Normal acceleration mode	ODR = 50 Hz	I <sub>ddACC-NM</sub>		35		μA
	ODR = 200 Hz			130		
	ODR = 800 Hz			240		
Current during boot sequence, 0.9 mS max duration using recommended regulator bypass capacitor	VDD = 2.5 V	I <sub>ddBOOT</sub>			3	mA
Value of capacitor on BYP pin	-40°C to 85°C	C <sub>BYP</sub>	75	100	470	nF
Standby mode current @ 25°C	Standby mode	I <sub>ddSTBY</sub>		2		μA
Standby mode current over-temperature range	Standby mode	I <sub>ddSTBY</sub>			10	μA
Digital high-level input voltage RST pin		V <sub>IHRST</sub>	1.04			V
Digital low-level input voltage RST pin		V <sub>ILRST</sub>			0.68	V
Digital high-level input voltage SCL, SDA, SA0, SA1		V <sub>IH</sub>	0.75*VDDIO			V
Digital low-level input voltage SCL, SDA, SA0, SA1		V <sub>IL</sub>			0.3*VDDIO	V
High-level output voltage INT1, INT2	I <sub>O</sub> = 500 μA	V <sub>OH</sub>	0.9*VDDIO			V
Low-level output voltage INT1, INT2	I <sub>O</sub> = 500 μA	V <sub>OL</sub>			0.1*VDDIO	V
Low-level output voltage SDA	I <sub>O</sub> = 500 μA	V <sub>OLSDA</sub>			0.1*VDDIO	V
SCL, SDA pin leakage	25°C			1.0		nA
	-40°C to 85°C			4.0		
SCL, SDA pin capacitance				3		pf
VDD rise time			0.001		1000	ms
Boot time <sup>(1)</sup>		T <sub>BOOT</sub>			1000	μs
Turn-on time 1 <sup>(2)</sup>		T <sub>POR→ACT</sub>		2/ODR + 2		ms
Turn-on time 2 <sup>(3)</sup>		T <sub>STBY→ACT</sub>		2/ODR + 1		ms
Operating temperature range		T <sub>OP</sub>	-40		+85	°C

1. Time from VDDIO on and VDD > VDD min until I<sup>2</sup>C/SPI interface ready for operation.

2. Time to obtain valid data from power-down mode to Active mode.

3. Time to obtain valid data from Standby mode to Active mode.

### 5.3 Absolute maximum ratings

Stresses above those listed as “absolute maximum ratings” may cause permanent damage to the device. This is a stress rating only and functional operation of the device under these conditions is not implied. Exposure to maximum rating conditions for extended periods may affect device reliability.

**Table 5. Maximum ratings**

Rating	Symbol	Value	Unit
Maximum acceleration (all axes, 100 $\mu$ s)	$g_{max}$	5,000	$g$
Supply voltage, IO voltage	$V_{DD_{max}}/$ $V_{DDIO_{max}}$	-0.3 to +3.6	V
Input voltage on any control pin (SA0/MISO, SA1/CS_B, SCL/SCLK, SDA/MOSI, RST)	$V_{IN_{max}}$	-0.3 to $V_{DDIO} + 0.3$	V
Drop-Test height	$D_{drop}$	1.8	m
Storage temperature range	$T_{STG}$	-40 to +125	$^{\circ}C$

**Table 6. ESD and latchup protection characteristics**

Rating	Symbol	Value	Unit
Human Body Model	HBM	$\pm 2000$	V
Machine Model	MM	$\pm 200$	V
Charge Device Model	CDM	$\pm 500$	V
Latchup current at $T = 85^{\circ}C$	$I_{LU}$	$\pm 100$	mA



This device is sensitive to mechanical shock. Improper handling can cause permanent damage to the part or cause the part to otherwise fail.



This device is sensitive to ESD, improper handling can cause permanent damage to the part.

# 6 Digital Interfaces

## 6.1 I<sup>2</sup>C interface characteristics

Table 7. I<sup>2</sup>C slave timing values<sup>(1)</sup>

Parameter	Symbol	I <sup>2</sup> C Fast Mode		Unit
		Min	Max	
SCL Clock Frequency	$f_{SCL}$	0	400	kHz
Bus Free Time between STOP and START condition	$t_{BUF}$	1.3		$\mu$ s
(Repeated) START Hold Time	$t_{HD;STA}$	0.6		$\mu$ s
(Repeated) START Setup Time	$t_{SU;STA}$	0.6		$\mu$ s
STOP Condition Setup Time	$t_{SU;STO}$	0.6		$\mu$ s
SDA Data Hold Time	$t_{HD;DAT}$	0.05	0.9 <sup>(2)</sup>	$\mu$ s
SDA Valid Time <sup>(3)</sup>	$t_{VD;DAT}$		0.9 <sup>(2)</sup>	$\mu$ s
SDA Valid Acknowledge Time <sup>(4)</sup>	$t_{VD;ACK}$		0.9 <sup>(2)</sup>	$\mu$ s
SDA Setup Time	$t_{SU;DAT}$	100		ns
SCL Clock Low Time	$t_{LOW}$	1.3		$\mu$ s
SCL Clock High Time	$t_{HIGH}$	0.6		$\mu$ s
SDA and SCL Rise Time	$t_r$	$20 + 0.1 C_b^{(5)}$	300	ns
SDA and SCL Fall Time	$t_f$	$20 + 0.1 C_b^{(5)}$	300	ns
Pulse width of spikes on SDA and SCL that must be suppressed by internal input filter	$t_{SP}$	0	50	ns

1. All values referred to VIH (min) and VIL (max) levels.
2. This device does not stretch the LOW period ( $t_{LOW}$ ) of the SCL signal.
3.  $t_{VD;DAT}$  = time for Data signal from SCL LOW to SDA output.
4.  $t_{VD;ACK}$  = time for Acknowledgement signal from SCL LOW to SDA output (HIGH or LOW, depending on which one is worse).
5.  $C_b$  = total capacitance of one bus line in pF.

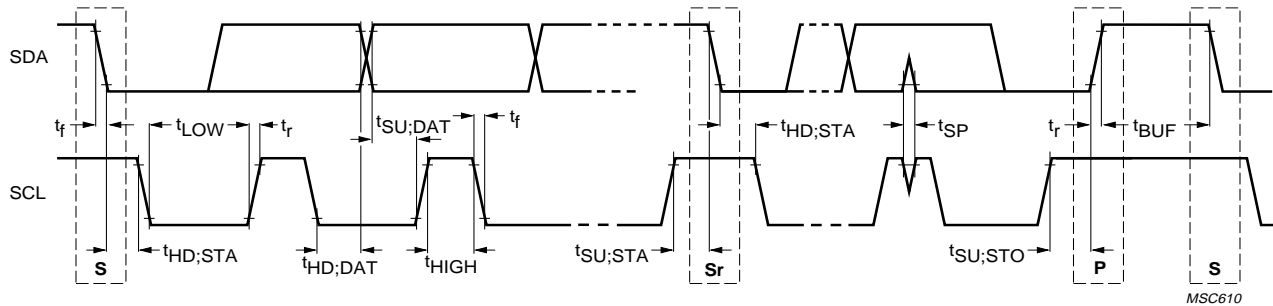

Figure 5. I<sup>2</sup>C slave timing diagram



### 6.1.1 General I<sup>2</sup>C operation

There are two signals associated with the I<sup>2</sup>C bus: the Serial Clock Line (SCL) and the Serial Data line (SDA). The latter is a bidirectional line used for sending and receiving the data to/from the interface. External pullup resistors connected to VDDIO are required for SDA and SCL. When the bus is free both the lines are high. The I<sup>2</sup>C interface is compliant with fast mode (400 kHz), and normal mode (100 kHz) I<sup>2</sup>C standards. Operation at frequencies higher than 400 kHz is possible, but depends on several factors including the pullup resistor values, and total bus capacitance (trace + device capacitance). See Table 8 for more information.

A transaction on the bus is started through a start condition (ST) signal, which is defined as a HIGH-to-LOW transition on the data line while the SCL line is held HIGH. After the ST signal has been transmitted by the master, the bus is considered busy. The next byte of data transmitted contains the slave address in the first seven bits, and the eighth bit, the read/write bit, indicates whether the master is receiving data from the slave or transmitting data to the slave. When an address is sent, each device in the system compares the first seven bits after the ST condition with its own address. If they match, the device considers itself addressed by the master. The 9th clock pulse, following the slave address byte (and each subsequent byte) is the acknowledge (ACK). The transmitter must release the SDA line during the ACK period. The receiver must then pull the data line low so that it remains stable low during the high period of the acknowledge clock period.

The number of bytes per transfer is unlimited. If a receiver can't receive another complete byte of data until it has performed some other function, it can hold the clock line, SCL low to force the transmitter into a wait state. Data transfer only continues when the receiver is ready for another byte and releases the data line. This delay action is called clock stretching. Not all receiver devices support clock stretching. Not all master devices recognize clock stretching. This part does not use clock stretching.

A low to high transition on the SDA line while the SCL line is high is defined as a stop condition (SP) signal. A write or burst write is always terminated by the master issuing the SP signal. A master should properly terminate a read by not acknowledging a byte at the appropriate time in the protocol. A master may also issue a repeated start signal (SR) during a transfer

The slave addresses that may be assigned to the FXLS8471Q part are 0x1C, 0x1D, 0x1E, or 0x1F. The selection is made through the logic level of the SA1 and SA0 inputs.

**Table 8. I<sup>2</sup>C slave address**

SA1	SA0	Slave address
0	0	0x1E
0	1	0x1D
1	0	0x1C
1	1	0x1F

### 6.1.2 I<sup>2</sup>C Read/Write operations

#### Single-byte read

The master (or MCU) transmits a start condition (ST) to the FXLS8471Q, followed by the slave address, with the R/W bit set to "0" for a write, and the FXLS8471Q sends an acknowledgement. Then the master (or MCU) transmits the address of the register to read and the FXLS8471Q sends an acknowledgement. The master (or MCU) transmits a repeated start condition (SR), followed by the slave address with the R/W bit set to "1" for a read from the previously selected register. The FXLS8471Q then acknowledges and transmits the data from the requested register. The master does not acknowledge (NAK) the transmitted data, but transmits a stop condition to end the data transfer.

#### Multiple-byte read

When performing a multi-byte or "burst" read, the FXLS8471Q automatically increments the register address read pointer after a read command is received. Therefore, after following the steps of a single-byte read, multiple bytes of data can be read from sequential registers after each FXLS8471Q acknowledgment (AK) is received until a no acknowledge (NAK) occurs from the master followed by a stop condition (SP) signaling an end of transmission.

#### Single-byte write

To start a write command, the master transmits a start condition (ST) to the FXLS8471Q, followed by the slave address with the R/W bit set to "0" for a write, and the FXLS8471Q sends an acknowledgement. Then the master (or MCU) transmits the address of the register to write to, and the FXLS8471Q sends an acknowledgement. Then the master (or MCU) transmits the 8-bit data to write to the designated register and the FXLS8471Q sends an acknowledgement that it has received the data. Since this transmission is complete, the master transmits a stop condition (SP) to end the data transfer. The data sent to the FXLS8471Q is now stored in the appropriate register.

## Multiple-byte write

The FXLS8471Q automatically increments the register address write pointer after a write command is received. Therefore, after following the steps of a single-byte write, multiple bytes of data can be written to sequential registers after each FXLS8471Q acknowledgment (ACK) is received.

### < Single-byte Read >

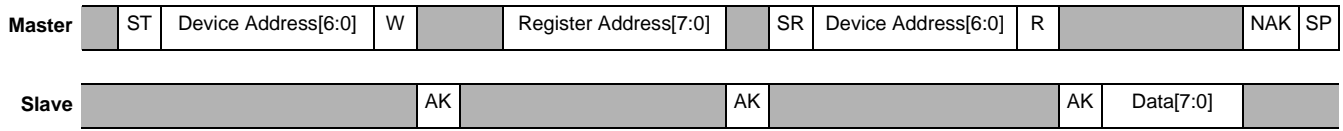

### < Multiple-byte Read >

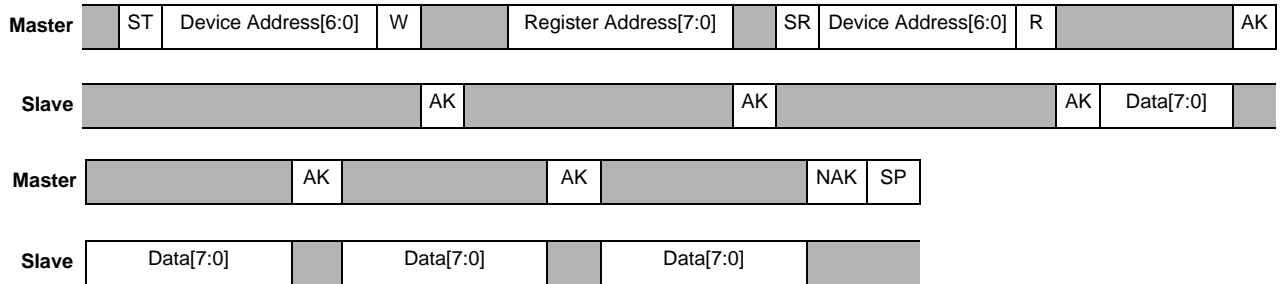

### < Multiple-byte Write >

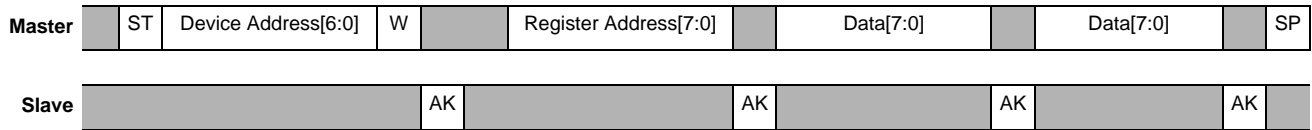

### < Single-byte Write >

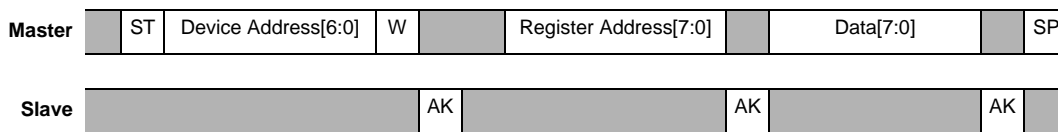

#### Legend

ST: Start Condition      SP: Stop Condition      NAK: No Acknowledge      W: Write = 0  
 SR: Repeated Start Condition      AK: Acknowledge      R: Read = 1

Figure 6. I<sup>2</sup>C timing diagram

## 6.2 SPI Interface characteristics

SPI interface is a classical master/slave serial port. The FXLS8471Q is always considered as the slave and thus is never initiating the communication.

Table 9 and Figure 7 describe the timing requirements for the SPI system.

**Table 9. SPI timing**

Function	Symbol	Min	Max	Unit
Operating Frequency	$f$	—	1	MHz
SCLK Period	$t_{SCLK}$	1000	—	ns
SCLK High time	$t_{CLKH}$	500	—	ns
SCLK Low time	$t_{CLKL}$	500	—	ns
CS_B lead time	$t_{SCS}$	65	—	ns
CS_B lag time	$t_{HCS}$	65	—	ns
MOSI data setup time	$t_{SET}$	25	—	ns
MOSI data hold time	$t_{HOLD}$	75	—	ns
MISO data valid (after SCLK low edge)	$t_{DDLY}$	—	500	ns
Width CS High	$t_{WCS}$	100	—	ns

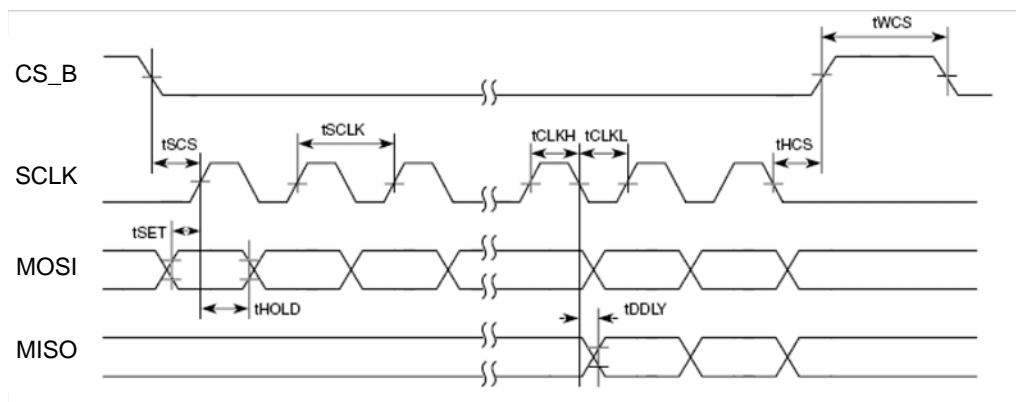

**Figure 7. SPI Timing Diagram**

### 6.2.1 General SPI operation

The CS\_B pin is driven low at the start of a SPI transaction, held low for the duration of the transaction, and driven high after the transaction is complete. During a transaction the master toggles the SPI clock (SCLK) and transmits data on the MOSI pin.

A write operation is initiated by transmitting a 1 for the R/W bit. Then the 8-bit register address, ADDR[7:0] is encoded in the first and second serialized bytes. Data to be written starts in the third serialized byte. The order of the bits is as follows:

Byte 0: R/W, ADDR[6], ADDR[5], ADDR[4], ADDR[3], ADDR[2], ADDR[1], ADDR[0],

Byte 1: ADDR[7], X, X, X, X, X, X, X,

Byte 2: DATA[7], DATA[6], DATA[5], DATA[4], DATA[3], DATA[2], DATA[1], DATA[0].

Multiple bytes of DATA may be transmitted. The X indicates a bit that is ignored by the part. The register address is auto-incremented so that the next clock edges will latch the data for the next register. When desired, the rising edge on CS\_B stops the SPI communication.

The FXLS8471Q SPI configuration is as follows:

- Polarity: rising/falling
- Phase: sample/setup
- Order: MSB first

Data is sampled during the rising edge of SCLK and set up during the falling edge of SCLK.

## 6.2.2 SPI READ/WRITE operations

A READ operation is initiated by transmitting a 0 for the R/W bit. Then the 8-bit register address, ADDR[7:0] is encoded in the first and second serialized bytes. Subsequent bits are ignored by the part. The read data is deserialized from the MISO pin.

Similarly a WRITE operation is initiated by transmitting a 1 for the R/W bit. After the first and second serialized bytes multiple-data bytes can be transmitted into consecutive registers, starting from the indicated register address in ADDR[7:0].

An SPI transaction is started by asserting the CS\_B pin (high-to-low transition), and ended by deasserting the CS\_B pin (low-to-high transition).

R/W bit followed by ADDR [6:0]	ADDR[7] followed by 7 "don't care" bits	Data0*	Data1	—	Datan
--------------------------------	---	--------	-------	---	-------

\* Data bytes must be transmitted to the slave (FXLS8471Q) using the MOSI pin by the master when R/W = 1. Data bytes will be transmitted by the slave (FXLS8471Q) to the master using the MISO pin when R/W = 0. The first 2 bytes are always transmitted by the master using the MOSI pin. That is, a transaction is always initiated by master. 1

**Figure 8. SPI single-burst READ/WRITE transaction diagram**

The registers embedded inside FXLS8471Q are accessed through either an I<sup>2</sup>C, or a SPI serial interface. To enable either interface the VDDIO line must be connected to the interface supply voltage. If VDD is not present and VDDIO is present FXLS8471Q is in shutdown mode and communications on the interface are ignored. If VDDIO is held high, VDD can be powered off and the communications pins will be in a high impedance state. This will allow communications to continue on the bus with other devices.

**Table 10. Serial interface pin descriptions**

Pin Name	Pin Description
VDDIO	Digital interface power
SA1/CS_B	I <sup>2</sup> C second least significant bit of device address/SPI chip select
SCL/SCLK	I <sup>2</sup> C/SPI serial clock
SDA/MOSI	I <sup>2</sup> C serial data/SPI master serial data out slave serial data in
SA0/MISO	I <sup>2</sup> C least significant bit of the device address/SPI master serial data in slave out

## 6.2.3 I<sup>2</sup>C/SPI auto detection

**Table 11. I<sup>2</sup>C/SPI auto detection**

SA0	Slave address
GND	I <sup>2</sup> C
VDDIO	I <sup>2</sup> C
Floating	SPI

FXLS8471Q employs an interface mode, auto-detection circuit that will select either I<sup>2</sup>C or SPI interface mode based on the state of the SA0 pin during power up or when exiting reset. Once set for I<sup>2</sup>C or SPI operation, the device will remain in I<sup>2</sup>C or SPI mode until the device is reset or powered down and the auto-detection process is repeated. Please note that when SPI interface mode is desired, care must be taken to ensure that no other slave device drives the common SA0/MISO pin during the 1 ms period after a hard or soft reset or powerup event.

## 6.2.4 Power supply sequencing and I<sup>2</sup>C/SPI mode auto-detection

FXLS8471Q does not have any specific power supply sequencing requirements between VDD and VDDIO voltage supplies to ensure normal operation. To ensure correct operation of the I<sup>2</sup>C/SPI auto-detection function, VDDIO should be applied before or at the same time as VDD. If this order cannot be maintained, the user should either toggle the RST line or power cycle the VDD rail in order to force the auto-detect function to restart and correctly identify the desired interface. FXLS8471Q will indicate completion of the reset sequence by toggling the INT1 pin from logic high to low to high over a 500 ns period. If the INT1 pin was already low prior to the reset event, it will only go high.

## 7 Modes of Operation

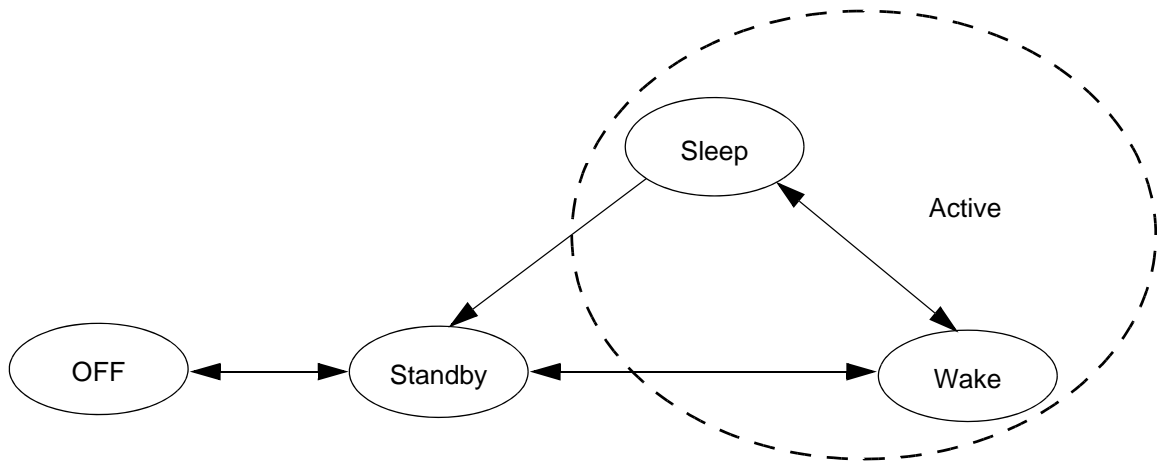

Figure 9. FXLS8471Q power mode transition diagram

Table 12. Mode of operation description

Mode	I <sup>2</sup> C/SPI Bus state	VDD	VDDIO	Function description
OFF	Powered down	<1.8 V	VDDIO can be > VDD	The device is powered off. All analog and digital blocks are shutdown. I <sup>2</sup> C bus inhibited.
Standby	I <sup>2</sup> C/SPI communication with FXLS8471Q is possible	ON	VDDIO = High VDD = High Active bit is cleared	Only digital blocks are enabled. Analog subsystem is disabled. Internal clocks disabled.
Active (Wake/Sleep)	I <sup>2</sup> C/SPI communication with FXLS8471Q is possible	ON	VDDIO = High VDD = High Active bit is set	All blocks are enabled (digital and analog).

All register contents are preserved when transitioning from Active to Standby mode, but some registers are reset when transitioning from Standby to Active. These registers are noted in [Table 13, "Register Address Map," on page 25](#). The Sleep and Wake modes are active modes. For more information on how to use the Sleep and Wake modes and configuring the device to transition between them, please refer to [Section 8, "Embedded Functionality"](#) or Freescale application note AN4074.

## 8 Embedded Functionality

FXLS8471Q is a low-power, digital output 3-axis acceleration sensor with both I<sup>2</sup>C and SPI interface options. Extensive embedded functionality is provided to detect inertial events at low power, with the ability to notify the host processor via either of the two programmable interrupt pins. The embedded functionality includes:

- 8-bit or 14-bit accelerometer data with an option for high-pass filtered output data
- Four different oversampling options for the output data. The oversampling settings allow the end user to optimize the resolution versus power consumption trade-off in a given application.
- A low-noise accelerometer mode that functions independently of the oversampling modes for even higher resolution
- Low-power auto-wake/sleep function for conserving power in portable battery powered applications
- Accelerometer pulse detection circuit which can be used to detect directional single and double taps
- Accelerometer directional motion and freefall event detection with programmable threshold and debounce time
- Acceleration transient detection with programmable threshold and debounce time. Transient detection can employ either a high-pass filter or use the difference between reference and current sample values.
- Orientation detection with programmable hysteresis for smooth transitions between portrait and landscape orientations
- Accelerometer vector-magnitude change event detection with programmable reference, threshold, and debounce time values

Many different configurations of the above functions are possible to suit the needs of the end application. Separate application notes are available to further explain the different configuration settings and potential use cases.

### 8.1 Factory calibration

FXLS8471Q is factory calibrated for sensitivity and offset on each axis. The trim values are stored in Non-Volatile Memory (NVM). On startup, the trim parameters are read from NVM and applied to the internal compensation circuitry. After mounting the device to the PCB, the user may further adjust the accelerometer offsets through the OFF\_X/Y/Z registers. For more information on accelerometer calibration, refer to Freescale application note AN4069.

### 8.2 8-bit or 14-bit data

The measured acceleration data is stored in the OUT\_X\_MSB, OUT\_X\_LSB, OUT\_Y\_MSB, OUT\_Y\_LSB, OUT\_Z\_MSB, and OUT\_Z\_LSB registers as 2's complement 14-bit numbers. The most significant 8-bits of each axis are stored in the OUT\_X, Y, Z\_MSB registers, so applications needing only 8-bit results simply read these three registers and ignore the OUT\_X, Y, Z\_LSB registers. To do this, the *f\_read* mode bit in CTRL\_REG1 must be set.

When the full-scale range is set to 2 *g*, the measurement range is -2 *g* to +1.999 *g*, and each count corresponds to 0.244 mg at ±14-bits resolution. When the full-scale is set to 8 *g*, the measurement range is -8 *g* to +7.996 *g*, and each count corresponds to 0.976 mg. The resolution is reduced by a factor of 64 if only the 8-bit results are used (CTRL\_REG1[*f\_read*] = 1). For further information on the different data formats and modes, please refer to Freescale application note AN4076.

### 8.3 Low-power modes versus high-resolution modes

FXLS8471Q can be optimized for lower power or higher resolution of the accelerometer output data. High resolution is achieved by setting the Inoise bit in register 0x2A. This improves the resolution (by lowering the noise), but be aware that the dynamic range becomes fixed at ±4 *g* when this bit is set. This will affect all internal embedded functions (scaling of thresholds, etc.) and reduce noise. Another method for improving the resolution of the data is through oversampling. One of the oversampling schemes of the output data can be activated when CTRL\_REG2[*mods*] = 2'b10 which will improve the resolution of the output data without affecting the internal embedded functions or fixing the dynamic range.

There is a trade-off between low power and high resolution. Low power can be achieved when the oversampling rate is reduced. When CTRL\_REG2[*mods*] = 2'b10, the lowest power is achieved, at the expense of higher noise. In general, the lower the selected ODR and OSR, the lower the power consumption. For more information on how to configure the device in low-power or high-resolution modes and understand the benefits and trade-offs, please refer to Freescale application note AN4075.

## 8.4 Auto-Wake/Sleep mode

FXLS8471Q can be configured to transition between sample rates (with their respective current consumptions) based on the status of the embedded interrupt event generators in the device. The advantage of using the Auto-Wake/Sleep is that the system can automatically transition to a higher sample rate (higher current consumption) when needed but spends the majority of the time in the Sleep mode (lower current) when the device does not require higher sampling rates. Auto-Wake refers to the device being triggered by one of the interrupt event functions to transition to a higher sample rate. This may also interrupt the processor to transition from a sleep mode to a higher power mode.

Sleep mode occurs when none of the enabled interrupt event functions has detected an interrupt within the user-defined, time-out period. The device will then transition to the specified lower sample rate. It may also alert the processor to go into a lower power mode to save power during this period of inactivity. Please refer to AN4074 for more detailed information on configuring the Auto-Wake/Sleep function.

## 8.5 Freefall and Motion event detection

FXLS8471Q integrates a programmable threshold based acceleration detection function capable of detecting either motion or freefall events depending upon the configuration. For further details and examples on using the embedded freefall and motion detection functions, please refer to Freescale application note AN4070.

### 8.5.1 Freefall detection

The detection of “Freefall” involves the monitoring of the X, Y, and Z axes for the condition where the acceleration magnitude is **below** a user-specified threshold for a user-definable amount of time. Typically, the usable threshold ranges are between  $\pm 100$  mg and  $\pm 500$  mg.

### 8.5.2 Motion detection

Motion detection is often used to alert the main processor that the device is currently in use. When the acceleration exceeds a set threshold for a set amount of time, the motion interrupt is asserted. A motion can be a fast moving shake or a slow moving tilt. This will depend on the threshold and timing values configured for the event. The motion detection function can analyze static acceleration changes or faster jolts. The timing value is set by a configurable debounce counter. The debounce counter acts like a filter to indicate whether the condition exists for longer than a set amount of time (that is, 100 ms or longer). There is also directional data available in the source register to detect the direction of the motion that generated the interrupt. This is useful for applications such as directional shake or flick detection, and can also assist gesture detection algorithms by indicating that a motion gesture has started.

## 8.6 Transient detection

FXLS8471Q integrates an acceleration transient detection function that incorporates a high-pass filter. Acceleration data goes through the high-pass filter, eliminating the DC tilt offset and low frequency acceleration changes. The high-pass filter cutoff can be set by the user to four different frequencies which are dependent on the selected Output Data Rate (ODR). A higher cutoff frequency ensures that DC and slowly changing acceleration data will be filtered out, allowing only the higher frequencies to pass. The transient detection feature can be used in the same manner as the motion detection by bypassing the high-pass filter. There is an option in the configuration register to do this. This adds more flexibility to cover the various customer use cases.

Many applications use the accelerometer’s static acceleration readings (that is, tilt) which measure the change in acceleration due to gravity only. These functions benefit from acceleration data being filtered with a low-pass filter where high-frequency data is considered noise. However, there are many functions where the accelerometer must analyze dynamic acceleration. Functions such as tap, flick, shake and step counting are based on the analysis of the change in the dynamic acceleration. The transient detection function can be routed to either interrupt pin through bit 5 in CTRL\_REG5 register (0x2E). Registers 0x1D – 0x20 are used for configuring the transient detection function. The source register contains directional data to determine the direction of the transient acceleration, either positive or negative. For further information of the embedded transient detection function along with specific application examples and recommended configuration settings, refer to Freescale application note AN4461.

## 8.7 Pulse detection

FXLS8471Q has embedded single/double and directional pulse detection. This function employs several timers for programming the pulse width time and the latency between pulses. The detection thresholds are independently programmable for each axis. The acceleration data input to the pulse detection circuit can be put through both high and low-pass filters, allowing for greater flexibility in discriminating between pulse and tap events. The PULSE\_SRC register provides information on the axis, direction (polarity), and single/double event status for the detected pulse or tap. For more information on how to configure the device for pulse detection, please refer to Freescale application note AN4072.

## 8.8 Orientation detection

FXLS8471Q has an embedded orientation detection algorithm with the ability to detect all six orientations. The transition angles and hysteresis are programmable, allowing for a smooth transition between portrait and landscape orientations.

The angle at which the device no longer detects the orientation change is referred to as the “Z-lockout angle”. The device operates down to 29° from the flat position. All angles are accurate to  $\pm 2^\circ$ .

For further information on the orientation detection function refer to Freescale application note, AN4068.

## 8.9 Acceleration Vector-Magnitude detection

FXLS8471Q incorporates an acceleration vector-magnitude change detection block that can be configured to generate an interrupt when the acceleration magnitude exceeds a preset threshold for a programmed debounce time. The function can be configured to operate in absolute or relative modes, and can also act as a wake to sleep/sleep to wake source. This function is useful for detecting acceleration transients when operated in absolute mode, or for detecting changes in orientation when operated in relative mode, refer to Freescale application note AN4692.



# 9 Register Map

Table 13. Register Address Map

Name	Type	Register Address	Auto-Increment Address				Default Hex Value	Comment
			STATUS[f_mode] = 00, CTRL_REG1[f_read] = 0	STATUS[f_mode] > 00, CTRL_REG1[f_read] = 0	STATUS[f_mode] = 00, CTRL_REG1[f_read] = 1	STATUS[f_mode] > 00, CTRL_REG1[f_read] = 1		
STATUS <sup>(1)(2)</sup>	R	0x00	0x01				0x00	Real-time, data-ready status or FIFO status (DR_STATUS or F_STATUS)
OUT_X_MSB <sup>(1)(2)</sup>	R	0x01	0x02	0x01	0x03	0x01	Data	[7:0] are 8 MSBs of 14-bit sample. Root pointer to XYZ FIFO data.
OUT_X_LSB <sup>(1)(2)</sup>	R	0x02	0x03		0x00		Data	[7:2] are 6 LSBs of 14-bit sample
OUT_Y_MSB <sup>(1)(2)</sup>	R	0x03	0x04		0x05	0x00	Data	[7:0] are 8 MSBs of 14-bit sample
OUT_Y_LSB <sup>(1)(2)</sup>	R	0x04	0x05		0x00		Data	[7:2] are 6 LSBs of 14-bit sample
OUT_Z_MSB <sup>(1)(2)</sup>	R	0x05	0x06		0x00		Data	[7:0] are 8 MSBs of 14-bit sample
OUT_Z_LSB <sup>(1)(2)</sup>	R	0x06	0x00		0x00		Data	[7:2] are 6 LSBs of 14-bit sample
Reserved	—	0x07-0x08	—				—	Reserved, do not modify
F_SETUP <sup>(1)(3)</sup>	R/W	0x09	0x0A				0x00	FIFO setup
TRIG_CFG	R/W	0x0A	0x0B				0x00	FIFO event trigger configuration register
SYSMOD <sup>(1)(2)</sup>	R	0x0B	0x0C				Output	Current system mode
INT_SOURCE <sup>(1)(2)</sup>	R	0x0C	0x0D				Output	Interrupt status
WHO_AM_I <sup>(1)</sup>	R	0x0D	0x0E				0x6A	Device ID
XYZ_DATA_CFG <sup>(1)(4)</sup>	R/W	0x0E	0x0F				0x00	Acceleration dynamic range and filter enable settings
HP_FILTER_CUTOFF <sup>(1)(4)</sup>	R/W	0x0F	0x10				0x00	Pulse detection high-pass and low-pass filter enable bits. High-pass filter cutoff frequency selection
PL_STATUS <sup>(1)(2)</sup>	R	0x10	0x11				0x00	Landscape/Portrait orientation status
PL_CFG <sup>(1)(4)</sup>	R/W	0x11	0x12				0x83	Landscape/Portrait configuration.
PL_COUNT <sup>(1)(3)</sup>	R/W	0x12	0x13				0x00	Landscape/Portrait debounce counter
PL_BF_ZCOMP <sup>(1)(4)</sup>	R/W	0x13	0x14				0x00	Back/Front Trip angle threshold
PL_THS_REG <sup>(1)(4)</sup>	R/W	0x14	0x15				0x1A	Portrait to Landscape Trip Threshold angle and hysteresis settings
A_FFMT_CFG <sup>(1)(4)</sup>	R/W	0x15	0x16				0x00	Freefall/Motion function configuration
A_FFMT_SRC <sup>(1)(2)</sup>	R	0x16	0x17				0x00	Freefall/Motion event source register
A_FFMT_THS <sup>(1)(3)</sup>	R/W	0x17	0x18				0x00	Freefall/Motion threshold register

**Table 13. Register Address Map (Continued)**

A_FFMT_COUNT <sup>(1)(3)</sup>	R/W	0x18	0x19	0x00	Freefall/Motion debounce counter
Reserved	—	0x19- 0x1C	—	—	Reserved, do not modify
TRANSIENT_CFG <sup>(1)(4)</sup>	R/W	0x1D	0x1E	0x00	Transient function configuration
TRANSIENT_SRC <sup>(1)(2)</sup>	R	0x1E	0x1F	0x00	Transient event status register
TRANSIENT_THS <sup>(1)(3)</sup>	R/W	0x1F	0x20	0x00	Transient event threshold
TRANSIENT_COUNT <sup>(1)(3)</sup>	R/W	0x20	0x21	0x00	Transient debounce counter
PULSE_CFG <sup>(1)(4)</sup>	R/W	0x21	0x22	0x00	Pulse function configuration
PULSE_SRC <sup>(1)(2)</sup>	R	0x22	0x23	0x00	Pulse function source register
PULSE_THSX <sup>(1)(3)</sup>	R/W	0x23	0x24	0x00	X-axis pulse threshold
PULSE_THSY <sup>(1)(3)</sup>	R/W	0x24	0x25	0x00	Y-axis pulse threshold
PULSE_THSZ <sup>(1)(3)</sup>	R/W	0x25	0x26	0x00	Z-axis pulse threshold
PULSE_TMLT <sup>(1)(4)</sup>	R/W	0x26	0x27	0x00	Time limit for pulse detection
PULSE_LTCY <sup>(1)(4)</sup>	R/W	0x27	0x28	0x00	Latency time for second pulse detection
PULSE_WIND <sup>(1)(4)</sup>	R/W	0x28	0x29	0x00	Window time for second pulse detection
ASLP_COUNT <sup>(1)(4)</sup>	R/W	0x29	0x2A	0x00	In activity counter setting for Auto-Sleep
CTRL_REG1 <sup>(1)(4)</sup>	R/W	0x2A	0x2B	0x00	System ODR, accelerometer OSR, operating mode
CTRL_REG2 <sup>(1)(4)</sup>	R/W	0x2B	0x2C	0x00	Self-Test, Reset, accelerometer OSR and Sleep mode settings
CTRL_REG3 <sup>(1)(4)</sup>	R/W	0x2C	0x2D	0x00	Sleep mode interrupt wake enable, interrupt polarity, push-pull/open- drain configuration
CTRL_REG4 <sup>(1)(4)</sup>	R/W	0x2D	0x2E	0x00	Interrupt enable register
CTRL_REG5 <sup>(1)(4)</sup>	R/W	0x2E	0x2F	0x00	Interrupt pin (INT1/INT2) map
OFF_X <sup>(1)(4)</sup>	R/W	0x2F	0x30	0x00	X-axis accelerometer offset adjust
OFF_Y <sup>(1)(4)</sup>	R/W	0x30	0x31	0x00	Y-axis accelerometer offset adjust
OFF_Z <sup>(1)(4)</sup>	R/W	0x31	0x32	0x00	Z-axis accelerometer offset adjust
Reserved	R/W	0x32- 0x5E	—	—	Reserved, do not modify
A_VECM_CFG	R/W	0x5F	0x60	0x00	Acceleration vector- magnitude configuration register
A_VECM_THS_MSB	R/W	0x60	0x61	0x00	Acceleration vector- magnitude threshold MSB

**Table 13. Register Address Map (Continued)**

A_VECM_THS_LSB	R/W	0x61	0x62	0x00	Acceleration vector-magnitude threshold LSB
A_VECM_CNT	R/W	0x62	0x63	0x00	Acceleration vector-magnitude debounce count
A_VECM_INITX_MSB	R/W	0x63	0x64	0x00	Acceleration vector-magnitude X-axis reference value MSB
A_VECM_INITX_LSB	R/W	0x64	0x65	0x00	Acceleration vector-magnitude X-axis reference value LSB
A_VECM_INITY_MSB	R/W	0x65	0x66	0x00	Acceleration vector-magnitude Y-axis reference value MSB
A_VECM_INITY_LSB	R/W	0x66	0x67	0x00	Acceleration vector-magnitude Y-axis reference value LSB
A_VECM_INITZ_MSB	R/W	0x67	0x68	0x00	Acceleration vector-magnitude Z-axis reference value MSB
A_VECM_INITZ_LSB	R/W	0x68	0x69	0x00	Acceleration vector-magnitude Z-axis reference value LSB
Reserved	—	0x69-0x72	—	—	Reserved, do not modify
A_FFMT_THS_X_MSB	R/W	0x73	0x74	0x00	X-axis FFMT threshold MSB
A_FFMT_THS_X_LSB	R/W	0x74	0x75	0x00	X-axis FFMT threshold LSB
A_FFMT_THS_Y_MSB	R/W	0x75	0x76	0x00	Y-axis FFMT threshold MSB
A_FFMT_THS_Y_LSB	R/W	0x76	0x77	0x00	Y-axis FFMT threshold LSB
A_FFMT_THS_Z_MSB	R/W	0x77	0x78	0x00	Z-axis FFMT threshold MSB
A_FFMT_THS_Z_LSB	R/W	0x78	0x79	0x00	Z-axis FFMT threshold LSB
Reserved	—	0x79 - 0xFF	—	—	Reserved, do not modify

1. Register contents are preserved when transitioning from Active to Standby mode.
2. Register contents are reset when transitioning from Standby to Active mode.
3. Register contents can be modified anytime in Standby or Active mode. A write to this register will cause a reset of the corresponding internal system debounce counter.
4. Modification of this register's contents can only occur when device is in Standby mode, except the FS[1:0] bit fields in CTRL\_REG1 register.

**NOTE**

The auto-increment addressing is only enabled when registers are read using burst-read mode when the device is configured for I<sup>2</sup>C or SPI. The auto-increment address is automatically reset to 0x00 in I<sup>2</sup>C mode when a stop condition is detected. In SPI mode there is no stop condition and the auto-increment address is not automatically reset to 0x00.

## 10 Registers by Functional Blocks

### 10.1 Device configuration

#### 10.1.1 STATUS (0x00) register

Table 14. STATUS register

DR_STATUS or F_STATUS							
0	0	0	0	0	0	0	0

Table 15. STATUS Description

Field	Description
F_SETUP[f_mode] = 2'b00	register 0x00 → DR_STATUS
F_SETUP[f_mode] > 2'b00	register 0x00 → F_STATUS

The STATUS register aliases allow for the contiguous burst read of both status and current acceleration sample/FIFO data using the auto-increment addressing mechanism in both 8- and 14-bit modes.

#### 10.1.2 DR\_STATUS (0x00) register

Data-Ready Status when F\_SETUP[f\_mode] = 0x00

This STATUS register provides the acquisition status information on a per-sample basis, and reflects real-time updates to the OUT\_X, OUT\_Y, and OUT\_Z registers.

When the FIFO subsystem data output register driver is disabled (F\_SETUP[f\_mode] = 2'b00), this register indicates the real-time status information of the accelerometer X, Y, and Z axes sample data.

Table 16. DR\_STATUS register

zyxow	zow	yow	xow	zyxdr	zdr	ydr	xdr
0	0	0	0	0	0	0	0

Table 17. DR\_STATUS description

Field	Description
zyxow	zyxow is set to 1 whenever new data is acquired before completing the retrieval of the previous set. This event occurs when the content of at least one acceleration data register (that is, OUT_X, OUT_Y, and OUT_Z) has been overwritten. zyxow is cleared when the high-bytes of the acceleration data (OUT_X_MSB, OUT_Y_MSB, and OUT_Z_MSB) are read. X, Y, Z-axis data overwrite. 0: No data overwrite has occurred 1: Previous X, Y, Z data was overwritten by new X, Y, Z data before it was completely read
zow	zow is set to 1 whenever a new Z-axis acquisition is completed before the retrieval of the previous data. When this occurs the previous data is overwritten. zow is cleared anytime OUT_Z_MSB register is read. Z-axis data overwrite. 0: No data overwrite has occurred 1: Previous Z-axis data was overwritten by new Z-axis data before it was read
yow	yow is set to 1 whenever a new Y-axis acquisition is completed before the retrieval of the previous data. When this occurs the previous data is overwritten. yow is cleared anytime OUT_Y_MSB register is read. Y-axis data overwrite. 0: No data overwrite has occurred 1: Previous Y-axis data was overwritten by new Y-axis data before it was read
xow	xow is set to 1 whenever a new X-axis acquisition is completed before the retrieval of the previous data. When this occurs the previous data is overwritten. xow is cleared anytime OUT_X_MSB register is read. X-axis data overwrite. 0: No data overwrite has occurred 1: Previous X-axis data was overwritten by new X-axis data before it was read

**Table 17. DR\_STATUS description (Continued)**

zyxdr	zyxdr signals that a new acquisition for any of the enabled channels is available. zyxdr is cleared when the high-bytes of the acceleration data (OUT_X_MSB, OUT_Y_MSB, OUT_Z_MSB) are read. X, Y, Z-axis new data ready. 0: No new set of data ready 1: New set of data is ready
zdr	zdr is set to 1 whenever a new Z-axis data acquisition is completed. zdr is cleared anytime the OUT_Z_MSB register is read. Z-axis new data available. 0: No new Z-axis data is ready 1: New Z-axis data is ready
ydr	ydr is set to 1 whenever a new Y-axis data acquisition is completed. ydr is cleared anytime the OUT_Y_MSB register is read. Y-axis new data available. Default value: 0 0: No new Y-axis data ready 1: New Y-axis data is ready
xdr	xdr is set to 1 whenever a new X-axis data acquisition is completed. xdr is cleared anytime the OUT_X_MSB register is read. X-axis new data available. Default value: 0 0: No new X-axis data ready 1: New X-axis data is ready

### 10.1.3 F\_STATUS (0x00) register

FIFO Status when F\_SETUP[f\_mode] = 0x00 > 0x00.

If the FIFO subsystem data output register driver is enabled, the status register indicates the current status information of the FIFO subsystem.

**Table 18. F\_STATUS register**

f_ovf	f_wmrk_flag	f_cnt[5:0]
0	0	0

**Table 19. FIFO flag event descriptions**

f_ovf	f_wmrk_flag	Event description
0	X	No FIFO overflow events detected.
1	X	FIFO overflow event detected.
X	0	No FIFO watermark event detected.
X	1	A FIFO Watermark event was detected indicating that a FIFO sample count greater than watermark value has been reached. If F_SETUP[f_mode] = 2'b11, a FIFO trigger event was detected

The *f\_ovf* and *f\_wmrk\_flag* flags remain asserted while the event source is still active, but the user can clear the FIFO interrupt bit in the interrupt source register (INT\_SOURCE) by reading the F\_STATUS register. In this case, the INT\_SOURCE[src\_fifo] bit will be set again when the next data sample enters the FIFO.

Therefore the *f\_ovf* bit will remain asserted while the FIFO has overflowed and the *f\_wmrk\_flag* bit will remain asserted while the *f\_cnt* value is equal to or greater than then *f\_wmrk* value.

**Table 20. FIFO sample count bit description**

Field	Description
f_cnt[5:0]	These bits indicate the number of acceleration samples currently stored in the FIFO buffer. Count 6'b000000 indicates that the FIFO is empty. FIFO sample counter. Default value 6'b000000. (6'b000001 to 6'b100000 indicates 1 to 32 samples stored in FIFO

### 10.1.4 TRIG\_CFG (0x0A) register

FIFO trigger configuration register. After the interrupt flag of the enabled event in TRIG\_CFG is set, the FIFO (when configured in Trigger mode) is gated at the time of the interrupt event preventing the further collection of data samples. This allows the host processor to analyze the data leading up to the event detection (up to 32 samples). For detailed information on how to utilize the FIFO and the various trigger events, please see AN4073 available on the Freescale website.

**Table 21. TRIG\_CFG register**

—	—	trig_trans	trig_Indprt	trig_pulse	trig_ffmt	trig_a_vecm	—
0	0	0	0	0	0	0	0

**Table 22. TRIG\_CFG bit descriptions**

Field	Description
trig_trans	Transient interrupt FIFO trigger enable.
trig_Indprt	Landscape/Portrait orientation interrupt FIFO trigger enable.
trig_pulse	Pulse interrupt FIFO trigger enable
trig_ffmt	Freefall/motion interrupt FIFO trigger enable
trig_a_vecm	Acceleration vector-magnitude FIFO trigger enable.

### 10.1.5 SYSMOD (0x0B) register

**Table 23. SYSMOD register**

fgerr	fgt[4:0]	sysmod[1:0]
-------	----------	-------------

**Table 24. SYSMOD bit description**

Field	Description
fgerr	FIFO gate error. Default value: 0. 0: No FIFO gate error detected. 1: FIFO gate error was detected. Emptying the FIFO buffer clears the <i>fgerr</i> bit in the SYSMOD register. See CTRL_REG3 [Interrupt CTRL register] (0x2C) for more information on configuring the FIFO Gate function.
fgt[4:0]	Number of ODR time units since <i>fgerr</i> was asserted. Reset when <i>fgerr</i> is cleared
sysmod[1:0]	System mode. Default value: 0. 00: Standby mode 01: Wake mode 10: Sleep mode

The system mode register indicates the current device operating mode. Applications using the Auto-Sleep/Auto-Wake mechanism should use this register to synchronize their application with the device operating mode. The system mode register also indicates the status of the FIFO gate error flag and the time elapsed since the FIFO gate error flag was asserted.

## 10.1.6 INT\_SOURCE (0x0C) register

Interrupt source register. The bits that are set (logic '1') indicate which function has asserted its interrupt and conversely bits that are cleared (logic '0') indicate which function has not asserted its interrupt.

Reading the INT\_SOURCE register does not clear any interrupt status bits (except for src\_a\_vecm, see below); the respective interrupt flag bits are reset by reading the appropriate source register for the function that generated the interrupt.

**Table 25. INT\_SOURCE register**

src_aslp	src_fifo	src_trans	src_Indprt	src_pulse	src_ffmt	src_a_vecm	src_drdy
----------	----------	-----------	------------	-----------	----------	------------	----------

**Table 26. INT\_SOURCE bit descriptions**

Field	Description
src_aslp	Auto-Sleep/Wake interrupt status bit: logic '1' indicates that an interrupt event that can cause a Wake to Sleep or Sleep to Wake system mode transition has occurred and logic '0' indicates that no Wake to Sleep or Sleep to Wake system mode transition interrupt event has occurred. The "Wake-to-Sleep" transition occurs when a period of inactivity that exceeds the user-specified time limit (ASLP_COUNT) has been detected, thus causing the system to transition to a user-specified low ODR setting. A "Sleep-to-Wake" transition occurs when the user-specified interrupt event has awakened the system, thus causing the system to transition to the user-specified higher ODR setting. Reading the SYSMOD register will clear the <i>src_aslp</i> bit.
src_fifo	FIFO interrupt status bit: logic '1' indicates that a FIFO interrupt event such as an overflow or watermark (F_STATUS[f_cnf] = F_STATUS[f_wmrk]) event has occurred and logic '0' indicates that no FIFO interrupt event has occurred. This bit is cleared by reading the F_STATUS register.
src_trans	Transient interrupt status bit: logic '1' indicates that an acceleration transient value greater than user-specified threshold has occurred. and logic '0' indicates that no transient event has occurred. This bit is asserted whenever TRANSIENT_SRC[ea] is asserted and the functional block interrupt has been enabled. This bit is cleared by reading the TRANSIENT_SRC register.
src_Indprt	Landscape/Portrait orientation interrupt status bit: logic '1' indicates that an interrupt was generated due to a change in the device orientation status and logic '0' indicates that no change in orientation status was detected. This bit is asserted whenever PL_STATUS[new/p] is asserted and the functional block interrupt has been enabled. This bit is cleared by reading the PL_STATUS register.
src_pulse	Pulse interrupt status bit: logic '1' indicates that an interrupt was generated due to single- and/or double- pulse event and logic '0' indicates that no pulse event was detected. This bit is asserted whenever PULSE_SRC[ea] is asserted and the functional block interrupt has been enabled. This bit is cleared by reading the PULSE_SRC register.
src_ffmt	Freefall/motion interrupt status bit: logic '1' indicates that the freefall/motion function interrupt is active and logic '0' indicates that no freefall or motion event was detected. This bit is asserted whenever PULSE_SRC[ea] is asserted and the functional block interrupt has been enabled. This bit is cleared by reading the A_FFMT_SRC register.
src_a_vecm	Accelerometer vector-magnitude interrupt status bit: logic '1' indicates that an interrupt was generated due to acceleration vector-magnitude function and logic '0' indicates that no interrupt has been generated. This bit is cleared by reading this register (INT_SOURCE).
src_drdy	Data-ready interrupt status bit. In acceleration only mode this bit indicates that new accelerometer data is available to read. The <i>src_drdy</i> interrupt flag is cleared by reading out the acceleration data from the OUT_X, OUT_Y, and OUT_Z registers. This data can be burst read using a 6-byte burst read starting from the address 0x01 (OUT_X_MSB).

### 10.1.7 WHO\_AM\_I (0x0D) register

**Table 27. WHO\_AM\_I register**

who_am_i[7:0]
0x6A

Device identification register. This register contains the device identifier which is set to 0x6A.

### 10.1.8 CTRL\_REG1 (0x2A) register

#### NOTE

Except for Standby mode selection, the device must be in Standby mode to change any of the fields within CTRL\_REG1 (0x2A).

**Table 28. CTRL\_REG1 register**

aslp_rate[1:0]	dr[2:0]	Inoise	f_read	active
0	3'b001	0	0	0

**Table 29. CTRL\_REG1 bit descriptions**

Field	Description
aslp_rate[1:0]	Configures the auto-wake sample frequency when the device is in Sleep mode. See <a href="#">Table 30</a> for more information.
dr[2:0]	Output Data Rate (ODR) selection. See <a href="#">Table 31</a> for more information.
Inoise	Reduced noise and full-scale range mode (analog gain times 2). 0: Normal mode 1: Reduced noise mode; Note that the FSR setting is restricted to a $\pm 4 g$ in this mode (Inoise = 1).
f_read	Fast-read mode: Data format is limited to the 8-bit MSB for accelerometer output data. The auto-address pointer will skip over the LSB addresses for each axes sample data when performing a burst read operation. 0: Normal mode 1: Fast-read mode
active	Standby/Active. 0: Standby mode 1: Active mode

**Table 30. Sleep mode poll rate description**

aslp_rate1	aslp_rate0	Frequency (Hz)
0	0	50
0	1	12.5
1	0	6.25
1	1	1.56

It is important to note that when the device is in Auto-Sleep mode, the system ODR and data rate for all the system functional blocks is overridden by the sleep data rate set by the aslp\_rate field..

[Table 31](#) shows the various system output data rates (ODR) that may be selected using the dr[2:0] bits.



**Table 31. System Output Data Rate selection**

dr2	dr1	dr0	ODR (Hz)	Period (ms)
0	0	0	800.0	1.25
0	0	1	400.0	2.5
0	1	0	200.0	5
0	1	1	100.0	10
1	0	0	50.0	20
1	0	1	12.5	80
1	1	0	6.25	160
1	1	1	1.5625	640

The *active* bit selects between Standby mode and Active mode. The default value is 0 (Standby mode) on reset.

The *lnoise* bit selects between normal full dynamic range mode and a high sensitivity, low-noise mode. In low-noise mode the maximum signal that can be measured is  $\pm 4$  g. Note: Any thresholds set above 4 g will not be reached.

The *f\_read* bit selects between normal and fast-read modes where the auto-increment counter will also skip over the LSB data bytes when *f\_read* = 1. All of the acceleration data MSB's can be read out with a single 3-byte burst read starting at the OUT\_X\_MSB register when *f\_read* = 1.

**NOTE**

The *f\_read* bit can only be changed while F\_SETUP[*f\_mode*] = 0.

**10.1.9 CTRL\_REG2 (0x2B) register**

**Table 32. CTRL\_REG2 register**

st	rst	—	smods[1:0]	slpe	mods[1:0]
0	0	0	0	0	0

**Table 33. CTRL\_REG2 bit descriptions**

Field	Description
st	The <i>st</i> bit activates the accelerometer self-test function. When <i>st</i> is set to 1, a change will occur in the device output levels for each axis, allowing the host application to check the functionality of the transducer and measurement signal chain. Self-Test Enable: 0: Self-Test disabled 1: Self-Test enabled.
rst	The <i>rst</i> bit is used to initiate a software reset. The reset mechanism can be enabled in both Standby and Active modes. When the <i>rst</i> bit is set, the boot mechanism resets all functional block registers and loads the respective internal registers with their default values. Note that the current revision of FXLS8471Q silicon, as identified by a WHO_AM_I value of 0x6A, has an errata associated with the software reset mechanism when the device is operated in SPI mode. Refer to <a href="#">Appendix A.1</a> for further information and a suggested work-around. After setting the <i>rst</i> bit, the system will automatically transition to Standby mode. Therefore, if the system was already in Standby mode, the reboot process will immediately begin; else if the system was in Active mode the boot mechanism will automatically transition the system from Active mode to Standby mode, only then can the reboot process begin. A system reset can also be initiated by pulsing the external RST pin high. The I <sup>2</sup> C and SPI communication systems are also reset to avoid corrupted data transactions. The host application should allow 1 ms between issuing a software (setting <i>rst</i> bit) or hardware (pulsing RST pin) reset and attempting communications with the device over the I <sup>2</sup> C or SPI interfaces. When the SPI interface mode is desired and multiple devices are present on the bus, make sure that the bus is quiet (all slave device MISO pins are high-z) during this 1 ms period to ensure the device does not inadvertently enter I <sup>2</sup> C mode. See <a href="#">Section 6.2.3</a> for further information about the interface mode auto-detection circuit. At the end of the boot process, the <i>rst</i> bit is hardware cleared. 0: Device reset disabled 1: Device reset enabled.
smods[1:0]	Sleep mode power scheme selection. See <a href="#">Table 34</a> for more information.
slpe <sup>(1)</sup>	Auto-Sleep mode enable: 0: Auto-Sleep is not enabled 1: Auto-Sleep is enabled.
mods[1:0]	Accelerometer OSR selection. This setting, along with the ODR selection determines the Active mode power and RMS noise for acceleration measurements. See <a href="#">Table 34</a> for more information.

1. When SLPE = 1, a transition between Sleep mode and Wake mode results in a FIFO flush and a reset of internal functional block counters. All functional block status information is preserved except where otherwise indicated. For further information, refer to the CTRL\_REG3 register description (*fifo\_gate* bit).

**Table 34. CTRL\_REG2[mods] oversampling modes**

(s)mods1	(s)mods0	Power mode
0	0	Normal
0	1	Low Noise, Low Power
1	0	High Resolution
1	1	Low Power

**Table 35. Oversampling Ratio versus oversampling mode**

Accelerometer OSR				
ODR (Hz)	Normal	Low Noise, Low Power	High Resolution	Low Power
1.5625	128	32	1024	16
6.25	32	8	256	4
12.5	16	4	128	2
50	4	4	32	2
100	4	4	16	2
200	4	4	8	2
400	4	4	4	2
800	2	2	2	2

## 10.1.10 CTRL\_REG3 [Interrupt Control Register] (0x2C) register

**Table 36. CTRL\_REG3 register**

fifo_gate	wake_trans	wake_Indprt	wake_pulse	wake_ffmt	wake_en_a_vecm	ipol	pp_od
0	0	0	0	0	0	0	0

**Table 37. CTRL\_REG3 bit descriptions**

Field	Description
fifo_gate	<p>0: FIFO gate is bypassed. FIFO is flushed upon the system mode transitioning from Wake-to-Sleep mode or from Sleep-to-Wake mode.</p> <p>1: The FIFO input buffer is blocked when transitioning from "Wake-to-Sleep" mode or from "Sleep-to-Wake" mode until the FIFO is flushed.<sup>(1)</sup> Although the system transitions from "Wake-to-Sleep" or from "Sleep-to-Wake" the contents of the FIFO buffer are preserved, new data samples are ignored until the FIFO is emptied by the host application. If the <i>fifo_gate</i> bit is set to logic '1' and the FIFO buffer is not emptied before the arrival of the next sample, then the SYSMOD[fgerr] will be asserted. The SYSMOD[fgerr] bit remains asserted as long as the FIFO buffer remains un-emptied.</p> <p>Emptying the FIFO buffer clears the SYS_MOD[fgerr] register.</p>
wake_tran	<p>0: Transient function is disabled in Sleep mode</p> <p>1: Transient function is enabled in Sleep mode and can generate an interrupt to wake the system</p>
wake_Indprt	<p>0: Orientation function is disabled Sleep mode.</p> <p>1: Orientation function is enabled in Sleep mode and can generate an interrupt to wake the system</p>
wake_pulse	<p>0: Pulse function is disabled in Sleep mode</p> <p>1: Pulse function is enabled in Sleep mode and can generate an interrupt to wake the system</p>
wake_ffmt	<p>0: Freefall/motion function is disabled in Sleep mode</p> <p>1: Freefall/motion function is enabled in Sleep mode and can generate an interrupt to wake the system</p>
wake_en_a_vecm	<p>0: Acceleration vector-magnitude function is disabled in Sleep mode</p> <p>1: Acceleration vector-magnitude function is enabled in Sleep mode and can generate an interrupt to wake the system</p>
ipol	<p>The <i>ipol</i> The bit selects the logic polarity of the interrupt signals output on the INT1 and INT2 pins.</p> <p>INT1/INT2 interrupt logic polarity:</p> <p>0: Active low (default)</p> <p>1: Active high</p>
pp_od	<p>INT1/INT2 push-pull or open-drain output mode selection. The open-drain configuration can be used for connecting multiple interrupt signals on the same interrupt line but will require an external pullup resistor to function correctly.</p> <p>0: Push-pull (default)</p> <p>1: Open-drain</p>

1. The FIFO contents are flushed whenever the system ODR changes in order to prevent the mixing of FIFO data from different ODR periods.

### 10.1.11 CTRL\_REG4 [Interrupt Enable Register] (0x2D) register

**Table 38. CTRL\_REG4 register**

int_en_aslp	int_en_fifo	int_en_trans	int_en_Indprt	int_en_pulse	int_en_ffmt	int_en_a_vecm	int_en_drdy
0	0	0	0	0	0	0	0

**Table 39. Interrupt Enable Register bit descriptions**

Field	Description
int_en_aslp	Sleep interrupt enable 0: Auto-Sleep/Wake interrupt disabled 1: Auto-Sleep/Wake interrupt enabled
int_en_fifo	FIFO interrupt enable 0: FIFO interrupt disabled 1: FIFO interrupt enabled
int_en_trans	Transient interrupt enable 0: Transient interrupt disabled 1: Transient interrupt enabled
int_en_Indprt	Orientation interrupt enable 0: Orientation (Landscape/Portrait) interrupt disabled 1: Orientation (Landscape/Portrait) interrupt enabled
int_en_pulse	Pulse interrupt enable 0: Pulse detection interrupt disabled 1: Pulse detection interrupt enabled
int_en_ffmt	Freefall/motion interrupt enable 0: Freefall/motion interrupt disabled 1: Freefall/motion interrupt enabled
int_en_a_vecm	Acceleration vector-magnitude interrupt enable 0: Acceleration vector-magnitude interrupt disabled 1: Acceleration vector-magnitude interrupt enabled
int_en_drdy	Data-ready interrupt enable 0: Data-ready interrupt disabled 1: Data-ready interrupt enabled

The corresponding functional block interrupt enable bit allows the functional block to route its event detection flag to the system's interrupt controller. The interrupt controller routes the enabled interrupt signals to either the INT1 or INT2 pins depending on the settings made in CTRL\_REG5.

## 10.1.12 CTRL\_REG5 [Interrupt Routing Configuration Register] (0x2E) register

**Table 40. CTRL\_REG5 register**

int_cfg_aslp	int_cfg_fifo	int_cfg_trans	int_cfg_Indprt	int_cfg_pulse	int_cfg_ffmt	int_cfg_a_vecm	int_cfg_drdy
0	0	0	0	0	0	0	0

**Table 41. Interrupt Routing Configuration bit descriptions**

Field	Description
int_cfg_aslp	Sleep interrupt routing 0: Interrupt is routed to INT2 pin 1: Interrupt is routed to INT1 pin
int_cfg_fifo	FIFO interrupt routing 0: Interrupt is routed to INT2 pin 1: Interrupt is routed to INT1 pin
int_cfg_trans	Transient detection interrupt routing 0: Interrupt is routed to INT2 pin 1: Interrupt is routed to INT1 pin
int_cfg_Indprt	Orientation detection interrupt routing 0: Interrupt is routed to INT2 pin 1: Interrupt is routed to INT1 pin
int_cfg_pulse	Pulse detection interrupt routing 0: Interrupt is routed to INT2 pin 1: Interrupt is routed to INT1 pin
int_cfg_ffmt	Freefall/motion detection interrupt routing 0: Interrupt is routed to INT2 pin 1: Interrupt is routed to INT1 pin
int_cfg_a_vecm	Acceleration vector-magnitude interrupt routing 0: Interrupt is routed to INT2 pin 1: Interrupt is routed to INT1 pin.
int_cfg_drdy	INT1/INT2 configuration. 0: Interrupt is routed to INT2 pin 1: Interrupt is routed to INT1 pin.

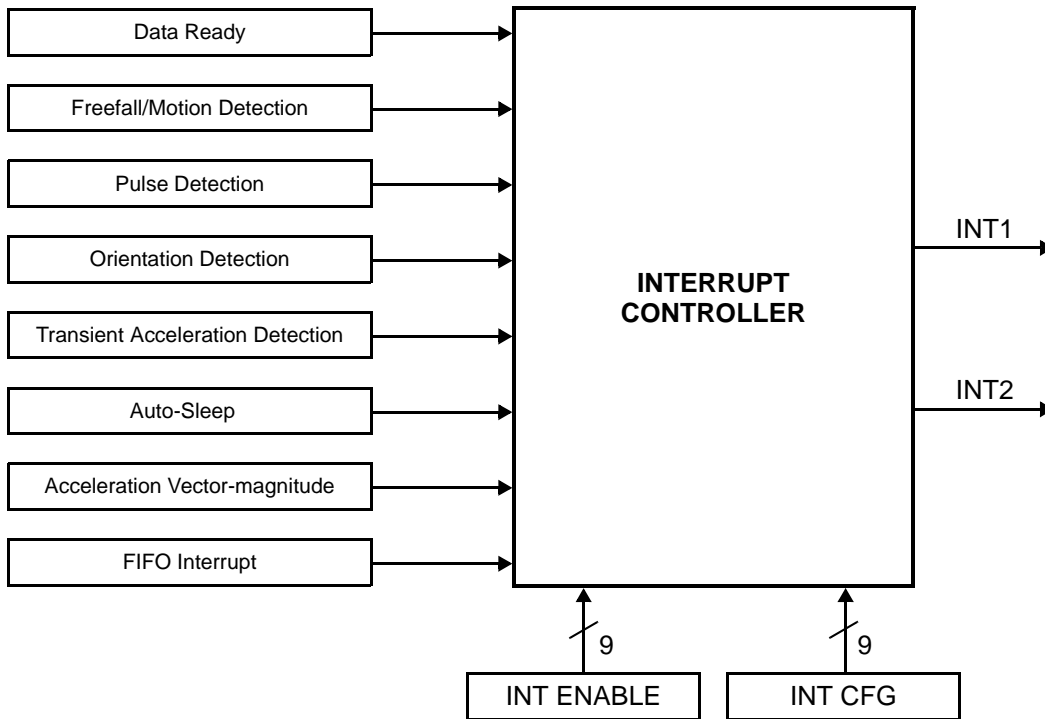

**Figure 10. Interrupt controller block diagram**

The system's interrupt controller uses the corresponding bit field in the CTRL\_REG5 register to determine the routing for the INT1 and INT2 interrupt pins. For example, if the *int\_cfg\_drdy* bit value is logic '0' the functional block's interrupt is routed to INT2, and if the bit value is logic '1' then the interrupt is routed to INT1. All interrupt signals routed to either INT1 or INT2 are logically OR'ed together as illustrated in Figure 11, thus one or more functional blocks can assert an interrupt pin simultaneously; therefore a host application responding to an interrupt should read the INT\_SOURCE register to determine the source(s) of the interrupt(s).

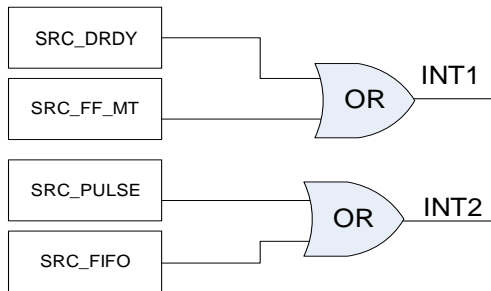

**Figure 11. INT1/INT2 PIN Control Logic**

## 10.2 Auto-Sleep trigger

### 10.2.1 ASLP\_COUNT (0x29) register

The ASLP\_COUNT register sets the minimum time period of event flag inactivity required to initiate a change from the current active mode ODR value specified in CTRL\_REG1[*dr*] to the Sleep mode ODR value specified in CTRL\_REG1[*aslp\_rate*], provided that CTRL\_REG2[*s/pe*] = 1.

See [Table 45](#) for functional blocks that may be monitored for inactivity in order to trigger the return-to-sleep event.

**Table 42. ASLP\_COUNT register**

aslp_cnt[7:0]
8'b00000000

**Table 43. ASLP\_COUNT bit description**

Field	Description
aslp_cnt[7:0]	See <a href="#">Table 44</a> for details

**Table 44. ASLP\_COUNT relationship with ODR**

Output Data Rate (ODR)	Maximum inactivity time (s)	ODR time step (ms)	ASLP_COUNT step (ms)
800	81	1.25	320
400	81	2.5	320
200	81	5	320
100	81	10	320
50	81	20	320
12.5	81	80	320
6.25	81	160	320
1.56	63	640	640

**Table 45. Sleep/Wake mode gates and triggers**

Interrupt source	Event restarts time and delays Return-to-Sleep	Event will Wake-from-Sleep
SRC_FIFO	Yes	No
SRC_TRANS	Yes	Yes
SRC_LNDPRT	Yes	Yes
SRC_PULSE	Yes	Yes
SRC_FFMT	Yes	Yes
SRC_ASLP	No*	No*
SRC_AVECM	Yes	Yes

\* If the *fifo\_gate* bit is set to logic '1', the assertion of the SRC\_ASLP interrupt does not prevent the system from transitioning to Sleep or from Wake mode; instead it prevents the FIFO buffer from accepting new sample data until the host application flushes the FIFO buffer.

The interrupt sources listed in [Table 45](#) affect the auto-sleep, return to sleep and wake from sleep mechanism only if they have been previously enabled. The functional block event flags that are bypassed while the system is in Auto-Sleep mode are temporary disabled (see [Section 10.1.10, "CTRL\\_REG3 \[Interrupt Control Register\] \(0x2C\) register," on page 35 for more information](#)) and are automatically re-enabled when the device returns from Auto-Sleep mode (that is, wakes up), except for the data ready function.

If any of the interrupt sources listed under the Return-to-Sleep column is asserted before the sleep counter reaches the value specified in ASLP\_COUNT, then all sleep mode transitions are terminated and the internal sleep counter is reset. If none of the interrupts listed under the Return-to-Sleep column are asserted within the time limit specified by the ASLP\_COUNT register, the system will transition to the Sleep mode and use the ODR value specified in CTRL\_REG1[*aslp\_rate*].

If any of the interrupt sources listed under the “Wake-from-Sleep” column is asserted, then the system will transition out of the low sample rate Auto-Sleep mode to the user-specified fast sample rate provided the user-specified wake event function is enabled in register CTRL\_REG3.

If the Auto-Sleep interrupt is enabled, a transition from Active mode to Sleep mode and vice-versa will generate an interrupt.

If CTRL\_REG3[*fifo\_gate*] = 1, transitioning to Auto-Sleep mode will preserve the FIFO contents, set SYSMOD[*fgerr*] (FIFO Gate error), and stop new acquisitions. The system will wait for the FIFO buffer to be emptied by the host application before new samples can be acquired.

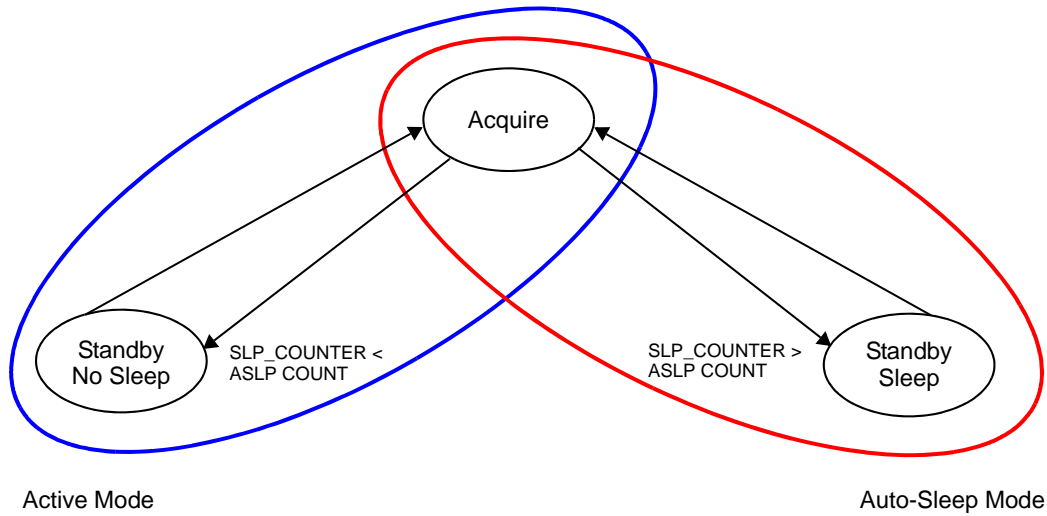

Figure 12. Auto-Sleep state transition diagram



## 10.3 Output data registers

### 10.3.1 OUT\_X\_MSB (0x01), OUT\_X\_LSB (0x02), OUT\_Y\_MSB (0x03), OUT\_Y\_LSB (0x04), OUT\_Z\_MSB (0x05), OUT\_Z\_LSB (0x06) registers

These registers contain the X-axis, Y-axis, and Z-axis 14-bit left-justified sample data expressed as 2's complement numbers.

The sample data output registers store the current sample data if the FIFO buffer function is disabled, but if the FIFO buffer function is enabled the sample data output registers then point to the head of the FIFO buffer which contains up to the previous 32 X, Y, and Z data samples.

The data is read out in the following order: Xmsb, Xlsb, Ymsb, Ylsb, Zmsb, Zlsb for CTRL\_REG1[f\_read] = 0, and Xmsb, Ymsb, Zmsb for CTRL\_REG1[f\_read] = 1. Similarly, for CTRL\_REG1[f\_read] = 1, only the MSB's of the acceleration data are read out in the same axis order.

If the CTRL\_REG1[f\_read] bit is set, auto-increment will skip over the LSB registers. This will shorten the data acquisition from 6 bytes to 3 bytes. If the LSB registers are directly addressed, the LSB information can still be read regardless of the CTRL\_REG1[f\_read] register setting.

If the FIFO data output register driver is enabled (F\_SETUP[f\_mode] > 00), register 0x01 points to the head of the FIFO buffer, while registers 0x02, 0x03, 0x04, 0x05, 0x06 return a value of zero when read directly.

The DR\_STATUS registers, OUT\_X\_MSB, OUT\_X\_LSB, OUT\_Y\_MSB, OUT\_Y\_LSB, OUT\_Z\_MSB, and OUT\_Z\_LSB are located in the auto-incrementing address range of 0x00 to 0x06, allowing all of the acceleration data to be read in a single-burst read of 6 bytes starting at the OUT\_X\_MSB register.

**Table 46. OUT\_X\_MSB register**

xd[13:6]
----------

**Table 47. OUT\_X\_LSB register**

xd[5:0]	—	—
---------	---	---

**Table 48. OUT\_Y\_MSB register**

yd[13:6]
----------

**Table 49. OUT\_Y\_LSB register**

yd[5:0]	—	—
---------	---	---

**Table 50. OUT\_Z\_MSB register**

zd[13:6]
----------

**Table 51. OUT\_Z\_LSB register**

zd[5:0]	—	—
---------	---	---

## 10.4 FIFO

### 10.4.1 F\_SETUP (0x09) register

**Table 52. F\_SETUP register**

f_mode[1:0]	f_wmrk[5:0]
0	6b'000000

**Table 53. F\_SETUP bit descriptions**

Field	Description
f_mode[1:0] <sup>(1)(2)(3)</sup>	<p>FIFO buffer operating mode.</p> <p><b>00:</b> FIFO is disabled.</p> <p><b>01:</b> FIFO contains the most recent samples when overflowed (circular buffer). Oldest sample is discarded to be replaced by new sample.</p> <p><b>10:</b> FIFO stops accepting new samples when overflowed.</p> <p><b>11:</b> FIFO trigger mode.</p> <p>The FIFO is flushed whenever the FIFO is disabled, during an automatic ODR change (Auto-Wake/Sleep), or on a transition from Standby mode to Active mode.</p> <p>Disabling the FIFO (<i>f_mode</i> = 2'b00) resets the F_STATUS[<i>f_ovf</i>], F_STATUS[<i>f_wmrk_flag</i>], F_STATUS[<i>f_cnt</i>] status flags to zero.</p> <p>A FIFO overflow event (that is, F_STATUS[<i>f_cnt</i>] = 32) will assert the F_STATUS[<i>f_ovf</i>] flag.</p>
f_wmrk[5:0] <sup>(2)</sup>	<p>FIFO sample count watermark.</p> <p>These bits set the number of FIFO samples required to trigger a watermark interrupt. A FIFO watermark event flag F_STATUS[<i>f_wmk_flag</i>] is raised when FIFO sample count F_STATUS[<i>f_cnt</i>] value is equal to or greater than the <i>f_wmrk</i> watermark.</p> <p>Setting the <i>f_wmrk</i> to 6'b000000 will disable the FIFO watermark event flag generation.</p> <p>This field is also used to set the number of pre-trigger samples in trigger mode (<i>f_mode</i> = 2'b11).</p>

1. This bit field can be written in Active mode.
2. This bit field can be written in Standby mode.
3. The FIFO mode (*f\_mode*) cannot be switched between operational modes (01, 10 and 11).

A FIFO sample count exceeding the watermark event does not stop the FIFO from accepting new data.

The FIFO update rate is dictated by the selected system ODR. In Active mode the ODR is set by CTRL\_REG1[*dr*] and when Auto-Sleep is active, the ODR is set by CTRL\_REG1[*aslp\_rate*] bit fields.

When data is read from the FIFO buffer, the oldest sample data in the buffer is returned and also deleted from the front of the FIFO, while the FIFO sample count is decremented by one. It is assumed that the host application will use the I<sup>2</sup>C or SPI burst read transactions to dump the FIFO contents. If the FIFO X, Y, and Z data is not completely read in one burst read transaction, the next read will start at the next FIFO location X-axis data. If the Y or Z data is not read out in the same burst transaction as the X-axis data, it will be lost.

In Trigger mode, the FIFO is operated as a circular buffer and will contain up to the 32 most recent acceleration data samples. The oldest sample is discarded and replaced by the current sample, until a FIFO trigger event occurs. After a trigger event occurs, the FIFO will continue to accept samples only until overflowed, after which point the newest sample data is discarded. For more information on using the FIFO buffer and the various FIFO operating modes, please refer to Freescale application note AN4073.

## 10.5 Sensor data configuration

### 10.5.1 XYZ\_DATA\_CFG (0x0E) register

The XYZ\_DATA\_CFG register is used to configure the desired acceleration full-scale range, and also to select whether the output data is passed through the high-pass filter.

**Table 54. XYZ\_DATA\_CFG register**

—	—	—	hpf_out	—	—	fs[1:0]
0	0	0	0	0	0	0

**Table 55. XYZ\_DATA\_CFG bit descriptions**

Field	Description
hpf_out	Enable high-pass filter on acceleration output data 1: Output data is high-pass filtered 0: High-pass filter is disabled.
fs[1:0]	Accelerometer full-scale range selection. See <a href="#">Table 56</a>

**Table 56.**

fs[1]	fs[0]	Full-Scale range
0	0	±0.244 mg/LSB
0	1	±0.488 mg/LSB
1	0	±0.976 mg/LSB
1	1	Reserved

## 10.6 High-Pass filter

### 10.6.1 HP\_FILTER\_CUTOFF (0x0F) register

High-pass filter cutoff frequency setting register.

**Table 57. HP\_FILTER\_CUTOFF register**

—	—	pulse_hpf_byp	pulse_lpf_en	—	—	sel[1:0]
0	0	0	0	0	0	0

**Table 58. HP\_FILTER\_CUTOFF bit descriptions**

Field	Description
pulse_hpf_byp	Bypass high-pass filter for pulse processing function 0: HPF enabled for pulse processing 1: HPF bypassed for pulse processing
pulse_lpf_en	Enable low-pass filter for pulse processing function 0: LPF disabled for pulse processing 1: LPF enabled for pulse processing
sel[1:0]	HPF cutoff frequency selection See <a href="#">Table 59</a> .

**Table 59. HP\_FILTER\_CUTOFF**

High-Pass cutoff frequency (Hz)								
ODR (Hz)	sel = 2'b00				sel = 2'b01			
	Normal	LPLN	High resolution	Low power	Normal	LPLN	High resolution	Low power
800	16	16	16	16	8	8	8	8
400	16	16	16	8	8	8	8	4
200	8	8	16	4	4	4	8	2
100	4	4	16	2	2	2	8	1
50	2	2	16	1	1	1	8	0.5
12.5	2	0.5	16	0.25	1	0.25	8	0.125
6.25	2	0.25	16	0.125	1	0.125	8	0.063
1.56	2	0.063	16	0.031	1	0.031	8	0.016
ODR (Hz)	sel = 2'b10				sel = 2'b11			
	Normal	LPLN	High resolution	Low power	Normal	LPLN	High resolution	Low power
800	4	4	4	4	2	2	2	2
400	4	4	4	2	2	2	2	1
200	2	2	4	1	1	1	2	0.5
100	1	1	4	0.5	0.5	0.5	2	0.25
50	0.5	0.5	4	0.25	0.25	0.25	2	0.125
12.5	0.5	0.125	4	0.063	0.25	0.063	2	0.031
6.25	0.5	0.063	4	0.031	0.25	0.031	2	0.016
1.56	0.5	0.016	4	0.008	0.25	0.008	2	0.004

## 10.7 Portrait/Landscape Detection

The FXLS8471Q is capable of detecting six orientations: Landscape Left, Landscape Right, Portrait Up, and Portrait Down with Z-lockout feature as well as Face Up and Face Down orientation as shown in Figures 13, 14 and 15. For more details on the meaning of the different user-configurable settings and for example code, please refer to Freescale application note AN4068.

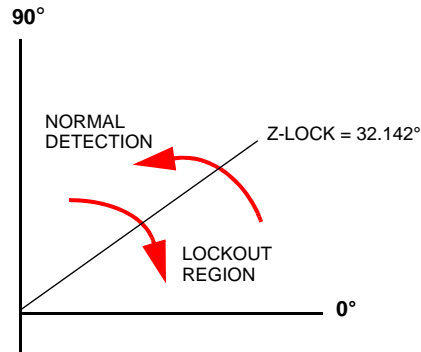

Figure 13. Illustration of Z-tilt angle lockout transition

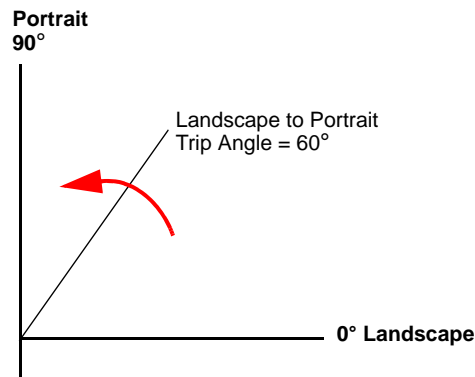

Figure 14. Illustration of landscape to portrait transition

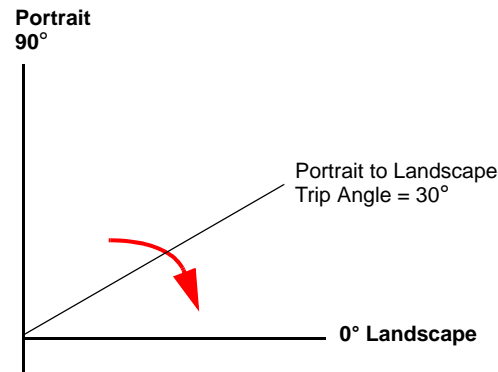

Figure 15. Illustration of portrait to landscape transition

### 10.7.1 PL\_STATUS (0x10) register

This status register can be read to get updated information on any change in orientation by reading bit 7, or the specifics of the orientation by reading the other bits. For further understanding of Portrait Up, Portrait Down, Landscape Left, Landscape Right, Back and Front orientations please refer to [Figure 15](#). The interrupt is cleared when reading the PL\_STATUS register.

**Table 60. PL\_STATUS register**

newlp	lo	—	—	—	lapo[1]	lapo[0]	bafro
0	0	0	0	0	0	0	0

**Table 61. PL\_STATUS bit descriptions**

Field	Description
newlp	Landscape/Portrait status change flag. 0: No change 1: BAFRO and/or LAPO and/or Z-tilt lockout value has changed
lo	Z-tilt angle lockout. 0: Lockout condition has not been detected. 1: Z-tilt lockout trip angle has been exceeded. Lockout condition has been detected.
lapo[1:0] <sup>(1)</sup>	Landscape/Portrait orientation. 00: Portrait up: equipment standing vertically in the normal orientation 01: Portrait down: equipment standing vertically in the inverted orientation 10: Landscape right: equipment is in landscape mode to the right 11: Landscape left: equipment is in landscape mode to the left.
bafro	Back or front orientation. 0: Front: equipment is in the front facing orientation. 1: Back: equipment is in the back facing orientation.

1. The default powerup state is *bafro*(Undefined), *lapo*(Undefined), and no lockout for orientation function.

The *newlp* bit is set to 1 after the first orientation detection after a Standby to Active transition, and whenever a change in *lo*, *bafro*, or *lapo* occurs. The *newlp* bit is cleared anytime the PL\_STATUS register is read. *lapo*, *bafro* and *lo* continue to change when *newlp* is set. The current orientation is locked if the absolute value of the acceleration experienced on any of the three axes is greater than 1.25 g.

## 10.7.2 PL\_CFG (0x11) register

This register enables the Portrait/Landscape function and sets the behavior of the debounce counter.

**Table 62. PL\_CFG register**

dbcntm	pl_en	—	—	—	—	—	—
1	0	0	0	0	0	0	0

**Table 63. PL\_CFG bit descriptions**

Field	Description
dbcntm	Debounce counter mode selection. 0: Decrements debounce whenever condition of interest is no longer valid. 1: Clears counter whenever condition of interest is no longer valid.
pl_en	Portrait/Landscape detection enable. 0: Portrait/Landscape detection is disabled. 1: Portrait/Landscape detection is enabled.

## 10.7.3 PL\_COUNT (0x12) register

This register sets the debounce count for the orientation state transition. The minimum debounce latency is determined by the system ODR value and the value of the PL\_COUNT register. Any change to the system ODR or a transition from Active to Standby (or vice-versa) resets the internal landscape/portrait internal debounce counters.

**Table 64. PL\_COUNT register**

dbnce[7:0]
8'b00000000

**Table 65. PL\_Count Relationship with the ODR**

ODR (Hz)	Max time range (s)				Time step (ms)			
	Normal	LPLN	High resolution	Low power	Normal	LPLN	High resolution	Low power
800	0.319	0.319	0.319	0.319	1.25	1.25	1.25	1.25
400	0.638	0.638	0.638	0.638	2.5	2.5	2.5	2.5
200	1.28	1.28	0.638	1.28	5	5	2.5	5
100	2.55	2.55	0.638	2.55	10	10	2.5	10
50	5.1	5.1	0.638	5.1	20	20	2.5	20
12.5	5.1	20.4	0.638	20.4	20	80	2.5	80
6.25	5.1	20.4	0.638	40.8	20	80	2.5	160
1.56	5.1	20.4	0.638	40.8	20	80	2.5	160

## 10.7.4 PL\_BF\_ZCOMP (0x13) register

Back/Front and Z-tilt angle compensation register

**Table 66. PL\_BF\_ZCOMP register**

bkfr[1:0]	—	—	—	zlock[2:0]
2'b10	0	0	0	3'b100

**Table 67. PL\_BF\_ZCOMP bit descriptions**

Field	Description
zlock[2:0]	Z-lock angle threshold. range is from approximately 13° to 44°. Step size is approximately 4°. See <a href="#">Table 68</a> for more information. Default value: <b>0x04</b> → ~28°. Maximum value: <b>0x07</b> → ~44°.
bkfr[1:0]	Back/front trip angle threshold. See <a href="#">Table 69</a> for more information. Default: <b>2'b10</b> → ±70°. Step size is 5°. Range: ±(65° to 80°).

**Table 68. Z-lockout angle definitions**

zlock	Resultant angle (min) for positions between Landscape and Portrait	Resultant angle (max) for ideal Landscape or Portrait
0x00	13.6°	14.5°
0x01	17.1°	18.2°
0x02	20.7°	22.0°
0x03	24.4°	25.9°
0x04	28.1°	30.0°
0x05	32.0°	34.2°
0x06	36.1°	38.7°
0x07	40.4°	43.4°

**Table 69. Back/Front orientation definitions**

bkfr	Back → Front Transition	Front → Back Transition
00	Z < 80° or Z > 280°	Z > 100° and Z < 260°
01	Z < 75° or Z > 285°	Z > 105° and Z < 255°
10	Z < 70° or Z > 290°	Z > 110° and Z < 250°
11	Z < 65° or Z > 295°	Z > 115° and Z < 245°



## 10.7.5 PL\_THS\_REG (0x14) register

Portrait to landscape trip threshold registers.

**Table 70. PL\_THS\_REG register**

pl_ths[4:0]	hys[2:0]
5'b01000	3'b100

**Table 71. Threshold angle lookup table**

pl_ths[4:0] value	Threshold angle (approx.)
0x07	15°
0x09	20°
0x0C	30°
0x0D	35°
0x0F	40°
0x10	45°
0x13	55°
0x14	60°
0x17	70°
0x19	75°

**Table 72. Trip angles versus hysteresis settings**

hys[2:0] value	Landscape to Portrait trip angle	Portrait to Landscape trip angle
0	45°	45°
1	49°	41°
2	52°	38°
3	56°	34°
4	59°	31°
5	62°	28°
6	66°	24°
7	69°	21°

**Table 73. Portrait/Landscape ideal orientation definitions**

Position	Description
PU	y ~ -1 g, x ~ 0
PD	y ~ +1 g, x ~ 0
LR	y ~ 0, x ~ +1 g
LL	y ~ 0, x ~ -1 g

## 10.8 Frefall and Motion detection

The Frefall/Motion detection block can be configured to detect low-g (freefall) or high-g (motion) events utilizing the A\_FFMT\_CFG[a\_ffmt\_oe] bit.

In low-g detect mode (A\_FFMT\_CFG[a\_ffmt\_oe] = 0) a low-g condition will need to occur on all enabled axes (ex. X, Y and Z) for the A\_FFMT\_SRC[a\_ffmt\_ea] bit to be affected. And, in high-g detect mode (A\_FFMT\_CFG[a\_ffmt\_oe] = 1) a high-g condition occurring in any of the enabled axes (ex. X, Y or Z) will suffice to affect the A\_FFMT\_SRC[a\_ffmt\_ea] bit.

The detection threshold(s) are programed in register 0x17 (A\_FFMT\_THS) for common threshold operation, and 0x73-0x78 (A\_FFMT\_THS\_X/Y/Z) for individual axis threshold operation.

A\_FFMT\_CFG[a\_ffmt\_ele] bit determines the behavior of A\_FFMT\_SRC[a\_ffmt\_ea] bit in response to the desired acceleration event (low-g/high-g). When A\_FFMT\_CFG[a\_ffmt\_ele] = 1, the freefall or motion event is latched and the

A\_FFMT\_SRC[a\_ffmt\_ea] flag can only be cleared by reading the A\_FFMT\_SRC register. When A\_FFMT\_CFG[a\_ffmt\_ele] = 0, freefall or motion events are not latched, and the A\_FFMT\_SRC[a\_ffmt\_ea] bit reflects the real-time status of the event detection.

A\_FFMT\_THS[a\_ffmt\_dbcntm] bit determines the debounce filtering behavior of the logic which sets the A\_FFMT\_SRC[a\_ffmt\_ea] bit. See Figure 17 for details.

It is possible to enable/disable each axis used in the freefall/motion detection function by configuring bits A\_FFMT\_CFG[a\_ffmt\_xefe], A\_FFMT\_CFG[a\_ffmt\_yefe], and A\_FFMT\_CFG[a\_ffmt\_zefe].

The freefall/motion detection function has the option to use a common 7-bit unsigned threshold for each of the X, Y, Z axes, or individual unsigned 13-bit thresholds for each axis. When A\_FFMT\_THS\_X\_MSB[a\_ffmt\_ths\_xyz\_en] = 0, the 7-bit threshold value stored in register 0x17 is used as a common 7-bit threshold for the X, Y, and Z axes. When a\_ffmt\_ths\_xyz\_en = 1, each axis may be programmed with an individual 13-bit threshold (stored in the A\_FFMT\_X/Y/Z MSB and LSB registers).

### 10.8.1 A\_FFMT\_CFG (0x15) register

Freefall/motion configuration register.

**Table 74. A\_FFMT\_CFG register**

a_ffmt_ele	a_ffmt_oae	a_ffmt_zefe	a_ffmt_yefe	a_ffmt_xefe	—	—	—
0	0	0	0	0	0	0	0

**Table 75. A\_FFMT\_CFG bit descriptions**

Field	Description
a_ffmt_ele	a_ffmt_ele denotes whether the enabled event flag will be latched in the A_FFMT_SRC register or the event flag status in the A_FFMT_SRC will indicate the real-time status of the event. If a_ffmt_ele bit is set to a logic '1', then the event flags are frozen when the a_ffmt_ea bit gets set, and are cleared by reading the A_FFMT_SRC source register. Default value: 0 0: Event flag latch disabled 1: Event flag latch enabled
a_ffmt_oae	a_ffmt_oae bit allows the selection between motion (logical OR combination of high-g X, Y, Z-axis event flags) and freefall (logical AND combination of low-g X, Y, Z-axis event flags) detection. Motion detect/freefall detect logic selection. Default value: 0 (freefall flag) 0: Freefall flag (Logical AND combination of low-g X, Y, Z-axis event flags) 1: Motion flag (Logical OR combination of high-g X, Y, Z event flags)
a_ffmt_zefe	a_ffmt_zefe enables the detection of a high- or low-g event when the measured acceleration data on Z-axis is above/below the threshold set in the A_FFMT_THS register. If the a_ffmt_ele bit is set to logic '1' in the A_FFMT_CFG register, new event flags are blocked from updating the A_FFMT_SRC register. Default value: 0 0: Event detection disabled 1: Raise event flag on measured Z-axis acceleration above/below threshold.
a_ffmt_yefe	a_ffmt_yefe enables the detection of a high- or low-g event when the measured acceleration data on Y-axis is above/below the threshold set in the A_FFMT_THS register. If the a_ffmt_ele bit is set to logic '1' in the A_FFMT_CFG register, new event flags are blocked from updating the A_FFMT_SRC register. Default value: 0 0: Event detection disabled 1: Raise event flag on measured Y-axis acceleration above/below threshold.
a_ffmt_xefe	a_ffmt_xefe enables the detection of a high- or low-g event when the measured acceleration data on X-axis is above/below the threshold set in the A_FFMT_THS register. If the a_ffmt_ele bit is set to logic '1' in the A_FFMT_CFG register, new event flags are blocked from updating the A_FFMT_SRC register. Default value: 0 0: Event detection disabled 1: Raise event flag on measured X-axis acceleration above/below threshold.

## 10.8.2 A\_FFMT\_SRC (0x16) register

Freefall/motion source register. Read-only register.

This register keeps track of the acceleration event which is triggering (or has triggered, in case of A\_FFMT\_CFG[a\_ffmt\_ele] = 1) the event flag. In particular A\_FFMT\_SRC[a\_ffmt\_ea] is set to a logic '1' when the logical combination of acceleration event flags specified in A\_FFMT\_CFG register is true. This bit is used in combination with the values in CTRL\_REG4[int\_en\_ffmt] and CTRL\_REG5[int\_cfg\_ffmt] register bits to generate the freefall/motion interrupts.

**Table 76. A\_FFMT\_SRC register**

a_ffmt_ea	—	a_ffmt_zhe	a_ffmt_zhp	a_ffmt_yhe	a_ffmt_yhp	a_ffmt_xhe	a_ffmt_xhp
0	0	0	0	0	0	0	0

**Table 77. A\_FFMT\_SRC bit descriptions**

Field	Description
a_ffmt_ea	Event active flag. Default value: 0 0: No event flag has been asserted 1: One or more event flag has been asserted. See the description of the A_FFMT_CFG[a_ffmt_oe] bit to determine the effect of the 3-axis event flags on the a_ffmt_ea bit.
a_ffmt_zhe	Z-high event flag. Default value: 0 0: Event detected 1: Z-high event has been detected This bit always reads zero if the a_ffmt_zefe control bit is set to zero
a_ffmt_zhp	Z-high event polarity flag. Default value: 0 0: Z event was positive <i>g</i> 1: Z event was negative <i>g</i> This bit read always zero if the a_ffmt_zefe control bit is set to zero
a_ffmt_yhe	Y-high event flag. Default value: 0 0: No event detected 1: Y-high event has been detected This bit read always zero if the a_ffmt_yefe control bit is set to zero
a_ffmt_yhp	Y-high event polarity flag. Default value: 0 0: Y event detected was positive <i>g</i> 1: Y event was negative <i>g</i> This bit always reads zero if the a_ffmt_yefe control bit is set to zero
a_ffmt_xhe	X-high event flag. Default value: 0 0: No event detected 1: X-high event has been detected This bit always reads zero if the a_ffmt_xefe control bit is set to zero
a_ffmt_xhp	X-high event polarity flag. Default value: 0 0: X event was positive <i>g</i> 1: X event was negative <i>g</i> This bit always reads zero if the a_ffmt_xefe control bit is set to zero

### 10.8.3 A\_FFMT\_THS (0x17), A\_FFMT\_THS\_X\_MSB (0x73), A\_FFMT\_THS\_X\_LSB (0x74), A\_FFMT\_THS\_Y\_MSB (0x75), A\_FFMT\_THS\_Y\_LSB (0x76), A\_FFMT\_THS\_Z\_MSB (0x77), A\_FFMT\_THS\_Z\_LSB (0x78) registers

Freefall/motion detection threshold registers.

**Table 78. A\_FFMT\_THS (0x17) register**

a_ffmt_dbcntm	ths[6:0]
0	7'b0000000

**Table 79. A\_FFMT\_THS (0x17) bit descriptions**

Field	Description
a_ffmt_dbcntm	The ASIC uses <i>a_ffmt_dbcntm</i> to set the acceleration FFMT debounce counter clear mode independent of the value of the <i>a_ffmt_ths_xyz_en</i> . <i>a_ffmt_dbcntm</i> bit configures the way in which the debounce counter is reset when the inertial event of interest is momentarily not true. When <i>a_ffmt_dbcntm</i> bit is a logic '1', the debounce counter is cleared to 0 whenever the inertial event of interest is no longer true (part b, <a href="#">Figure 17</a> ) while if the <i>a_ffmt_dbcntm</i> bit is set to logic '0' the debounce counter is decremented by 1 whenever the inertial event of interest is longer true (part c, <a href="#">Figure 17</a> ) until the debounce counter reaches 0 or the inertial event of interest become active. The decrementing of the debounce counter acts to filter out irregular spurious events which might impede the correct detection of inertial events.
ths[6:0]	Freefall/motion detection threshold: default value: 7'b0000000. Resolution is fixed at 63 mg/LSB.

**Table 80. A\_FFMT\_THS\_X\_MSB (0x73) register**

a_ffmt_ths_xyz_en	a_ffmt_ths_x[12:6]
0	7'b0000000

**Table 81. A\_FFMT\_THS\_X\_MSB (0x73) bit descriptions**

Field	Description
a_ffmt_ths_xyz_en	For <i>a_ffmt_ths_xyz_en</i> = 0 the ASIC uses the <i>ffmt_ths</i> [6:0] value located in register x17[6:0] as a common threshold for the X, Y, and Z-axis acceleration detection. The common unsigned 7-bit acceleration threshold has a fixed resolution of 63 mg/LSB, with a range of 0-127 counts. For <i>a_ffmt_ths_xyz_en</i> = 1 the ASIC ignores the common 7-bit G_FFMT_THS value located in register x17 when executing the FFMT function, and the following independent threshold values are used for each axis: A_FFMT_THS_X_MSB and A_FFMT_THS_X_LSB are used for the X-axis acceleration threshold, A_FFMT_THS_Y_MSB and A_FFMT_THS_Y_LSB for the Y-axis acceleration threshold, A_FFMT_THS_Z_MSB and A_FFMT_THS_Z_LSB for the Z-axis acceleration threshold. The A_FFMT_THS_X/Y/Z thresholds are 13-bit unsigned values that have the same resolution as the accelerometer output data determined by XYZ_DATA_CFG fs [1:0]. The <i>a_ffmt_ths_xyz_en</i> and <i>a_ffmt_trans_ths_en</i> bits must not be enabled simultaneously.
a_ffmt_ths_x[12:6]	7-bit MSB of X-axis acceleration threshold

**Table 82. A\_FFMT\_THS\_X\_LSB (0x74) register**

a_ffmt_ths_x[5:0]	—	—
6'b000000	0	0

**Table 83. A\_FFMT\_THS\_Y\_MSB (0x75) register**

a_ffmt_trans_ths_en	a_ffmt_ths_y[12:6]
0	7'b0000000

**Table 84. A\_FFMT\_THS\_Y\_LSB (0x76) register**

a_ffmt_ths_y[5:0]	—	—
6'b000000	0	0

**Table 85. A\_FFMT\_THS\_Z\_MSB (0x77) register**

—	a_ffmt_ths_z[12:6]
0	7'b0000000

**Table 86. A\_FFMT\_THS\_Z\_LSB (0x78) register**

a_ffmt_ths_z[5:0]	—	—
6'b0000000	0	0

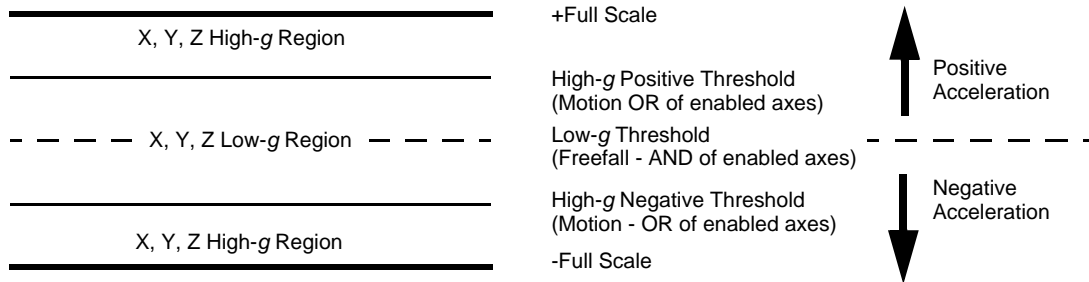

**Figure 16. A\_FFMT\_THS high and low-g level**

A\_FFMT\_THS contains the unsigned 7-bit threshold value used by the freefall/motion detection functional block and is used to detect either low-g (freefall) or high-g (motion) events depending on the setting of G\_FFMT\_CFG[*f\_ffmt\_oae*]. If *g\_ffmt\_oae* = 0, the event is detected when the absolute value of all the enabled axes are below the threshold value. When *g\_ffmt\_oae* = 1, the event is detected when the absolute value of any of the enabled axes is above the threshold value (see Figure 16 for an illustration of the freefall/motion event detection thresholds). If A\_FFMT\_THS\_X\_MSB[*a\_ffmt\_ths\_xyz\_en*] = 1, the behavior is identical, except that each axis may be programmed with an individual 13-bit threshold (stored in the A\_FFMT\_X/Y/Z MSB and LSB registers).

#### 10.8.4 A\_FFMT\_COUNT (0x18) register

Debounce count register for freefall/motion detection events

This register sets the number of debounce counts for acceleration sample data matching the user-programmed conditions for either a freefall or motion detection event required before the interrupt is triggered.

**Table 87. A\_FFMT\_COUNT register**

a_ffmt_count[7:0]
8'b00000000

**Table 88. A\_FFMT\_COUNT bit description**

Field	Description
a_ffmt_count[7:0]	<i>a_ffmt_count</i> defines the minimum number of debounce sample counts required for the detection of a freefall or motion event. A_FFMT_THS[ <i>ffmt_dbcntm</i> ] determines the behavior of the counter when the condition of interest is momentarily not true.

When the internal debounce counter reaches the A\_FFMT\_COUNT value a freefall/motion event flag is set. The debounce counter will never increase beyond the A\_FFMT\_COUNT value. The time step used for the debounce sample count depends on the ODR chosen (see Table 89).

**Table 89. A\_FFMT\_COUNT relationship with the ODR**

ODR (Hz)	Max time range (s)				Time step (ms)			
	Normal	LPLN	High resolution	Low power	Normal	LPLN	High resolution	LP
800	0.319	0.319	0.319	0.319	1.25	1.25	1.25	1.25
400	0.638	0.638	0.638	0.638	2.5	2.5	2.5	2.5
200	1.28	1.28	0.638	1.28	5	5	2.5	5
100	2.55	2.55	0.638	2.55	10	10	2.5	10
50	5.1	5.1	0.638	5.1	20	20	2.5	20
12.5	5.1	20.4	0.638	20.4	20	80	2.5	80
6.25	5.1	20.4	0.638	40.8	20	80	2.5	160
1.56	5.1	20.4	0.638	40.8	20	80	2.5	160

For example, an ODR of 100 Hz and a A\_FFMT\_COUNT value of 15 would result in minimum debounce response time of 150 ms.

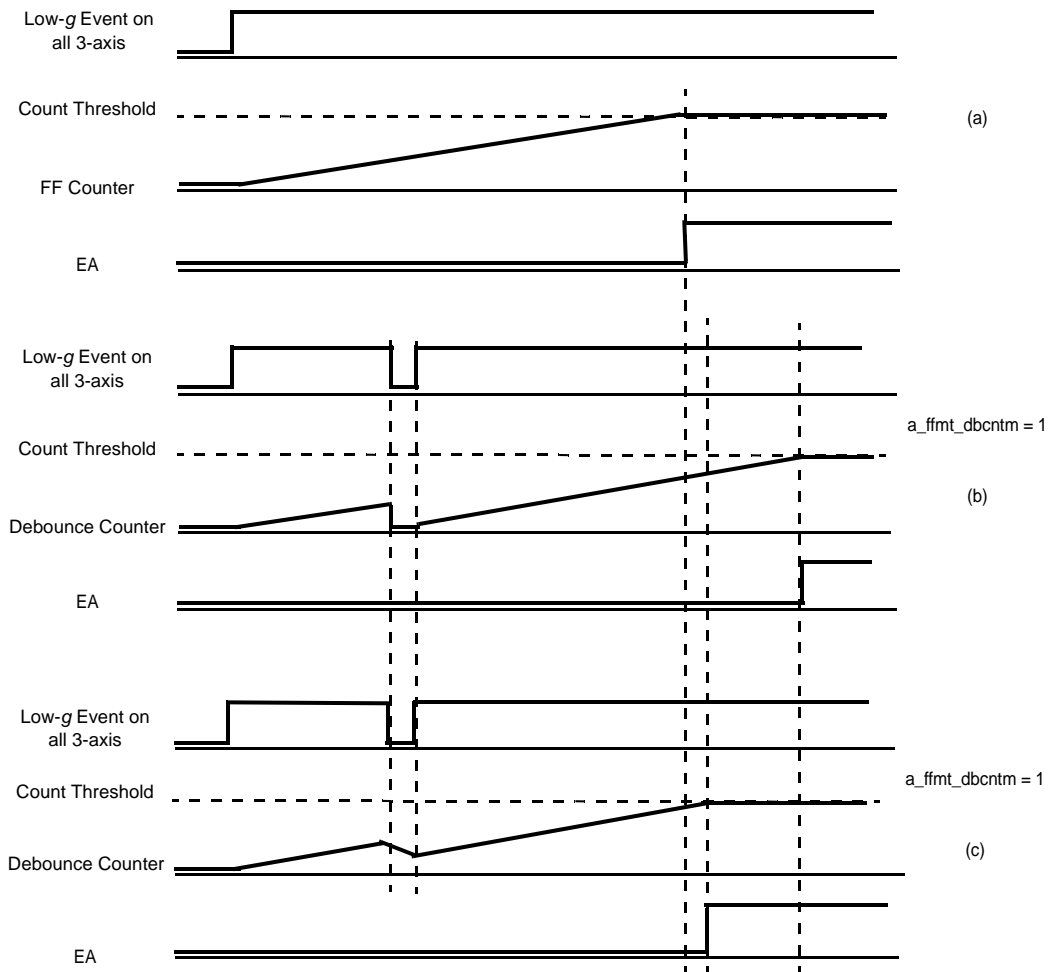

**Figure 17. Behavior of the A\_FFMT debounce counter in relation to the a\_ffmt\_dbcntm setting**

## 10.9 Accelerometer vector-magnitude function

The accelerometer vector-magnitude function is an inertial event detection function available to assist host software algorithms in detecting motion events.

If  $\sqrt{(a_{x\_out} - a_{x\_ref})^2 + (a_{y\_out} - a_{y\_ref})^2 + (a_{z\_out} - a_{z\_ref})^2} > A\_VECM\_THS$  for a time period greater than the value stored in `A_VECM_CNT`, the vector-magnitude change event flag is triggered.

`a_x_out`, `a_y_out`, and `a_z_out` are the current accelerometer output values, and `a_x_ref`, `a_y_ref`, and `a_z_ref` are the reference values stored internally in the ASIC for each axis or in `A_VECM_INIT_X/Y/Z` registers if `A_VECM_CFG[a_vecm_initm]` is set.

Please note that the `x_ref`, `y_ref`, and `z_ref` values are not directly visible to the host application through the register interface. Please refer to Freescale application note 4458.

### 10.9.1 A\_VECM\_CFG (0x5F) register

Table 90. A\_VECM\_CFG register

—	<code>a_vecm_ele</code>	<code>a_vecm_initm</code>	<code>a_vecm_updm</code>	<code>a_vecm_en</code>	—	—	—
0	0	0	0	0	0	0	0

Table 91. A\_VECM\_CFG bit descriptions

Field	Description
<code>a_vecm_ele</code>	Control bit <code>a_vecm_ele</code> defines the event latch enable mode. Event latching is disabled for <code>a_vecm_ele = 0</code> . In this case, the vector-magnitude interrupt flag is in updated real-time and is cleared when the condition for triggering the interrupt is no longer true. The setting and clearing of the event flag is controlled by the <code>A_VECM_CNT</code> register's programmed debounce time. For <code>a_vecm_ele = 1</code> , the interrupt flag is latched in and held until the host application reads the <code>INT_SOURCE</code> register (0x0C).
<code>a_vecm_initm</code>	Control bit <code>a_vecm_initm</code> defines how the initial reference values ( <code>x_ref</code> , <code>y_ref</code> , and <code>z_ref</code> ) are chosen. For <code>a_vecm_initm = 0</code> the function uses the current x/y/z accelerometer output data at the time when the vector magnitude function is enabled. For <code>a_vecm_initm = 1</code> the function uses the data from <code>A_VECM_INIT_X/Y/Z</code> registers as the initial reference values.
<code>a_vecm_updm</code>	Control bit <code>a_vecm_updm</code> defines how the reference values are updated once the vector-magnitude function has been triggered. For <code>a_vecm_updm = 0</code> , the function updates the reference value with the current x, y, and z accelerometer output data values. For <code>a_vecm_updm = 1</code> , the function does not update the reference values when the interrupt is triggered. Instead the function continues to use the reference values that were loaded when the function was enabled. If both <code>a_vecm_initm</code> and <code>a_vecm_updm</code> are set to logic '1', the host software can manually update the reference values in real time by writing to the <code>A_VECM_INITX,Y,Z</code> registers.
<code>a_vecm_en</code>	The accelerometer vector-magnitude function is enabled by setting <code>a_vecm_en = 1</code> , and disabled by clearing this bit (default). The reference values are loaded with either the current X/Y/Z acceleration values or the values stored in the <code>A_VECM_INIT_X/Y/Z</code> registers, depending on the state of the <code>a_vecm_initm</code> bit. <b>Note:</b> The vector-magnitude function will only perform correctly up to a maximum ODR of 400 Hz.

## 10.9.2 A\_VECM\_THS\_MSB (0x60) register

Table 92. A\_VECM\_THS\_MSB register

a_vecm_dbcntm	—	—	a_vecm_ths[12:8]
0	0	0	5'b00000

Table 93. A\_VECM\_THS\_MSB bit descriptions

Field	Description
a_vecm_dbcntm	Control bit <i>a_vecm_dbcntm</i> defines how the debounce timer is reset when the condition for triggering the interrupt is no longer true. When <i>a_vecm_dbcntm</i> = 0 the debounce counter is decremented by 1 when the vector-magnitude result is below the programmed threshold value. When <i>a_vecm_dbcntm</i> = 1 the debounce counter is cleared when the vector-magnitude result is below the programmed threshold value.
a_vecm_ths[12:8]	Five MSBs of the 13-bit unsigned A_VECM_THS value. The resolution is equal to the selected accelerometer resolution set in XYZ_DATA_CFG[fs]

## 10.9.3 A\_VECM\_THS\_LSB (0x61) register

Table 94. A\_VECM\_THS\_LSB register

a_vecm_ths[7:0]
8'b00000000

## 10.9.4 A\_VECM\_CNT (0x62) register

Table 95. A\_VECM\_CNT register

a_vecm_cnt[7:0]
8'b00000000

Table 96. A\_VECM\_CNT bit description

Field	Description
a_vecm_cnt[7:0]	Vector-magnitude function debounce count value.

The debounce timer period is determined by the ODR selected in CTRL\_REG1; it is equal to the number indicated in A\_VECM\_CNT register times 1/ODR. For example, a value of 16 in A\_VECM\_CNT with an ODR setting of 400 Hz will result in a debounce period of 40 ms.



## 10.9.5 A\_VECM\_INITX\_MSB (0x63) register

Table 97. A\_VECM\_INITX\_MSB register

—	—	a_vecm_initx[13:8]
0	0	6'b000000

Table 98. A\_VECM\_INITX\_MSB bit description

Field	Description
a_vecm_initx[13:8]	Most significant 6 bits of the signed 14-bit initial X-axis value to be used as ref_x when A_VECM_CFG[a_vecm_initm] = 1. The resolution is determined by the settings made in XYZ_DATA_CFG[fs], and is equal to the accelerometer resolution.

## 10.9.6 A\_VECM\_INITX\_LSB (0x64) register

Table 99. A\_VECM\_INITX\_LSB register

a_vecm_initx[7:0]
8'b00000000

Table 100. A\_VECM\_INITX\_LSB bit description

Field	Description
a_vecm_initx[7:0]	LSB of the signed 14-bit initial X-axis value to be used as ref_x when A_VECM_CFG[a_vecm_initm] = 1. The resolution is determined by the settings made in XYZ_DATA_CFG[fs], and is equal to the accelerometer resolution.

## 10.9.7 A\_VECM\_INITY\_MSB (0x65) register

Table 101. A\_VECM\_INITY\_MSB register

—	—	a_vecm_inity[13:8]
0	0	6'b000000

Table 102. A\_VECM\_INITY\_MSB bit description

Field	Description
a_vecm_inity[13:8]	Most significant 6 bits of the signed 14-bit initial Y-axis value to be used as ref_y when A_VECM_CFG[a_vecm_initm] = 1. The resolution is determined by the settings made in XYZ_DATA_CFG[fs], and is equal to the accelerometer resolution.

## 10.9.8 A\_VECM\_INITY\_LSB (0x66) register

Table 103. A\_VECM\_INITY\_LSB register

a_vecm_inity[7:0]
-------------------

Table 104. A\_VECM\_INITY\_LSB bit description

Field	Description
a_vecm_inity[7:0]	LSB of the signed 14-bit initial Y-axis value to be used as ref_y when A_VECM_CFG[a_vecm_initm] = 1. The resolution is determined by the settings made in XYZ_DATA_CFG[fs], and is equal to the accelerometer resolution.

## 10.9.9 A\_VECM\_INITZ\_MSB (0x67) register

Table 105. A\_VECM\_INITZ\_MSB register

—	—	a_vecm_initz[13:8]
0	0	6'b000000

**Table 106. A\_VECM\_INITZ\_MSB bit description**

Field	Description
a_vecm_initz[13:8]	Most significant 6 bits of the signed 14-bit initial Z-axis value to be used as ref_z when A_VECM_CFG[a_vecm_initm] = 1. The resolution is determined by the settings made in XYZ_DATA_CFG[fs], and is equal to the accelerometer resolution.

### 10.9.10 A\_VECM\_INITZ\_LSB (0x68) register

**Table 107. A\_VECM\_INITZ\_LSB register**

a_vecm_initz[7:0]
8'b00000000

**Table 108. A\_VECM\_INITZ\_LSB bit description**

Field	Description
a_vecm_initz[7:0]	LSB of the signed 14-bit initial Z-axis value to be used as ref_z when A_VECM_CFG[a_vecm_initm] = 1. The resolution is determined by the settings made in XYZ_DATA_CFG[fs], and is equal to the accelerometer resolution.

## 10.10 Transient (AC) acceleration detection

The transient detection function is similar to the freefall/motion detection function with the exception that a high-pass filter can be used to eliminate the DC offset from the acceleration data. There is an option to disable the high-pass filter, which causes the transient detection function to work in a similar manner to the motion detection function.

The transient detection function can be configured to signal an interrupt when the high-pass filtered acceleration delta values for any of the enabled axes exceeds the threshold programmed in TRANSIENT\_THS for the debounce time programmed in TRANSIENT\_COUNT. For more information on how to use and configure the transient detection function please refer to Freescale application note AN4461.

### 10.10.1 TRANSIENT\_CFG (0x1D) register

**Table 109. TRANSIENT\_CFG register**

—	—	—	tran_ele	tran_zefe	tran_yefe	tran_xefe	tran_hpf_byp
0	0	0	0	0	0	0	0

**Table 110. TRANSIENT\_CFG bit descriptions**

Field	Description
tran_ele	Transient event flag latch enable. Default value: 0 0: Event flag latch disabled: the transient interrupt flag reflects the real-time status of the function. 1: Event flag latch enabled: the transient interrupt event flag is latched and a read of the TRANSIENT_SRC register is required to clear the event flag.
tran_zefe	Z-axis transient event flag enable. Default value: 0 0: Z-axis event detection disabled 1: Z-axis event detection enabled. Raise event flag on Z-axis acceleration value greater than threshold.
tran_yefe	Y-axis transient event flag enable. Default value: 0 0: Y-axis event detection disabled 1: Y-axis event detection enabled. Raise event flag on Y-axis acceleration value greater than threshold.
tran_xefe	X-axis transient event flag enable. Default value: 0 0: X-axis event detection disabled 1: X-axis event detection enabled. Raise event flag on X-axis acceleration value greater than threshold.
tran_hpf_byp	Transient function high-pass filter bypass. Default value: 0 0: High-pass filter is applied to accelerometer data input to the transient function. 1: High-pass filter is not applied to accelerometer data input to the transient function.

## 10.10.2 TRANSIENT\_SRC (0x1E) register

Transient event flag source register. This register provides the event status of the enabled axes and polarity (directional) information.

**Table 111. TRANSIENT\_CFG register**

—	tran_ea	tran_zef	tran_zpol	tran_yef	tran_ypol	tran_xef	trans_xpol
0	0	0	0	0	0	0	0

**Table 112. TRANSIENT\_SRC bit descriptions**

Field	Description
tran_ea	Transient event active flag. Default value: 0 0: No transient event active flag has been asserted. 1: One or more transient event active flags has been asserted.
tran_zef	Z-axis transient event active flag. Default value: 0 0: Z-axis event flag is not active. 1: Z-axis event flag is active; Z-axis acceleration has exceeded the programmed threshold for the debounce time specified in TRANS_COUNT.
tran_zpol	Z-axis event flag polarity. 0: Z-axis event was above positive threshold value. 1: Z-axis event was below negative threshold value.
tran_yef	Y-axis transient event active flag. Default value: 0 0: Y-axis event flag is not active. 1: Y-axis event flag is active; Y-axis acceleration has exceeded the programmed threshold for the debounce time specified in TRANS_COUNT.
tran_ypol	Y-axis event flag polarity. 0: Y-axis event was above positive threshold value. 1: Y-axis event was below negative threshold value.
tran_xef	X-axis transient event active flag. Default value: 0 0: X-axis event flag is not active. 1: X-axis event flag is active; X-axis acceleration has exceeded the programmed threshold for the debounce time specified in TRANS_COUNT.
tran_xpol	X-axis event flag polarity. 0: X-axis event was above positive threshold value. 1: X-axis event was below negative threshold value.

When TRANSIENT\_CFG[tran\_ele] = 1, the TRANSIENT\_SRC event flag(s) and polarity bits are latched when the interrupt event is triggered, allowing the host application to determine which event flag(s) originally triggered the interrupt. When TRANSIENT\_CFG[tran\_ele] = 0, events which occur after the event that originally triggered the interrupt will update the flag and polarity bits, but once set, the flags can only be cleared by reading the TRANSIENT\_SRC register.

### 10.10.3 TRANSIENT\_THS (0x1F) register

The TRANSIENT\_THS register determines the debounce counter behavior and also sets the transient event detection threshold. It is possible to use A\_FFMT\_THS\_X/Y/Z MSB and LSB registers to set transient acceleration thresholds for individual axes using the *a\_ffmt\_trans\_ths\_en* bit in A\_FFMT\_THS\_Y\_MSB register.

**Table 113. TRANSIENT\_THS register**

tr_dbcntm	tr_ths[6:0]
0	7'b0000000

**Table 114. TRANSIENT\_THS bit descriptions**

Field	Description
tr_dbcntm	Debounce counter mode selection. 0: Decrements debounce counter when the transient event condition is not true during the current ODR period. 1: Clears debounce counter when the transient event condition is not true during the current ODR period.
tr_ths[6:0]	Transient event threshold. This register has a resolution of 63 mg/LSB regardless of the full-scale range setting made in XYZ_DATA_CFG[fs]. If CTRL_REG1[Inoise] = 1, the maximum acceleration measurement range is $\pm 4 g$ .

The tr\_ths[6:0] value is a 7-bit unsigned number, with a fixed resolution of 63 mg/LSB corresponding to a  $\pm 8 g$  measurement range. The resolution does not change with the full-scale range setting made in XYZ\_DATA\_CFG[fs]. If CTRL\_REG1[Inoise] = 1, the measurement range is fixed at  $\pm 4 g$ , regardless of the settings made in XYZ\_DATA\_CFG.

### 10.10.4 TRANSIENT\_COUNT (0x20) register

The TRANSIENT\_COUNT register sets the minimum number of debounce counts needed to trigger the transient event interrupt flag when the measured acceleration value exceeds the threshold set in TRANSIENT\_THS for any of the enabled axes.

**Table 115. TRANSIENT\_COUNT register**

tr_count[7:0]
8'b00000000

**Table 116. TRANSIENT\_COUNT bit description**

Field	Description
tr_count[7:0]	Transient function debounce count value.

The time step for the transient detection debounce counter is set by the value of the system ODR and power mode as shown in [Table 117](#).

**Table 117. TRANSIENT\_COUNT relationship with the ODR**

ODR (Hz)	Max time range (s)				Time step (ms)			
	Normal	LPLN	High resolution	Low power	Normal	LPLN	High resolution	Low power
800	0.319	0.319	0.319	0.319	1.25	1.25	1.25	1.25
400	0.638	0.638	0.638	0.638	2.5	2.5	2.5	2.5
200	1.28	1.28	0.638	1.28	5	5	2.5	5
100	2.55	2.55	0.638	2.55	10	10	2.5	10
50	5.1	5.1	0.638	5.1	20	20	2.5	20
12.5	5.1	20.4	0.638	20.4	20	80	2.5	80
6.25	5.1	20.4	0.638	40.8	20	80	2.5	160
1.56	5.1	20.4	0.638	40.8	20	80	2.5	160

An ODR of 100 Hz and a TRANSIENT\_COUNT value of 15, when accelerometer OSR is set to normal using CTRL\_REG2, would result in minimum debounce response time of 150 ms.

## 10.11 Pulse detection

### 10.11.1 PULSE\_CFG (0x21) register

This register configures the pulse event detection function.

**Table 118. PULSE\_CFG register**

pls_dpa	pls_ele	pls_zdpefe	pls_zspefe	pls_ydpefe	pls_yspefe	pls_xdpefe	pls_xspefe
0	0	0	0	0	0	0	0

**Table 119. PULSE\_CFG bit descriptions**

Field	Description
pls_dpa	Double-pulse abort. 0: Double-pulse detection is not aborted if the start of a pulse is detected during the time period specified by the PULSE_LTCY register. 1: Setting the <i>pls_dpa</i> bit momentarily suspends the double-tap detection if the start of a pulse is detected during the time period specified by the PULSE_LTCY register and the pulse ends before the end of the time period specified by the PULSE_LTCY register.
pls_ele	Pulse event flag latch enable. When enabled, a read of the PULSE_SRC register is needed to clear the event flag. 0: Event flag latch disabled 1: Event flag latch enabled
pls_zdpefe	Event flag enable on double-pulse event on Z-axis. 0: Event detection disabled 1: Raise event flag on detection of double-pulse event on Z-axis
pls_zspefe	Event flag enable on single-pulse event on Z-axis. 0: Event detection disabled 1: Raise event flag on detection of single-pulse event on Z-axis
pls_ydpefe	Event flag enable on double-pulse event on Y-axis. 0: Event detection disabled 1: Raise event flag on detection of double-pulse event on Y-axis
pls_yspefe	Event flag enable on single-pulse event on Y-axis. 0: Event detection disabled 1: Raise event flag on detection of single-pulse event on Z-axis.
pls_xdpefe	Event flag enable on double-pulse event on X-axis. 0: Event detection disabled 1: Raise event flag on detection of double-pulse event on X-axis.
pls_xspefe	Event flag enable on single-pulse event on X-axis. 0: Event detection disabled 1: Raise event flag on detection of single-pulse event on X-axis.

### 10.11.2 PULSE\_SRC (0x22) register

This register indicates the status bits for the pulse detection function.

**Table 120. PULSE\_SRC register**

pls_src_ea	pls_src_axz	pls_src_axy	pls_src_axx	pls_src_dpe	pls_src_polz	pls_src_poly	pls_src_polx
------------	-------------	-------------	-------------	-------------	--------------	--------------	--------------

**Table 121. PULSE\_SRC bit descriptions**

Field	Description
pls_src_ea	Event active flag. 0: No interrupt has been generated 1: One or more interrupt events have been generated
pls_src_axz	Z-axis event flag. 0: No interrupt. 1: Z-axis event has occurred
pls_src_axy	Y-axis event flag. 0: No interrupt. 1: Y-axis event has occurred
pls_src_axx	X-axis event flag. 0: No interrupt. 1: X-axis event has occurred.
pls_src_dpe	Double pulse on first event. 0: Single-pulse event triggered interrupt. 1: Double-pulse event triggered interrupt.
pls_src_polz	Pulse polarity of Z-axis event. 0: Pulse event that triggered interrupt was positive. 1: Pulse event that triggered interrupt was negative.
pls_src_poly	Pulse polarity of Y-axis event. 0: Pulse event that triggered interrupt was positive. 1: Pulse event that triggered interrupt was negative.
pls_src_polx	Pulse polarity of X-axis event. 0: Pulse event that triggered interrupt was positive. 1: Pulse event that triggered interrupt was negative.

### 10.11.3 PULSE\_THSX (0x23) register

**Table 122. PULSE\_THSX register**

—	pls_thsx[6:0]
0	7'b0000000

**Table 123. PULSE\_THSX bit description**

Field	Description
pls_thsx[6:0]	Pulse threshold for X-axis.

The PULSE\_THSX, PULSE\_THSY and PULSE\_THSZ registers define the thresholds used by the system to start the pulse-event detection procedure. Threshold values for each axis are unsigned 7-bit numbers with a fixed resolution of 0.063 g/LSB, corresponding to an 8 g acceleration full-scale range. The full-scale range is fixed at 8 g for the pulse detection function, regardless of the settings made in XYZ\_DATA\_CFG[fs].

### 10.11.4 PULSE\_THSY (0x24) register

Table 124. PULSE\_THSY register

—	pls_thsy[6:0]
0	7'b0000000

Table 125. PULSE\_THSY bit description

Field	Description
pls_thsy[6:0]	Pulse threshold for Y-axis.

### 10.11.5 PULSE\_THSZ (0x25) register

Table 126. PULSE\_THSZ register

—	pls_thsz[6:0]
0	7'b0000000

Table 127. PULSE\_THSZ bit description

Field	Description
pls_thsz[6:0]	Pulse threshold for Z-axis.

### 10.11.6 PULSE\_TMLT (0x26) register

Table 128. PULSE\_TMLT register

pls_tmlt[7:0]
8'b00000000

Table 129. PULSE\_TMLT bit description

Field	Description
pls_tmlt[7:0]	<i>pls_tmlt</i> [7:0] defines the maximum time interval that can elapse between the start of the acceleration on the selected channel exceeding the specified threshold and the end when the channel acceleration goes back below the specified threshold.

Minimum time step for the pulse-time limit is defined in [Tables 130](#) and [131](#). Maximum time for a given ODR is “Minimum time step x 255”.

Table 130. Time step for PULSE\_TMLT with HP\_FILTER\_CUTOFF[*pls\_hpf\_en*] = 1

ODR (Hz)	Max time range (s)				Time step (ms)			
	Normal	LPLN	High resolution	Low power	Normal	LPLN	High resolution	Low power
800	0.319	0.319	0.319	0.319	1.25	1.25	1.25	1.25
400	0.638	0.638	0.638	0.638	2.5	2.5	2.5	2.5
200	1.28	1.28	0.638	1.28	5	5	2.5	5
100	2.55	2.55	0.638	2.55	10	10	2.5	10
50	5.1	5.1	0.638	5.1	20	20	2.5	20
12.5	5.1	20.4	0.638	20.4	20	80	2.5	80
6.25	5.1	20.4	0.638	40.8	20	80	2.5	160
1.56	5.1	20.4	0.638	40.8	20	80	2.5	160

**Table 131. Time step for PULSE\_TMLT with HP\_FILTER\_CUTOFF[*pls\_hpf\_en*] = 0**

ODR (Hz)	Max time range (s)				Time step (ms)			
	Normal	LPLN	High resolution	Low power	Normal	LPLN	High resolution	Low power
800	0.159	0.159	0.159	0.159	0.625	0.625	0.625	0.625
400	0.159	0.159	0.159	0.319	0.625	0.625	0.625	1.25
200	0.319	0.319	0.159	0.638	1.25	1.25	0.625	2.5
100	0.638	0.638	0.159	1.28	2.5	2.5	0.625	5
50	1.28	1.28	0.159	2.55	5	5	0.625	10
12.5	1.28	5.1	0.159	10.2	5	20	0.625	40
6.25	1.28	5.1	0.159	10.2	5	20	0.625	40
1.56	1.28	5.1	0.159	10.2	5	20	0.625	40

Therefore an ODR setting of 400 Hz, when accelerometer OSR is set to normal using CTRL\_REG2, would result in a maximum pulse-time limit of (0.625 ms \* 255) = 159 ms.

### 10.11.7 PULSE\_LTCY (0x27) register

**Table 132. PULSE\_LTCY register**

pls_ltcy[7:0]
8'b00000000

**Table 133. PULSE\_LTCY bit description**

Field	Description
pls_ltcy[7:0]	<i>pls_ltcy</i> [7:0] defines the time interval that starts after the first pulse detection where the pulse-detection function ignores the start of a new pulse.

Minimum time step for the pulse latency is defined in [Tables 134](#) and [135](#). Maximum time is “(time step @ ODR and power mode) x 255”.

**Table 134. Time step for PULSE\_LTCY with HP\_FILTER\_CUTOFF[*pls\_hpf\_en*] = 1**

ODR (Hz)	Max time range (s)				Time step (ms)			
	Normal	LPLN	High resolution	Low power	Normal	LPLN	High resolution	Low power
800	0.638	0.638	0.638	0.638	2.5	2.5	2.5	2.5
400	1.276	1.276	1.276	1.276	5	5	5	5
200	2.56	2.56	1.276	2.56	10	10	5	10
100	5.1	5.1	1.276	5.1	20	20	5	20
50	10.2	10.2	1.276	10.2	40	40	5	40
12.5	10.2	40.8	1.276	40.8	40	160	5	160
6.25	10.2	40.8	1.276	81.6	40	160	5	320
1.56	10.2	40.8	1.276	81.6	40	160	5	320



**Table 135. Time step for PULSE\_LTCY with HP\_FILTER\_CUTOFF[pls\_hpf\_en] = 0**

ODR (Hz)	Max time range (s)				Time step (ms)			
	Normal	LPLN	High resolution	Low power	Normal	LPLN	High resolution	Low power
800	0.318	0.318	0.318	0.318	1.25	1.25	1.25	1.25
400	0.318	0.318	0.318	0.638	1.25	1.25	1.25	2.5
200	0.638	0.638	0.318	1.276	2.5	2.5	1.25	5
100	1.276	1.276	0.318	2.56	5	5	1.25	10
50	2.56	2.56	0.318	5.1	10	10	1.25	20
12.5	2.56	10.2	0.318	20.4	10	40	1.25	80
6.25	2.56	10.2	0.318	20.4	10	40	1.25	80
1.56	2.56	10.2	0.318	20.4	10	40	1.25	80

**10.11.8 PULSE\_WIND (0x28) register**

**Table 136. PULSE\_WIND register**

pls_wind[7:0]
8'b00000000

**Table 137. PULSE\_WIND bit description**

Field	Description
pls_wind[7:0]	pls_wind[7:0] defines the maximum interval of time that can elapse after the end of the latency interval in which the start of the second pulse event must be detected provided the device has been configured for double pulse detection. The detected second pulse width must be shorter than the time limit constraint specified by the PULSE_TMLT register, but the end of the double pulse need not finish within the time specified by the PULSE_WIND register.

The time step for the pulse-window counter varies with the selected ODR and power modes as defined in [Tables 138](#) and [139](#). The maximum time value is equal to (time step @ ODR and power mode) x 255.

**Table 138. Time step for PULSE\_WIND with HP\_FILTER\_CUTOFF[pls\_hpf\_en] = 1**

ODR (Hz)	Max time range (s)				Time step (ms)			
	Normal	LPLN	High resolution	Low power	Normal	LPLN	High resolution	Low power
800	0.638	0.638	0.638	0.638	2.5	2.5	2.5	2.5
400	1.276	1.276	1.276	1.276	5	5	5	5
200	2.56	2.56	1.276	2.56	10	10	5	10
100	5.1	5.1	1.276	5.1	20	20	5	20
50	10.2	10.2	1.276	10.2	40	40	5	40
12.5	10.2	40.8	1.276	40.8	40	160	5	160
6.25	10.2	40.8	1.276	81.6	40	160	5	320
1.56	10.2	40.8	1.276	81.6	40	160	5	320

**Table 139. Time step for PULSE\_WIND with HP\_FILTER\_CUTOFF[plis\_hpf\_en] = 0**

ODR (Hz)	Max time range (s)				Time step (ms)			
	Normal	LPLN	High resolution	Low power	Normal	LPLN	High resolution	Low power
800	0.318	0.318	0.318	0.318	1.25	1.25	1.25	1.25
400	0.318	0.318	0.318	0.638	1.25	1.25	1.25	2.5
200	0.638	0.638	0.318	1.276	2.5	2.5	1.25	5
100	1.276	1.276	0.318	2.56	5	5	1.25	10
50	2.56	2.56	0.318	5.1	10	10	1.25	20
12.5	2.56	10.2	0.318	20.4	10	40	1.25	80
6.25	2.56	10.2	0.318	20.4	10	40	1.25	80
1.56	2.56	10.2	0.318	20.4	10	40	1.25	80

## 10.12 Offset correction

The 8-bit 2's complement offset correction registers are used to remove the sensor zero *g* offset on the X, Y, and Z axes after device board mount. The resolution of the offset registers is 2 mg per LSB, with an effective offset adjustment range of -256 mg to +254 mg for each axis.

For more information on how to calibrate the 0 *g* offset, please refer to Freescale application note AN4069.

### 10.12.1 OFF\_X (0x2F) register

**Table 140. OFF\_X register**

off_x[7:0]
8'b00000000

**Table 141. OFF\_X bit description**

Field	Description
off_x[7:0]	X-axis offset correction value expressed as an 8-bit 2's complement number.

### 10.12.2 OFF\_Y (0x30) register

**Table 142. OFF\_Y register**

off_y[7:0]
8'b00000000

**Table 143. OFF\_Y bit description**

Field	Description
off_y[7:0]	Y-axis offset correction value expressed as an 8-bit 2's complement number.

### 10.12.3 OFF\_Z (0x31) register

**Table 144. OFF\_Z register**

off_z[7:0]
8'b00000000

**Table 145. OFF\_Z bit description**

Field	Description
off_z[7:0]	Z-axis offset correction value expressed as an 8-bit 2's complement number.

## 11 Mounting Guidelines for the Quad Flat No-Lead (QFN) Package

Printed Circuit Board (PCB) layout is a critical portion of the total design. The footprint for the surface mount packages must be the correct size to ensure proper solder connection interface between the PCB and the package. With the correct footprint, the packages will self-align when subjected to a solder reflow process.

These guidelines are for soldering and mounting the Quad Flat No-Lead (QFN) package inertial sensors to PCBs. The purpose is to minimize the stress on the package after board mounting. The FXLS8471Q uses the QFN package platform. This section describes suggested methods of soldering these devices to the PCB for consumer applications.

Freescale application note AN1902, "Quad Flat Pack No-Lead (QFN) Micro Dual Flat Pack No-Lead (DFN)" discusses the QFN package used by the FXLS8471Q, PCB design guidelines for using QFN packages and temperature profiles for reflow soldering.

### 11.1 Overview of soldering considerations

Information provided here is based on experiments executed on QFN devices. As they cannot represent exact conditions present at a customer site, the information provided herein should be used for guidance only and further process and design optimizations are recommended to develop an application specific solution. It should be noted that with the proper PCB footprint and solder stencil designs, the package will self-align during the solder reflow process.

### 11.2 Halogen content

This package is designed to be Halogen Free, exceeding most industry and customer standards. Halogen Free means that no homogeneous material within the assembled package will contain chlorine (Cl) in excess of 700 ppm or 0.07% weight/weight or bromine (Br) in excess of 900 ppm or 0.09% weight/weight.

### 11.3 PCB mounting recommendations

1. The PCB land should be designed with Non-Solder Mask Defined (NSMD) as shown in [Figure 18](#) and [Figure 19](#).
2. No additional via pattern underneath package.
3. PCB land pad is 0.8 mm by 0.3 mm as shown in [Figure 18](#) and [Figure 19](#).
4. Solder mask opening = PCB land pad edge + 0.113 mm larger all around.
5. Stencil opening = PCB land pad - 0.015 mm smaller all around = 0.77 mm by 0.27 mm.
6. Stencil thickness is 100 or 125  $\mu\text{m}$ .
7. Do not place any components or vias at a distance less than 2 mm from the package land area. This may cause additional package stress if it is too close to the package land area.
8. Signal traces connected to pads should be as symmetric as possible. Put dummy traces on the NC pads in order to have same length of exposed trace for all pads.
9. Use a standard pick and place process and equipment. Do not use a hand soldering process.
10. Do not use a screw down or stacking to fix the PCB into an enclosure as this could bend the PCB, putting stress on the package.
11. The PCB should be rated for the multiple lead-free reflow condition with max 260°C temperature.
12. No copper traces on top layer of PCB under the package. This will cause planarity issues with board mount. Freescale QFN sensors are compliant with Restrictions on Hazardous Substances (RoHS), having halide-free molding compound (green) and lead-free terminations. These terminations are compatible with tin-lead (Sn-Pb) as well as tin-silver-copper (Sn-Ag-Cu) solder paste soldering processes. Reflow profiles applicable to those processes can be used successfully for soldering the devices.

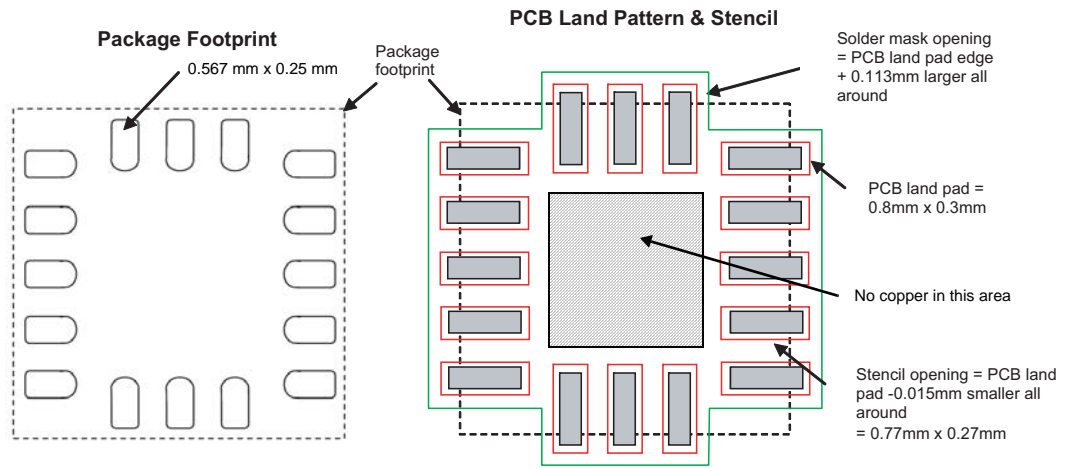

**Figure 18. Recommended PCB land pattern, solder mask, and stencil opening near package footprint**

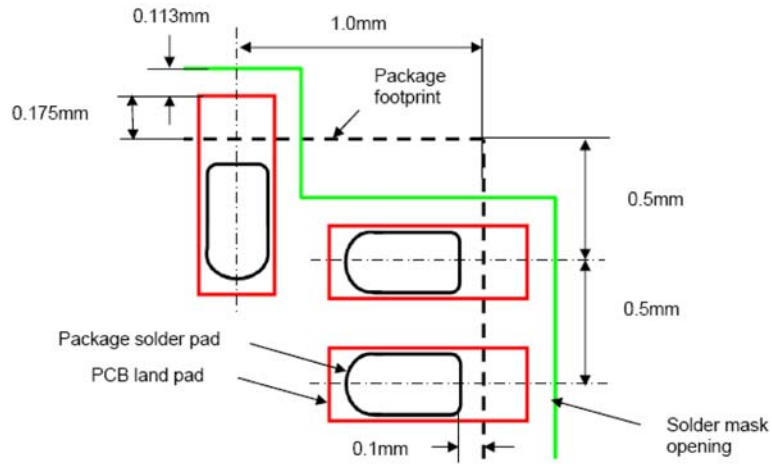

**Figure 19. Detailed dimensions**

## 12 Package Thermal Characteristics

**Table 146. Thermal resistance data**

Rating	Description	Symbol	Value	Unit
Junction-to-ambient, natural convection <sup>(1)(2)</sup>	Single-layer board	$R_{\theta JA}$	163	°C/W
Junction-to-ambient, natural convection <sup>(1)(3)</sup>	Four-layer board (two signals, two planes)		70	
Junction-to-board <sup>(4)</sup>		$R_{\theta JB}$	33	°C/W
Junction-to-case (top) <sup>(5)</sup>		$R_{\theta JCTop}$	84	°C/W
Junction-to-package (top) <sup>(6)</sup>	Natural convection	$\Psi_{JT}$	6	°C/W

1. Junction temperature is a function of die size, on-chip power dissipation, package thermal resistance, mounting site (board) temperature, ambient temperature, air flow, power dissipation of other components on the board, and board thermal resistance.
2. Per JEDEC JESD51-2 with the single-layer board (JESD51-3) horizontal.
3. Per JEDEC JESD51-6 with the board (JESD51-7) horizontal.
4. Thermal resistance between the die and the printed circuit board per JEDEC JESD51-8. Board temperature is measured on the top surface of the board near the package.
5. Thermal resistance between the die and the case top surface as measured by the cold plate method (MIL SPEC-883 Method 1012.1).
6. Thermal characterization parameter indicating the temperature difference between package top and the junction temperature per JEDEC JESD51-2. When Greek letters are not available, the thermal characterization parameter is written as Psi-JT.

# 13 Package

This drawing is located at [http://cache.freescale.com/files/shared/doc/package\\_info/98ASA00063D.pdf](http://cache.freescale.com/files/shared/doc/package_info/98ASA00063D.pdf).

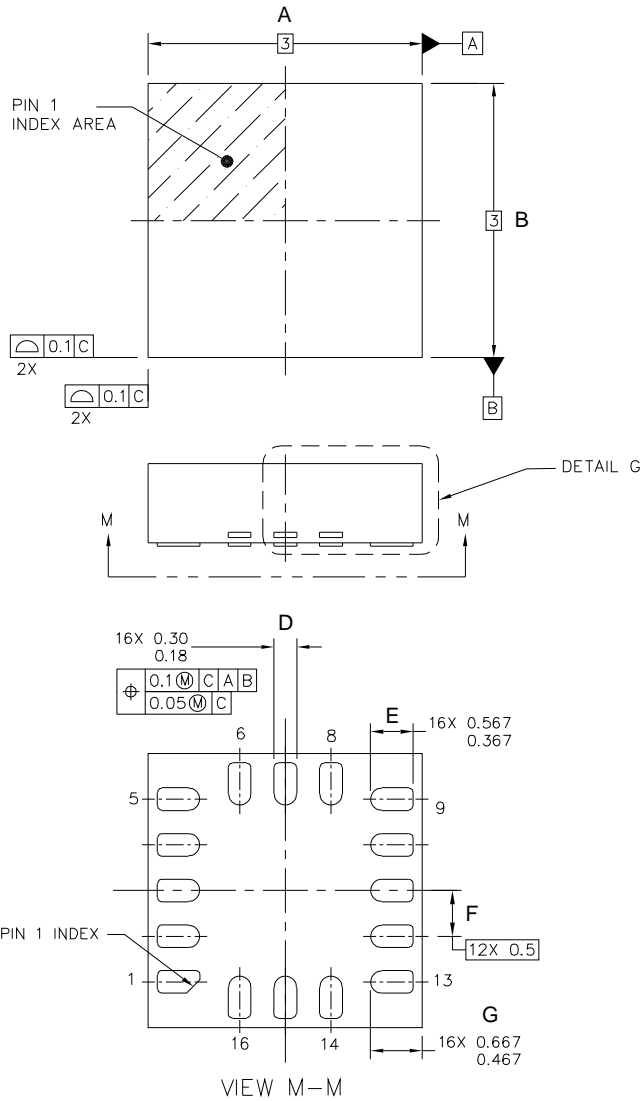

© FREESCALE SEMICONDUCTOR, INC. ALL RIGHTS RESERVED.	<b>MECHANICAL OUTLINE</b>	PRINT VERSION NOT TO SCALE	
TITLE: QUAD FLAT NO LEAD COL PACKAGE (QFN-COL) 16 TERMINAL, 0.5 PITCH (3 X 3 X 1.0)	DOCUMENT NO: 98ASA00063D	REV: A	
	CASE NUMBER: 2077-02	20 OCT 2011	
	STANDARD: NON JEDEC		

**CASE 2077-02  
ISSUE A  
16-LEAD QFN**

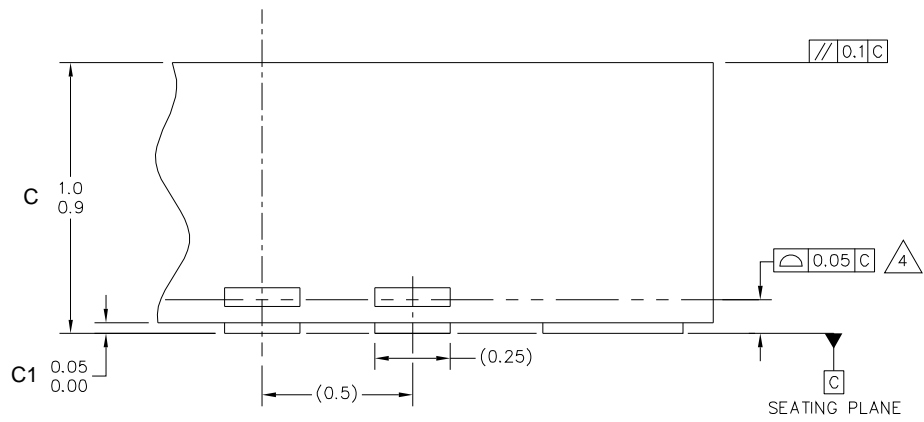

DETAIL G

© FREESCALE SEMICONDUCTOR, INC. ALL RIGHTS RESERVED.	<b>MECHANICAL OUTLINE</b>	PRINT VERSION NOT TO SCALE	
TITLE: QUAD FLAT NO LEAD COL PACKAGE (QFN-COL) 16 TERMINAL, 0.5 PITCH (3 X 3 X 1.0)	DOCUMENT NO: 98ASA00063D	REV: A	
	CASE NUMBER: 2077-02	20 OCT 2011	
	STANDARD: NON JEDEC		

**CASE 2077-02  
ISSUE A  
16-LEAD QFN**

**FXLS8471Q**

**Table 147. Package dimensions (mm)**

Symbol	Description	Min	Typ	Max
A	Package width	2.9	3	3.1
B	Package length	2.9	3	3.1
C	Package thickness	0.9	0.98	1
C1	Lead finger (pad) seating height	0	—	0.05
D	Lead finger (pad) width	0.18	0.25	0.30
E	Lead length	0.367	0.467	0.567
F	Lead finger-finger (pad-pad) pitch	—	0.5	—
G	Package edge to inner edge of lead	0.467	0.567	0.667

NOTES:

1. ALL DIMENSIONS ARE IN MILLIMETERS.
2. INTERPRET DIMENSIONS AND TOLERANCES PER ASME Y14.5M-1994.
3. THIS IS NON JEDEC REGISTERED PACKAGE.
4.  COPLANARITY APPLIES TO ALL LEADS.
5. MIN. METAL GAP SHOULD BE 0.2MM.

© FREESCALE SEMICONDUCTOR, INC. ALL RIGHTS RESERVED.	<b>MECHANICAL OUTLINE</b>	PRINT VERSION NOT TO SCALE	
TITLE: QUAD FLAT NO LEAD COL PACKAGE (QFN-COL) 16 TERMINAL, 0.5 PITCH (3 X 3 X 1.0)	DOCUMENT NO: 98ASA00063D	REV: A	
	CASE NUMBER: 2077-02	20 OCT 2011	
	STANDARD: NON JEDEC		

**CASE 2077-02  
ISSUE A  
16-LEAD QFN**



# Appendix A

## A.1 Errata

### A.1.1 SPI Mode Soft-reset using CTRL\_REG2 (0x2B), bit 6

**Description:**

Following a soft-reset command, issued by setting CTRL\_REG2[rsf] = 1, certain device-specific parameters do not get updated correctly from NVM, causing inaccurate data output and incorrect WHOAMI (0x0D) register content. This behavior happens only in SPI mode. In I<sup>2</sup>C mode the device works as advertised.

**Workaround:**

Avoid using soft-reset in SPI mode by alternately utilizing the hardware RESET pin.

## 14 Revision History

Table 148. Revision history

Revision number	Revision date	Description of changes
1.0	8/2013	<ul style="list-style-type: none"><li>Initial data sheet.</li></ul>
1.1	8/2013	<ul style="list-style-type: none"><li>Global update: "counts/g" changed to "LSB/g" throughout document.</li><li>Table 2: Updated Min values for Self-Test output change, X, Y, and Z from +249, +335, and +1680 to +192, +270, and +1275 respectively.</li><li>Appendix A.1.1: Corrected register name in Description paragraph.</li></ul>
1.2	11/2014	<ul style="list-style-type: none"><li>Added Ordering Information table on page 2.</li></ul>
1.3	01/2015	<ul style="list-style-type: none"><li>Added callouts to the package drawing and dimension table following package drawing.</li></ul>
1.4	03/2015	<ul style="list-style-type: none"><li>Table 147: Added Typ dimensions for Symbol C and E.</li></ul>
1.5	06/2015	<ul style="list-style-type: none"><li>Added G callout to package drawing and dimension table following package drawing.</li></ul>

**How to Reach Us:**

**Home Page:**

freescale.com

**Web Support:**

freescale.com/support

Information in this document is provided solely to enable system and software implementers to use Freescale products. There are no express or implied copyright licenses granted hereunder to design or fabricate any integrated circuits based on the information in this document.

Freescale reserves the right to make changes without further notice to any products herein. Freescale makes no warranty, representation, or guarantee regarding the suitability of its products for any particular purpose, nor does Freescale assume any liability arising out of the application or use of any product or circuit, and specifically disclaims any and all liability, including without limitation consequential or incidental damages. "Typical" parameters that may be provided in Freescale data sheets and/or specifications can and do vary in different applications, and actual performance may vary over time. All operating parameters, including "typicals," must be validated for each customer application by customer's technical experts. Freescale does not convey any license under its patent rights nor the rights of others. Freescale sells products pursuant to standard terms and conditions of sale, which can be found at the following address: [freescale.com/salestermsandconditions](http://freescale.com/salestermsandconditions).

Freescale, the Freescale logo, and the Energy Efficient Solutions logo are trademarks of Freescale Semiconductor, Inc., Reg. U.S. Pat. & Tm. Off. All other product or service names are the property of their respective owners.

© 2013-2015 Freescale Semiconductor, Inc.

Document Number: FXLS8471Q

Rev. 1.5

06/2015

