



1.0 Key Features

- Extremely flexible and low-jitter phase locked loop (PLL) frequency synthesis
- No external loop filter components needed
- 150MHz CMOS or 340MHz PECL outputs
- Completely configurable via I²C™-bus
- Up to four FS714x can be used on a single I²C-bus
- 3.3V operation
- Independent on-chip crystal oscillator and external reference input
- Very low “cumulative” jitter

2.0 Description

The FS714x (FS7140x or FS7145x) is a monolithic CMOS clock generator/regenerator IC designed to minimize cost and component count in a variety of electronic systems. Via the I²C-bus interface, the FS714x can be adapted to many clock generation requirements.

The length of the reference and feedback dividers, their fine granularity and the flexibility of the post divider make the FS714x the most flexible stand-alone PLL clock generator available.

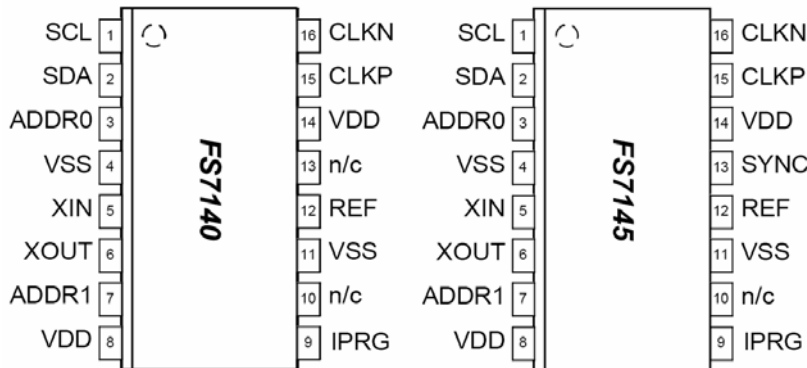

Figure 1: Pin Configuration: 16-pin (0.150") SOIC, 16-pin (5.3mm) SSOP

3.0 Applications

- Precision frequency synthesis
- Low-frequency clock multiplication
- Video line-locked clock generation
- Laser beam printers (FS7145)

FS714x

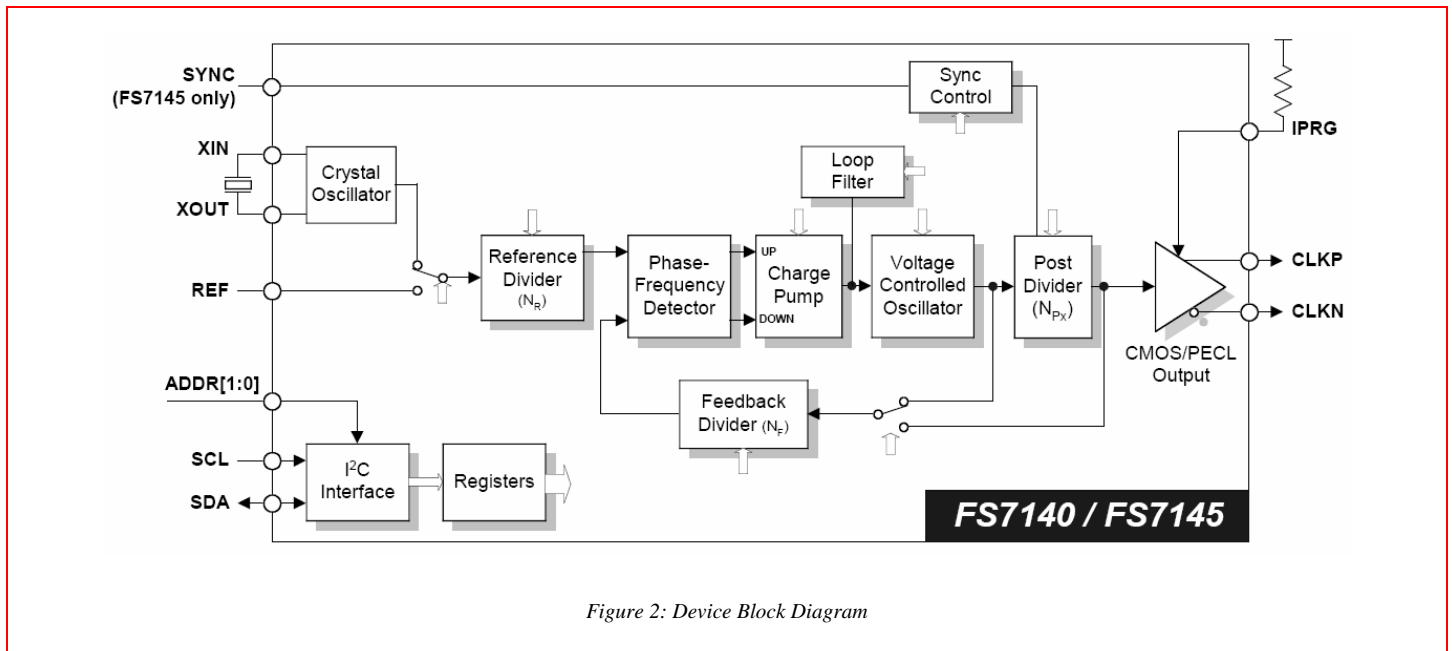

Figure 2: Device Block Diagram

Table 1: FS7140 Pin Descriptions

Pin	Type	Name	Description
1	DI	SCL	Serial interface clock (requires an external pull-up)
2	DIO	SDA	Serial interface data input/output (requires an external pull-up)
3	DI _b	ADDR0	Address select bit "0"
4	P	VSS	Ground
5	AI	XIN	Crystal oscillator feedback
6	AO	XOUT	Crystal oscillator drive
7	DI _b	ADDR1	Address select bit "1"
8	P	VDD	Power supply (+3.3V nominal)
9	AI	IPRG	PECL current drive programming
10	-	n/c	No connection
11	P	VSS	Ground
12	DI ^U	REF	Reference frequency input
13	-	n/c	No connection
14	P	VDD	Power supply (+3.3V nominal)
15	DO	CLKP	Clock output
16	DO	CLKN	Inverted clock output

Key: AI: Analog Input; AO = Analog Output; DI = Digital Input; DI^U = Input with Internal Pull-up; DI_b = Input with Internal Pull-down; DIO = Digital Input/Output; DI-3 = Three-Level Digital Input; DO = Digital Output; P = Power/Ground; # = Active Low Pin

FS714x

Table 2: FS7145 Pin Descriptions

Pin	Type	Name	Description
1	DI	SCL	Serial interface clock (requires an external pull-up)
2	DIO	SDA	Serial interface data input/output (requires an external pull-up)
3	DI _b	ADDR0	Address select bit "0"
4	P	VSS	Ground
5	AI	XIN	Crystal oscillator feedback
6	AO	XOUT	Crystal oscillator drive
7	DI _b	ADDR1	Address select bit "1"
8	P	VDD	Power supply (+3.3V nominal)
9	AI	IPRG	PECL current drive programming
10	-	n/c	No connection
11	P	VSS	Ground
12	DI ^U	REF	Reference frequency input
13	DI ^U	SYNC	Synchronization input
14	P	VDD	Power supply (+3.3V nominal)
15	DO	CLKP	Clock output
16	DO	CLKN	Inverted clock output

Key: AI: Analog Input; AO = Analog Output; DI = Digital Input; DI^U = Input with Internal Pull-up; DI_b = Input with Internal Pull-down; DIO = Digital Input/Output; DI-3 = Three-Level Digital Input; DO = Digital Output; P = Power/Ground; # = Active Low Pin

4.0 Functional Block Diagram

4.1 Phase Locked Loop (PLL)

The PLL is a standard phase- and frequency-locked loop architecture. The PLL consists of a reference divider, a phase-frequency detector (PFD), a charge pump, an internal loop filter, a voltage-controlled oscillator (VCO), a feedback divider, and a post divider.

The reference frequency (generated by either the on-board crystal oscillator or an external frequency source), is first reduced by the reference divider. The integer value that the frequency is divided by is called the modulus and is denoted as N_R for the reference divider. This divided reference is then fed into the PFD.

The VCO frequency is fed back to the PFD through the feedback divider (the modulus is denoted by N_F).

The PFD will drive the VCO up or down in frequency until the divided reference frequency and the divided VCO frequency appearing at the inputs of the PFD are equal. The input/output relationship between the reference frequency and the VCO frequency is then:

$$\frac{f_{VCO}}{N_F} = \frac{f_{REF}}{N_R}$$

This basic PLL equation can be rewritten as

$$f_{VCO} = f_{REF} \left(\frac{N_F}{N_R} \right)$$

A post divider (actually a series combination of three post dividers) follows the PLL and the final equation for device output frequency is:

$$f_{CLK} = f_{REF} \left(\frac{N_F}{N_R} \right) \left(\frac{1}{N_{Px}} \right)$$

FS714x

4.1.1. Reference Divider

The reference divider is designed for low phase jitter. The divider accepts the output of either the crystal oscillator circuit or an external reference frequency. The reference divider is a 12 bit divider, and can be programmed for any modulus from 1 to 4095 (divide by 1 not available on date codes prior to 0108).

4.1.2. Feedback Divider

The feedback divider is based on a dual-modulus divider (also called dual-modulus prescaler) technique. It permits division by any integer value between 12 and 16383. Simply program the FBKDIV register with the binary equivalent of the desired modulus. Selected moduli below 12 are also permitted. Moduli of: 4, 5, 8, 9, and 10 are also allowed (4 and 5 are not available on date codes prior to 0108).

4.1.3. Post Divider

The post divider consists of three individually programmable dividers, as shown in Figure 3.

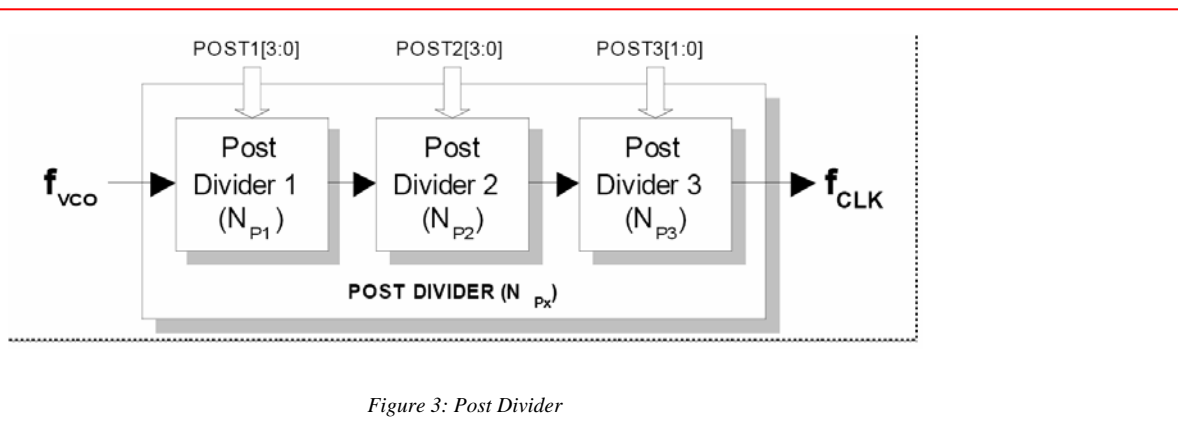

Figure 3: Post Divider

The moduli of the individual dividers are denoted as N_{P1}, N_{P2} and N_{P3}, and together they make up the array modulus N_{PX}.

$$N_{PX} = N_{P1} \times N_{P2} \times N_{P3}$$

The post divider performs several useful functions. First, it allows the VCO to be operated in a narrower range of speeds compared to the variety of output clock speeds that the device is required to generate. Second, the extra integer in the denominator permits more flexibility in the programming of the loop for many applications where frequencies must be achieved exactly.

Note that a nominal 50/50 duty factor is always preserved (even for selections which have an odd modulus).

See Table 8 for additional information.

4.1.4. Crystal Oscillator

The FS7140 is equipped with a Pierce-type crystal oscillator. The crystal is operated in parallel resonant mode. Internal load capacitance is provided for the crystal. While a recommended load capacitance for the crystal is specified, crystals for other standard load capacitances may be used if great precision of the reference frequency (100ppm or less) is not required.

4.1.5. Reference Divider Source MUX

The source of frequency for the reference divider can be chosen to be the device crystal oscillator or the REF pin by the REFDSRC bit.

When not using the crystal oscillator, it is preferred to connect XIN to VSS. Do not connect to XOUT.

FS714x

When not using the REF input, it is preferred to leave it floating or connected to V_{DD} .

4.1.6. Feedback Divider Source MUX

The source of frequency for the feedback divider may be selected to be either the output of the post divider or the output of the VCO by the FBKDSRC bit.

Ordinarily, for frequency synthesis, the output of the VCO is used. Use the output of the post divider only where a deterministic phase relationship between the output clock and reference clock are desired (line-locked mode, for example).

4.1.7. Device Shutdown

Two bits are provided to effect shutdown of the device if desired, when it is not active. SHUT1 disables most externally observable device functions. SHUT2 reduces device quiescent current to absolute minimum values. Normally, both bits should be set or cleared together.

Serial communications capability is not disabled by either SHUT1 or SHUT2.

4.2 Differential Output Stage

The differential output stage supports both CMOS and pseudo-ECL (PECL) signals. The desired output interface is chosen via the programming registers.

If a PECL interface is used, the transmission line is usually terminated using a Thévenin termination. The output stage can only sink current in the PECL mode, and the amount of sink current is set by a programming resistor on the LOCK/IPRG pin. The ratio of output sink current to IPRG current is 13:1. Source current for the CLKx pins is provided by the pull-up resistors that are part of the Thévenin termination.

4.2.1. Example

Assume that it is desired to connect a PECL-type fanout buffer right next to the FS7140.

Further assume:

- $V_{DD} = 3.3V$
- Desired $V_{HI} = 2.4V$
- Desired $V_{LO} = 1.6V$
- Equivalent $R_{LOAD} = 75\text{ ohms}$

FS714x

Then:

$$\begin{aligned} R1 \text{ (from CLKP and CLKN output to VDD)} &= \\ R_{LOAD} * V_{DD} / V_{HI} &= \\ 75 * 3.3 / 2.4 &= \\ 103 \text{ ohms} & \end{aligned}$$

$$\begin{aligned} R2 \text{ (from CLKP and CLKN output to GND)} &= \\ R_{LOAD} * V_{DD} / (V_{DD} - V_{HI}) &= \\ 75 * 3.3 / (3.3 - 2.4) &= \\ 275 \text{ ohms} & \end{aligned}$$

$$\begin{aligned} R_{prgm} \text{ (from VDD to IPRG pin)} &= \\ 26 * (V_{DD} * R_{LOAD}) / (V_{HI} - V_{LO}) / 3 &= \\ 26 * (3.3 * 75) / (2.4 - 1.6) / 3 &= \\ 2.68 \text{ Kohms} & \end{aligned}$$

4.3 SYNC Circuitry

The FS7145 supports nearly instantaneous adjustment of the output CLK phase by the SYNC input. Either edge direction of SYNC (positive-going or negative-going) is supported.

Example (positive-going SYNC selected): Upon the negative edge of SYNC input, a sequence begins to stop the CLK output. Upon the positive edge, CLK resumes operation, synchronized to the phase of the SYNC input (plus a deterministic delay). This is performed by control of the device post-divider. Phase resolution equal to 1/2 of the VCO period can be achieved (approximately down to 2ns).

5.0 I²C-bus Control Interface



This device is a read/write slave device meeting all Philips I²C-bus specifications except a "general call." The bus has to be controlled by a master device that generates the serial clock SCL, controls bus access and generates the START and STOP conditions while the device works as a slave. Both master and slave can operate as a transmitter or receiver, but the master device determines which mode is activated. A device that sends data onto the bus is defined as the transmitter, and a device receiving data as the receiver.

I²C-bus logic levels noted herein are based on a percentage of the power supply (V_{DD}). A logic-one corresponds to a nominal voltage of V_{DD}, while a logic-zero corresponds to ground (V_{SS}).

5.1 Bus Conditions

Data transfer on the bus can only be initiated when the bus is not busy. During the data transfer, the data line (SDA) must remain stable whenever the clock line (SCL) is high. Changes in the data line while the clock line is high will be interpreted by the device as a START or STOP condition. The following bus conditions are defined by the I²C-bus protocol.

5.1.1. Not Busy

Both the data (SDA) and clock (SCL) lines remain high to indicate the bus is not busy.

5.1.2. START Data Transfer

A high to low transition of the SDA line while the SCL input is high indicates a START condition. All commands to the device must be preceded by a START condition.

FS714x

5.1.3. STOP Data Transfer

A low to high transition of the SDA line while SCL input is high indicates a STOP condition. All commands to the device must be followed by a STOP condition.

5.1.4. Data Valid

The state of the SDA line represents valid data if the SDA line is stable for the duration of the high period of the SCL line after a START condition occurs. The data on the SDA line must be changed only during the low period of the SCL signal. There is one clock pulse per data bit.

Each data transfer is initiated by a START condition and terminated with a STOP condition. The number of data bytes transferred between START and STOP conditions is determined by the master device, and can continue indefinitely. However, data that is overwritten to the device after the first eight bytes will overflow into the first register, then the second, and so on, in a first-in, first-overwritten fashion.

5.1.5. Acknowledge

When addressed, the receiving device is required to generate an acknowledge after each byte is received. The master device must generate an extra clock pulse to coincide with the acknowledge bit. The acknowledging device must pull the SDA line low during the high period of the master acknowledge clock pulse. Setup and hold times must be taken into account.

The master must signal an end of data to the slave by not generating an acknowledge bit on the last byte that has been read (clocked) out of the slave. In this case, the slave must leave the SDA line high to enable the master to generate a STOP condition.

5.2 I²C-bus Operation

All programmable registers can be accessed randomly or sequentially via this bi-directional two wire digital interface. The crystal oscillator does not have to run for communication to occur.

The device accepts the following I²C-bus commands:

5.2.1. Slave Address

After generating a START condition, the bus master broadcasts a seven-bit slave address followed by a R/W bit. The address of the device is:

A6	A5	A4	A3	A2	A1	A0
1	0	1	1	0	X	X

where X is controlled by the logic level at the ADDR pins. The selectable ADDR bits allow four different FS7140 devices to exist on the same bus. Note that every device on an I²C-bus must have a unique address to avoid possible bus conflicts.

5.2.2. Random Register Write Procedure

Random write operations allow the master to directly write to any register. To initiate a write procedure, the R/W bit that is transmitted after the seven-bit device address is a logic-low. This indicates to the addressed slave device that a register address will follow after the slave device acknowledges its device address. The register address is written into the slave's address pointer. Following an acknowledge by the slave, the master is allowed to write eight bits of data into the addressed register. A final acknowledge is returned by the device, and the master generates a STOP condition.

If either a STOP or a repeated START condition occurs during a register write, the data that has been transferred is ignored.

FS714x

5.2.3. Random Register Read Procedure

Random read operations allow the master to directly read from any register. To perform a read procedure, the R/W bit that is transmitted after the seven-bit address is a logic-low, as in the register write procedure. This indicates to the addressed slave device that a register address will follow after the slave device acknowledges its device address. The register address is then written into the slave's address pointer.

Following an acknowledge by the slave, the master generates a repeated START condition. The repeated START terminates the write procedure, but not until after the slave's address pointer is set. The slave address is then resent, with the R/W bit set this time to a logic-high, indicating to the slave that data will be read. The slave will acknowledge the device address, and then transmits the eight-bit word. The master does not acknowledge the transfer but does generate a STOP condition.

5.2.4. Sequential Register Write Procedure

Sequential write operations allow the master to write to each register in order. The register pointer is automatically incremented after each write. This procedure is more efficient than the random register write if several registers must be written.

To initiate a write procedure, the R/W bit that is transmitted after the seven-bit device address is a logic-low. This indicates to the addressed slave device that a register address will follow after the slave device acknowledges its device address. The register address is written into the slave's address pointer. Following an acknowledge by the slave, the master is allowed to write up to eight bytes of data into the addressed register before the register address pointer overflows back to the beginning address.

An acknowledge by the device between each byte of data must occur before the next data byte is sent.

Registers are updated every time the device sends an acknowledge to the host. The register update does not wait for the STOP condition to occur. Registers are therefore updated at different times during a sequential register write.

5.2.5. Sequential Register Read Procedure

Sequential read operations allow the master to read from each register in order. The register pointer is automatically incremented by one after each read. This procedure is more efficient than the random register read if several registers must be read.

To perform a read procedure, the R/W bit that is transmitted after the seven-bit address is a logic-low, as in the register write procedure. This indicates to the addressed slave device that a register address will follow after the slave device acknowledges its device address. The register address is then written into the slave's address pointer.

Following an acknowledge by the slave, the master generates a repeated START condition. The repeated START terminates the write procedure, but not until after the slave's address pointer is set. The slave address is then resent, with the R/W bit set this time to a logic-high, indicating to the slave that data will be read. The slave will acknowledge the device address, and then transmits all eight bytes of data starting with the initial addressed register. The register address pointer will overflow if the initial register address is larger than zero. After the last byte of data, the master does not acknowledge the transfer but does generate a STOP condition.

FS714x

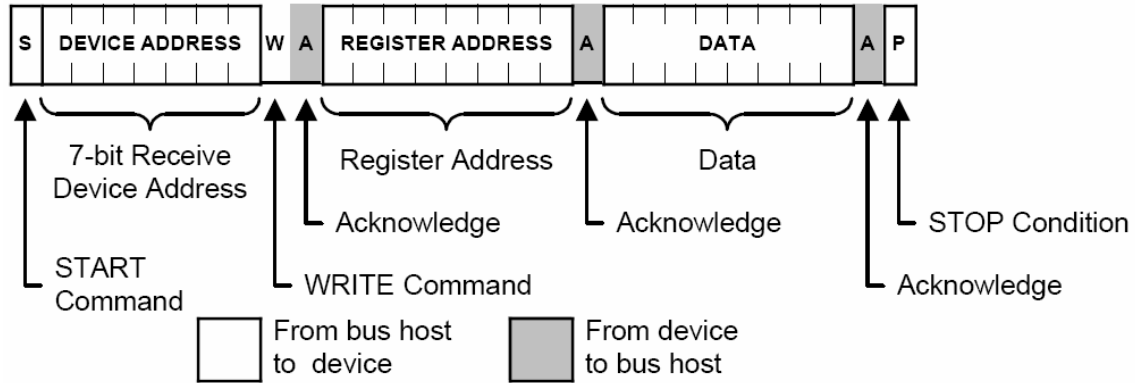

Figure 4: Random Register Write Procedure

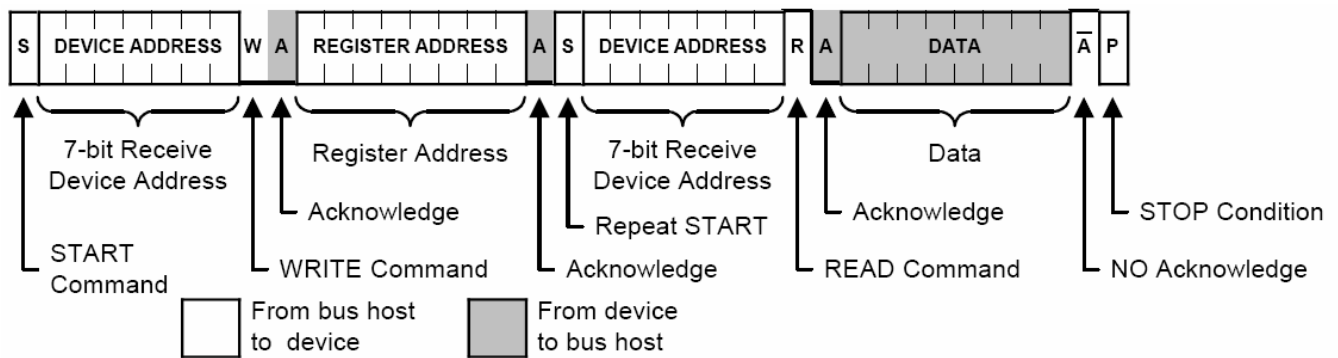

Figure 5: Random Register Read Procedure

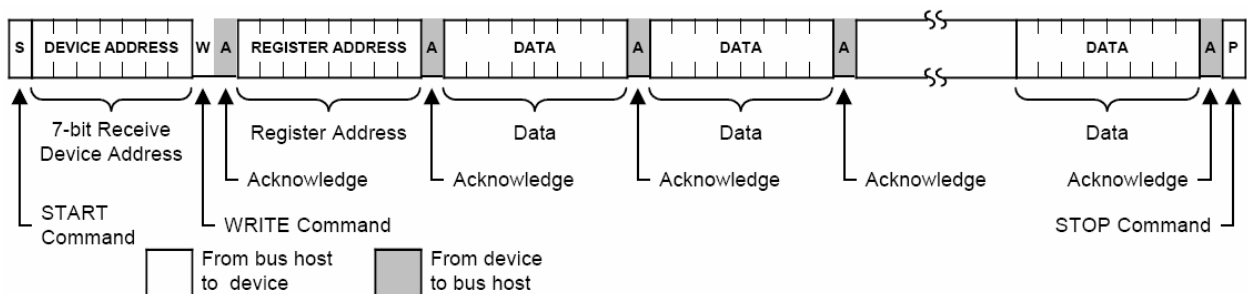

Figure 6: Sequential Register Write Procedure

FS714x

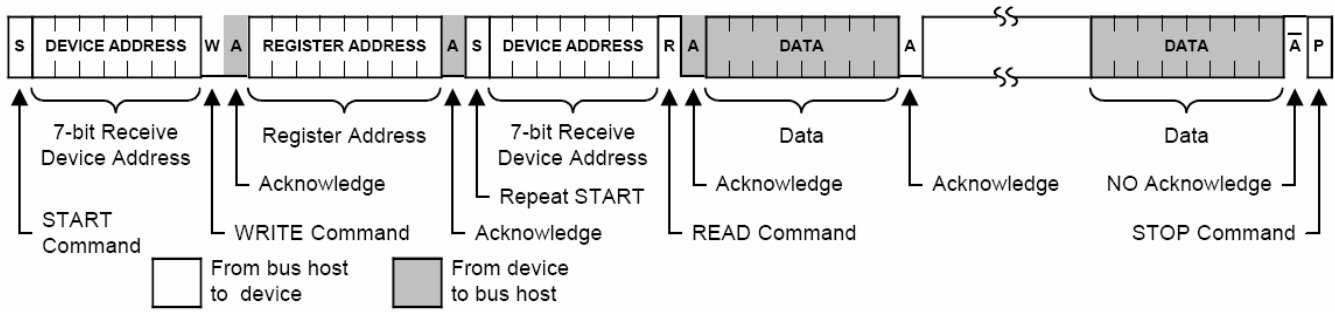

Figure 7: Sequential Register Read Procedure

FS714x

6.0 Programming Information

All register bits are cleared to zero on power-up. All register bits may be read back as written.

Table 3: FS7140 Register Map

Address	BIT 7	BIT 6	BIT 5	BIT 4	BIT 3	BIT 2	BIT 1	BIT 0
Byte 7	Reserved (Bit 63) <i>Must be set to "0"</i>	Reserved (Bit 62) <i>Must be set to "0"</i>	Reserved (Bit 61) <i>Must be set to "0"</i>	Reserved (Bit 60) <i>Must be set to "0"</i>	Reserved (Bit 59) <i>Must be set to "0"</i>	Reserved (Bit 58) <i>Must be set to "0"</i>	Reserved (Bit 57) <i>Must be set to "0"</i>	Reserved (Bit 56) <i>Must be set to "0"</i>
Byte 6	Reserved (Bit 55) <i>Must be set to "0"</i>	Reserved (Bit 54) <i>Must be set to "0"</i>	SHUT2 (Bit 53) 0 = Normal 1 = Powered down	Reserved (Bit 52) <i>Must be set to "0"</i>	Reserved (Bit 51) <i>Must be set to "0"</i>	Reserved (Bit 50) <i>Must be set to "0"</i>	Reserved (Bit 49) <i>Must be set to "0"</i>	Reserved (Bit 48) <i>Must be set to "0"</i>
Byte 5	Reserved (Bit 47) <i>Must be set to "0"</i>	LC (Bit 46) <i>Loop filter cap select</i>	LR[1] (Bit 45) <i>Loop filter resistor select</i>	LR[0] (Bit 44)	Reserved (Bit 43) <i>Must be set to "0"</i>	Reserved (Bit 42) <i>Must be set to "0"</i>	CP[1] (Bit 41) <i>Charge pump current select</i>	CP[0] (Bit 40)
Byte 4	CMOS (Bit 39) 0 = PECL 1 = CMOS	FBKDSRC (Bit 38) 0 = VCO output 1 = Post divider output	FBKDIV[13] (Bit 37) 8192	FBKDIV[12] (Bit 36) 4096	FBKDIV[11] (Bit 35) 2048	FBKDIV[10] (Bit 34) 1024	FBKDIV[9] (Bit 33) 512	FBKDIV[8] (Bit 32) 256
<i>See Section 4.1.2 for disallowed FBKDIV values</i>								
Byte 3	FBKDIV[7] (Bit 31) 128	FBKDIV[6] (Bit 30) 64	FBKDIV[5] (Bit 29) 32	FBKDIV[4] (Bit 28) 16	FBKDIV[3] (Bit 27) 8	FBKDIV[2] (Bit 26) 4	FBKDIV[1] (Bit 25) 2	FBKDIV[0] (Bit 24) 1
<i>See Section 4.1.2 for disallowed FBKDIV values</i>								
Byte 2	POST2[3] (Bit 23) <i>Modulus = N + 1 (N = 0 to 11); See Table 8</i>	POST2[2] (Bit 22)	POST2[1] (Bit 21)	POST2[0] (Bit 20)	POST1[3] (Bit 19)	POST1[2] (Bit 18) <i>Modulus = N + 1 (N = 0 to 11); See Table 8</i>	POST1[1] (Bit 17)	POST1[0] (Bit 16)
Byte 1	POST3[1] (Bit 15) <i>Modulus = 1, 2, 4, or 8; See Table 8</i>	POST3[0] (Bit 14)	SHUT1 (Bit 13) 0 = Normal 1 = Powered down	REFDSRC (Bit 12) 0 = Crystal oscillator 1 = REF pin	REFDIV[11] (Bit 11) 2048	REFDIV[10] (Bit 10) 1024	REFDIV[9] (Bit 9) 512	REFDIV[8] (Bit 8) 256
Byte 0	REFDIV[7] (Bit 7) 128	REFDIV[6] (Bit 6) 64	REFDIV[5] (Bit 5) 32	REFDIV[4] (Bit 4) 16	REFDIV[3] (Bit 3) 8	REFDIV[2] (Bit 2) 4	REFDIV[1] (Bit 1) 2	REFDIV[0] (Bit 0) 1

FS714x

Table 4: FS7145 Register Map

Address	BIT 7	BIT 6	BIT 5	BIT 4	BIT 3	BIT 2	BIT 1	BIT 0
Byte 7	Reserved (Bit 63) <i>Must be set to "0"</i>	Reserved (Bit 62) <i>Must be set to "0"</i>	Reserved (Bit 61) <i>Must be set to "0"</i>	Reserved (Bit 60) <i>Must be set to "0"</i>	Reserved (Bit 59) <i>Must be set to "0"</i>	Reserved (Bit 58) <i>Must be set to "0"</i>	Reserved (Bit 57) <i>Must be set to "0"</i>	Reserved (Bit 56) <i>Must be set to "0"</i>
Byte 6	Reserved (Bit 55) <i>Must be set to "0"</i>	Reserved (Bit 54) <i>Must be set to "0"</i>	SHUT2 (Bit 53) <i>0 = Normal 1 = Powered down</i>	Reserved (Bit 52) <i>Must be set to "0"</i>	Reserved (Bit 51) <i>Must be set to "0"</i>	Reserved (Bit 50) <i>Must be set to "0"</i>	SYNCPOL (Bit 49) <i>"0" = negative "1" = positive</i>	SYNCEN (Bit 48) <i>"0" = negative "1" = positive</i>
Byte 5	Reserved (Bit 47) <i>Must be set to "0"</i>	LC (Bit 46) <i>Loop filter cap select</i>	LR[1] (Bit 45) <i>Loop filter resistor select</i>	LR[0] (Bit 44) <i>Loop filter resistor select</i>	Reserved (Bit 43) <i>Must be set to "0"</i>	Reserved (Bit 42) <i>Must be set to "0"</i>	CP[1] (Bit 41) <i>Charge pump current select</i>	CP[0] (Bit 40) <i>Charge pump current select</i>
Byte 4	CMOS (Bit 39) <i>0 = PECL 1 = CMOS</i>	FBKDSRC (Bit 38) <i>0 = VCO output 1 = Post divider output</i>	FBKDIV[13] (Bit 37) <i>8192</i>	FBKDIV[12] (Bit 36) <i>4096</i>	FBKDIV[11] (Bit 35) <i>2048</i>	FBKDIV[10] (Bit 34) <i>1024</i>	FBKDIV[9] (Bit 33) <i>512</i>	FBKDIV[8] (Bit 32) <i>256</i>
<i>See Section 4.1.2 for disallowed FBKDIV values</i>								
Byte 3	FBKDIV[7] (Bit 31) <i>128</i>	FBKDIV[6] (Bit 30) <i>64</i>	FBKDIV[5] (Bit 29) <i>32</i>	FBKDIV[4] (Bit 28) <i>16</i>	FBKDIV[3] (Bit 27) <i>8</i>	FBKDIV[2] (Bit 26) <i>4</i>	FBKDIV[1] (Bit 25) <i>2</i>	FBKDIV[0] (Bit 24) <i>1</i>
<i>See Section 4.1.2 for disallowed FBKDIV values</i>								
Byte 2	POST2[3] (Bit 23) <i>Modulus = N + 1 (N = 0 to 11); See Table 8</i>	POST2[2] (Bit 22) <i>Modulus = N + 1 (N = 0 to 11); See Table 8</i>	POST2[1] (Bit 21) <i>Modulus = N + 1 (N = 0 to 11); See Table 8</i>	POST2[0] (Bit 20) <i>Modulus = N + 1 (N = 0 to 11); See Table 8</i>	POST1[3] (Bit 19) <i>Modulus = N + 1 (N = 0 to 11); See Table 8</i>	POST1[2] (Bit 18) <i>Modulus = N + 1 (N = 0 to 11); See Table 8</i>	POST1[1] (Bit 17) <i>Modulus = N + 1 (N = 0 to 11); See Table 8</i>	POST1[0] (Bit 16) <i>Modulus = N + 1 (N = 0 to 11); See Table 8</i>
Byte 1	POST3[1] (Bit 15) <i>Modulus = 1, 2, 4, or 8; See Table 8</i>	POST3[0] (Bit 14) <i>Modulus = 1, 2, 4, or 8; See Table 8</i>	SHUT1 (Bit 13) <i>0 = Normal 1 = Powered down</i>	REFDSRC (Bit 12) <i>0 = Crystal oscillator 1 = REF pin</i>	REFDIV[11] (Bit 11) <i>2048</i>	REFDIV[10] (Bit 10) <i>1024</i>	REFDIV[9] (Bit 9) <i>512</i>	REFDIV[8] (Bit 8) <i>256</i>
Byte 0	REFDIV[7] (Bit 7) <i>128</i>	REFDIV[6] (Bit 6) <i>64</i>	REFDIV[5] (Bit 5) <i>32</i>	REFDIV[4] (Bit 4) <i>16</i>	REFDIV[3] (Bit 3) <i>8</i>	REFDIV[2] (Bit 2) <i>4</i>	REFDIV[1] (Bit 1) <i>2</i>	REFDIV[0] (Bit 0) <i>1</i>

Table 5: Device Configuration Bits

Name	Description
REFDSRC	Reference divider source [0] = crystal oscillator / [1] = REF pin
FBKDSRC	Feedback divider source [0] = VCO output / [1] = post divider output
SHUT1	Shutdown1 [0] = normal / [1] = powered down
SHUT2	Shutdown2 [0] = normal / [1] = powered down
CMOS	CLKP/CLKN output mode [0] = PECL output / [1] CMOS output

Table 6: Main Loop Tuning Bits

Name	Description
CP[1:0]	Charge pump current [00] 2.0µA [01] 4.5µA [10] 11.0µA [11] 22.5µA
LR[1:0]	Loop filter resistor select [00] 400KΩ [01] 133KΩ [10] 30KΩ [11] 12KΩ
LC	Loop filter capacitor select [0] 185pF [1] 500pF

Table 7: PLL Divider Control Bits

Name	Description
REFDIV[11:0]	Reference divider (N _R)
FBKDIV[13:0]	Feedback divider (N _R)

FS714x

Table 8: SYNC Control Bits (FS7145 only)

Name	Description
SYNCEN	Sync enable [0] = disabled / [1] = enabled
SYNCPOL	Sync polarity [0] = negative edge / [1] = positive edge

Table 9: Post Divider Control Bits

Name	Description
	Post divider #1 (N_{P1}) modulus
	[0000] 1
	[0001] 2
	[0010] 3
	[0011] 4
	[0100] 5
	[0101] 6
	[0110] 7
POST1[3:0]	[0111] 8
	[1000] 9
	[1001] 10
	[1010] 11
	[1011] 12
	[1100] Do not use
	[1101] Do not use
	[1110] Do not use
	[1111] Do not use
	Post divider #2 (N_{P2}) modulus
	[0000] 1
	[0001] 2
	[0010] 3
	[0011] 4
	[0100] 5
	[0101] 6
	[0110] 7
POST2[3:0]	[0111] 8
	[1000] 9
	[1001] 10
	[1010] 11
	[1011] 12
	[1100] Do not use
	[1101] Do not use
	[1110] Do not use
	[1111] Do not use
	Post divider #3 (N_{P3}) modulus
POST3[1:0]	[00] 1
	[01] 2
	[10] 4
	[11] 8

FS714x

7.0 Electrical Specifications

Table 10: Absolute Maximum Ratings

Parameter	Symbol	Min.	Max.	Units
Supply voltage, dc ($V_{SS} = \text{ground}$)	V_{DD}	$V_{SS} - 0.5$	4.5	V
Input voltage, dc	V_I	$V_{SS} - 0.5$	$V_{DD} + 0.5$	V
Output voltage, dc	V_O	$V_{SS} - 0.5$	$V_{DD} + 0.5$	V
Input clamp current, dc ($V_I < 0$ or $V_I > V_{DD}$)	I_{IK}	-50	50	mA
Output clamp current, dc ($V_I < 0$ or $V_I > V_{DD}$)	I_{OK}	-50	50	mA
Storage temperature range (non-condensing)	T_S	-65	150	°C
Ambient temperature range, under bias	T_A	-55	125	°C
Junction temperature	T_J		150	°C
Re-flow solder profile				Per IPC/JEDEC J-STD-020B
Input static discharge voltage protection (MIL-STD 883E, Method 3015.7)			2	kV

Stresses above those listed under Absolute Maximum Ratings may cause permanent damage to the device. These conditions represent a stress rating only and functional operation of the device at these or any other conditions above the operational limited noted in this specification is not implied. Exposure to maximum rating conditions for extended conditions may affect device performance, functionality and reliability.



CAUTION: ELECTROSTATIC SENSITIVE DEVICE

Permanent damage resulting in a loss of functionality or performance may occur if this device is subjected to a high-energy electrostatic discharge.

Table 11: Operating Conditions

Parameter	Symbol	Conditions/Description	Min.	Typ.	Max.	Units
Supply voltage	V_{DD}		3.0	3.3	3.6	V
Ambient operating temperature range	T_A		0		70	°C

FS714x

Table 12: DC Electrical Specifications

Parameter	Symbol	Conditions/Description	Min.	Typ.	Max.	Units
Overall						
Supply current, dynamic	I_{DD}	CMOS mode; $F_{XTAL} = 15\text{MHz}$; $F_{VCO} = 400\text{MHz}$; $F_{CLK} = 200\text{MHz}$; does not include load current		35		mA
Supply current, static	I_{DDL}	SHUT1, SHUT2 bit both "1"		400	700	μA
Serial Communication I/O (SDA, SCL)						
High-level input voltage	V_{IH}		$0.8 \cdot V_{DD}$			V
Low-level input voltage	V_{IL}				$0.2 \cdot V_{DD}$	V
Hysteresis voltage	V_{HYS}			$0.33 \cdot V_{DD}$		V
Input leakage current	I_I	SDA, SCL in read condition	-10		+10	μA
Low-level output sink current (SDA)	I_{OL}	SDA in acknowledge condition; $V_{SDA} = 0.4\text{V}$	5	14		mA
Address Select Input (ADDR0, ADDR1)						
High-level input voltage	V_{IH}		$V_{DD} - 1.0$			V
Low-level input voltage	V_{IL}				0.8	V
High-level input current (pull-down)	I_{IH}	$V_{ADDRx} = V_{DD}$		30		μA
Low-level input current	I_{IL}	$V_{ADDRx} = 0\text{V}$	-1		1	μA
Reference Frequency Input (REF)						
High-level input voltage	V_{IH}		$V_{DD} - 1.0$			V
Low-level input voltage	V_{IL}				0.8	V
High-level input current	I_{IH}	$V_{REF} = V_{DD}$	-1		1	μA
Low-level input current (pull-down)	I_{IL}	$V_{REF} = 0\text{V}$		-30		μA
Sync Control Input (SYNC)						
High-level input voltage	V_{IH}		$V_{DD} - 1.0$			V
Low-level input voltage	V_{IL}				0.8	V
High-level input current	I_{IH}	$V_{REF} = V_{DD}$	-1		1	μA
Low-level input current (pull-down)	I_{IL}	$V_{REF} = 0\text{V}$		-30		μA
Crystal Oscillator Input (XIN)						
Threshold bias voltage	V_{TH}			$V_{DD}/2$		V
High-level input current	I_{IH}	$V_{XIN} = V_{DD}$		40		μA
Low-level input current	I_{IL}	$V_{XIN} = \text{GND}$		-40		μA
Crystal frequency	F_X	Fundamental mode			35	MHz
Recommended crystal load capacitance*	$C_{L(XTAL)}$	For best matching with internal crystal oscillator load		16-18		pF
Crystal Oscillator Output (XOUT)						
High-level output source current	I_{OH}	$V_{XOUT} = 0$		-8.5		mA
Low-level output sink current	I_{OL}	$V_{XOUT} = V_{DD}$		11		mA
PECL Current Program I/O (IPRG)						
Low-level input current	I_{IL}	$V_{IPRG} = 0\text{V}$; PECL mode	-10		10	μA
Clock Outputs, CMOS Mode (CLKN, CLKP)						
High-level output source current	I_{OH}	$V_O = 2.0\text{V}$		19		mA
Low-level output sink current	I_{OL}	$V_O = 0.4\text{V}$		-35		mA
Clock Outputs, PECL Mode (CLKN, CLKP)						
IPRG bias voltage	V_{IPRG}	V_{IPRG} will be clamped to this level when a resistor is connected from VDD to IPRG		$V_{DD}/3$		V
IPRG bias current	I_{IPRG}	$I_{IPRG} - (V_{VDD} - V_{IPRG}) / R_{SET}$			3.5	mA
Sink current to IPRG current ratio				13		
Tristate output current	I_Z		-10		10	μA

Unless otherwise stated, $V_{DD} = 3.3\text{V} \pm 10\%$, no load on any output, and ambient temperature range $T_A = 0^\circ\text{C}$ to 70°C . Parameters denoted with an asterisk (*) represent nominal characterization data and are not production tested to any specific limits. MIN and MAX characterization data are $\pm 3\sigma$ from typical. Negative currents indicate flows out of the device.

FS714x

Table 13: AC Timing Specifications

Parameter	Symbol	Conditions/Description	Clock (MHz)	Min.	Typ.	Max.	Units	
Overall								
Output frequency*	$f_{o(max)}$	CMOS outputs PECL outputs		0 0		150 300	MHz	
VCO frequency*	f_{VCO}			40		400	MHz	
CMOS mode rise time*	t_r	$C_L = 7pF$			1		ns	
CMOS mode fall time*	t_f	$C_L = 7pF$			1		ns	
PECL mode rise time*	t_r	$C_L = 7pF; R_L = 65\text{ ohm}$			1		ns	
PECL mode fall time*	t_f	$C_L = 7pF; R_L = 65\text{ ohm}$			1		ns	
Reference Frequency Input (REF)								
Input frequency	F_{REF}					80	MHz	
Reference high time	t_{REHF}			3			ns	
Reference low time	t_{REFL}			3			ns	
Sync Control Input (SYNC)								
Sync high time	t_{SYNCH}	For orderly CLK stop/start		3			T_{CLK}	
Sync low time	t_{SYNCL}	For orderly CLK stop/start		3			T_{CLK}	
Clock Output (CLKP, CLKN)								
Duty cycle (CMOS mode)*		Measured at 1.4V			50		%	
Duty cycle (PECL mode)*		Measured at zero crossings of ($V_{CLKP} - V_{CLKN}$)			50		%	
Jitter, long term ($\sigma_y(\tau)$)*	$t_{j(LT)}$	For valid programming solutions. Long-term (or cumulative) jitter specified is RMS position error of any edge compared with an ideal clock generated from the same reference frequency. It is measured with a time interval analyzer using a 500 microsecond window, using statistics gathered over 1000 samples.						ps
		FREF/NREF > 1000kHz					25	ps
		FREF/NREF \approx 500kHz					50	ps
		FREF/NREF \approx 250kHz					100	ps
		FREF/NREF \approx 125kHz					190	ps
		FREF/NREF \approx 62.5kHz					240	ps
Jitter, period (peak-peak)*	$t_{j(AP)}$	40MHz < VCO frequency < 100MHz					75	ps
		VCO frequency > 100MHz					50	ps

Unless otherwise stated, $V_{DD} = 3.3V \pm 10\%$, no load on any output, and ambient temperature range $T_A = 0^\circ C$ to $70^\circ C$. Parameters denoted with an asterisk (*) represent nominal characterization data and are not production tested to any specific limits. MIN and MAX characterization data are $\pm 3\sigma$ from typical.

Table 14: Serial Interface Timing Specifications

Parameter	Symbol	Conditions/Description	Fast Mode		Units
			Min.	Max.	
Clock frequency	f_{SCL}	SCL	0	400	kHz
Bus free time between STOP and START	t_{BUF}		1300		ns
Set-up time, START (repeated)	$T_{su:STA}$		600		ns
Hold time, START	$t_{hd:STA}$		600		ns
Set-up time, data input	$T_{su:DAT}$	SDA	100		ns
Hold time, data input	$t_{hd:DAT}$	SDA	0		ns
Output data valid from clock	t_{AA}			900	ns
Rise time, data and clock	t_R	SDA, SCL		300	ns
Fall time, data and clock	t_F	SDA, SCL		300	ns
High time, clock	t_{HI}	SCL	600		ns
Low time, clock	t_{LO}	SCL	1300		ns
Set-up time, STOP	$T_{su:STO}$		600		ns

Unless otherwise stated, $V_{DD} = 3.3V \pm 10\%$, no load on any output, and ambient temperature range $T_A = 0^\circ C$ to $70^\circ C$. Parameters denoted with an asterisk (*) represent nominal characterization data and are not production tested to any specific limits. MIN and MAX characterization data are $\pm 3\sigma$ from typical.

FS714x

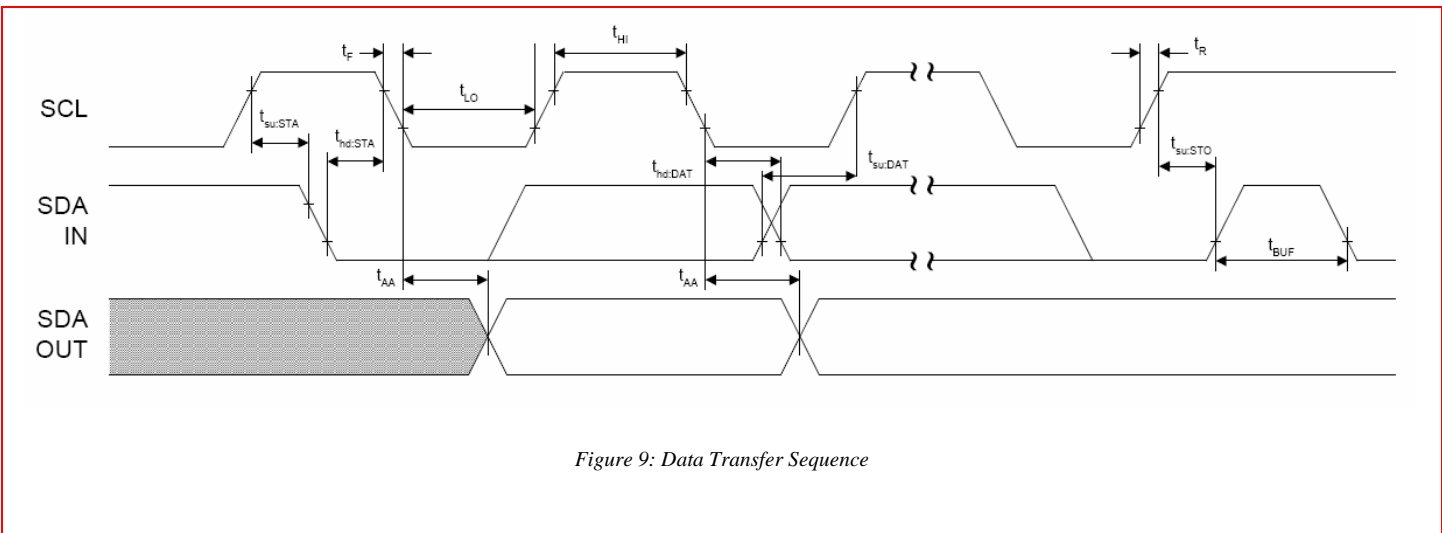
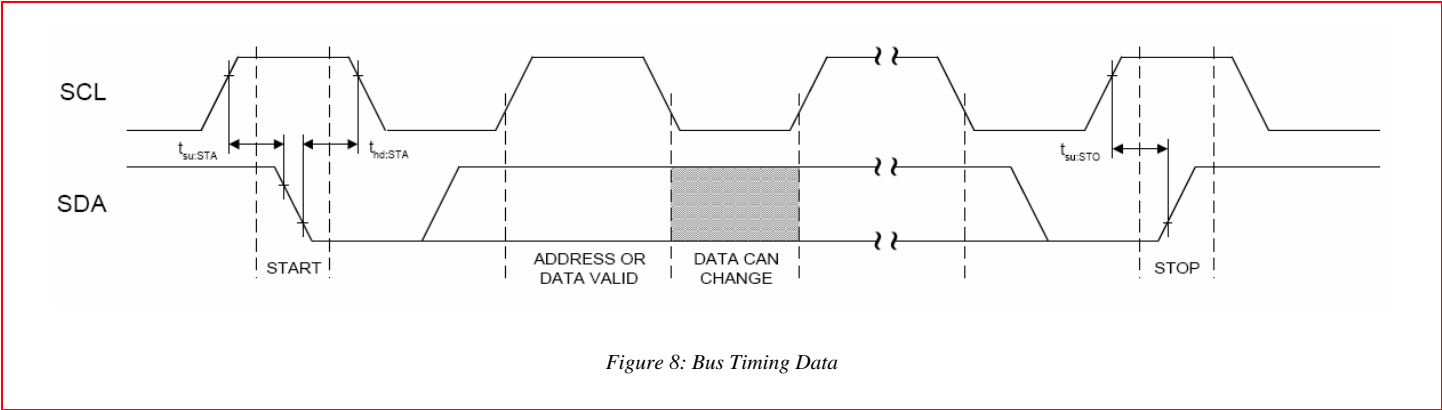

FS714x

8.0 Package Information for ‘Green’ and ‘Non-Green’

Table 15: 16-pin SOIC (0.150") Package Dimensions

	Dimensions			
	Inches		Millimeters	
	Min.	Max.	Min.	Max.
A	0.061	0.068	1.55	1.73
A1	0.004	0.0098	0.102	0.249
A2	0.055	0.061	1.40	1.55
B	0.013	0.019	0.33	0.49
C	0.0075	0.0098	0.191	0.249
D	0.386	0.393	9.80	9.98
E	0.150	0.157	3.81	3.99
e	0.050 BSC		1.27 BSC	
H	0.230	0.244	5.84	6.20
h	0.010	0.016	0.25	0.41
L	0.016	0.035	0.41	0.89
⊖	0°	8°	0°	8°

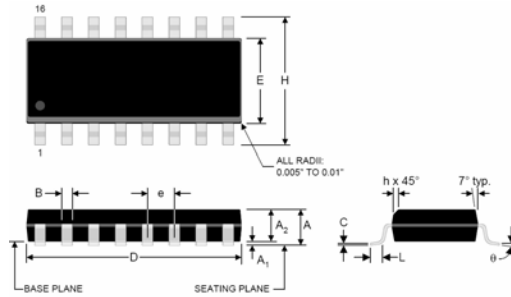

Table 16: 16-pin SOIC (0.150") Package Characteristics

Parameter	Symbol	Conditions/Description	Typ.	Units
Thermal impedance, junction to free-air	Θ_{JA}	Air flow = 0ft./min.	108	°C/W
Lead inductance, self	L_{11}	Corner lead	2.5	nH
		Center lead	1.2	nH

Table 17: 16-pin 5.3mm (0.209") SSOP Package Dimensions

	Dimensions			
	Inches		Millimeters	
	Min.	Max.	Min.	Max.
A	0.068	0.078	1.73	1.99
A1	0.002	0.008	0.05	0.21
A2	0.066	0.070	1.68	1.78
B	0.010	0.015	0.25	0.38
C	0.005	0.008	0.13	0.20
D	0.239	0.249	6.07	6.33
E	0.205	0.212	5.20	5.38
e	0.0256 BSC		0.65 BSC	
H	0.301	0.311	7.65	7.90
L	0.022	0.037	0.55	0.95
⊖	0	8	0	8

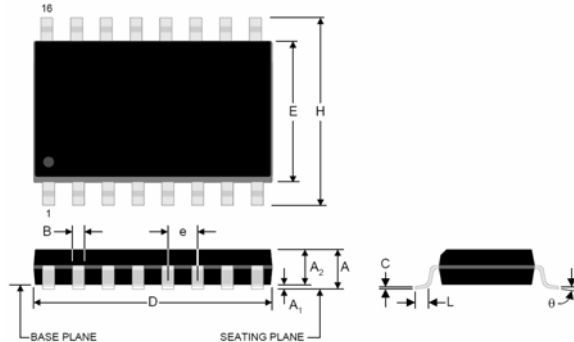

Table 18: 16-pin 5.3mm (0.208") SSOP Package Characteristics

Parameter	Symbol	Conditions/Description	Typ.	Units
Thermal impedance, junction to free-air	Θ_{JA}	Air flows = 0ft./min	90	°C/W
Lead inductance, self	L_{11}	Corner lead	2.3	nH
		Center lead	1	nH

FS714x

9.0 Ordering Information

Part Number	Package	Shipping Configuration	Temperature Range
FS7145-01-XTD	16-pin (0.150") SOIC	Tube/Tray	0°C to 70°C (commercial)
FS7145-01-XTP	16-pin (0.150") SOIC	Tape & Reel	0°C to 70°C (commercial)
FS7140-02G-XTD	16-pin (5.3mm) SSOP 'Green' or lead-free packaging	Tube/Tray	0°C to 70°C (commercial)
FS7140-02G-XTP	16-pin (5.3mm) SSOP 'Green' or lead-free packaging	Tape & Reel	0°C to 70°C (commercial)
FS7140-01G-XTD	16-pin (0.150") SOIC 'Green' or lead-free packaging	Tube/Tray	0°C to 70°C (commercial)
FS7140-01G-XTP	16-pin (0.150") SOIC 'Green' or lead-free packaging	Tape & Reel	0°C to 70°C (commercial)

10.0 Revision History

Revision	Date	Modification
3	February 2006	
4	December 2007	Update to new AMIS template; update ordering codes
5	May 2008	Update to new ON Semiconductor template

ON Semiconductor and  are registered trademarks of Semiconductor Components Industries, LLC (SCILLC). SCILLC reserves the right to make changes without further notice to any products herein. SCILLC makes no warranty, representation or guarantee regarding the suitability of its products for any particular purpose, nor does SCILLC assume any liability arising out of the application or use of any product or circuit, and specifically disclaims any and all liability, including without limitation special, consequential or incidental damages. "Typical" parameters which may be provided in SCILLC data sheets and/or specifications can and do vary in different applications and actual performance may vary over time. All operating parameters, including "Typicals" must be validated for each customer application by customer's technical experts. SCILLC does not convey any license under its patent rights nor the rights of others. SCILLC products are not designed, intended, or authorized for use as components in systems intended for surgical implant into the body, or other applications intended to support or sustain life, or for any other application in which the failure of the SCILLC product could create a situation where personal injury or death may occur. Should Buyer purchase or use SCILLC products for any such unintended or unauthorized application, Buyer shall indemnify and hold SCILLC and its officers, employees, subsidiaries, affiliates, and distributors harmless against all claims, costs, damages, and expenses, and reasonable attorney fees arising out of, directly or indirectly, any claim of personal injury or death associated with such unintended or unauthorized use, even if such claim alleges that SCILLC was negligent regarding the design or manufacture of the part. SCILLC is an Equal Opportunity/Affirmative Action Employer. This literature is subject to all applicable copyright laws and is not for resale in any manner.

PUBLICATION ORDERING INFORMATION

LITERATURE FULFILLMENT:

Literature Distribution Center for ON Semiconductor
P.O. Box 5163, Denver, Colorado 80217 USA
Phone: 303-675-2175 or 800-344-3860 Toll Free USA/Canada
Fax: 303-675-2176 or 800-344-3867 Toll Free USA/Canada
Email: orderlit@onsemi.com

N. American Technical Support: 800-282-9855
Toll Free USA/Canada
Europe, Middle East and Africa Technical Support:
Phone: 421 33 790 2910
Japan Customer Focus Center
Phone: 81-3-5773-3850

ON Semiconductor Website: www.onsemi.com

Order Literature: <http://www.onsemi.com/orderlit>

For additional information, please contact your local Sales Representative