

Description

The EV1320QI is a DC to DC converter specifically designed for memory termination applications. The device offers high efficiency, up to 96%, while providing a solution footprint similar to that of a linear termination device.

The EV1320QI comes in a 3mm x 3mm x 0.55mm QFN 16-pin package and requires only a small number of external MLCC capacitors. The device is designed to operate directly from the VDDQ supply rail. No external divider or reference is required. The EV1320QI provides a very stable output voltage (VTT) which tracks VDDQ while sinking and sourcing up to 2A of continuous output current. Up to 4 EV1320QI devices can be paralleled to source up to 8A of current. An ENABLE pin with output discharge is available for S3 (suspend to RAM) states.

EV1320QI is specifically designed to meet the precise voltage, fast transient requirements of present and future high-performance, DDR2, DDR3, and low power DDR4 JEDEC VTT requirements. Advanced circuit techniques and high switching frequency deliver high-quality, compact, non-isolated DC-DC conversion.

Features

- High Efficiency, Up to 96%
- 40mm² Total Solution Size
- No External Inductor Required
- JEDEC Compliant DDR2/3/QDR and Low Power DDR 4 Solution
- Enable Pin with Output Discharge to Support S3 (Suspend to RAM) Mode
- Operates Directly from VDDQ
- VOUT (VTT) Voltage Tracks VDDQ/2 ± 40mV
- Source and Sink Up to 2A Continuous Current
- Parallel Up to 4 Devices for 8A VTT Current
- Programmable Soft Start/Soft Shutdown
- Cost Effective Integrated Solution
- Thermal Overload, Over Current, Short Circuit, and Under-Voltage Protection
- RoHS Compliant, MSL level 3, 260C Reflow

Applications

- VTT Bus Termination for DDR2, DDR3, Low Power DDR4, and QDR Memories

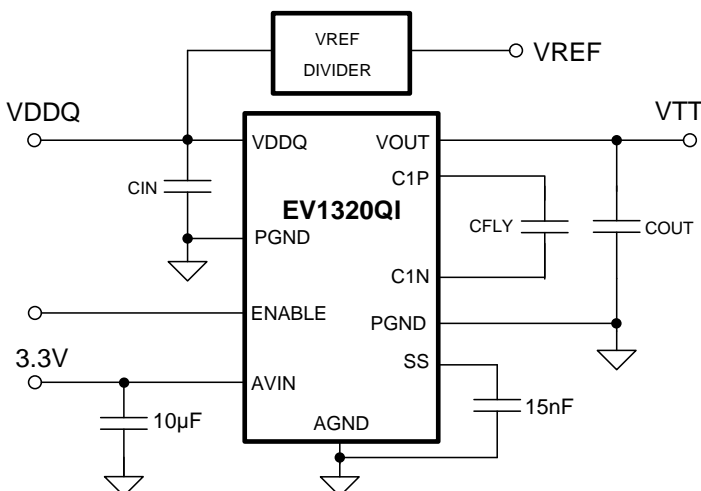

Figure 1. Simplified Applications Circuit

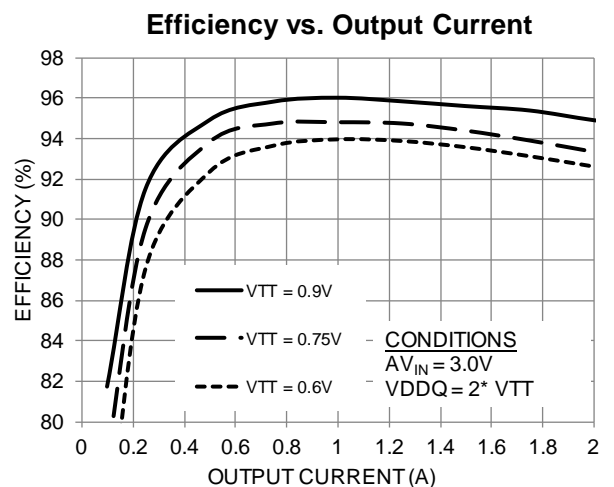

Figure 2. Highest Efficiency in Smallest Solution Size

Ordering Information

Part Number	Package Markings	Temp Rating (°C)	Package Description
EV1320QI	AUxx	-40 to +85	16-pin (3mm x 3mm x 0.55mm) QFN T&R
EVB-EV1320QI	AUxx		QFN Evaluation Board

Pin Assignments (Top View)

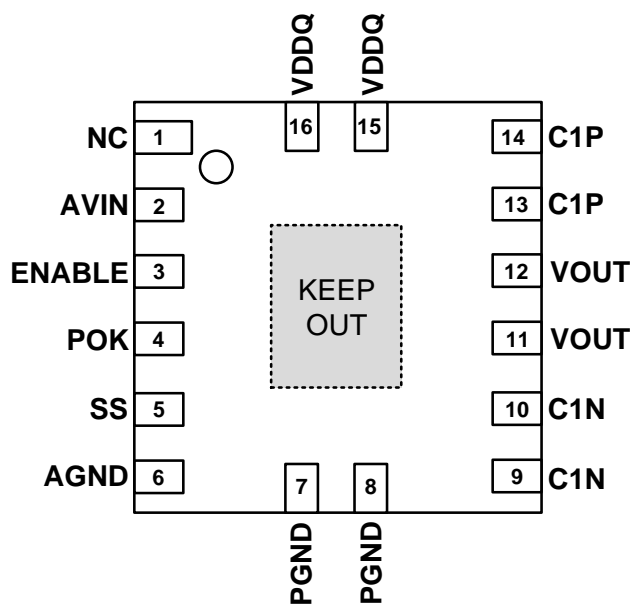

Figure 3: Pin Out Diagram (Top View)

NOTE A: Shaded area highlights exposed metal below the package that is not to be mechanically or electrically connected to the PCB. Refer to Figure 10 for details.

NOTE B: White 'dot' on top left is pin 1 indicator on top of the device package.

Pin Description

PIN	NAME	FUNCTION
1	NC	This pin is internally not connected. May be used as part of the VDDQ copper to optimize the layout. Otherwise, leave this pin open. See Figure 9.
2	AVIN	Input Supply for internal controller and protection circuitry
3	ENABLE	Input Enable. Applying a logic high enables the output and initiates a soft-start. Applying a logic low disables and discharges the output. ENABLE is internally tied to AVIN and ground through a 100k resistor divider. Leaving ENABLE floating will result in voltage at half of AVIN.
4	POK	VTT OK flag. This is an open drain output usually pulled up to AVIN. Leave floating if unused.
5	SS	Soft Start pin. Connect soft start capacitor between this pin and AGND.
6	AGND	Quiet ground for analog circuitry. Connect to the ground plane with a via next to the pin.
7, 8	PGND	Power ground. Connect these pins to the ground electrode of the input and output filter capacitors. See layout recommendations for more details.
9,10	C1N	Place 1 x 22µF and 1 x 10µF X5R MLCC capacitors between C1N and C1P.
11,12	VOUT	VTT voltage = ½ VDDQ.
13,14	C1P	Place 1 x 22µF and 1 x 10µF X5R MLCC capacitors between C1N and C1P.
15,16	VDDQ	VDDQ voltage; VOUT (VTT) tracks this voltage.

Absolute Maximum Ratings

CAUTION: Absolute Maximum ratings are stress ratings only. Functional operation beyond the recommended operating conditions is not implied. Stress beyond the absolute maximum ratings may impair device life. Exposure to absolute maximum rated conditions for extended periods may affect device reliability.

PARAMETER	SYMBOL	MIN	MAX	UNITS
Voltage on AVIN		-0.5	4.0	V
Voltage on C1P, C1N		-0.5	2.0	V
Voltage on AGND, PGND		-0.5	AVIN + 0.3	V
Voltage on VDDQ		-0.5	2.2	V
Voltage on VOUT		-0.5	VDDQ + 0.3	V
Voltage on POK		-0.5	AVIN + 0.3	V
Voltage on SS		-0.5	AVIN + 0.3	V
Voltage on ENABLE		-0.5	AVIN + 0.3	V
Storage Temperature Range	TSTG	-65	150	°C
Maximum Operating Junction Temperature	TJ-ABS Max		150	°C
Reflow Temp, 10 Sec, MSL3 JEDEC J-STD-020A			260	°C
ESD Rating (based on Human Body Model): All pins		2000		V
ESD Rating (based on Charged Device Model)		500		V

Recommended Operating Conditions

PARAMETER	SYMBOL	MIN	MAX	UNITS
Operating Junction Temperature	T _J	-40	+125	°C
Operating Ambient Temperature	T _A	-40	+85	°C

Thermal Characteristics

PARAMETER	SYMBOL	TYP	UNITS
Thermal Resistance: Junction to Ambient (0 LFM) (Note 1)	θ_{JA}	50	°C/W
Thermal Shutdown	T _{SD}	150	°C
Thermal Shutdown Hysteresis	T _{SDH}	25	°C

Note 1: Based on 2oz. external copper layers and proper thermal design in line with EIJ/JEDEC JESD51-7 standard for high thermal conductivity boards.

Electrical Characteristics

NOTE: AVIN = 3.3V; VDDQ = 1.5V. Minimum and Maximum values are over operating ambient temperature range unless otherwise noted. Typical values are at T_A = 25°C.

PARAMETER	SYMBOL	TEST CONDITIONS	MIN	TYP	MAX	UNITS
VDDQ voltage range	VDDQ		0.95	1.5	1.8	V
AVIN voltage range	AVIN		3.0	3.3	3.465	V
VTT Tracking Accuracy DC (NOTE 2)	ΔV_{TT}	AVIN=3.3V±5% 0A ≤ I _{VTT} ≤ 2A	0.49* VDDQ - 40		0.51* VDDQ + 40	mV
Under Voltage Lockout; AVIN rising	V _{UVLO}			2.5		V
Under Voltage Lockout; AVIN falling	V _{UVLO}			2.2		V
AVIN Shut-Down Supply Current	I _S	ENABLE=Low			600	μA
VDDQ Shut-Down Supply Current	I _S	ENABLE=Low			200	μA
AVIN No Load Operating Current	I _{AVIN}	AVIN=3.3V		6		mA
VDDQ No Load Operating Current	I _{VDDQ}	AVIN=3.3V		750		μA
Switching Frequency	F _{SW}		500	625	750	kHz
POK Threshold Sourcing Current		V _{OUT} Rising		95		%
POK Threshold Sourcing Current		V _{OUT} Falling		85		%
POK Low Voltage		I _{SINK} = 1mA		0.15	0.4	V
POK Pin V _{OH} Leakage Current		AVIN = 3.3V POK High			25	μA
Output Impedance	R _{OUT}	$\Delta V_{OUT}/\Delta I_{LOAD}$		20		mΩ
Continuous Output Current;	I _{Max_Source}	VDDQ=1.5V AVIN=3.3V	-2		2	A
Over Current Trip Level	I _{OCP}	AVIN=3.3V		±4.5		A
Enable Threshold Logic Low	ENA_VIL	Max voltage to ensure the converter is disabled			0.3	V
Enable Threshold Logic High	ENA_VIH	3.0V ≤ AVIN ≤ 3.46V	AVIN - 0.5		AVIN	V
Enable Input Current				100	200	μA

Note 2: As measured at the bulk capacitors at the edge of EV1320QI evaluation board. Complies with JEDEC DDR2 and DDR3 VDDQ tracking specification.

Typical Performance Curves

Efficiency vs. Output Current

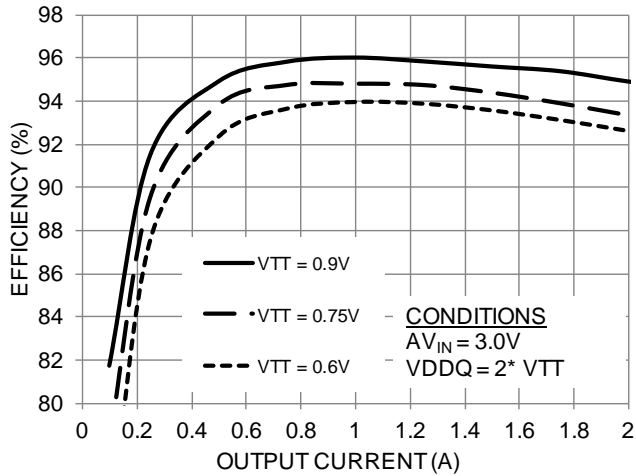

Efficiency vs. Output Current

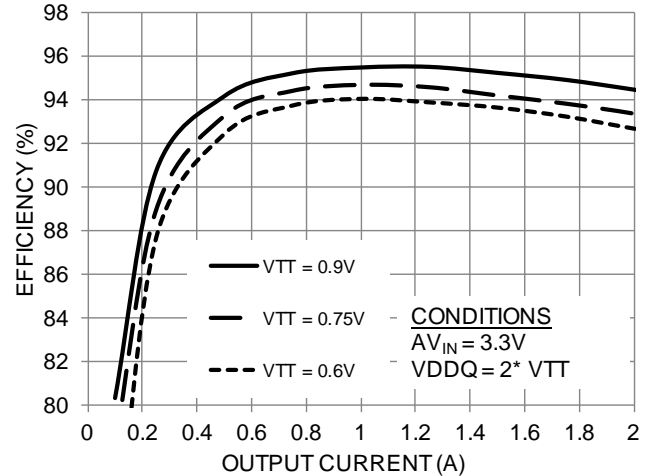

Efficiency vs. Output Current

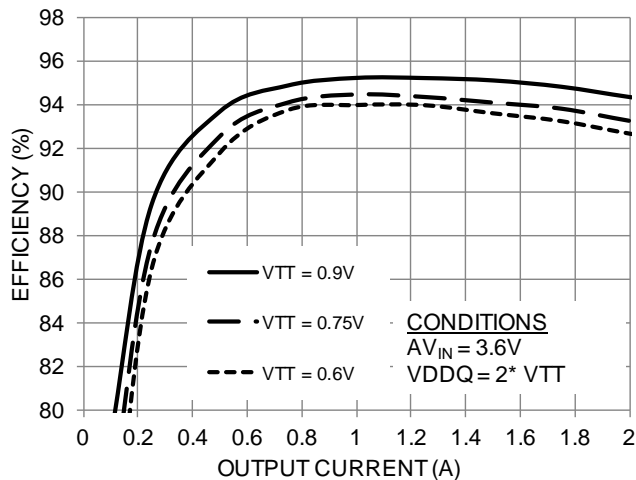

Output Voltage vs. Input Voltage

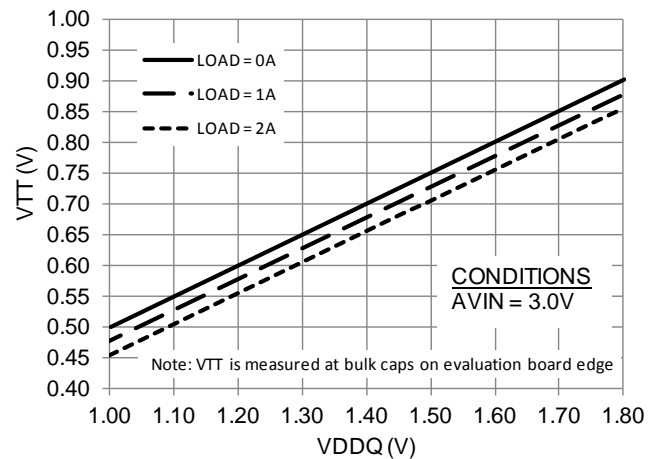

Output Voltage vs. Input Voltage

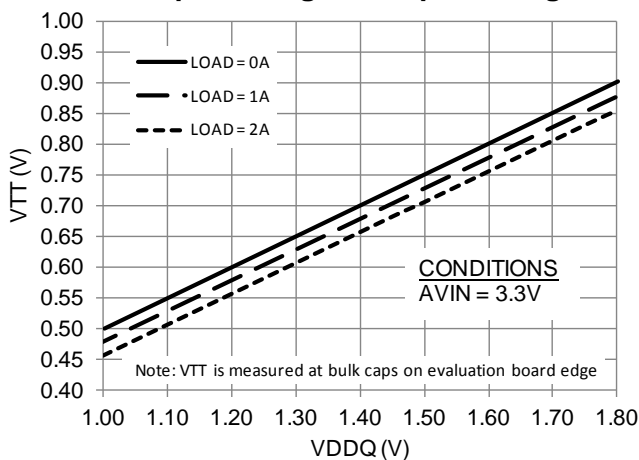

Output Voltage vs. Input Voltage

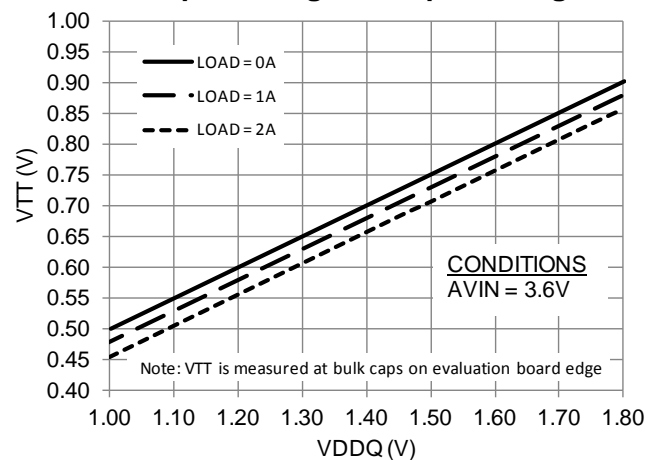

Typical Performance Curves (Continued)

Output Voltage vs. Output Current

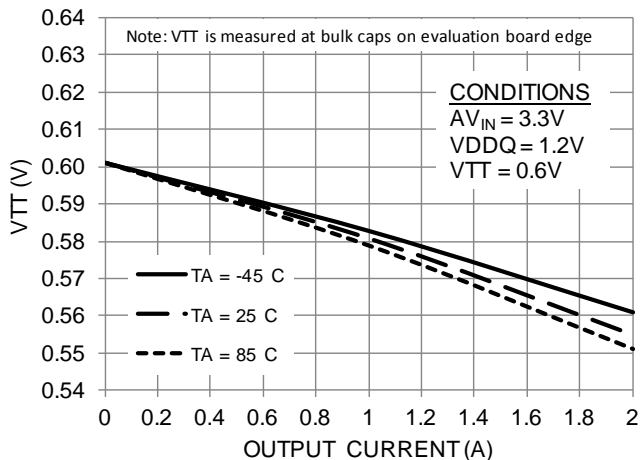

Output Voltage vs. Output Current

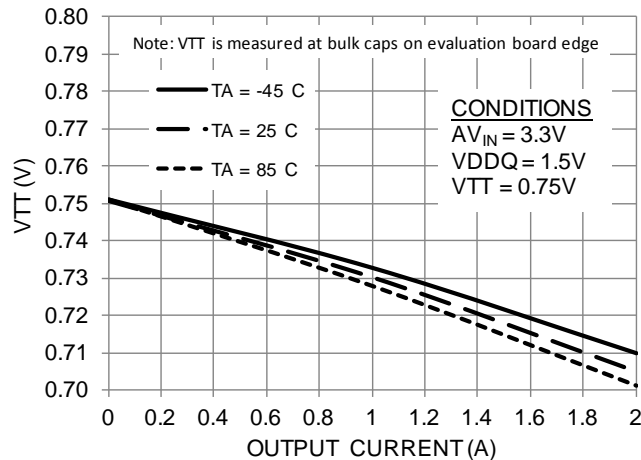

Output Voltage vs. Output Current

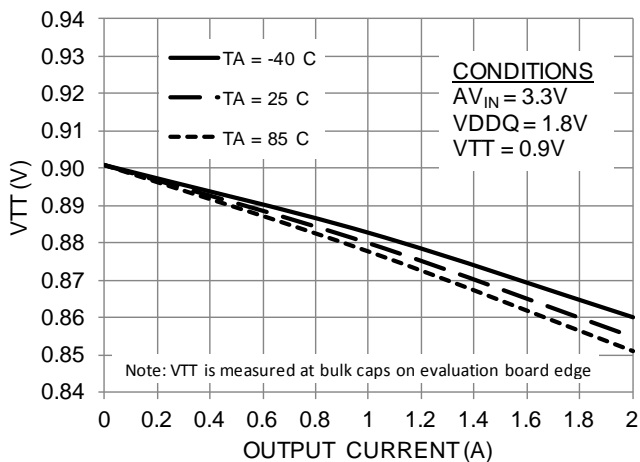

Output Voltage vs. Temperature

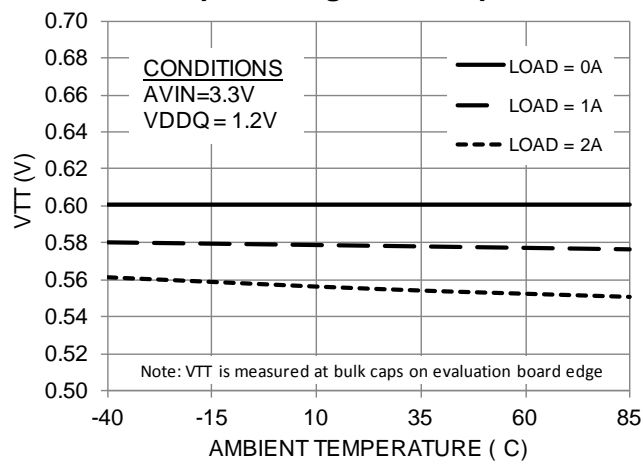

Output Voltage vs. Temperature

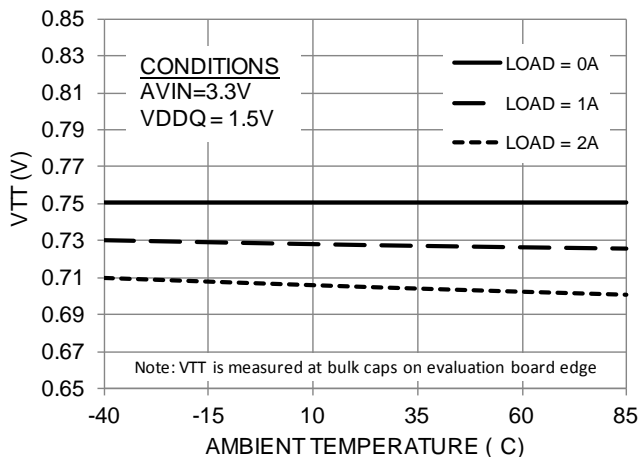

Output Voltage vs. Temperature

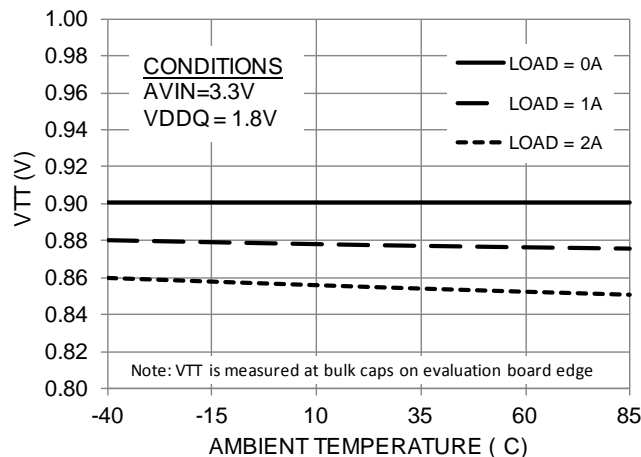

Typical Performance Curves (Continued)

AVIN Input Current vs. Temperature

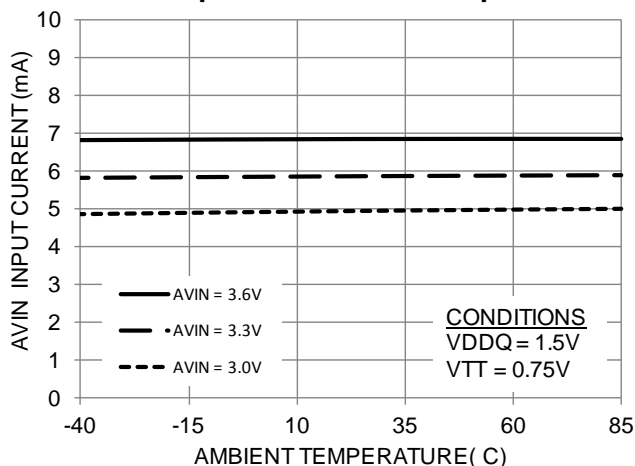

AVIN Input Current vs. Temperature

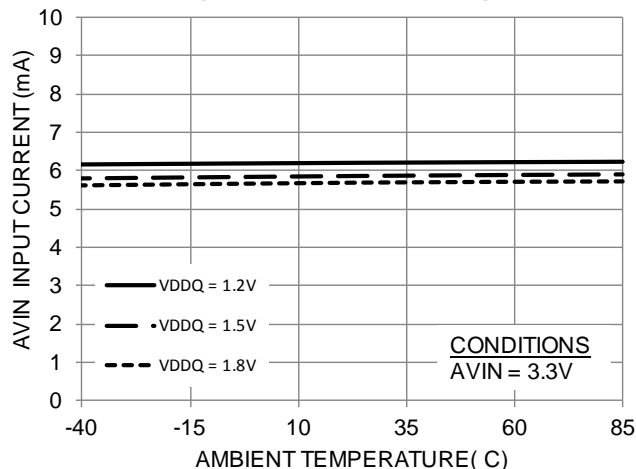

VDDQ Input Current vs. Temperature

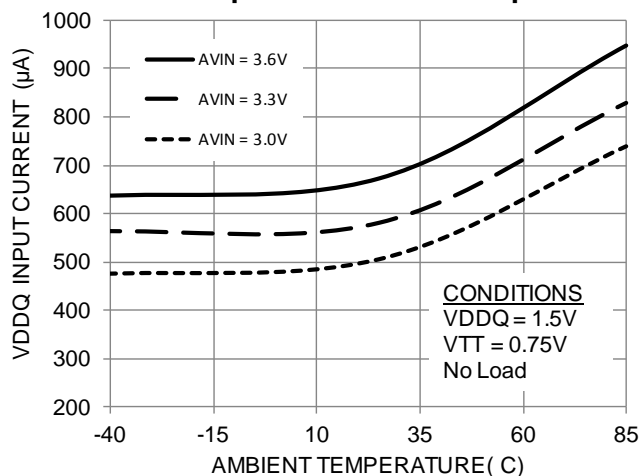

VDDQ Input Current vs. Temperature

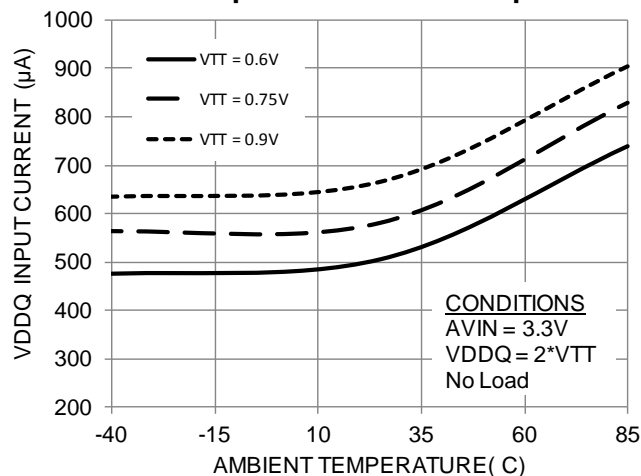

Frequency vs. Temperature

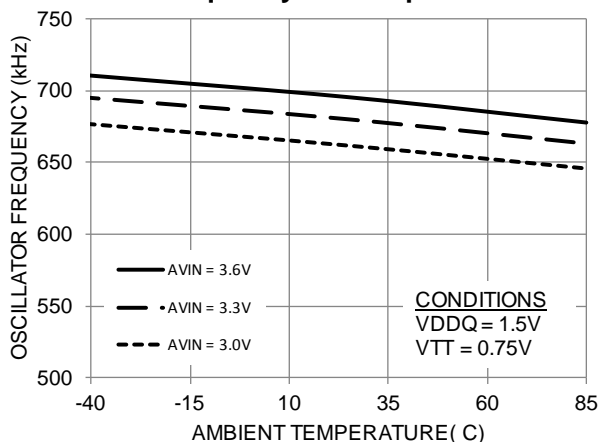

VTT Rise Time vs. Capacitance

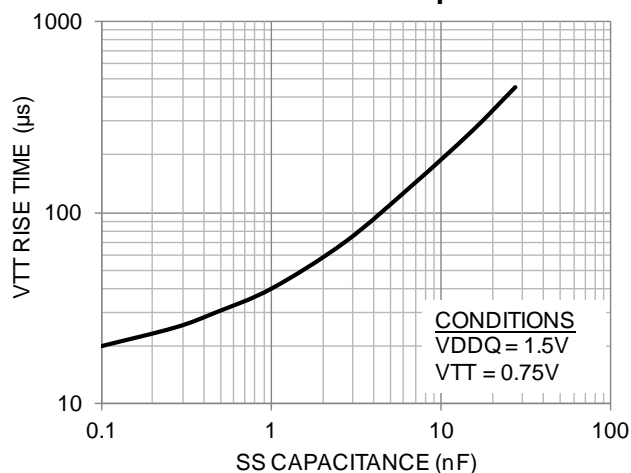

Typical Performance Characteristics

Output Ripple at 1A Load

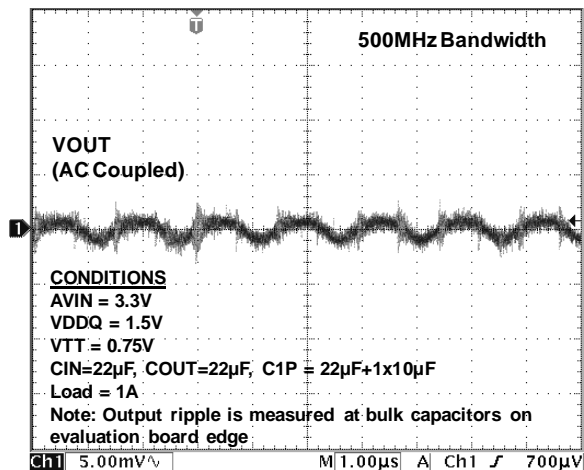

Output Ripple at 2A Load

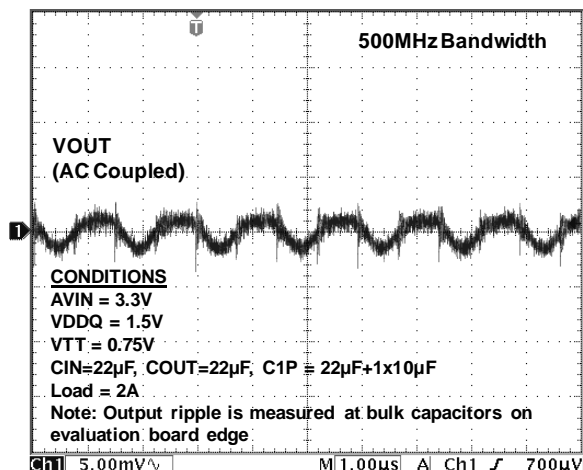

Switching Waveform at No Load

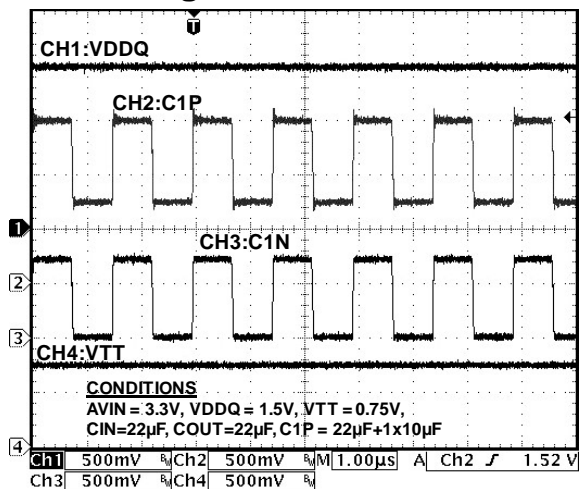

Switching Waveform at 500mA

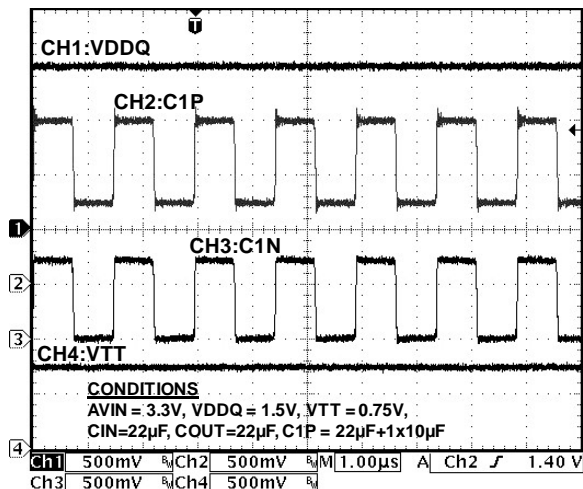

Switching Waveform at 1A

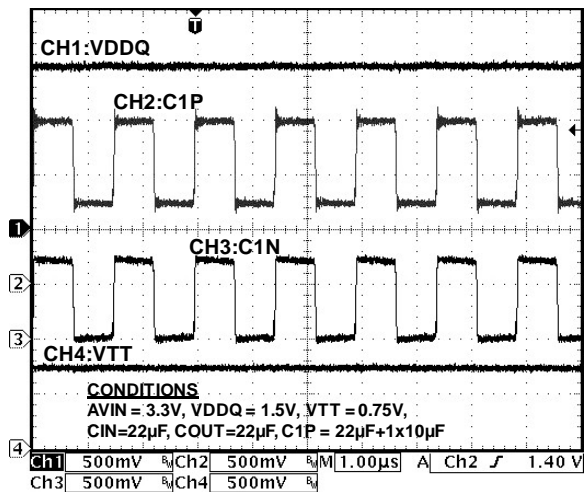

Switching Waveform at 2A

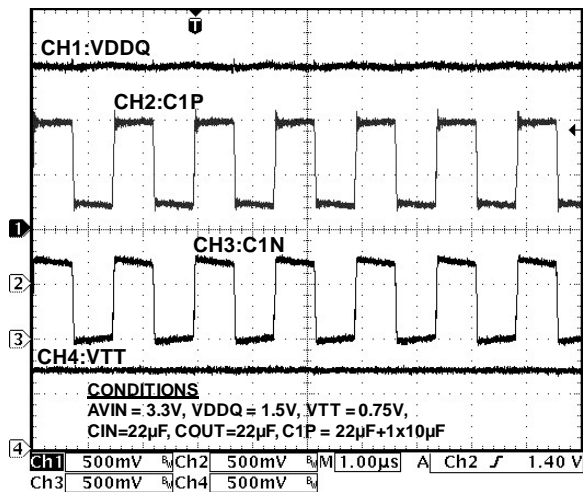

Typical Performance Characteristics (Continued)

Load Transient from 0 to 500mA

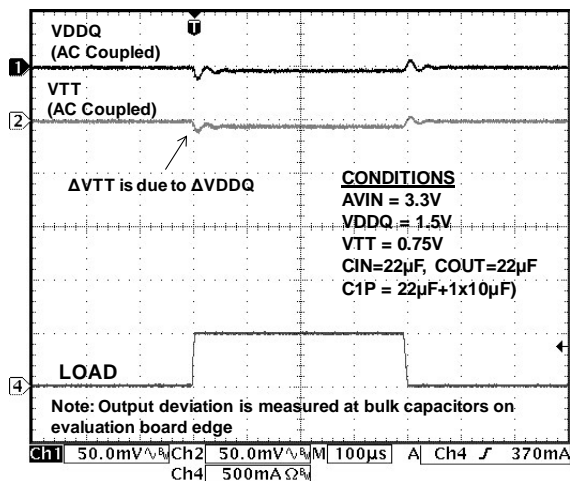

Load Transient from 0 to 1A

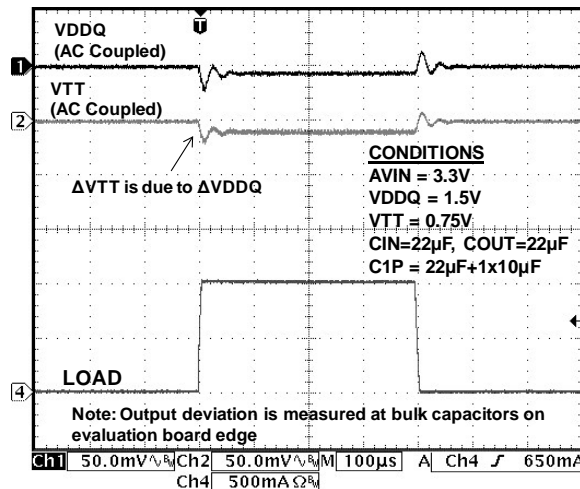

Load Transient from 0 to 1.5A

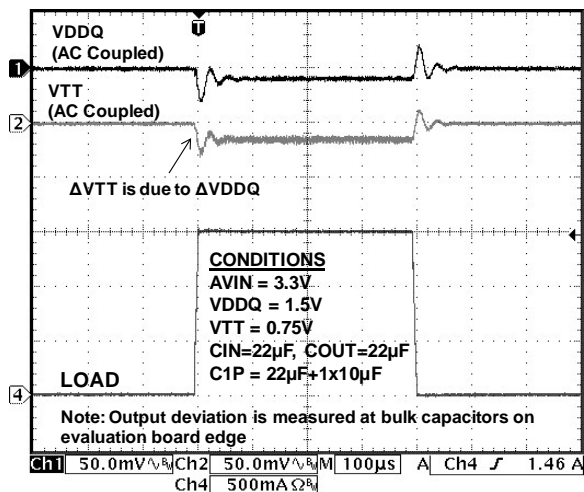

Load Transient from 0 to 2A

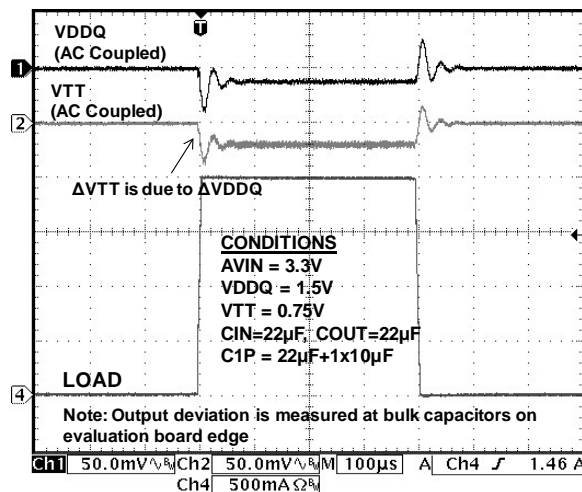

VDDQ to VTT Tracking with Line

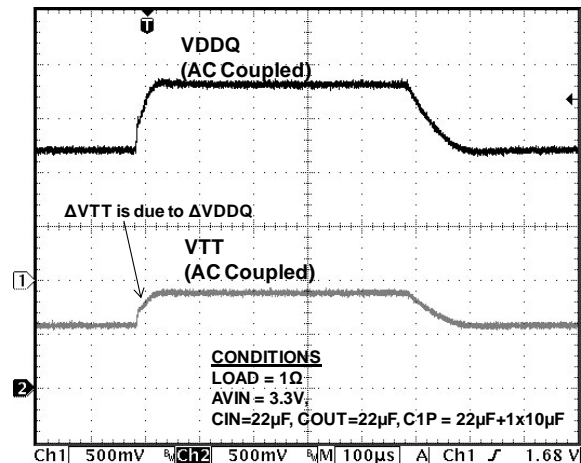

Startup with POK at No Load

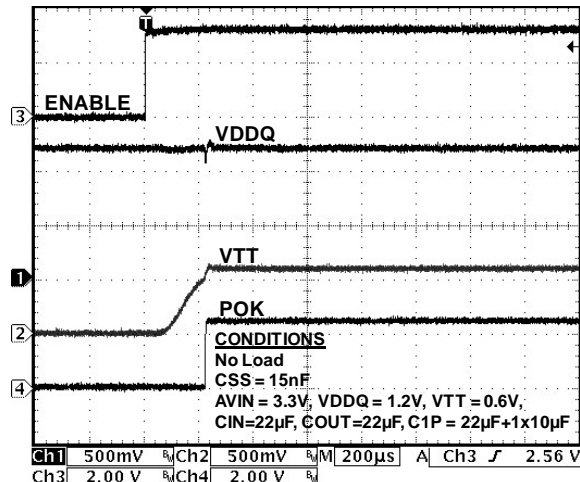

Typical Performance Characteristics (Continued)

Startup with POK at 2A

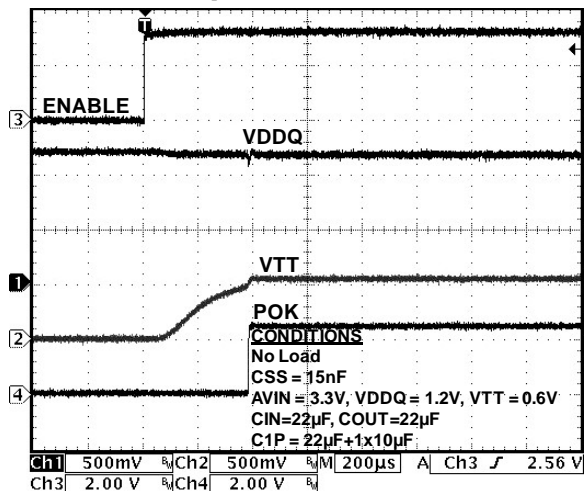

Parallel Operation Startup at 4A

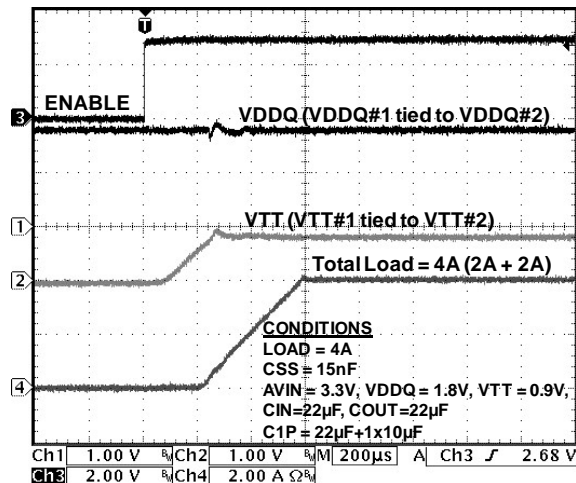

Parallel VDDQ Startup with POK

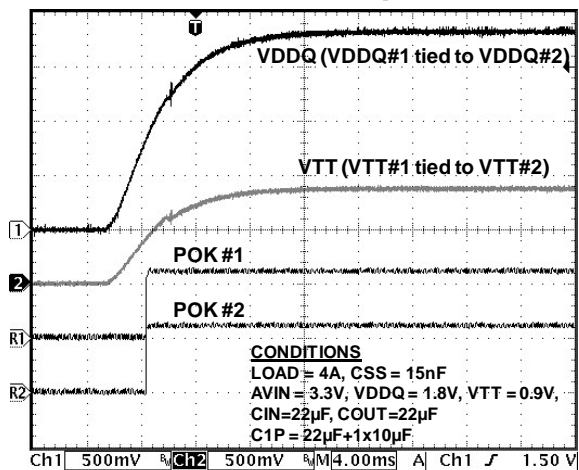

Parallel Operation at 4A

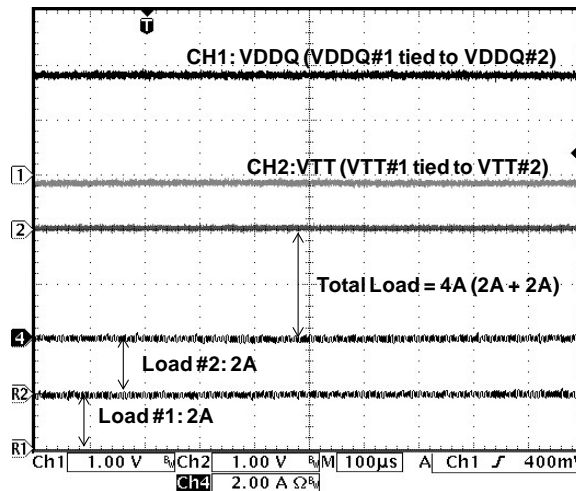

Parallel Operation Load Transient

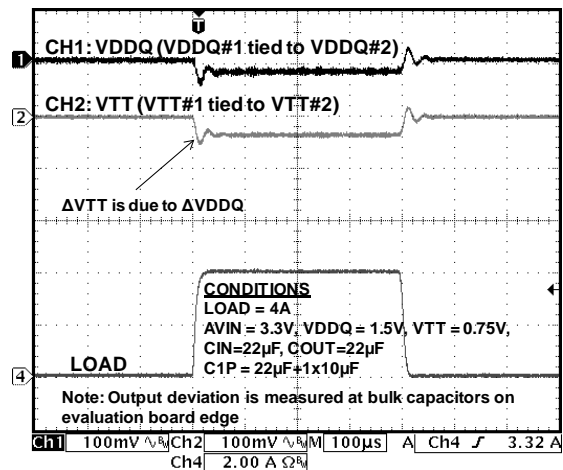

Functional Block Diagram

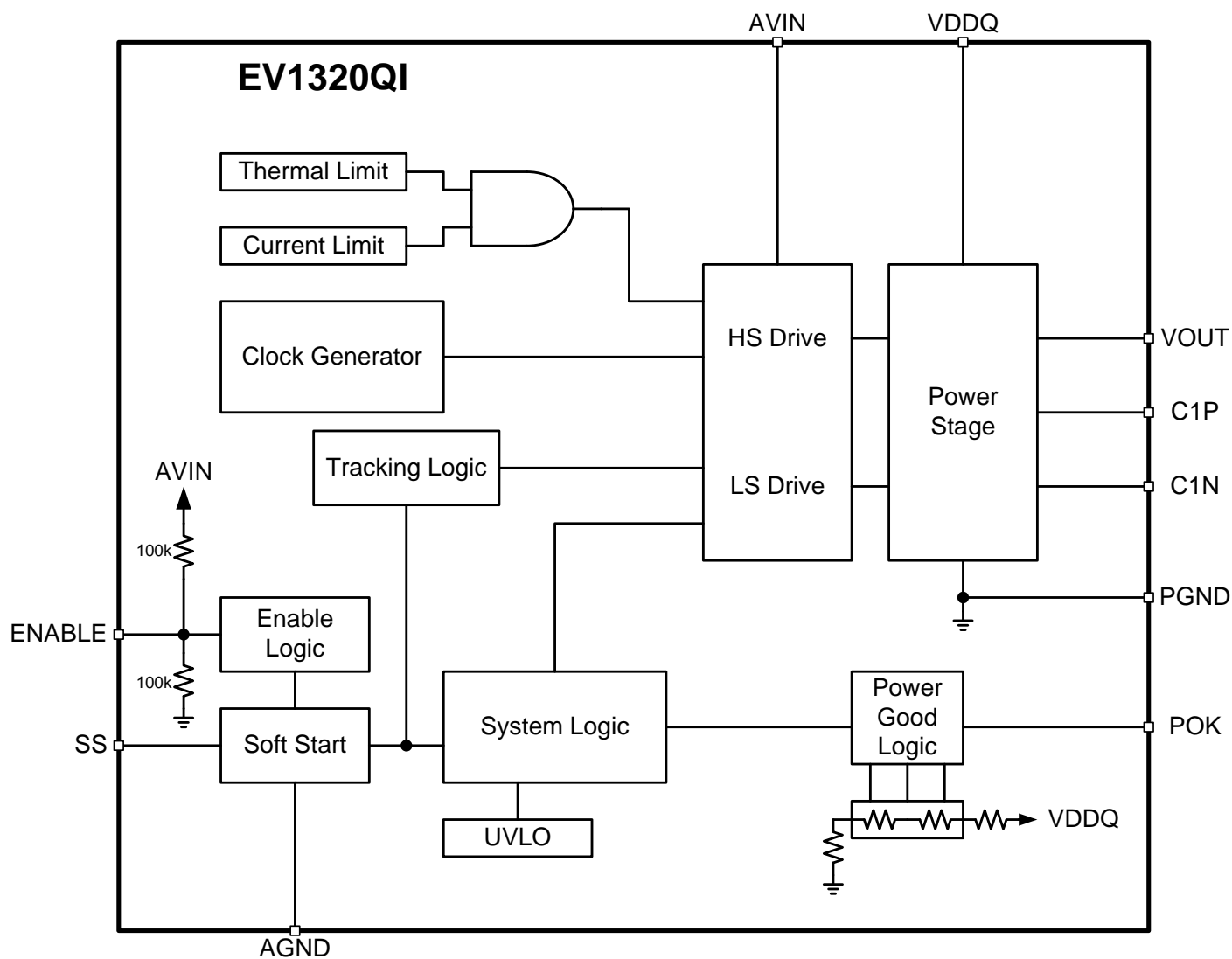

Figure 4: Functional Block Diagram

Functional Description

VDDQ/VTT Converter

The EV1320QI is designed to replace low efficiency linear regulators as well as expensive switch-mode DCDC memory terminations. The patented EV1320QI architecture provides efficiencies up to 96% with a solution footprint similar to that of a linear regulator.

VOUT (VTT) tracks $\frac{1}{2}$ VDDQ with ± 40 mV accuracy and is compliant with DDR2/3/QDR and low power DDR4 JEDEC memory termination requirements. The EV1320QI tracks VDDQ directly so there is no need for a separate reference voltage or resistor divider network.

If a VREF signal is needed for the VTT termination, it can be generated by an external VREF divider circuit from VDDQ, as shown in Figure 5. The R_{VREF} resistors divide the VDDQ voltage by 2 and can be used as the VREF signal. Choose high accuracy resistors for R_{VREF} . If more current is needed for VREF, the divider signal may be buffered by a voltage follower as shown in Figure 5. Be sure the R_{VREF} resistor values are negligible compared to the input impedance of the voltage follower to ensure VREF voltage accuracy.

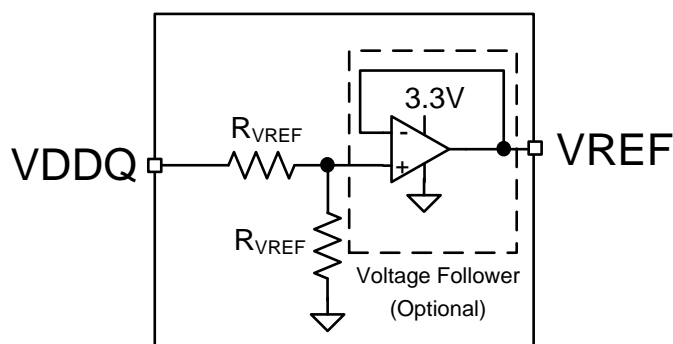

Figure 5. VREF Divider External Circuit

Soft-Start Operation

The EV1320QI has a programmable soft-start. The EV1320 can operate with AVIN on, ENABLE high, and VDDQ ramped up and down. If, however, VDDQ comes up first, and then the device is enabled, the soft-start capacitor limits the rise of the output (VTT). The output (VTT) ramp rate is determined by the value of the soft start (SS) capacitor, as shown in Table 1. The soft-start time begins when ENABLE crosses its threshold until VTT reaches final value.

Table 1. Typical Soft-Start Capacitance Time Table

(No Load)	
SS Capacitance (nF)	VTT Rise Time (μ s)
27	450
15	265
6.8	140
2.7	70
1	40
0.47	30
0.27	25
0.1	20

NOTE: If a fault condition occurs during normal operation the output is discharged through a 100Ω resistor for a period of 1.5mS and then a soft start cycle is initiated.

Enable Operation

The ENABLE pin provides a means to enable or disable operation of the part. When enable is pulled high the device will go through a soft start sequence. When enable is pulled low such as if the memory device enters S3 (suspend to RAM), the output will be discharged through a 100Ω resistor. Please note that if the equivalent load resistance is lower than 100Ω , the output will discharge faster. The ENABLE pin should not be left floating.

Power OK (POK)

The EV1320QI provides an open drain output to indicate if the output voltage stays within nominally $\pm 10\%$ of $VDDQ/2$. Within this range, the POK output is allowed to be pulled high. Outside this range, POK remains low. However, during transitions such as enable/disable and fault restart the POK output will not change state until the transition is complete for enhanced noise immunity.

The POK has 1mA sink capability for events where it needs to feed a device with standard CMOS inputs. When POK is pulled high, the pin leakage current is as low as 25μ A maximum over temperature. This allows a large pull up resistor such as $100k\Omega$ to be used for minimal current consumption in shutdown mode.

Over-Current Protection

The overload function is achieved by sensing the output voltage. An overload state is entered when the device is out of soft start and the output voltage drops below ~85% of $V_{DDQ}/2$. When an OCP condition is detected, the device is disabled, the output is discharged through a 100 resistor for a period of 1.5mS. After the 1.5mS discharge time has expired, a soft start is initiated as described in the soft start section. If an over current condition is again detected the device will repeat the discharge/soft start cycle in a hiccup manner as long as the over current condition persists.

Thermal Overload Protection

Thermal shutdown will disable operation when the Junction temperature exceeds approximately 150°C. Output will discharge through a 100 ohm resistor for 1.5mS. If the thermal fault condition is still present then the device will hiccup until temp falls by 25°C. Once the junction temperature drops by approximately 25°C, the converter will re-start with a normal soft-start.

Input Under-Voltage Lock-out

Internal circuits ensure that the converter will not start switching until the AVIN voltage is above the specified minimum voltage.

Application Information

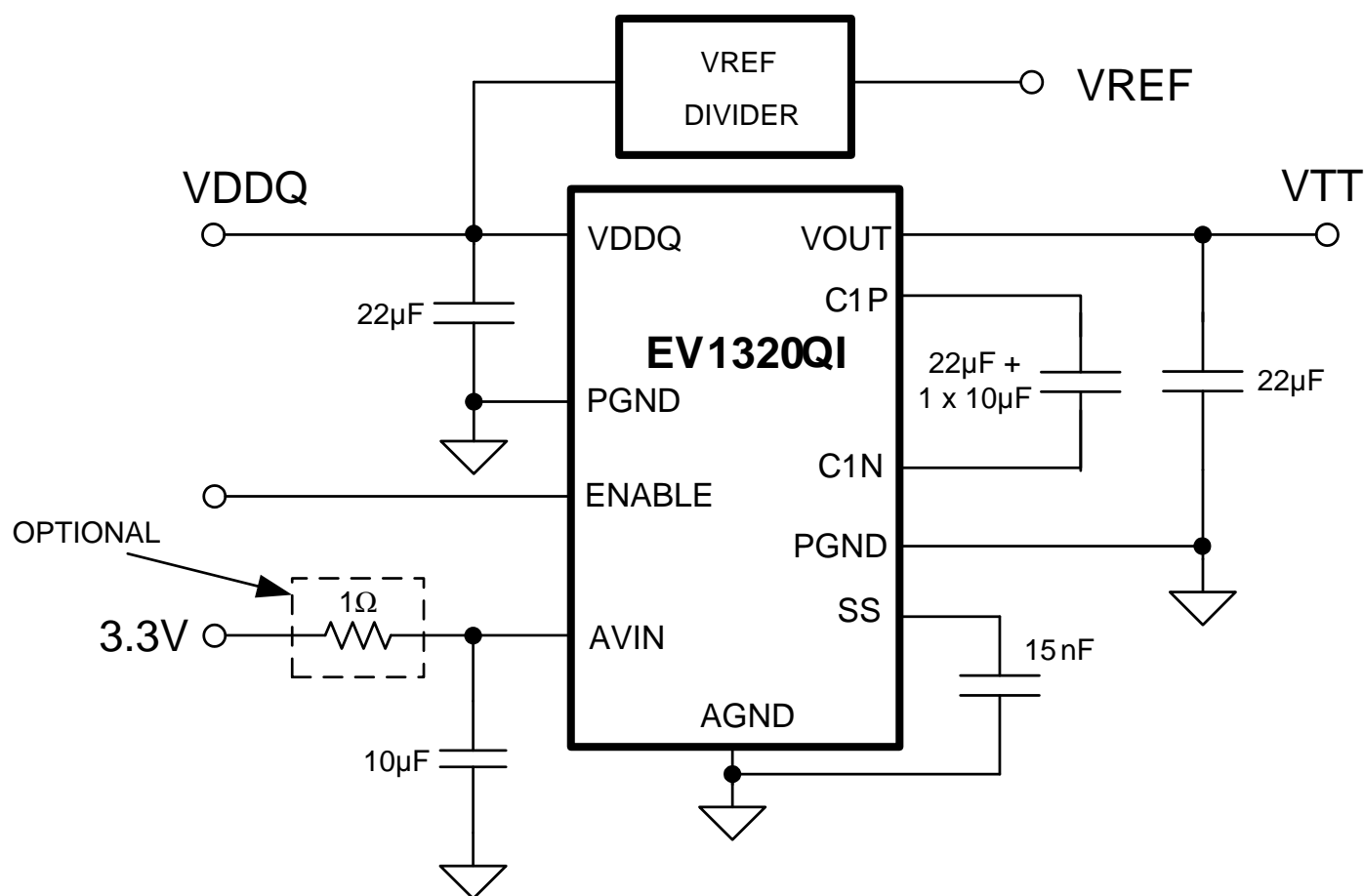

Figure 6. General Application Circuit for 2A Operation

General Application Circuit

Figure 6 shows a typical application circuit for the EV1320QI. The resistor before the AVIN capacitor is optional, but recommended if AVIN supply is noisy.

NOTE: The output filter capacitor section assumes that there is additional decoupling on the VTT island(s) of approximately 100µF per amp of VTT current. If this VTT decoupling is not present, additional bulk capacitance will be required on the EV1320QI output.

Soft-Start ramp rate is set by choice of the soft start capacitor (C_{SS}) as described in the soft start section.

Power Up Sequence

During power up, neither ENABLE nor VDDQ

should be asserted before AVIN. There are two common acceptable turn-on/off sequences for the device. ENABLE can be tied to AVIN and come up with it, and VDDQ can be ramped up and down as needed. In this case, the output will attempt to track VDDQ. Alternatively, VDDQ can be brought high after AVIN is asserted, and the device can be turned on and off by toggling the ENABLE pin. In this case, the output will ramp up as determined by the soft-start capacitor, and it will turn off as described in “Enable Operation” section.

Input Capacitors

A 22µF 4V X5R MLCC capacitor is required at the VDDQ input for 2A applications. A 10µF may be used for under 1A applications. The input capacitor must be placed at the position closest to the VDDQ pins of the EV1320QI. Either 0603 or 0805 case size is acceptable. The capacitors should be

connected between VDDQ pin and the PGND pin. Do not connect the capacitors to the AGND terminal. Do not use Y5V or equivalent dielectric capacitors. These capacitors lose substantial capacitance with bias, frequency, and temperature and are thus not appropriate for use in DCDC converter applications. Refer to the “Layout Recommendation” section for guidance on placement and PCB routing.

Table 1. Recommended Capacitor Configurations

Max I _{OUT}	C _{IN}	C _{OUT}	C _{FLY}
1A	10 μ F	10 μ F	22 μ F
2A	22 μ F	22 μ F	22 μ F + 10 μ F

Output Capacitors

A 22 μ F 4V X5R MLCC capacitor is required at the output for 2A applications. A 10 μ F may be used for under 1A applications. The output capacitor must be placed at the position closest to the VOUT pins of the EV1320QI. Either 0603 or 0805 case size is acceptable. The capacitors should be connected between VOUT pin and the PGND pin. Do not connect the capacitors to the AGND terminal. Do not use Y5V or equivalent dielectric capacitors. These capacitors lose substantial capacitance with bias, frequency, and temperature and are thus not appropriate for use in DCDC converter applications.

This capacitor recommendation assumes that there is additional bulk and decoupling capacitance at VTT DIMM leads and the VTT islands. Ensure that there is at least 100 μ F of bulk capacitance per amp of VTT current. If there is not sufficient bulk capacitance, add additional bulk capacitance to the output of the EV1320QI. Refer to the “Layout Recommendation” section for guidance on placement and PCB routing.

C_{1N} and C_{1P} Capacitors (C_{FLY})

A 22 μ F 4V X5R MLCC and a 10 μ F 4V X5R MLCC capacitors must be connected between the C_{1N} and C_{1P} pins for 2A applications. A 22 μ F may be used for under 1A applications. The C_{FLY} capacitor must be placed in the position closest to the C_{1N} and C_{1P} pins. The C_{1N} and C_{1P} pads should not be connected to any other plane or trace. Capacitor case size of 0805 or 0603 is acceptable. Do not use Y5V or equivalent dielectric capacitors. These capacitors lose substantial capacitance with bias, frequency, and temperature and are thus not appropriate for use in DCDC converter applications. Refer to the “Layout Recommendation” section for guidance on

placement and PCB routing.

Parallel Operation

The architecture of the EV1320QI lends itself to seamless parallel operation. Up to 4 devices can be paralleled to achieve a VTT current of up to 8A. Figure 7 shows an example circuit diagram for parallel operation of three EV1320QIs. The following guidelines must be followed for proper parallel operation.

1. The VDDQ inputs should be connected to a common VDDQ bus.
2. The VOUT connections should be connected to a common VTT bus.
3. Each EV1320QI device must have its own input and output capacitors connected close to the device as described in the input and output capacitor sections. The input and output capacitors should be connected to the local PGND pins on the respective EV1320QI devices.
4. The C_{1N}-C_{1P} capacitors should only be connected to their respective EV1320QI devices. They should not be connected to any common bus, VIN, VOUT, or any other signal or plane.
5. All AVIN connections should be tied to a common 3.3V supply rail. Each EV1320QI should have its own AVIN filter resistor and capacitor if required.
6. All ENABLE pins should be tied to a common enable signal.
7. All soft start pins should be tied together and a single soft start capacitor should be used. Each device should NOT have its own soft start capacitor.
8. All Analog ground (AGND) connections should be tied together. The single soft start capacitor should be connected to this common AGND.
9. All Power ground (PGND) connections should be tied together through a common PGND plane. However, each input and output capacitor complement should be connected to the local PGND pins on each individual EV1320QI device.
10. The devices should be placed such that the impedance in each path to the load is equivalent to ensure current balance.

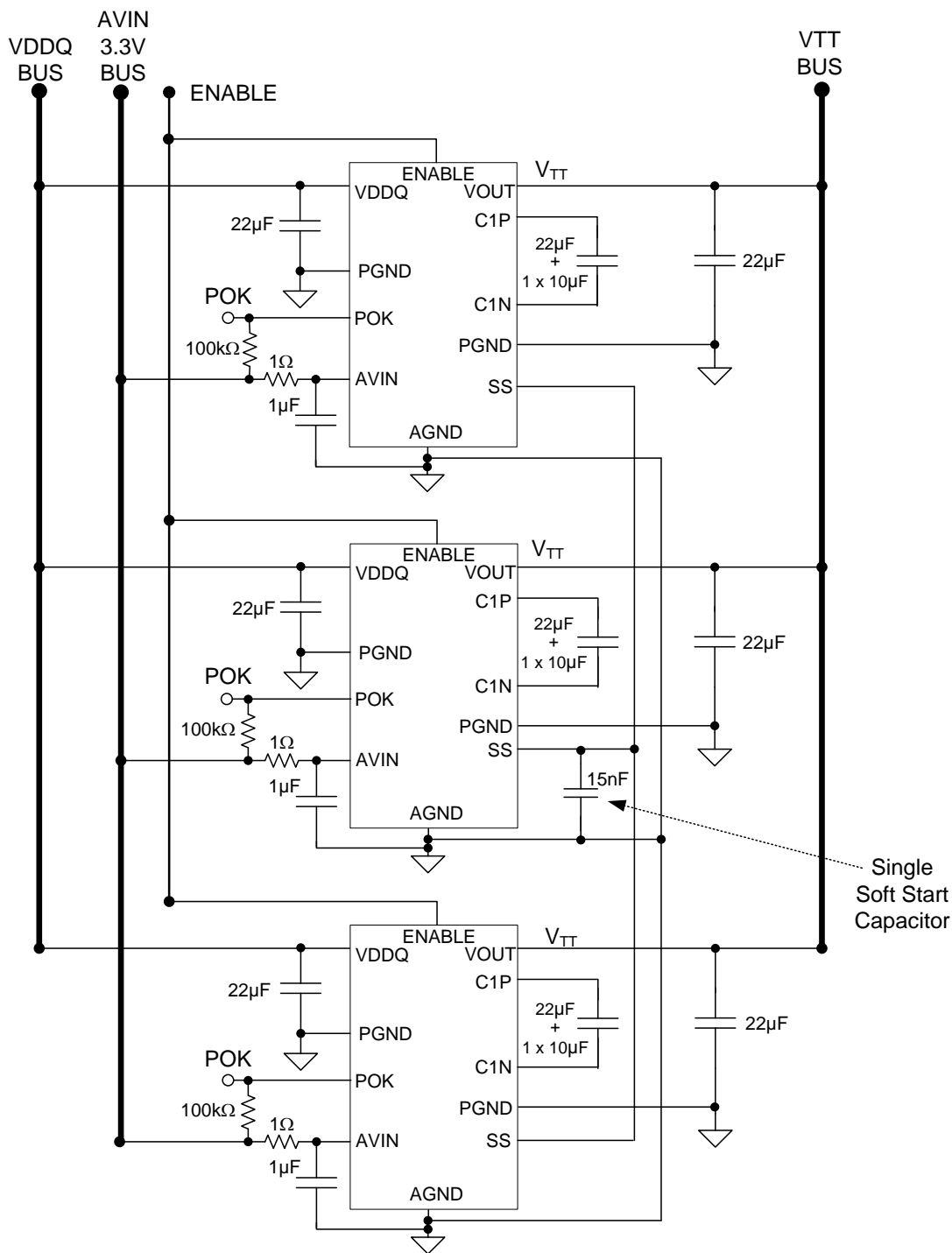

Figure 7. Parallel Operation with Three EV1320QI

Technical Support

Altera provides the mySupport website (www.altera.com/mysupport), which provides

technical support for the Power products and allows you to view and submit service requests.

Thermal Considerations

Thermal considerations are important physical limitations that cannot be avoided in the real world. Whenever there are power losses in a system, the heat that is generated by the power dissipation needs to be accounted for.

The Altera Enpirion EV1320QI VDDQ/VTT Converter is packaged in a 3x3x0.55mm 16-pin QFN package. The recommended maximum junction temperature for continuous operation is 125°C. Continuous operation above 125°C may reduce long-term reliability. The device has a thermal overload protection circuit designed to turn off the device at an approximate junction temperature value of 150°C.

The EV1320QI is guaranteed to support the full 2A output current up to 85°C ambient temperature. The following example and calculations illustrate the thermal performance of the EV1320QI.

Example:

$$V_{DDQ} = 1.2V$$

$$V_{TT} = 0.6V$$

$$I_{OUT} = 2A$$

First calculate the output power.

$$P_{OUT} = V_{TT} * I_{OUT} = 0.6V * 2A = 1.2W$$

Next, determine the input power based on the efficiency (η) shown in Figure 8.

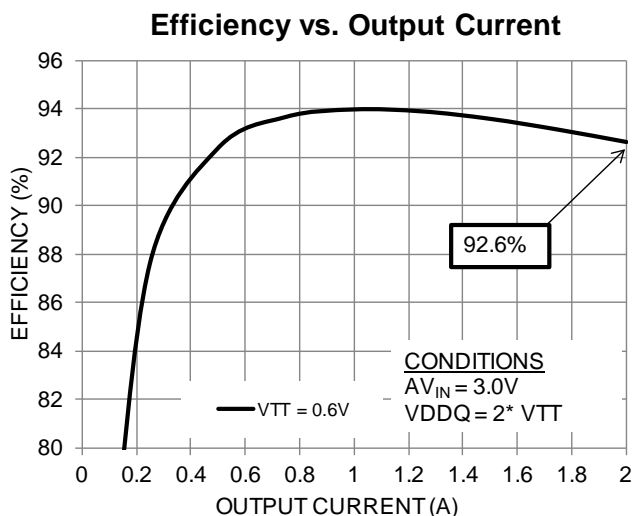

Figure 8: Efficiency vs. Output Current

For $V_{DDQ} = 1.2V$, $V_{TT} = 0.6V$ at 2A, $\eta \approx 92.6\%$

$$\eta = P_{OUT} / P_{IN} = 92.6\% = 0.926$$

$$P_{IN} = P_{OUT} / \eta$$

$$P_{IN} \approx 1.2W / 0.926 \approx 1.2959W$$

The power dissipation (P_D) is the power loss in the system and can be calculated by subtracting the output power from the input power.

$$P_D = P_{IN} - P_{OUT}$$

$$\approx 1.2959W - 1.2W \approx 0.0959W$$

With the power dissipation known, the temperature rise in the device may be estimated based on the theta JA value (θ_{JA}). The θ_{JA} parameter estimates how much the temperature will rise in the device for every watt of power dissipation. The EV1320QI has a θ_{JA} value of 50 °C/W without airflow.

Determine the change in temperature (ΔT) based on P_D and θ_{JA} .

$$\Delta T = P_D * \theta_{JA}$$

$$\Delta T \approx 0.0959W * 50°C/W = 4.795°C \approx 4.8°C$$

The junction temperature (T_J) of the device is approximately the ambient temperature (T_A) plus the change in temperature. We assume the initial ambient temperature to be 25°C.

$$T_J = T_A + \Delta T$$

$$T_J \approx 25°C + 4.8°C \approx 29.8°C$$

With 0.0959W dissipated into the device, the T_J will be 29.8°C.

The maximum operating junction temperature (T_{JMAX}) of the device is 125°C, so the device can operate at a higher ambient temperature. The maximum ambient temperature (T_{AMAX}) allowed can be calculated.

$$T_{AMAX} = T_{JMAX} - P_D * \theta_{JA}$$

$$\approx 125°C - 4.8°C \approx 120.2°C$$

The ambient temperature can actually rise by another 95.2°C, bringing it to 120.2°C before the device will reach T_{JMAX} . This indicates that the EV1320QI can support the full 2A output current range up to approximately 120.2°C ambient temperature given the input and output voltage conditions. This allows the EV1320QI to guarantee full 2A output current capability at 85°C with room for margin. Note that the efficiency will be slightly lower at higher temperatures and these calculations are estimates.

Layout Recommendation

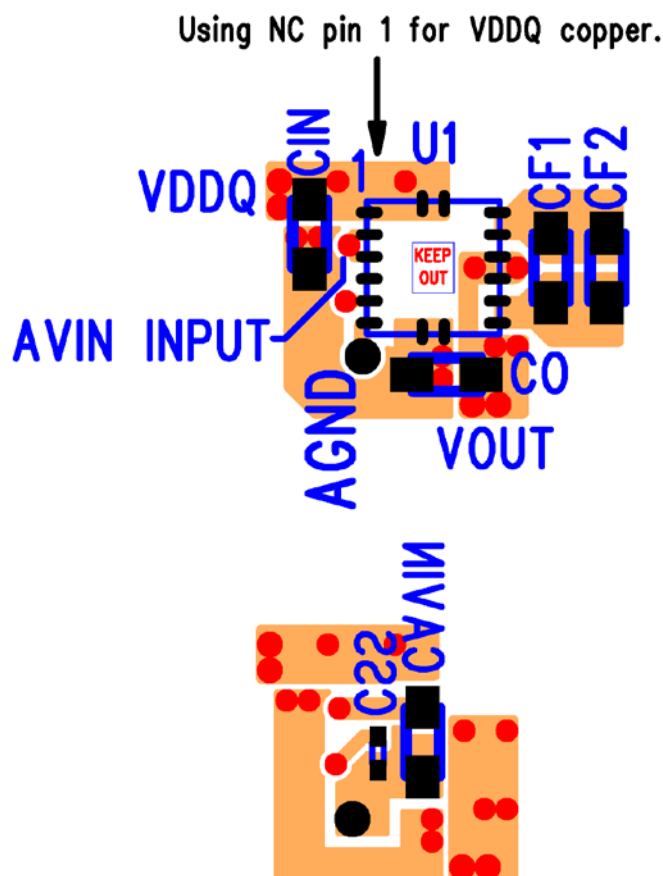

Figure 9: Typical Top Side and Bottom Side Layout Recommendation (Top View)

Figure 9 shows the critical components along with top and bottom traces of a recommended minimum footprint EV1320QI layout with ENABLE tied to VDDQ. Alternate enabling configurations, and the POK pin would have to be connected and routed according to the specific customer application. Please see the Gerber files at www.altera.com/enpirion for exact dimensions and the internal layers.

Recommendation 1: Input and output filter capacitors should be placed on the same side of the PCB, and as close to the EV1320QI package as possible. They should be connected to the device with very short and wide traces. Do not use thermal reliefs or spokes when connecting the capacitor pads to the respective nodes. The +V and GND traces between the capacitors and the EV1320QI should be as close to each other as

possible so that the gap between the two nodes is minimized, even under the capacitors.

Recommendation 2: The C1N-C1P capacitors should be placed as close to the C1N-C1P pins as possible. Use large copper planes to minimize resistance and inductance. The C1P and C1N traces between the capacitors and the EV1320QI should be as close to each other as possible so that the gap between the two nodes is minimized, even under the capacitors.

Recommendation 3: The system ground plane should be the first layer immediately below the surface layer (layer 2). This ground plane should be continuous and un-interrupted below the converter and the input/output capacitors.

Recommendation 4: The VDDQ and VOUT copper are paralleled on layers 3 and 4 in order to minimize overall series resistance. Please see Gerber files.

Recommendation 5: AVIN is the power supply for the internal control circuits. It should be connected to the 3.3V bus at a quiet point. A 10 μ F bypass capacitor (shown on the backside in Figure 9) is needed on the AVIN node. If the AVIN supply is noisy, an optional 1 Ω resistor is recommended in series with AVIN. See Figure 6.

Recommendation 6: The AGND pin does not get connected to PGND on layer 1. It connects to PGND on layer 2 ground plane. This provides some noise isolation between AGND and the noisy PGND trace on layer 1.

Recommendation 7: The soft-start capacitor CSS and the AVIN capacitor CAVIM are placed on the back side in Figure 9 so that the input PGND trace is not compromised.

Recommendation 8: If POK needs to be used, place a via to the left of pin 4, and route the POK trace on layer 3 to the POK resistor. Place the POK resistor to AVIN such that any modifications to the traces and placements in this recommended layout are minimized.

Recommendation 9: Follow all the layout recommendations as close as possible to optimize performance. Altera provides schematic and layout reviews for all customer designs. Please contact www.altera.com/mysupport for Power Applications support.

Recommended PCB Footprint

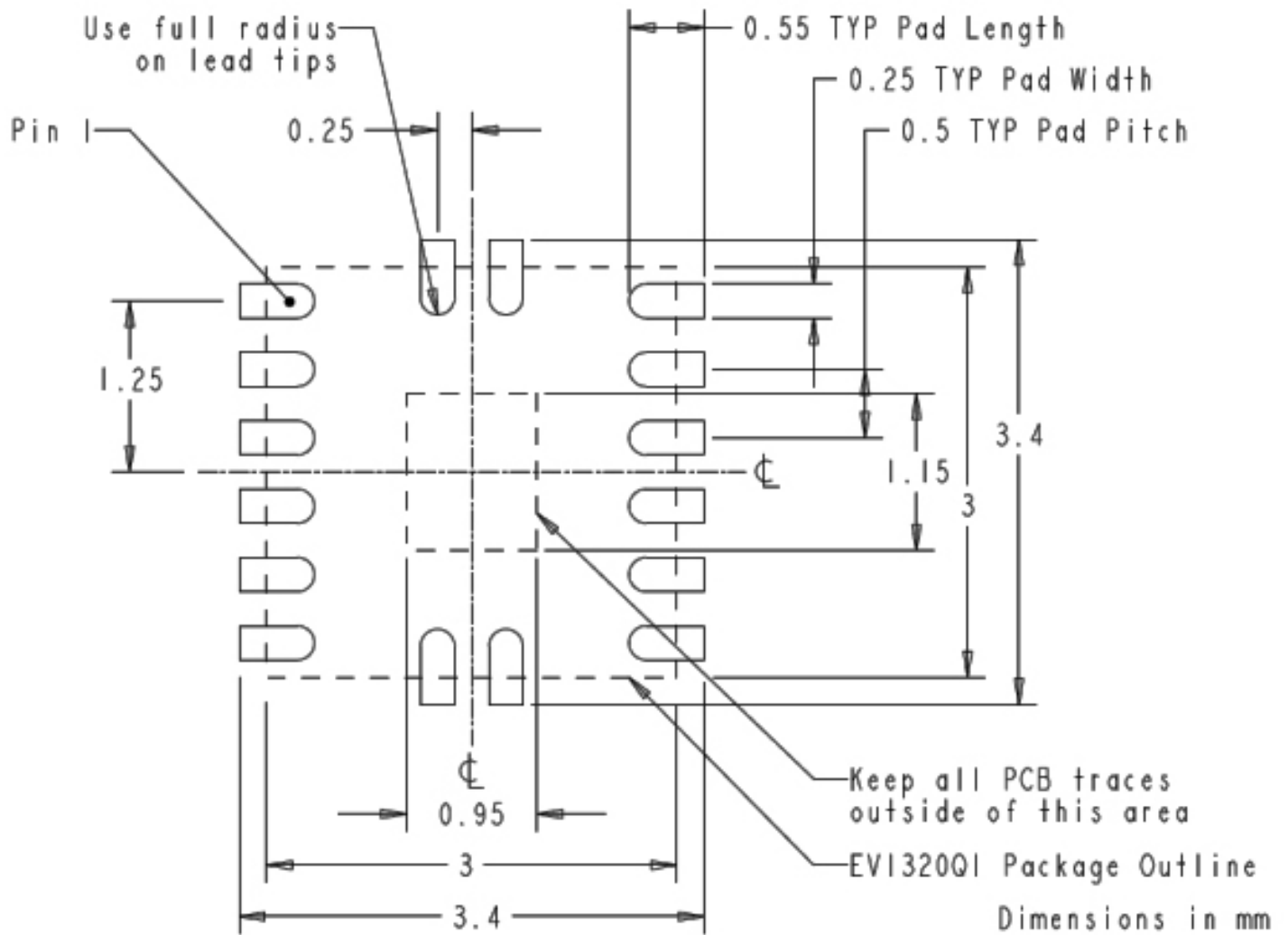

Figure 10: EV1320QI PCB Footprint (Top View)

Package and Mechanical

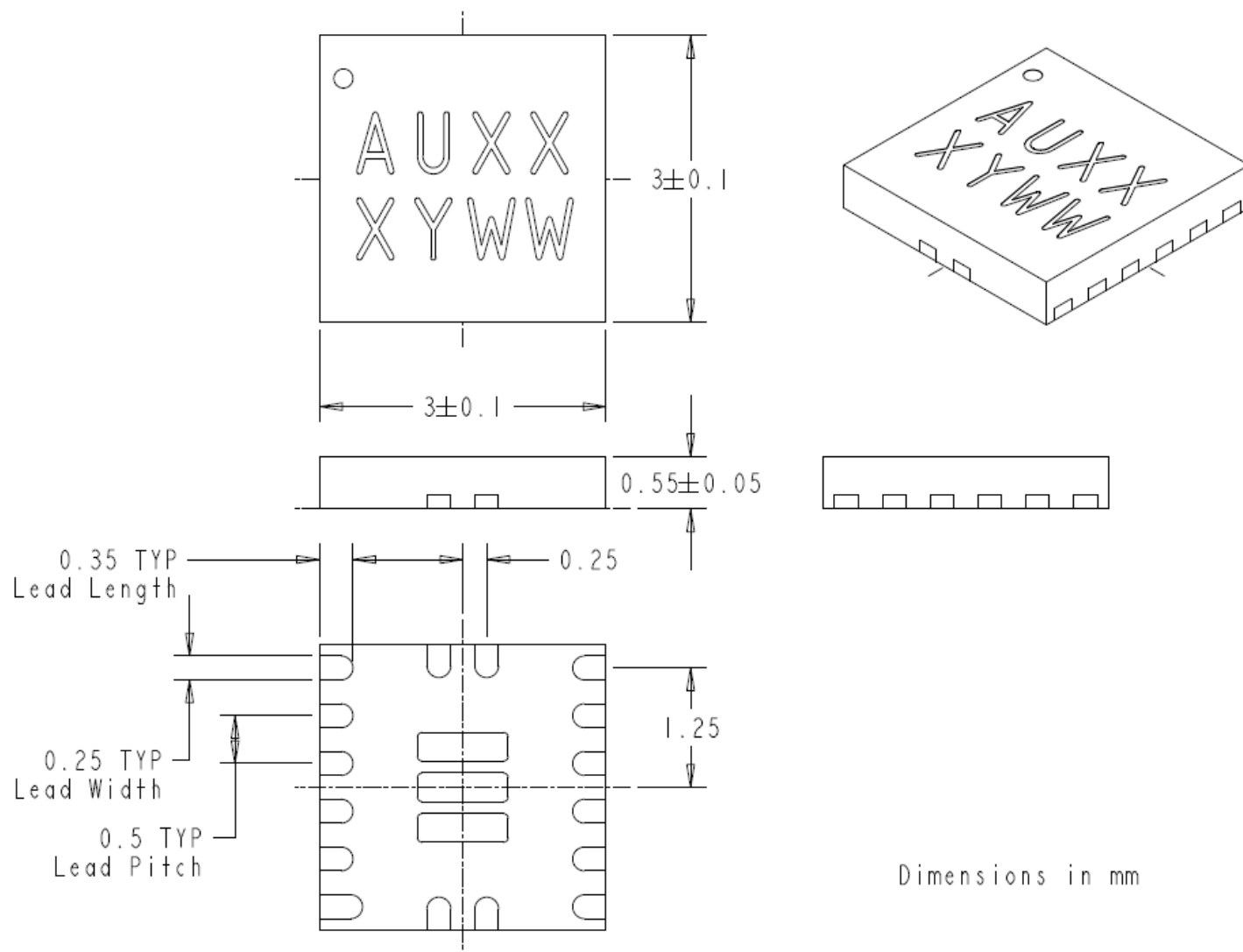

Figure 11: EV1320QI Package Dimensions (Bottom View)

Contact Information

Altera Corporation
 101 Innovation Drive
 San Jose, CA 95134
 Phone: 408-544-7000
www.altera.com

© 2013 Altera Corporation—Confidential. All rights reserved. ALTERA, ARRIA, CYCLONE, ENPIRION, HARDCOPY, MAX, MEGACORE, NIOS, QUARTUS and STRATIX words and logos are trademarks of Altera Corporation and registered in the U.S. Patent and Trademark Office and in other countries. All other words and logos identified as trademarks or service marks are the property of their respective holders as described at www.altera.com/common/legal.html. Altera warrants performance of its semiconductor products to current specifications in accordance with Altera's standard warranty, but reserves the right to make changes to any products and services at any time without notice. Altera assumes no responsibility or liability arising out of the application or use of any information, product, or service described herein except as expressly agreed to in writing by Altera. Altera customers are advised to obtain the latest version of device specifications before relying on any published information and before placing orders for products or services.