

Protection for Ethernet lines

Features

- Differential and common mode protection
- Telcordia GR1089 Intrabuilding: 150 A, 2/10 μ s
- ITU-T K20/21: 40 A, 5/310 μ s
- Low capacitance: 13 pF max at 0 V
- UL94 V0 approved resin
- SO-8 package is JEDEC registered

Benefits

- Trisil™ technology is not subject to ageing and provides a fail safe mode in short circuit for a better protection.
- This series is used to help equipment to meet main standards such as UL61950, IEC 950 / CSA C22.2 and UL1459.

Complies with the following standards

- IEC 61000-4-2: Level 4
 - 15 kV (air discharge)
 - 8 kV (contact discharge)
- MIL STD 883E-Method 3015-7: class3:
 - 25 kV (Human body model)
- Telcordia GR-1089 Core: 100 A, 2/10 μ s
- ITU-T K20/21: 37.5 A, 5/310 μ s
- IEC 61000-4-5: 4 kV, 42 Ω , 96 A, 8/20 μ s
- IEC 61000-4-4 EFT : 40A (5/50ns)

Applications

This series can meet subscriber and central office requirements.

- Protection against telecommunications surge standards on:
 - 10/100 Mbps Ethernet
 - T1 / E1 line cards

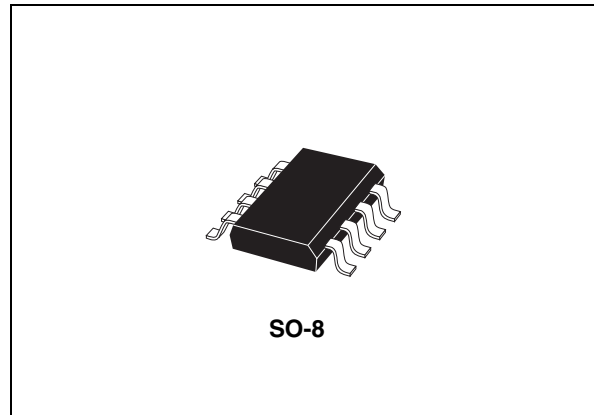
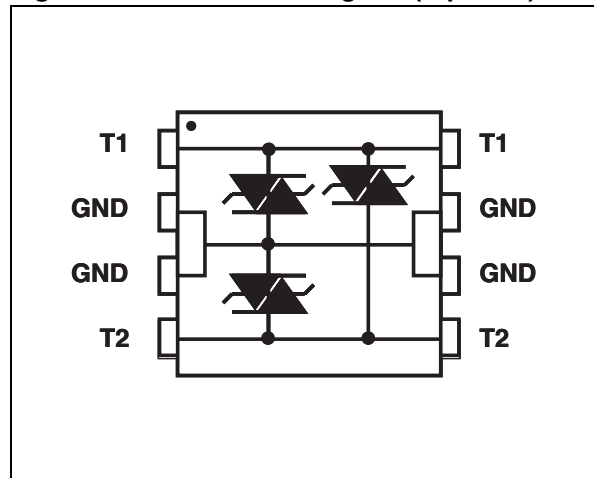

Figure 1. Schematic diagram (top view)



Description

The ETP01 series is a low capacitance transient surge arrester designed for protection of high debit rate communication network. Planar technology used combines a high surge capability to comply with Telcordia GR1089 Intrabuilding and ITU-T K20/21, and low capacitance to avoid distortion of high speed signals such as Ethernet.

TM: Trisil is a trademark of STMicroelectronics

1 Characteristics

Table 1. Absolute ratings ($T_{amb} = 25\text{ °C}$)

Symbol	Parameter		Value	Unit
I_{pp}	Peak pulse current ⁽¹⁾	5/310 μs	40	A
		8/20 μs	100	A
		2/10 μs	150	A
I_{TSM}	Non repetitive surge peak on state current	t = 20 ms	8	A
T_{stg} T_j	Storage temperature range Operating junction temperature range		-55 to 150 -40 to 150	$^{\circ}\text{C}$
T_L	Maximum temperature for soldering during 10 s		260	$^{\circ}\text{C}$

1. Surge capability tested according to ITU-T K20/21 and Telcordia GR1089 Intrabuilding connections (Metallic and Longitudinal tests).

Table 2. Electrical characteristics ($T_{amb} = 25\text{ °C}$)

Order code	$I_{RM} @ V_{RM}$		$I_{RM} @ V_{RM}$		V_{bo}	I_H	C	C
	μA typ.	V	μA max.	V	V max.	mA min.	pF max. ⁽¹⁾	pF max. ⁽²⁾
ETP01-1621	0.01	3.3	1	16	25	30	16	13
ETP01-2821	0.01	3.3	1	28	36	30	16	13

1. Test conditions: Capacitance between I/O and GND, $V_R = 0\text{ V}$ bias, $V_{RMS} = 1\text{ V}$, $F = 1\text{ MHz}$
 2. Test conditions: Capacitance between I/O and I/O, $V_R = 0\text{ V}$ bias, $V_{RMS} = 1\text{ V}$, $F = 1\text{ MHz}$

Figure 2. Non repetitive surge peak on-state current versus overload duration

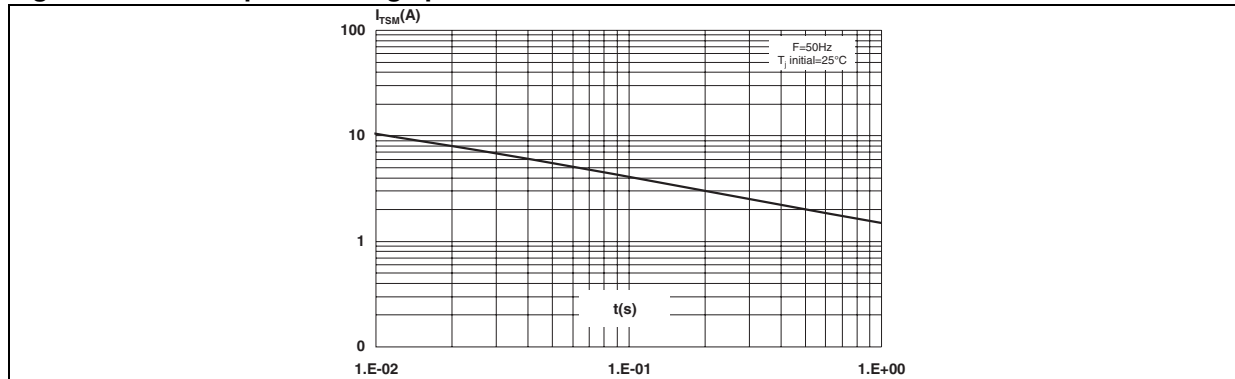

Figure 3. Junction capacitance versus reverse voltage applied for ETP01-1621 (typical values)

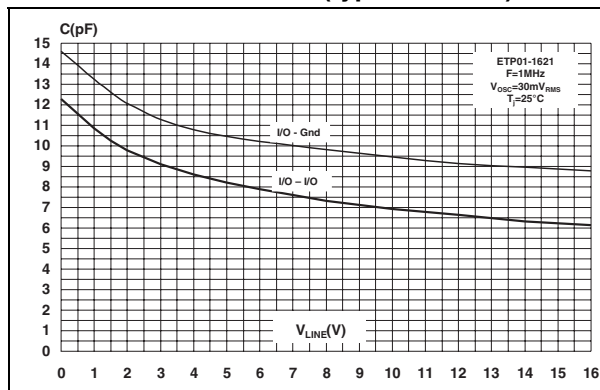
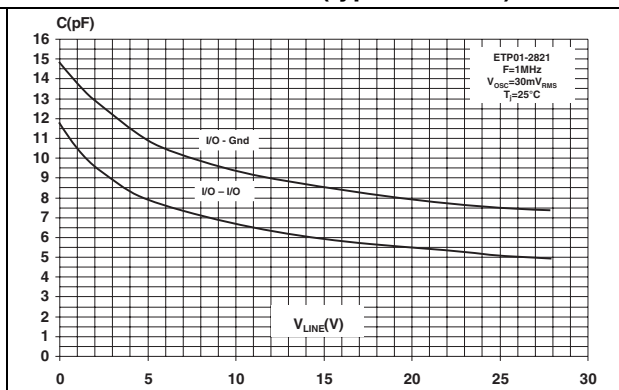

Figure 4. Junction capacitance versus reverse voltage applied for ETP01-2821 (typical values)



2 Application information

Figure 5. Application schematic for Ethernet 10/100 Mbps

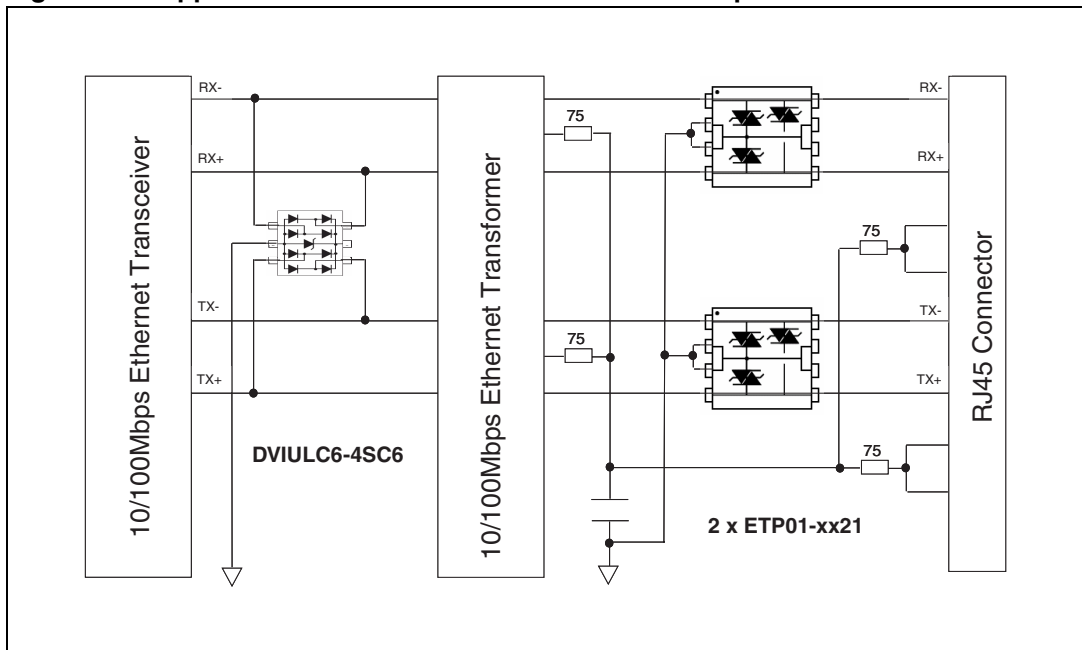
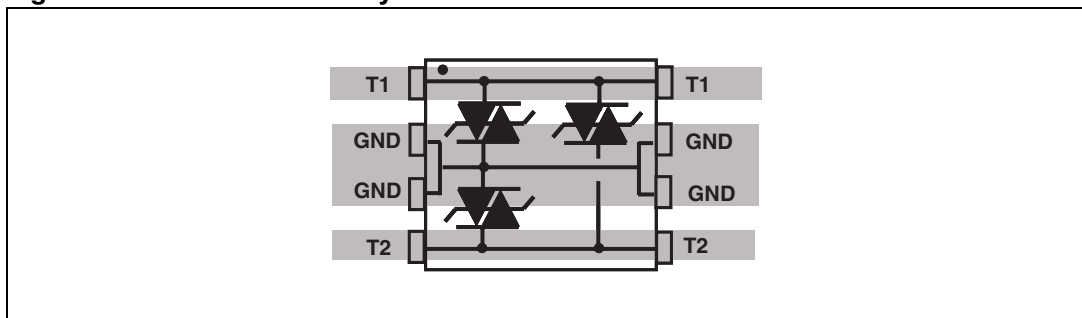

Figure 6. Recommended layout



3 Package information

- Epoxy meets UL94, V0
- Lead-free package

In order to meet environmental requirements, ST offers these devices in different grades of ECOPACK® packages, depending on their level of environmental compliance. ECOPACK® specifications, grade definitions and product status are available at: www.st.com. ECOPACK® is an ST trademark.

Table 3. SO-8 dimensions

Ref.	Dimensions					
	Millimeters			Inches		
	Min.	Typ.	Max.	Min.	Typ.	Max.
A			1.75			0.069
A1	0.1		0.25	0.004		0.010
A2	1.25			0.049		
b	0.28		0.48	0.011		0.019
C	0.17		0.23	0.007		0.009
D	4.80	4.90	5.00	0.189	0.193	0.197
E	5.80	6.00	6.20	0.228	0.236	0.244
E1	3.80	3.90	4.00	0.150	0.154	0.157
e		1.27			0.050	
h	0.25		0.50	0.010		0.020
L	0.40		1.27	0.016		0.050
L1		1.04			0.041	
k	0°		8°	0°		8°
ppp			0.10			0.004

Figure 7. Footprint dimensions in mm (inches)

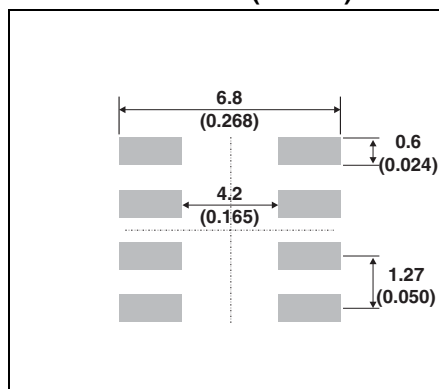
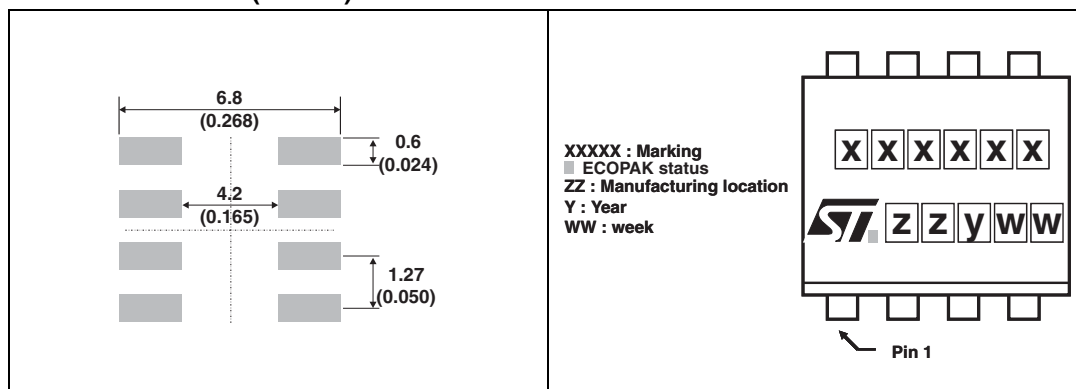

Figure 8. Marking



4 Ordering information

Table 4. Ordering information

Order code	Marking	Weight	Base qty	Delivery mode
ETP01-1621RL	ETP162	0.08 g	2500	Tape and reel
ETP01-2821RL	ETP282	0.08 g	2500	Tape and reel

5 Revision history

Table 5. Document revision history

Date	Revision	Changes
04-Mar-2008	1	Initial release.
24-Sep-2009	2	Updated order code in Table 4 and surge values.
19-Feb-2010	3	Updated Figure 1 caption to indicate top view. Updated graphic in Table 3 to facilitate pin 1 identification. Updated Figure 8 to show ECOPACK status marking.
10-May-2011	4	Updated: Applications on page 1 .

Please Read Carefully:

Information in this document is provided solely in connection with ST products. STMicroelectronics NV and its subsidiaries ("ST") reserve the right to make changes, corrections, modifications or improvements, to this document, and the products and services described herein at any time, without notice.

All ST products are sold pursuant to ST's terms and conditions of sale.

Purchasers are solely responsible for the choice, selection and use of the ST products and services described herein, and ST assumes no liability whatsoever relating to the choice, selection or use of the ST products and services described herein.

No license, express or implied, by estoppel or otherwise, to any intellectual property rights is granted under this document. If any part of this document refers to any third party products or services it shall not be deemed a license grant by ST for the use of such third party products or services, or any intellectual property contained therein or considered as a warranty covering the use in any manner whatsoever of such third party products or services or any intellectual property contained therein.

UNLESS OTHERWISE SET FORTH IN ST'S TERMS AND CONDITIONS OF SALE ST DISCLAIMS ANY EXPRESS OR IMPLIED WARRANTY WITH RESPECT TO THE USE AND/OR SALE OF ST PRODUCTS INCLUDING WITHOUT LIMITATION IMPLIED WARRANTIES OF MERCHANTABILITY, FITNESS FOR A PARTICULAR PURPOSE (AND THEIR EQUIVALENTS UNDER THE LAWS OF ANY JURISDICTION), OR INFRINGEMENT OF ANY PATENT, COPYRIGHT OR OTHER INTELLECTUAL PROPERTY RIGHT.

UNLESS EXPRESSLY APPROVED IN WRITING BY AN AUTHORIZED ST REPRESENTATIVE, ST PRODUCTS ARE NOT RECOMMENDED, AUTHORIZED OR WARRANTED FOR USE IN MILITARY, AIR CRAFT, SPACE, LIFE SAVING, OR LIFE SUSTAINING APPLICATIONS, NOR IN PRODUCTS OR SYSTEMS WHERE FAILURE OR MALFUNCTION MAY RESULT IN PERSONAL INJURY, DEATH, OR SEVERE PROPERTY OR ENVIRONMENTAL DAMAGE. ST PRODUCTS WHICH ARE NOT SPECIFIED AS "AUTOMOTIVE GRADE" MAY ONLY BE USED IN AUTOMOTIVE APPLICATIONS AT USER'S OWN RISK.

Resale of ST products with provisions different from the statements and/or technical features set forth in this document shall immediately void any warranty granted by ST for the ST product or service described herein and shall not create or extend in any manner whatsoever, any liability of ST.

ST and the ST logo are trademarks or registered trademarks of ST in various countries.

Information in this document supersedes and replaces all information previously supplied.

The ST logo is a registered trademark of STMicroelectronics. All other names are the property of their respective owners.

© 2011 STMicroelectronics - All rights reserved

STMicroelectronics group of companies

Australia - Belgium - Brazil - Canada - China - Czech Republic - Finland - France - Germany - Hong Kong - India - Israel - Italy - Japan - Malaysia - Malta - Morocco - Philippines - Singapore - Spain - Sweden - Switzerland - United Kingdom - United States of America

www.st.com